

(19)
(12)

(KR)
(Y1)

(51) 。 Int. Cl. 7
H02G 9/08

(45)
(11)
(24)

2002 12 31
20 - 0299522
2002 12 16

(21) 20 - 2002 - 0028091
(22) 2002 09 18

(73) 1 167

(72) 3 528 102 303

(74)
:
가 :

(54)

(1) (2) ,

(1) (3) (3a) (2)

(2) U (4) (5) .

1

1 ,

2(a),(b),(c) .

- -

1 : , 2 : ,
 3 : , 3a : ,
 4 : U , 5 : ,
 6 : .

가

, L

| ,

가

, | 가

가

U 가

1

1) () , ()
 (1) (2) U (4) (3) (5) (3a) (2)

(3) U (1) (4)가 () (2) 가 ,
 (2) U (4) (6)가
 U (4) (3) (1) (2)

(57)

1.

(1) (2)
 (1) (2) U (4) (3) (3a) (2)
 (5)

2.

1 (6)가 , (2) U (4)

1

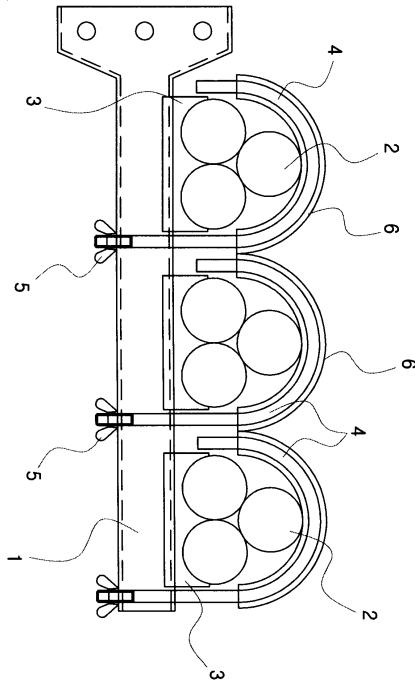

2

