

SIMEON ATHA.

IMPROVEMENT IN CARRIAGE HUBS.

109707

PATENTED NOV 29 1870

Fig. 1.

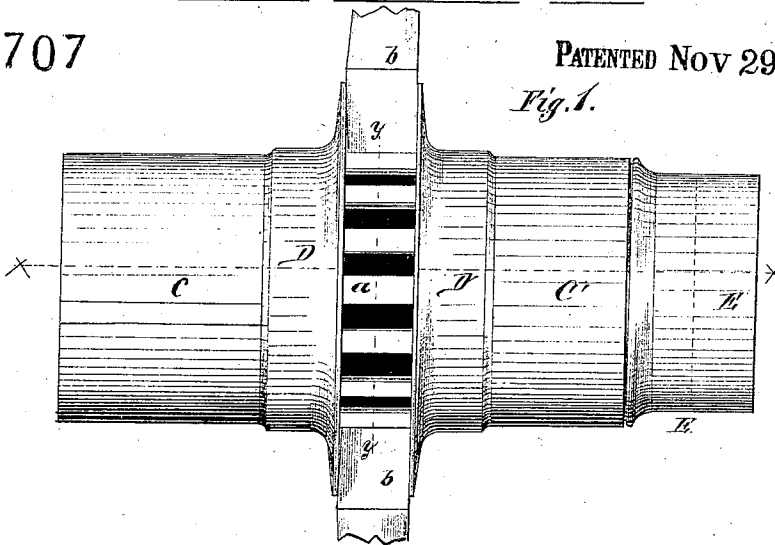

Fig. 2.

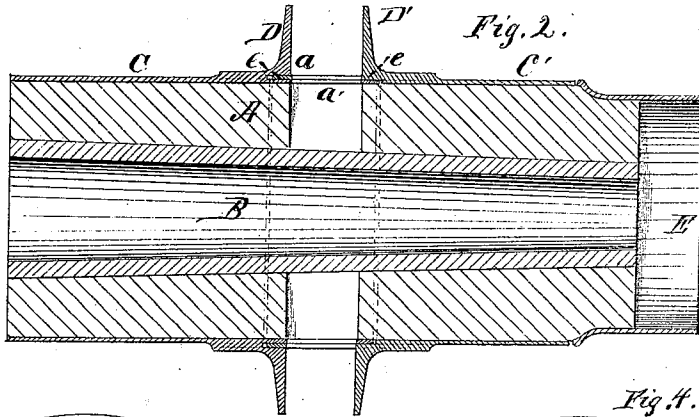

Fig. 3.

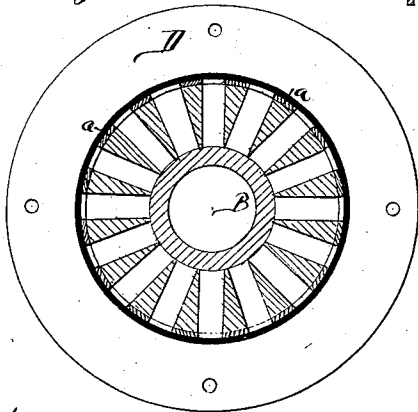
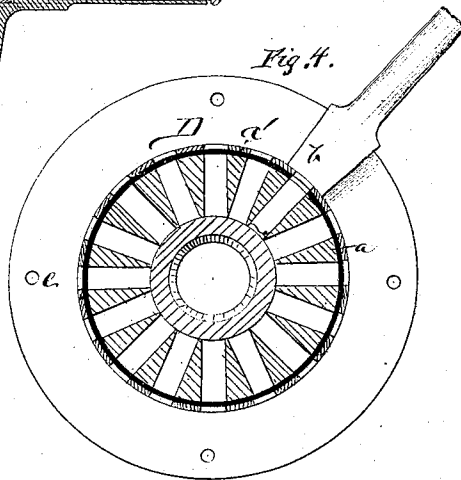

Fig. 4.



Witnesses:

W. Basilton Colman
John A. Dickerson

Inventor.

Simeon Atha
By Messrs. A. C. Klauker & Co.
his attorneys

United States Patent Office.

SIMEON ATHA, OF WEST LIBERTY, OHIO.

Letters Patent No. 109,707, dated November 29, 1870.

IMPROVEMENT IN CARRIAGE-WHEEL HUBS.

The Schedule referred to in these Letters Patent and making part of the same.

To all whom it may concern:

Be it known that I, SIMEON ATHA, of West Liberty, in the county of Logan, in the State of Ohio, have invented a certain new and useful Improvement in Carriage-Wheel Hubs; and I do hereby declare the following to be a full, clear, and exact description of the construction of the nature thereof, sufficient to enable others skilled in the art to which my invention appertains to make and use the same, reference being had to the accompanying drawing making part of this specification, in which—

Figure 1 is a view of my improved carriage-wheel hub, with a spoke or two inserted;

Figure 2 is a central longitudinal section, while

Figures 3 and 4 are inner-faced views of the metallic shells or boxes.

Like letters of reference indicate corresponding parts in each figure.

Nature and Object of this Invention.

This invention relates to that class of devices known as carriage-wheel hubs, and has for its object to improve upon that class of hubs wherein a metallic shell or band is driven or secured upon the ordinary mortised wooden hub, to receive the tenons of and support the spokes; and to this end,

My invention consists in the production of a carriage-wheel hub, in such a manner that the wooden hub or core is entirely covered with a metallic shell or band, whereby the tendency of the wooden hub or core splitting or chipping off is obviated.

Also, in forming such a metallic covering of two separate and independent metallic mortises and flanges, which support and brace the spokes in front and rear; and,

Finally, in the peculiar construction and combination of certain parts, all of which will hereinafter be more fully set forth.

In the drawing—

A may represent the mortised wooden hub or core;

B, the axle-box;

C C', the metallic shells or bands, with their mortised plates *a a'* and flanges D D'; while

E is an ordinary hub-band.

The wooden hub or core A may be of any desired form upon the outer surface, and provided with the usual mortises to receive the tenons of the spokes.

C C' are metallic shells or bands, of any configuration on their outer surfaces, made in such a manner as to cover, more or less, the entire surface of the mortised wooden hub or core A, so as to effectually guard against any splitting or chipping off of the said wooden portion upon its outer surface.

These metallic shells or bands C C' are each formed or provided with its own separate and independent

metallic plates *a a'*, which are mortised to correspond in shape to the mortises in the wooden hub or core A.

D D' are flanges which embrace or support the front and rear sides of the spokes, and are formed with or otherwise secured upon the metallic shells or bands C C' in such a manner that an opening, *e e*, is left part way between the inner edges of the said flanges and the metal shells or bands C C', so that the metallic plates *a a'* may slide or pass over each other, and their respective ends enter into said openings *e e*, their mortises coinciding with the mortises in the wooden hub or core.

By thus constructing the shells or bands with the metallic plate having mortises, and causing them to slide or pass over each, it is evident that when the spokes are inserted into the mortises the flanges D D' are drawn tight and close, and firmly brace both the front and rear of the spokes, thus acting as draw-link recesses.

Thus it will be seen that, by the employment of the metallic plates *a a'*, in connection with the metallic shells or bands C C', the flanges D D' are constantly drawn and tightly held against the rear and front portions of the spokes, supporting and strengthening the shoulders at a point in a carriage-wheel always subjected to great strain.

To furthermore retain the flanges D D' close up against the front and rear part of the spokes, bolts, rivets, or screws may be inserted through the openings C C' in the flanges and pass through or between the spokes, as shown by the openings in figs. 3 and 4.

The spokes *b* may be cut away at or near their shoulders, as indicated by *f f*, fig. 1, so as to allow of a dish form to be given to the wheel.

When the spokes are inserted between the flanges D D', the shoulder *h* rests upon the metallic plates *a a'*, while the tenons *k* pass through the mortises formed in the said plates down into the mortises of the wooden hub or core A; the sides of the spokes above the shoulders, being closely joined to each other, are braced in the front and rear by the metallic flanges.

Instead of making the metal shells or bands each having its own separate and independent metallic plates with their respective mortises, the same may be formed of a single piece of metal, with but a single plate, *a*, with its mortises corresponding with the mortises in the wooden hub. In this case the flanges D D' may be formed with or screwed upon the metallic shell or band, and support the front and rear part of the spokes near the shoulder.

The hub-band E may be formed with the shell or band C, and then plated or painted, but is preferably made separate, and applied to the end of the wooden hub in the usual manner.

It will thus be seen that a neat and substantial hub

is thus produced, easily constructed, and readily adapted to any style of wooden hub, since the shell or band can be cast in any desired form.

The outer surface of the metallic shell may be plated, if desired, or it may be formed with beads, so that when painted it may represent the ordinary turned wooden hub now in use.

Having thus described my invention,

What I claim as new, and desire to secure by Letters Patent, is—

1. The metallic shells or bands C C, each carrying its own separate and independent metallic mortises, substantially as described.
2. The flanges D D', formed with or secured upon the metallic shells or bands C C, when said shells or bands each carry its own separate mortised metallic

plates a a', substantially as described, for the purpose set forth.

3. The recesses or openings e e formed between the flanges D D' and the metallic shells or bands C C, substantially as described, for the purpose set forth.

4. The metallic shells or bands C C, with the mortised plates a a' and flanges D D', in combination with the wooden hub or core A, substantially as described, for the purpose set forth.

To the above I have signed my name this 4th day of August, 1870.

SIMEON ATHA.

Witnesses:

R. N. JORDAN,
ANNIE JORDAN.