

F. J. FREESE.

CHUCK.

(Application filed Dec. 18, 1899.)

(No Model.)

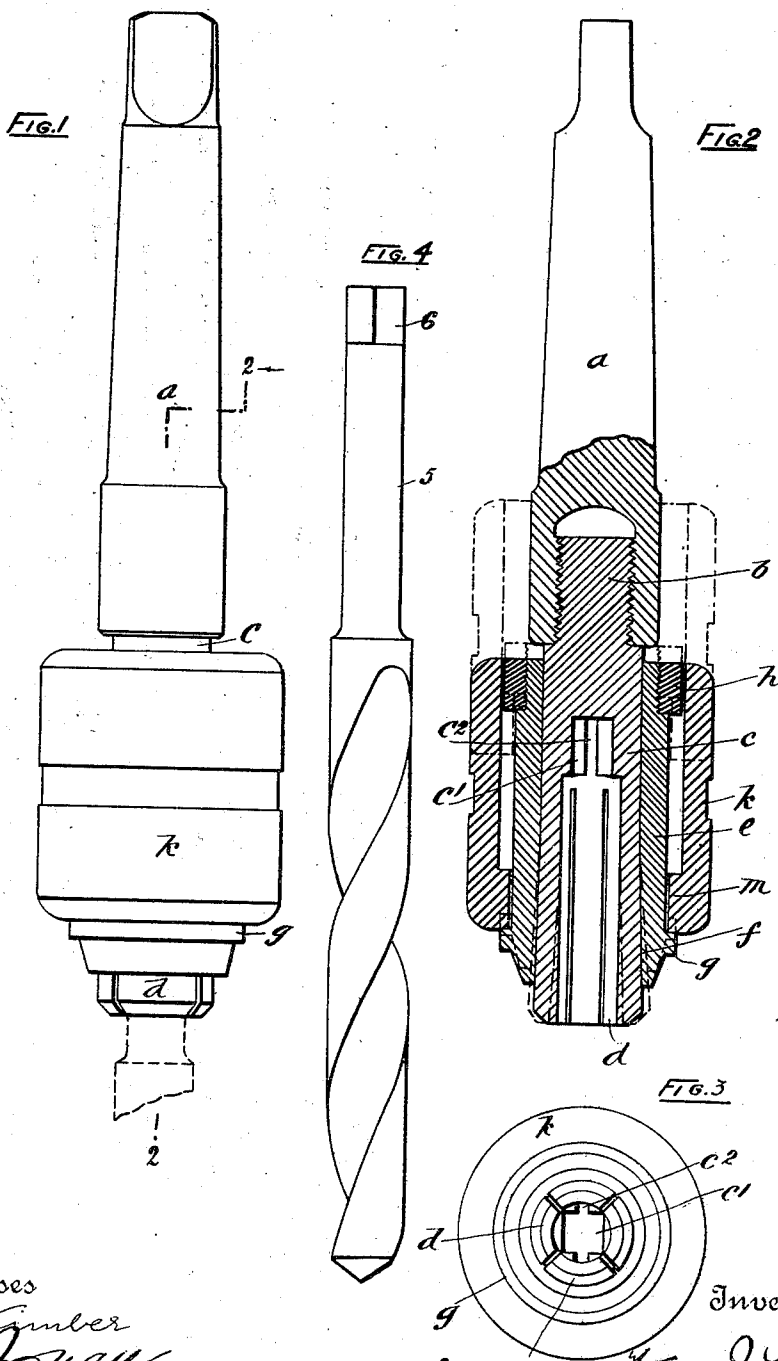

Witnesses
 Rackhamber
 W. J. Swan

Inventor
 Francis J. Freese
 By his Attorney
 Wm. N. Swan

UNITED STATES PATENT OFFICE.

FRANCIS JOSEPH FREESE, OF MONTREAL, CANADA.

CHUCK.

SPECIFICATION forming part of Letters Patent No. 668,286, dated February 19, 1901.

Application filed December 18, 1899. Serial No. 740,835. (No model.)

To all whom it may concern:

Be it known that I, FRANCIS JOSEPH FREESE, of the city of Montreal, in the district of Montreal and Province of Quebec, Canada, have invented certain new and useful Improvements in Chucks; and I do hereby declare that the following is a full, clear, and exact description of the same.

My invention has for its object to provide a chuck in which a bit can be set and firmly held and removed therefrom while the chuck is being driven and without utilizing any other device than is permanently carried by the chuck.

To this end my invention may be said, briefly, to consist of a chuck comprising a resilient expansile part to receive and grip the bit, a part carried by and to contract said expansile part, and a part carried by said contractor part to cause same to contract the expansile part and preferably consisting of a weighted part to act as a hammer to either impinge upon and drive said contractor part into contracting relation with the gripping part to cause it to grip the bit or out of such contracting relation to release the bit. For full comprehension, however, of my invention reference must be had to the accompanying drawings, forming a part of this specification, in which like symbols indicate the same parts, and wherein—

Figure 1 is a side elevation of my improved chuck; Fig. 2, a longitudinal sectional view thereof, taken on line 2 2, Fig. 1. Fig. 3 is a view looking into the mouth of the chuck, and Fig. 4 is a view of a bit constructed according to my invention.

a is the shank of my improved chuck, and the lower end thereof is formed with a screw-threaded boring in which takes the screw-threaded diminished end b of my resilient contractible part, which consists of a body portion c of less diameter than said lower end of the shank a and having a series of resilient fingers d , formed in one therewith and constituting a contractible sleeve to receive the shank of the bit, while the portion of said body portion forming the inner end of said sleeve is formed with a square socket c' , with lateral extensions c'' from two of its opposite sides, the latter being to enable a bit with a tang to be set in the sleeve. The part for con-

tracting said resilient sleeve to grip the bit 5 consists of a rigid sleeve e , having its mouth slightly flared, as at f , and formed on its exterior with a rigid collar g , while the upper 55 end thereof is diminished and screw-threaded to receive a ring h , of greater external diameter than said sleeve e and carried rigidly thereby when set in place. This contractor- 60 sleeve is of a length to have a space between its upper end and the lower end of the shank a when the flared end is in contracting relation with the resilient gripping-sleeve, as shown in full lines in Fig. 2. 65

The hammer for driving the sleeve e either into contracting relation with the gripping-sleeve d to cause it to grip the bit or out of such contracting relation to release the bit (see dotted line in Fig. 2) consists of a rigid 70 sleeve k , having the lower end of its interior diminished to provide an annular shoulder m .

In placing a bit in my improved chuck, whether it is necessary to remove a bit that may happen to be carried thereby or not, the 75 hammer k is lifted, thus causing the shoulder m to impinge upon the shoulder presented by the ring h , thereby lifting the contractor-sleeve free of the gripping-sleeve d , the resiliency of the fingers whereof will cause it to expand sufficiently to receive the shank of 80 the bit, the contractor-sleeve through the hammer meanwhile being held in its raised position. After the bit has been set in place the hammer is allowed to drop or forced 85 downward and in falling will impinge upon the collar g and drive the sleeve e upon the expanded gripping-sleeve, thereby causing it to contract and firmly grip the bit.

It is obvious that as the outer sleeve or 90 hammer is free of the chuck in so far as rotary movement is concerned and as it is the only part that need be handled to fasten the bit firmly in place such bit can with ease be set in place or removed while the chuck is 95 being driven and without any danger.

In some applications of my invention it may be desirable to dispense with the hammer-section and utilize only the resilient expansile part and the contractor part, and this can 100 be done without departing from the spirit of my invention.

I make the shank 6 of the bit 5 square in cross-section at its driven end to present a

surface that will give greater gripping power to the bit, and I have found this construction advantageous when applied to bits generally.

What I claim is as follows:

5 1. In a chuck a shank portion having a resilient expansile sleeve at one end; a rigid part carried by said shank and movable to contract said expansile sleeve; and a device
10 carried rotatably by said rigid part for moving same into or out of contracting relation with said expansile sleeve while said expansile sleeve is rotating substantially as described and for the purpose set forth.

15 2. In a chuck, the combination of a shank and a series of fingers carried by said shank, means for causing said fingers to grip the bit to be carried, and a hammer rotatably carried by said shank for acting upon said means for causing said fingers to grip or release said bit

while the shank and fingers are rotating, substantially as and for the purpose set forth.

3. In a chuck a shank portion having at one end a resilient expansile sleeve of hollow cylindrical form longitudinally split; a rigid part carried thereby to contract said expansile sleeve, a hammer consisting of a sleeve rotatably mounted upon said rigid part and having an interior collar; and a pair of rigid projections upon said rigid part and located on opposite sides of said interior collar substantially as described and for the purpose set forth.

In testimony whereof I affix my signature in presence of two witnesses.

FRANCIS JOSEPH FREESE.

Witnesses:

WILLIAM P. MCFEAT,
FRED. J. SEASS.