



US 20050044654A1

(19) **United States**

(12) **Patent Application Publication**
Ni

(10) **Pub. No.: US 2005/0044654 A1**

(43) **Pub. Date: Mar. 3, 2005**

(54) **SILENCER FOR VACUUM CLEANER**

Publication Classification

(76) **Inventor: Zugen Ni, Suzhou City (CN)**

(51) **Int. Cl.⁷ A47L 5/00**

(52) **U.S. Cl. 15/326**

Correspondence Address:

Min (Amy) S. Xu
DORSEY & WHITNEY LLP
Intellectual Property Department
50 South Sixth Street, Suite 1500
Minneapolis, MN 55402-1498 (US)

(57) **ABSTRACT**

The present invention provides a silencer for a vacuum cleaner. The silencer for the vacuum cleaner comprises at least one silencing board mounted in an exhaust channel of the vacuum cleaner for passage of an exhaust airflow from the vacuum cleaner. A plurality of pores are distributed throughout in the silencing board. The silencing board is mounted in an orientation perpendicular to the direction of the airflow through the exhaust channel. The silencer for a vacuum cleaner can considerably diminish the noise generated by the vacuum cleaner in operation.

(21) **Appl. No.: 10/726,063**

(22) **Filed: Dec. 2, 2003**

(30) **Foreign Application Priority Data**

Aug. 26, 2003 (CN) 03152869.4

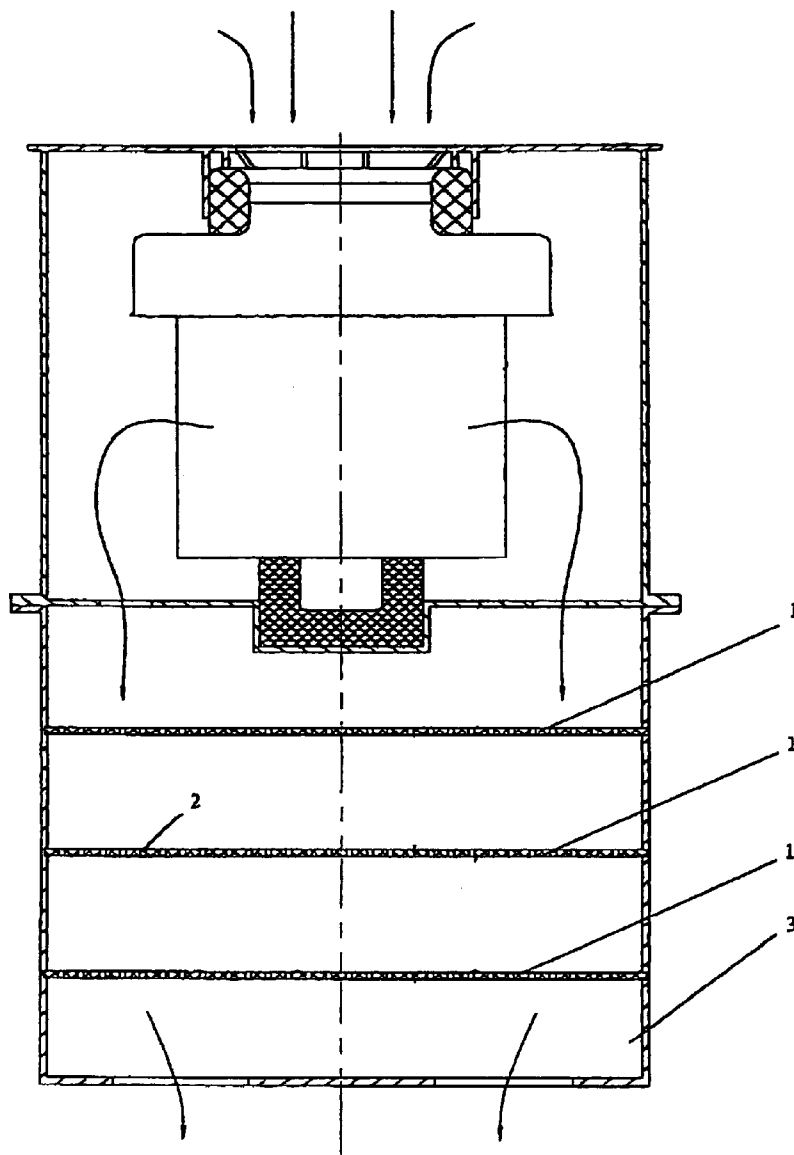

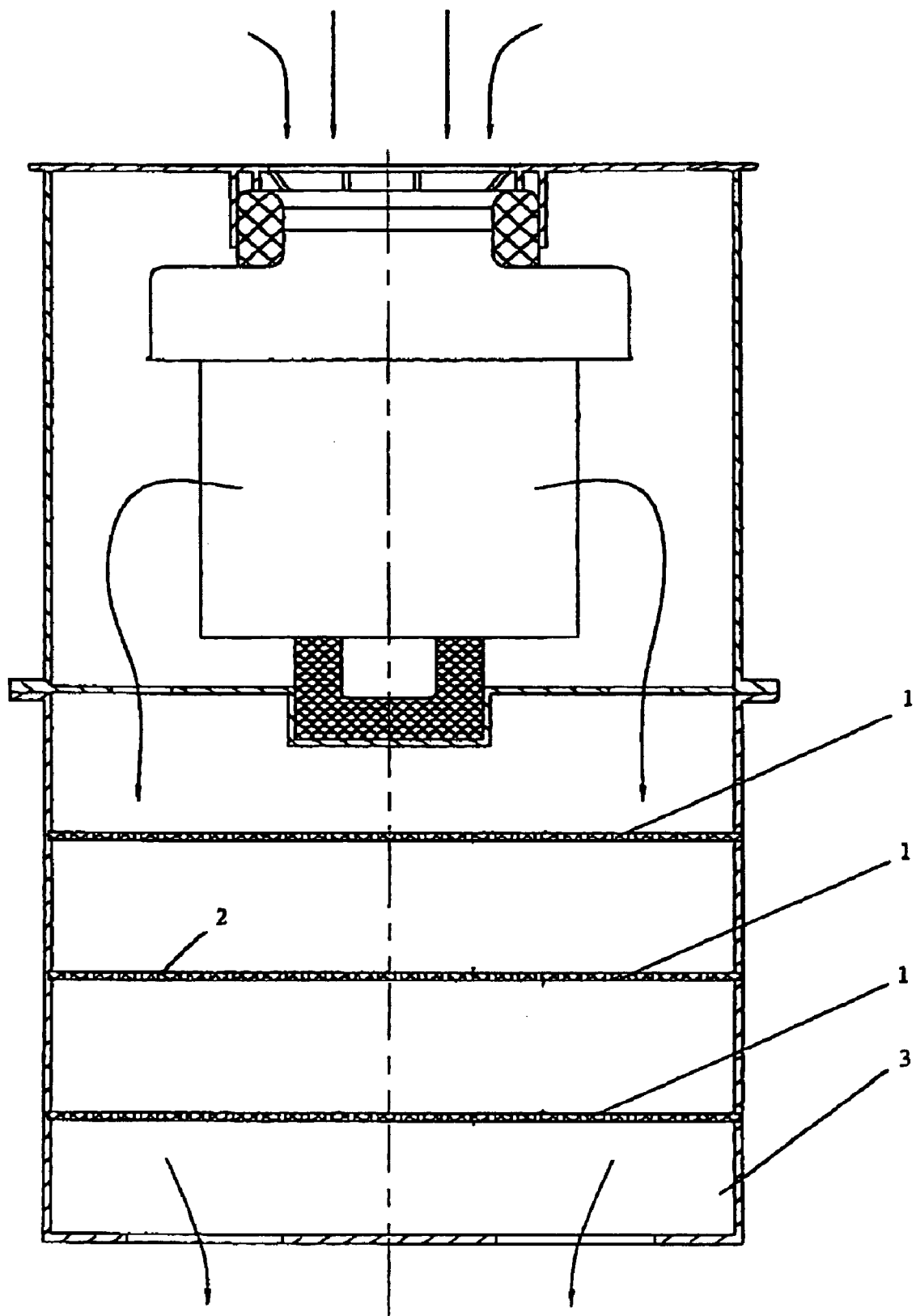

Fig. 1

SILENCER FOR VACUUM CLEANER

FIELD OF THE INVENTION

[0001] The invention relates to a silencer for a vacuum cleaner.

BACKGROUND OF THE INVENTION

[0002] In conventional exhaust air silencers for vacuum cleaners, the noise is reduced by means of increasing the tortuosity of the airflow channel, i.e. by using labyrinthic airflow channels, to dissipate sound energy and by means of disposing porous sound-absorbing materials at the turning corners of the airflow channel to absorb sound energy. Poor noise silencing effect, however, is the main disadvantage of the above-mentioned silencing structures.

SUMMARY OF THE INVENTION

[0003] The object of the invention is to provide a silencer for a vacuum cleaner, which utilizes one or more silencing boards mounted in the exhaust channel to considerably diminish the noise generated by a vacuum cleaner in operation.

[0004] In one aspect of the invention, a silencer for a vacuum cleaner comprises at least one silencing board mounted in an exhaust channel of the vacuum cleaner for passage of an exhaust airflow from the vacuum cleaner. A plurality of pores are distributed throughout in the silencing board.

[0005] In a further aspect of the invention, a silencer for a vacuum cleaner comprises at least one silencing board mounted in an exhaust channel of the vacuum cleaner for passage of an exhaust airflow from the vacuum cleaner. A plurality of pores are distributed throughout in the silencing board. The silencing board is mounted in an orientation perpendicular to the direction of the airflow passing through the exhaust channel.

[0006] In a more detailed aspect of the invention, a silencer for a vacuum cleaner comprises at least one silencing board mounted in an exhaust channel of the vacuum cleaner for passage of an exhaust airflow from the vacuum cleaner. A plurality of pores are distributed throughout in each of the at least one silencing board. The silencing board is mounted in an orientation perpendicular to the direction of the airflow through the exhaust channel. The total passage area of the pores is less than half of the cross-sectional area of the exhaust channel. The diameter of each pore in the silencing board is less than 6 mm, and wherein the thickness of the silencing board is larger than 0.5 mm.

[0007] The invention provides the following advantages:

[0008] 1. In the invention, one or more silencing boards are mounted in the exhaust channel, which can effectively diminish the noise generated by a vacuum cleaner in operation.

[0009] 2. The silencing board(s) of the invention can be directly mounted in the exhaust channel, or be mounted in

an expansion chamber connected to the exhaust channel. The latter with the silencing board(s) mounted within an expansion chamber will obtain a better effect of noise reduction.

BRIEF DESCRIPTION OF THE DRAWINGS:

[0010] **FIG. 1** is a sectional view schematically illustrating a silencer for a vacuum cleaner according to the preferred embodiment of the present invention, wherein:

[0011] the numeral **1** denotes a silencing board, **2** denotes pores, and **3** denotes an exhaust channel.

DETAILED DESCRIPTION OF THE PREFERRED EMBODIMENT

[0012] The invention is described below with reference to the preferred embodiment of the invention shown in **FIG. 1**.

[0013] As shown in **FIG. 1**, a silencer for a vacuum cleaner comprises three silencing boards **1** mounted in the exhaust channel **3**. The silencing boards **1** are generally made of plastic material or metal. A plurality of pores **2** are distributed throughout in each of the silencing boards **1**. Each of the silencing board **1** is mounted in an orientation perpendicular to the direction of the airflow passing through the exhaust channel **3**. The total passage area of the pores **2** in each of the silencing boards **1** is less than half of the cross-sectional area of the exhaust channel **3**. The diameter of each of the pores **2** in the silencing boards **1** are less than 6 mm and the thickness of each of the silencing boards **1** is larger than 0.5 mm.

[0014] In the invention, one or more silencing boards **1** are mounted in the exhaust channel **3**, which can effectively reduce the noise generated by a vacuum cleaner in operation. The silencing board(s) **1** of the invention can be directly mounted in the exhaust channel **3**, or be mounted in an expansion chamber connected to the exhaust channel **3**. The latter with the silencing board(s) mounted within an expansion chamber will obtain a better effect of noise reduction.

1. A silencer for a vacuum cleaner, which comprises at least one silencing board mounted in an exhaust channel of the vacuum cleaner for passage of an exhaust airflow from the vacuum cleaner, with a plurality of pores (**2**) distributed throughout in the silencing board.

2. A silencer for a vacuum cleaner according to claim 1 wherein the silencing board is mounted in an orientation perpendicular to the direction of the airflow passing through the exhaust channel.

3. A silencer for a vacuum cleaner according to claim 1 wherein the total passage area of the pores is less than half of the cross-sectional area of the exhaust channel.

4. A silencer for a vacuum cleaner according to claim 1 wherein the diameter of each of the pores in the silencing board is less than 6 mm.

5. (Cancelled).

* * * * *