

S. B. MILLER.  
Seeding-Machines.

No. 137,708.

Patented April 8, 1873.

Fig. 1.

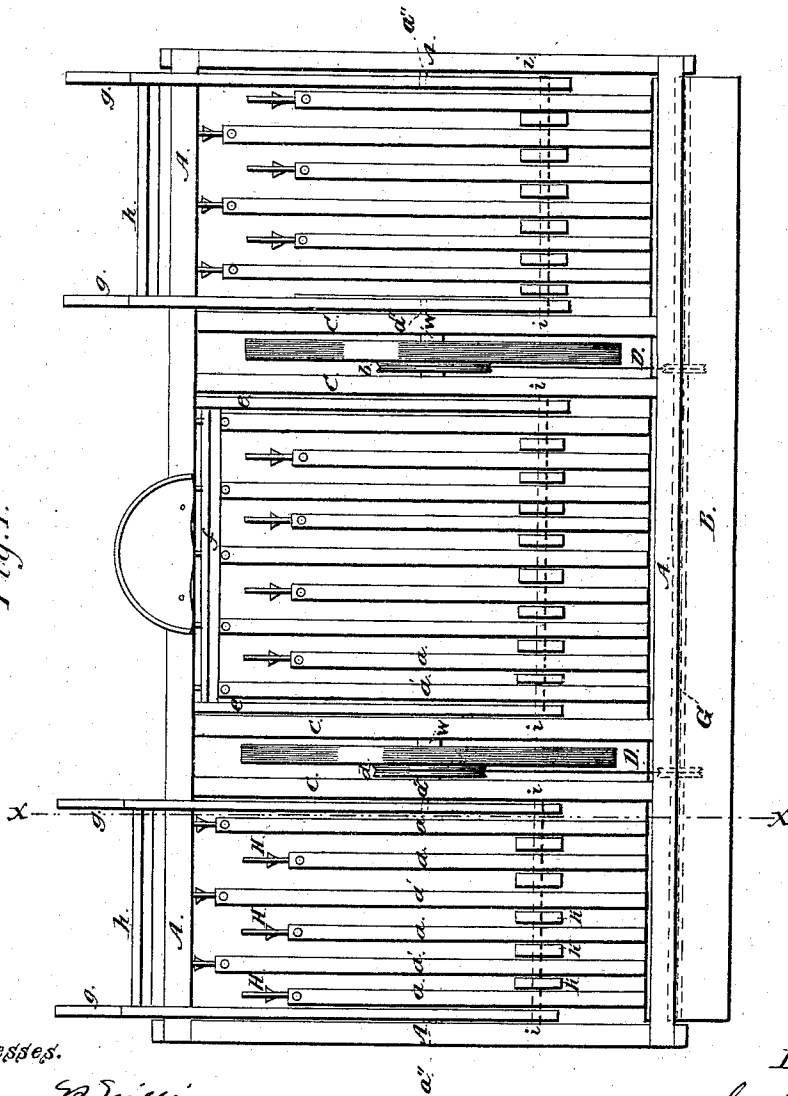

Witnesses.

James B. Williams  
M Gardner

Inventor.

Saml B Miller

S. B. MILLER.  
Seeding Machines.

No. 137,708.

Patented April 8, 1873.

Fig. 2.

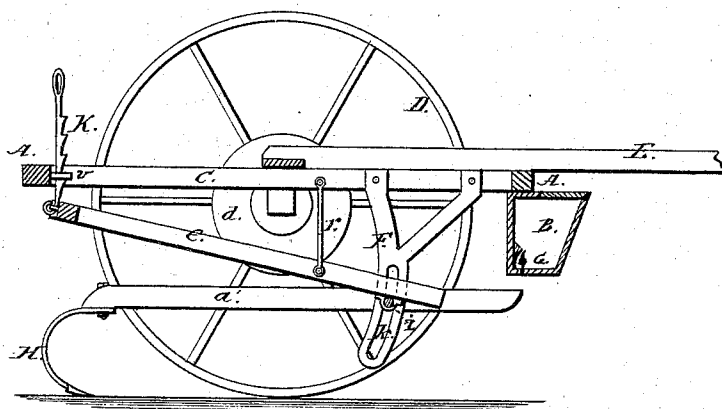

Fig. 3.

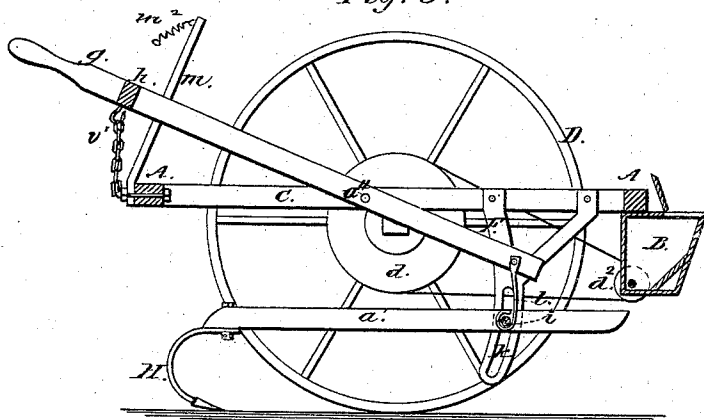

Fig. 4.

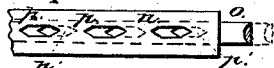
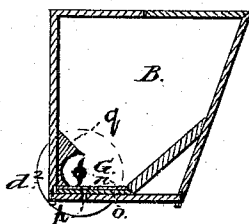

Fig. 5.

Witnesses.  
James B. Williams  
M. Gardner,

Inventor.  
Sam<sup>l</sup>. B. Miller

# UNITED STATES PATENT OFFICE.

SAMUEL B. MILLER, OF STANWOOD, IOWA.

## IMPROVEMENT IN SEEDING-MACHINES.

Specification forming part of Letters Patent No. **137,708**, dated April 8, 1873; application filed August 12, 1872.

To all whom it may concern:

Be it known that I, SAMUEL B. MILLER, of Stanwood, Iowa, have invented certain Improvements in Seeding-Machines, of which the following is a specification:

The first part of my invention relates to a combination of seed-box, an S-shaped feed-shaft, and discharge-plates, in such a manner that when the shaft receives its rotary motion it carries an equal amount of grain to the discharge-orifices at each revolution or part of revolution of the shaft. The second part of my invention relates to a combination of cultivator-bars provided with shovels, and the arrangement of levers on the main frame for the adjustment of the cultivator-bars to any required depth when seeding.

In the drawing, Figure 1, Plate 1, is a view in plan of the machine, in which A A A A is a rectangular frame bearing seed-box B and cross-pieces C, which contain and support the axle W, upon which the wheels D D are set. *g g* are levers, which are united at the outer ends by the cross-bars *h h*, and are poised in the frame A A at the points *a' a'*. The levers *g g* have thus a vertical movement at their ends adjacent to the seed-box B, where they are attached to pendants *l*, which form attachment at their lower ends with rod *i*, as shown in Fig. 2, upon which are suspended the cultivator-bars *a' a' a'*. The ends of these bars pass under the seed-box B, so that when the bars *h* are pressed down the rod *i* is raised, throwing the ends of *a'* against the bottom of B, and thus raising the shovels H out of and above the ground. *h'* are blocks separating the cultivator-bars. *d* is a pulley, which operates the feed-shaft G.

Fig. 2, Sheet 2, is a sectional view on a line in the direction of the draft, midway between the wheels D D, and which I regard as a modification of my invention, in which the same principle is used as in Fig. 1, Sheet 1, except the levers are swung beneath instead of projecting above brace-bars C C, turning about a pivot at the lower end of pendant *r*, and fastened loosely to the cultivator-arms *a'* at *i*. F is a vertical guide-brace. K is a ratchet-iron for adjusting the pitch of the shovels H.

Fig. 3 is a similar section on a line between the wheels D and end bars A, showing a ful-

crum, *a''*, and hook and chain *v'*. Pendent rod *l* may attach rod *i* to the lever *g*. *d<sup>2</sup>* is a pulley to operate the feed-shaft in the box B by means of a belt in connection with the pulley *d*.

Fig. 4 is a sectional view of the seed-box. G is the feed-shaft, S-shaped in cross-section. *p* is the discharge-orifice, gaged in size by means of the movable plate *o*. *q* is a shield, semicircular about the axis G, coming up immediately over the shaft G when vertical, and inclined up and back on the top so as to throw the seed forward into the bottom of the box. The front of the box is also inclined to throw the seed against the shaft G.

Fig. 5 is a view of stationary plate *n* and movable plate *o*, showing how the elongated diamond end feed-orifices are gaged, so as to pass any required amount of seed.

The operation of this machine is as follows: Seed is placed in the box B; the levers are adjusted so as to sink the shovels to the required depth. When the machine is started the pulley *d* communicates rotary motion to the feed-shaft G. The wings of this shaft in coming down scoop forward a quantity of the seed. The orifices *p* will permit the required quantity to fall through according as they are gaged, and the balance is carried forward over the shaft and delivered again into the box B.

I know that a feed-shaft has been made where the supply is regulated by varying the shaft-buckets, but they depend for their action on the certainty of the seed flying clear from the buckets as it passes over the orifices.

Others have been made upon the same principle to discharge through a common orifice, using a screw-shaft. They are very liable to clog, and the tendency is to work the grain all into one end of the box.

I make the orifice long and arrow-shaped at the extremities; as it is found to deliver long seed with greater regularity than any other form of orifice. The seed is covered under by the shovels H H.

Having thus described my invention, what I claim as new, and desire to secure by Letters Patent, is—

1. The combination, with the frame A A A

A, of the seed-box B, levers *g g*, bars *a a'*, vertical guide-braces F, and fastenings *v'*, constructed and operated substantially as set forth.

2. The semicircular shield *q*, in combination with the S-shaped shaft G, substantially as shown and described.

3. The feed-box B provided with adjustable

plates *n* and *o* and semicircular deflector *q*, in combination with S-shaped shaft G, substantially as shown and described.

SAML. B. MILLER.

Witnesses:

JAMES B. WILLIAMS,  
M. GARDNER.