

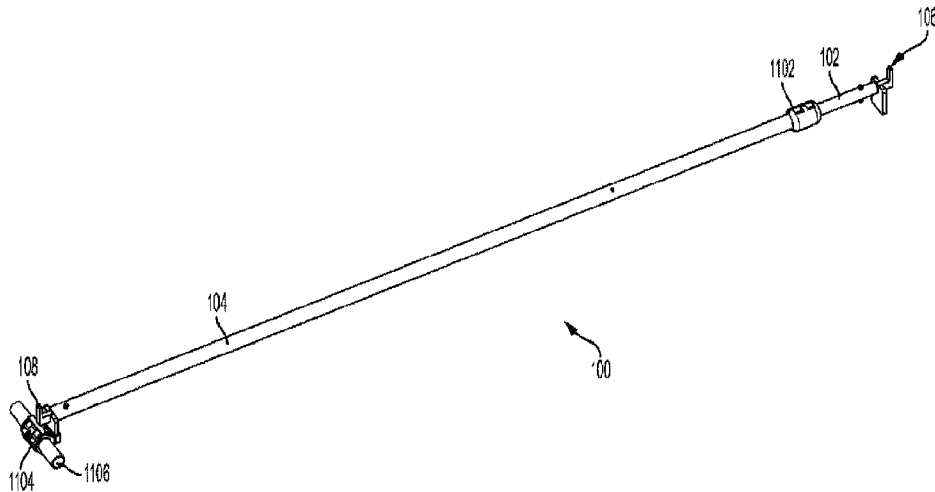

(86) Date de dépôt PCT/PCT Filing Date: 2020/07/29
 (87) Date publication PCT/PCT Publication Date: 2021/02/04
 (45) Date de délivrance/Issue Date: 2023/11/28
 (85) Entrée phase nationale/National Entry: 2022/01/24
 (86) N° demande PCT/PCT Application No.: US 2020/043998
 (87) N° publication PCT/PCT Publication No.: 2021/021881
 (30) Priorité/Priority: 2019/07/29 (US62/879,793)

(51) Cl.Int./Int.Cl. *B65D 19/38* (2006.01)
 (72) Inventeurs/Inventors:
 HENDERSON, DYLAN, US;
 ALBERS, DAVID, US;
 BELIN, MARK, US
 (73) Propriétaire/Owner:
 INNOVATIVE LOGISTICS, LLC, US
 (74) Agent: GOWLING WLG (CANADA) LLP

(54) Titre : POUTRE D'ETAYAGE REGLABLE ET ENSEMBLE CROCHET
 (54) Title: ADJUSTABLE SHORING BEAM AND HOOK ASSEMBLY



(57) **Abrégé/Abstract:**

Disclosed herein is an adjustable shoring beam having a hook assembly configured to mate with E-track mating features. The adjustable shoring beam can be adjusted over a predetermined length range by adjusting the tube assembly and the rod assembly. In some embodiments, the extension length is fixed using a fixing clamp coupled to the tube assembly and the rod assembly. A connecting clamp and bracket may be used to couple a first adjustable shoring beam to a second adjustable shoring beam.

Date Submitted: 2022/01/24

CA App. No.: 3145407

Abstract:

Disclosed herein is an adjustable shoring beam having a hook assembly configured to mate with E-track mating features. The adjustable shoring beam can be adjusted over a predetermined length range by adjusting the tube assembly and the rod assembly. In some embodiments, the extension length is fixed using a fixing clamp coupled to the tube assembly and the rod assembly. A connecting clamp and bracket may be used to couple a first adjustable shoring beam to a second adjustable shoring beam.

ADJUSTABLE SHORING BEAM AND HOOK ASSEMBLY

Cross-reference to related applications

5 [0001] This application claims priority to U.S. Provisional Application Serial
No. 62/879,793, filed July 29, 2019.

Field of the invention

10 [0002] The present invention is directed to an adjustable shoring beam that
prevents the movement of freight. This invention is intended to be used with E-track
mating features such as those found on the vertical posts and decks of a movable
platform described in U.S. Patent No. 10,279,955, issued May 7, 2019. The adjustable
shoring beam may engage surfaces containing E-track mating features which are
parallel and/or perpendicular to the length of the beam.

Background

15 [0003] Adjustable shoring beams are used in securing freight in trailers or on
loading platforms. Current adjustable shoring beams typically rely on a rudimentary
locking system, if any, to maintain the adjustable shoring beam at a fixed length.
These shoring beams can be difficult to adjust. Further, the use of the adjustable
shoring beams is limited to horizontal use between mating features due to their
design. Therefore, there exists a need for an adjustable shoring beam that can easily
20 be adjusted and secured in a variety of configurations.

Summary

25 [0004] Disclosed herein is an adjustable shoring beam configured to mate with
E-track mating features. The adjustable shoring beam can be adjusted over a
predetermined length range by adjusting the tube assembly and the rod assembly. In
some embodiments, the extension length is fixed using a fixing clamp coupled to the

tube assembly and the rod assembly. A connecting clamp and bracket may be used to couple a first adjustable shoring beam to a second adjustable shoring beam.

Brief description of the drawings

- 5 [0005] Fig. 1 depicts an isometric view of a first embodiment of the adjustable shoring beam.
- [0006] Figs. 2A-2C depict various views of the tube assembly in isolation.
- [0007] Figs. 3A-3B depict various views of the rod assembly in isolation.
- [0008] Fig. 4 depicts a partial cutaway of the tube assembly inserted into the
- 10 rod assembly to show the positioning of a compression spring.
- [0009] Figs. 5A-5B depicts the coupling of the hook assembly to the rod assembly.
- [0010] Figs. 6A-6C depicts the coupling of the hook assembly to the tube assembly.
- 15 [0011] Figs. 7A-7C depict various views of the hook assembly in isolation.
- [0012] Figs. 8A-8C depict various views of the securement plate in isolation.
- [0013] Figs. 9A-9C depict various views of the securement hook in isolation.
- [0014] Figs. 10A-10C depict the adjustable shoring beam coupled to vertical posts of a movable platform.
- 20 [0015] Fig. 11 depicts another embodiment of an adjustable shoring beam.
- [0016] Figs. 12 and 13 depict an alternate embodiment of the first hook assembly and the second hook assembly.
- [0017] Fig. 14 depicts the coupling of the sliding rod assembly to the first hook assembly.
- 25 [0018] Figs. 15 and 16 depict cutaway views showing the connection between the sliding rod assembly and the tube assembly using a fixing clamp.
- [0019] Fig. 17 depicts the fixing clamp in phantom coupled to the end of the tube assembly.
- [0020] Figs. 18 and 19 depict views of the fixing clamp in isolation.
- 30 [0021] Figs. 20 and 21 depict the first handle and the first latch member in isolation.

[0022] Fig. 22 depicts a perspective view of the second handle and second latch member in isolation.

[0023] Fig. 23 depicts a perspective view of the fixing clamp in an open configuration.

5 [0024] Figs. 24 and 25 depict interior views of the clamp body in isolation.

[0025] Figs. 26 and 27 depict interior views of the first arcuate member and the second arcuate member together.

[0026] Fig. 28 depicts a perspective view of the connection assembly coupled to the tube assembly.

10 [0027] Fig. 29 depicts a perspective view of the connection clamp without the bracket.

[0028] Fig. 30 depicts a rear view of the connection clamp in isolation.

[0029] Fig. 31 depicts an interior view of the first arcuate member of the connection clamp.

15 [0030] Fig. 32 depicts an interior view of the second arcuate member of the connection clamp.

[0031] Fig. 33 depicts the connection clamp in an open configuration.

[0032] Figs. 34-36 depict views of the bracket in isolation.

20 [0033] Figs. 37-39 depict the connection assembly used to couple a first adjustable shoring beam to a second adjustable shoring beam.

[0034] Figs. 40-44 depict the steps utilized to couple a first adjustable shoring beam to a second adjustable shoring beam.

[0035] Fig. 45 depicts a related art method used to secure freight and cargo to a movable platform.

25 [0036] Fig. 46 depicts how a plurality of adjustable shoring beams with connecting structures can be used to secure freight and cargo to a movable platform.

Detailed description

[0037] Referring to Fig. 1, depicted is an adjustable shoring beam 100.

30 Conventional shoring beams are common load-bearing freight securement devices that extend and retract with ends that lock into track systems, i.e. E-track and A-track.

Adjustable shoring beam 100 is adjustable by sliding rod assembly 102 within tube assembly 104 to accommodate a range of usable lengths.

[0038] Rod assembly 102 and tube assembly 104 are depicted as having circular cross-section. However, it should be apparent that any cross-section can be utilized as long as rod assembly 102 can slide within tube assembly. Other possible compatible cross-section shapes include square, rectangular, oval, quadrilateral, round in square, oval in rectangle, etc.

[0039] Rod assembly 102 is coupled to a first hook assembly 106 and tube assembly 104 is coupled to a second hook assembly 108. First hook assembly 106 and second hook assembly 108 are used to secure adjustable shoring beam 100 to a movable platform. Rod assembly 102, first hook assembly 106, tube assembly 104, and second hook assembly 108 are all preferably formed from steel, such as ASTM A36 steel. However, it should be obvious that any industrial grade metal (or even strong plastic) can be used in their construction.

[0040] First hook assembly 106 is preferably coupled to rod assembly 102 through welding. Similarly, second hook assembly 108 is preferably coupled to tube assembly 104 through welding. However, any connection method may be used in place of welding.

[0041] Figs. 2A-2C depict tube assembly 104 in isolation without first hook assembly 106. Tube assembly 104 comprises slot 202 which limits the expansion/contraction length of adjustable shoring beam 100 as will be described later.

[0042] In a preferred embodiment, tube assembly 104 has a total length of ~81", an inner circumference of ~0.8", and an outer circumference of ~1.09". Slot 202 preferably has a length of 14" and a width of ~0.25", with a first end of slot 202 starting ~3.25" from an end of tube assembly 104.

[0043] Figs. 3A-3C depict rod assembly 102 in isolation. Rod assembly 102 preferably has a solid cross-section that is ~0.75" in diameter. In a preferred embodiment, rod assembly 102 has a total length of 20.5". Rod assembly 102 further comprises screw hole 302 which has a threaded interior (12-28 Unified National Fine

Threads). A center of screw hole 302 is approximately 0.63" from an end of rod assembly 102.

[0044] Fig. 4 depicts a partial cutaway of the tube assembly 102 inserted into rod assembly 104. A screw, 404 is placed through slot 202 and is threaded into screw hole 302 to prevent the separation of tube assembly 102 from rod assembly 104. The length of slot 202 also limits the expansion or contraction of adjustable shoring beam 100.

[0045] Compression spring 402, which is internal to tube assembly 102, is compressed by rod assembly 104 and provides force which maintains adjustable showing beam 100 in a fully expanded configuration unless a compression force is applied. In a preferred embodiment, one end of the spring is coupled to a stopper within tube assembly 102, preventing that end of the spring from moving and allowing a compression or stretching force to be applied to the spring.

[0046] Figs. 5A-5B depicts the coupling of the first hook assembly 106 to the rod assembly 102. As shown, the centerline of the first hook assembly 106 is offset from the centerline of the rod assembly 102. This offset allows freight to be loaded to the maximum extent on the movable platform and still be secured as will be shown later. Preferably, a center of rod assembly 102 is coupled to first hook assembly 106 a distance ~0.56" from a top and ~0.56" from a left side of first hook assembly 106 in order to provide the offset.

[0047] Figs. 6A-6C depict the coupling of second hook assembly 108 to tube assembly 104. As shown, the centerline of the second hook assembly 108 is offset from the centerline of the tube assembly 104. Preferably, a center of tube assembly 104 is coupled to second hook assembly 108 a distance ~0.56" from a top and ~0.56" from a left side of second hook assembly 108 in order to provide the offset.

[0048] Figs. 7A-7C depict various views of both first hook assembly 106 and second hook assembly 108 in isolation (preferably identical in construction). As shown, first hook assembly 106 comprises securement plate 702 which is coupled to securement hook 704. Securement plate 702 and securement hook 704 are preferably formed separately by molding and later joined together by welding. First hook assembly 106 and second hook assembly 108 are configured to mate with a mating

feature known in the industry as an E-Track. In Figs. 7A-7C, the drawings represent the plate 702 to be in the 6:00 position and the hook 704 in the 12:00 position. The plate 702 could also be in the 3:00 or 9:00 position relative to the hook 704 and retain the capacity to engage E-track on the posts or floor.

5 [0049] Figs. 8A-8C depict various views of securement plate 702 in isolation. As shown, securement plate 702 is preferably rectangular in shape with a height of ~2.75" and a width of ~2.25". Each corner is preferably chamfered or curved with a radius of ~0.25". Securement plate 702 preferably has a thickness of ~0.38".

[0050] Securement plate 702 further comprises cutout 802 which is used when
10 joining securement hook 704. Cutout 802 is preferably arranged along a top of securement plate 702 at the center. Cutout 802 is preferably ~0.55" in width and ~0.75" in height.

[0051] Figs. 9A-9C depict various views of securement hook 704 in isolation. Securement hook 704 is generally L-shaped having securement section 902 and
15 perpendicular hook section 904. Securement section 902 is preferably ~1.5" in width and ~0.75" in height. Hook section 904 is preferably ~0.375" in width and ~1.5" in height, making the overall dimensions of securement hook 704 ~1.5" in width and ~2.25" in height. Both securement section 902 and hook section 904 are preferably 0.5" in thickness. Securement section 902 is placed within cutout 802 and welded
20 together to form first hook assembly 106 as depicted in Figs. 7A-7C.

[0052] Shoring beams of a similar nature are commonly available within the industry to span trailer walls to secure freight. However, these existing beams only allow for securement between mating E-track features in two parallel planes which are perpendicular to the length of the beam. However, the shape of securement hook
25 704 allows adjustable shoring beam 100 to be used between mating E-Track features which are (a) perpendicular to a length of adjustable shoring beam 100 or (b) parallel to the length of the adjustable shoring beam 100, such as the floor of a movable platform.

[0053] Figs. 10A-10C depict the use of adjustable shoring beam 100 to span
30 vertical posts 1002 and 1004. As best shown in Figs. 10B and 10C, the offset (e.g., between rod assembly 102 and first hook assembly 106) allows more cargo to be

placed on the movable platform because of the additional room provided by adjustable shoring beam 100 (e.g., ~1.5") on each side of the movable platform while still providing the required shoring strength.

[0054] Fig. 11 depicts an alternate embodiment of adjustable shoring beam 5 100. In this embodiment, the length of adjustable shoring beam is fixed using fixing clamp 1102 which locks the positions of sliding rod assembly 102 and tube assembly 104 relative to each other. Further disclosed in this embodiment is mating clamp 1104 which allows a first adjustable shoring beam 100 to be coupled to a second adjustable shoring beam 1106 in a T-configuration as depicted.

10 [0055] This embodiment does not include slot 202, screw hole 302, or screw 404. Further, first hook assembly 106 is detachably coupled to sliding rod assembly 102 and second hook assembly 108 is detachable coupled to tube assembly 104 as will be described later.

[0056] In the embodiment described in Figs. 1-10C, the first hook assembly 15 106 is permanently attached to sliding rod assembly 102. In this embodiment, first hook assembly 106 and second hook assembly comprise peg 1202 which is secured to a rear of securement plate 702 via welding as depicted in Figs. 12 and 13. Peg 1202 is preferably solid and formed from the same metal as the rest of adjustable shoring beam 100. Peg 1202 comprises bore 1204 and bore 1206 which are spaced apart from 20 each other and arranged in an X-pattern. A bolt 1208 is placed through bore 1204 or 1206 and then a nut is placed on the opposing end to secure first hook assembly 106 to sliding rod assembly 102. By having two bores 1204, and 1206, the first hook assembly 106 can be secure in a first position or a second position perpendicular to the first position.

25 [0057] Fig. 14 depicts the coupling of sliding rod assembly 102 to first hook assembly 106. Both sliding rod assembly 102 and peg 1202 are shown in phantom so the coupling can be observed. As shown, peg 1202 is inserted into an open end of sliding rod assembly 102. Either bore 1204 or bore 1206 is then lined up with corresponding through holes on sliding rod assembly 102. Bolt 1208 is placed 30 through bore 1206, for example, and then secured with nut 1210 on an opposing side

of sliding rod assembly 102. Second hook assembly 108 is secured to tube assembly 104 in an identical manner.

[0058] Figs. 15 and 16 depict cutaway views of the ends of adjustable shoring beam 100 showing the connection between sliding rod assembly 102 and tube assembly 104 using fixing clamp 1102. Tube assembly 104 is shown in phantom in both drawings to show how rod assembly 102 is inserted and slides within tube assembly 104. Fixing clamp 1102 is adjustable between an open and a closed position. When fixing clamp 1102 is open, the length of adjustable shoring beam 100 can be adjusted by sliding rod assembly 102 in/out of tube assembly 104. Closing fixing clamp 1102 locks movement of sliding rod assembly 102 with respect to tube assembly 104. Rod assembly 102 can be replaced by removing it from the end of tube assembly 104 when fixing clamp 1102 is in the open position. This also allows fixing claim 1102 to be replaced. Fixing clamp 1102, rod assembly 102, or tube assembly 104 can all be interchanged with other adjustable shoring beams 100, if need, for maintenance or repair. This allows all parts of adjustable shoring beam 100 to be replaced if needed, including first hook assembly 106 and second hook assembly 108.

[0059] As should be obvious, the diameter of rod assembly 102 is less than that of tube assembly 104 so that rod assembly 102 can slide within tube assembly 104. In order to accommodate the differing diameters, fixing clamp 1102 has a construction in which a first side has an inner diameter that is smaller than that of a second side. Fig. 17 depicts fixing clamp 1102, shown in phantom, fixed to an end of tube assembly 104. The end of tube assembly 104 preferably comprises protrusions 1702 which engage with an interior of fixing clamp 1102 when it is in the closed position. Protrusions 1702 are preferably formed of a plurality of circular and evenly spaced rings. However, protrusions 1702 may also be formed from a single spiral, similar to a raised thread on the exterior of rod assembly 102.

[0060] Figs. 18 and 19 depict views of fixing clamp 1102 in isolation. Fixing clamp 1102 comprises clamp body 1802, first arcuate member 1804, first handle 1806, second arcuate member 1808, second handle 1810, first latch member 1812, second latch member 1814, first opening 1816, and second opening 1818. First

opening 1816 is sized to accommodate rod assembly 102 whereas second opening 1818, which is larger than first opening 1816, is sized to accommodate tube assembly 104. Fixing clamp 1102 functions in a similar manner to a quick clamp used to grip circular bars. However, fixing clamp 1102 is able to simultaneously grip circular bars of different diameters as will be described.

5 [0061] First arcuate member 1804 is rotatable with respect to clamp body 1802 about first hinge 1820. First hinge 1820 is formed by a pin placed through first hinge section 1822 of first arcuate member 1804 and into body hinge section 1824 of clamp body 1802.

10 [0062] Second arcuate member 1808 is rotatable with respect to clamp body 1802 about second hinge 1826. Second hinge 1826 is formed by a pin placed through second hinge section 1828 and into body hinge section 1824. In some embodiments, a single pin may be used and inserted through first hinge section 1822, body hinge section 1824, and second hinge section 1828 simultaneously.

15 [0063] First latch member 1812 comprises first latch body 1834 and first latch extension 1836. A pin is placed through clamp body 1802, through first latch body 1834, and into second body hinge section 1832 so that first latch member 1812 is rotatable with respect to clamp body 1802 about first latch hinge 1832.

[0064] Second latch member 1814 comprises second latch body 1838 and second clamp extension 1840. A pin is placed through clamp body 1802, through second latch body 1838, and into second body hinge section 1832 so that second latch member 1812 is rotatable with respect to clamp body 1802 about second latch hinge 1842.

25 [0065] Figs. 20 and 21 depict first handle 1806 and first latch member 1812 in isolation to show how they are coupled together. As best depicted in Fig. 20, first handle 1806 is U-shaped. The end of first latch arm 1842 comprise first openings 2002. A first latch arm 1842 is coupled to first arcuate member 1804 by a pin placed through first arcuate projection 1846 and into first latch arm 1842, with the pin's extension terminating before first latch extension 1836.

30 [0066] Similarly, a pin is placed through opening 2004 in first latch arm 1844 and first arcuate projection 1848. A first end of the pin terminates at first latch

extension 1836 and a second end of the pin terminates before second arcuate member 1850.

[0067] First latch extension 1836 has a channel 2008 which aligns with channel 2006 in first latch arm 1842 and channel 2010 in second latch arm 1842. A
5 pin is placed through channel 2006, channel 2008, and channel 2010. A first end of the pin terminates at an end of channel 2006 and a second end of the pin terminates at an end of channel 2010. The pin rotatably couples first handle 1806 to first latch member 1812.

[0068] Fig. 21 depicts a side view of the coupling between first latch member
10 1812 and first handle 1806. As shown, opening 2002 terminates at first latch extension 36 whereas channels 2006, 2008, and 2010 form a continuous channel.

[0069] Fig. 22 depicts second handle 1810 and second latch member 1814 in isolation to show how they are coupled together. Second handle 1810 is U-shaped. The end of second latch arm 1854 comprises opening 2002. A second latch arm 1854
15 is coupled to second arcuate member 1808 by a pin placed through second arcuate projection 1850 and into second latch arm 1854, with the pin's extension terminating before second latch extension 1840.

[0070] Similarly, a pin is placed through opening 2204 in second latch arm 1856 and second arcuate projection 1852. A first end of the pin terminates at second
20 latch extension 1840.

[0071] Second latch extension 1840 has a channel 2208 which aligns with channel 2206 in second latch arm 1854 and channel 2210 in second latch arm 1856. A pin is placed through channel 2206, channel 2208, and channel 2210. A first end of the pin terminates at an end of channel 2206 and a second end of the pin terminates at
25 an end of channel 2210. The pin rotatably couples second handle 1810 to second latch member 1814.

[0072] As shown in Fig. 23, lifting first handle 1806 allows clamp body 1802 and first arcuate member 1804 to rotate relative to each other about hinge 1820. The rotation is limited through the coupling of first latch member 1812 to clamp body
30 1802 and first handle 1806 to first arcuate member 1804. By opening and closing first handle 1802, the rod assembly 102 can be moved and then locked in position.

[0073] Lifting second handle 1810 allows clamp body 1802 and second arcuate member 1808 to rotate relative to each other about second hinge 1826. The rotation is limited through the coupling of second latch member 1814 to clamp body 1802 and second handle 1810 to second arcuate member 1808. By opening and closing second handle 1810, the tube assembly 104 can be moved and then locked in position. Fig. 17 depicts fixing clam 1102 coupled to tube assembly 104 when second handle 1810 is in the closed position.

[0074] Figs. 24 and 25 depict the interior of clamp body 1802 in isolation. A first side 2402 of clamp body 1802 has at least two or more arcuate ribs 2404 having a first curvature. A second side 2406 has a plurality of arcuate ribs having a second curvature larger than the first curvature. A rib at the boundary of first side 2402 and second side 2404 has a first side with the first curvature and a second stepped side having the second curvature.

[0075] The first curvature is preferably the same or slightly smaller than that of rod assembly 102 so that rod assembly 102 can be gripped by fixing clamp 1102 when first handle 1806 is in the closed position. Arcuate ribs 2402 may be covered with a friction surface such as a rough plastic or metal. The covering of arcuate ribs 2402 may also comprise a compressible material to accommodate a range of sizes of rod assembly 102.

[0076] The second curvature is preferably the same or slightly smaller than that of tube assembly 104, but still greater than the first curvature. This allows arcuate ribs 2408 to grip tube assembly 104 when second handle 1810 is in the closed position and depicted in Fig. 17. The stepped rib having both curvatures at the intersection of first side 2402 and second side 2404 prevents rod assembly 104 being inserted into fixing clamp 1102 past the end of second side 2406, even when the second handle 1810 is in the open position.

[0077] The area between arcuate ribs 2404 and arcuate ribs 2408 is preferably recessed, smoothed, and curved. This allows clamp body 1802 to have reduced weight.

[0078] Clamp arm 2410, clamp arm 2412, and second body hinge section 1830 all have channels for the aforementioned described pins. In some embodiments,

a single pin is inserted into clamp arm 2410, first latch body 1834, second body hinge section 1830, second latch body 1838, and clamp arm 2412. Similarly, a single long pin can be inserted through second hinge section 1828, body hinge section 1824, and first hinge section 1822 to simultaneously form first hinge 1820 and second hinge
5 1826 as already described.

[0079] Figs. 26 and 27 depict the interiors of first arcuate member 1804 and second arcuate member 1808 in isolation. First arcuate member 1804 and second arcuate member 1808 are able to rotate independently of each other about first hinge 1820 and second hinge 1826.

10 [0080] First arcuate member 1804 comprises at least two arcuate ribs 2602 having the first curvature. Arcuate ribs 2602 in combination with arcuate ribs 2408 form opening 1816 of fixing clamp 1102.

[0081] Second arcuate member 1810 comprises at least two arcuate ribs 2604 having the second curvature. Arcuate ribs 2604 in combination with arcuate ribs 2404
15 form opening 1818. It should be apparent to one of ordinary skill in the art that the number of ribs for arcuate ribs 2404, 2408, 2602, and 2604 may be increased if required or needed.

[0082] Turning next to Fig. 28, depicted is connection assembly 2800 which can be utilized to connect any adjustable shoring beam 100 to another adjustable
20 shoring beam 100 at a perpendicular angle. Connection assembly 2800 generally comprises bracket 2802 and connection clamp 2804. Connection clamp 2804 is configured to slide anywhere along tube assembly 104 or rod assembly 102 and locked in position. Fig. 28 depicts connection assembly located on a tube assembly 104 of an adjustable shoring beam 100. However, it should be apparent that
25 connection assembly 2800 can be utilized to couple any item ending with an E-track hook to a pole or an adjustable shoring beam 100.

[0083] Connection clam 2804 is depicted in Fig. 29 without bracket 2802. The parts of connection clamp 2804 are preferably formed from injection molded plastic and the pins used for the hinges are steel. Connection clamp 2802 generally
30 comprises first arcuate member 2902, second arcuate member 2904, latch 2908, and handle 2910. First arcuate member 2902 is rotatably coupled to second arcuate

member 2904 at hinge 2906. The position of connection clamp 2802 along tube assembly 104 can be adjusted by raising the handle 2910 to cause first arcuate member 2902 to rotate away from second arcuate member 2904, increasing the size of opening 2912. Once connection clamp 2802 has been positioned, handle 2910 can be closed so that connection clamp 2802 clamps onto tube assembly 104.

[0084] Fig. 30 depicts a rear view of connection clamp 2804. First arcuate member 2902 comprises hinge section 3002 which is complimentary to hinge section 3004 of second arcuate member 2904. A pin placed through a channel in first arcuate member 2902 and second arcuate member 2904 allows first arcuate member 2902 to rotate about hinge 2906 with respect to second arcuate member 2904.

[0085] Fig. 31 depicts an interior view of first arcuate member 2902. First arcuate member 2902 further comprises first arm 3102 and second arm 3104. A pin placed through first arm 3102, latch 2908, and second arm 3104 allows latch 2908 to rotate between first arm 3102 and second arm 3104. Ribs 3106 have a curvature approximately the same or slightly smaller than the tube on which connection clamp 2804 is placed, which in this example is tube assembly 104. Recess 3108 and protrusion 3110 are located between ribs 3106. Protrusion 3110 is pressed against tube assembly 104 when connection clamp 2804 is in the closed position and helps to prevent it from sliding.

[0086] Fig. 32 depicts an interior view of second arcuate member 2904. Second arcuate member 2904 further comprises first arm 3202 and second arm 3204. A pin placed through first arm 3202, handle 2910, and second arm 3204 allows handle 2910 to rotate between first arm 3202 and second arm 3202. Ribs 3206 have a curvature approximately the same or slightly smaller than the tube on which connection clamp 2804 is placed, which in this example is tube assembly 104. Recess 3208 and protrusion 3210 are located between ribs 3206. Protrusion 3210 is pressed against tube assembly 104 when connection clamp 2804 is in the closed position and helps to prevent it from sliding. As should be obvious from Figs. 31 and 32, first arcuate member 2902 and second arcuate member 2904 are complimentary mirror images of each other.

[0087] Fig. 33 depicts connection clamp 2804 in an open configuration. As shown, lifting handle 2910 allows first arcuate member 2902 and second arcuate member 2904 to open about joint 2906, allowing for adjustment of connection clamp 2804 along the length of adjustable shoring beam 100.

5 [0088] Figs. 34-36 depict bracket 2802 in isolation. Bracket 2802 is preferably formed from steel. Bracket 2802 generally comprises bracket body 3402 and receiving structure 3404. In the depicted embodiment, receiving structure 3404 is rectangular in shape, having a length and a width to accommodate E-track hook such as a first hook assembly 106 or a second hook assembly 108 placed therein as will be
10 described later. However, it should be obvious that the shape and/or size of receiving structure can be modified to be round, square, etc., to accommodate other shaped mating structures.

[0089] Further, in the depicted embodiment, there is a receiving structure 3404 only on a first side of bracket 2802. However, receiving structure 3404 can be
15 added to any location around the exterior of bracket body 3402. In other embodiments, two or more receiving structures 3404 may be present on bracket 2802, such as on opposing sides (e.g., top and bottom, left and right). In another embodiment, four receiving structures 3404 are present around bracket 2802 which are positioned at a top, bottom, left side, and right side of bracket 2802. Different
20 types of receiving structures 3404 may be coupled to different sides of the same bracket 2802.

[0090] Openings 3408 preferably have a diameter the same as or greater than a diameter of tube assembly 104 and/or rod assembly 102 so that bracket 2802 can be positioned along an adjustable shoring beam 100 when tube assembly 104 or rod
25 assembly 102 is placed through openings 3408. In a preferred embodiment, openings 3408 have a same diameter as openings 2912 of connection clamp 2804 as depicted in Fig. 28

[0091] Bracket body 3402 generally comprises end members 3406 having openings 3408, with end members 3406 being parallel to each other. Two or more
30 rectangular connecting beams 3410 connect the first end member 3406 to the second end member 3406 to form bracket body 3402. In the depicted embodiment, three

connecting beams 3410 are present at a top side, a left side, and a right side of bracket 2802. Receiving structure 3404 is coupled to an exterior surface of one or more of the connecting beams 3410. A spacing between at least to connecting beams 3410 around the periphery of end members 3406 must be large enough so that handle 2910 can be
5 opened and closed as needed.

[0092] Preferably, connecting beams 3410 have a same length as that of receiving structure 3404. However, it should be apparent that connecting beams 3410 may be longer and/or shorter than receiving structure 3404.

[0093] Bracket body 3402 is sized so that connection clamp 2804 can be
10 nested within bracket body 3402 with openings 2912 and 3408 in alignment as depicted in Fig. 28. After connection clamp 2804 has been placed/nested within bracket body 3402, it can then be slide over adjustable shoring beam 100 and secured in place by actuating handle 2910. Bracket 2802 can be freely rotated around connection clamp 2804. However, in some embodiments, bracket body 3402 may
15 comprise inward projecting structures and/or connection clamp 2804 may comprise outward projecting structures which prevent rotation of bracket 2802 around connection clamp 2804, fixing their positions relative to each other.

[0094] Figs. 37-39 depict how connection assembly 2800 can be used to connect a first adjustable shoring beam 100 to a second adjustable shoring beam 100.
20 As already described, connection assembly is first adjusted along the length of the first adjustable shoring beam 100 and then is fixed in position as depicted in Fig. 38. A first hook assembly 106 or second hook assembly 108 of a second adjustable shoring beam 100 is then placed in receiving structure 3404 as depicted in Fig. 37 until a bottom of hook section 904 contacts a top surface of connecting beam 3410 as
25 depicted in Fig. 39. The other end of the second adjustable shoring beam 100 can then be placed in another connection assembly 2800 of a third adjustable shoring beam 100 (not shown).

[0095] Figs. 40-44 depict the steps utilized to couple a first adjustable shoring beam 4002 to a second adjustable shoring beam 4004. Handle 2910 of connection
30 clamp 2804 is opened so that connection clamp 2804 can be slid along adjustable shoring beam 4004 as depicted in Fig. 30. Connection clamp 2804 is then inserted

into bracket 2802 as depicted in Fig. 41 to form connection assembly 2800.

Connection assembly 2800 is positioned over second adjustable shoring beam 4004 as depicted in Fig. 42. First hook assembly 106 of first adjustable shoring beam 4002 is then inserted into receiving structure 3404 of connection assembly 2800 as depicted in
5 Fig. 43. Handle 2910 is then locked to secure movement of connection assembly 2800 as depicted in Fig. 44.

[0096] Fig. 45 depicts a current method used to secure freight and cargo to a movable platform 4500, such as those disclosed in U.S. Patent No. 10,279,955, issued May 7, 2019. Straps 4502 are used to secure the ends of the freight on the movable
10 platform 4500. These straps 4502 take a long time to secure as each end must be secured across the movable platform 4500 as depicted in Fig.45. Further, straps 4502 may not always be available at every cross-dock location which movable platform 4500 traverses.

[0097] Fig. 46 depicts how adjustable shoring beams 100 having connection
15 structures 2800 installed can alleviate this problem. Adjustable shoring beams 100 are first used on the vertical posts of the movable platform 4500 to secure the freight along the length of movable platform 4500 as depicted in Fig. 10A, for example. Because each adjustable shoring beam 100 already has a connection assembly 2800, one or more adjustable shoring beams 100 can then be coupled to opposing
20 connection assemblies 2800 on opposing adjustable shoring beams 100 as depicted in Fig. 45. Connection assembly 2800 also allows an adjustable shoring beam 100 to be installed horizontally and/or vertically between to other adjustable shoring beams 100.

[0098] The design of the adjustable shoring beams 100 discussed herein are designed so that gravity causes the perpendicular connection side of bracket 2802 to
25 naturally fall and rotate downward, maintaining a low profile. The coupling between connection assembly 2800 and adjustable shoring beam 100 is able to maintain a positive connection during transit and exceeds trucking securement standards. Further, because the length of adjustable shoring beam 100 can be quickly adjusted and added to vertical posts or used to bridle other adjustable shoring beams 100, there
30 is time saving compared to using straps 4502. The handle 2910 of connection bracket 2804 can also easily be manipulated by a user's thumb, even with gloves on.

[0099] While the present invention has been described with respect to what is presently considered to be the preferred embodiments, it is to be understood that the invention is not limited to the disclosed embodiments. To the contrary, the invention is intended to cover various modifications and equivalent arrangements included
5 within the spirit and scope of the appended claims. The scope of the following claims is to be accorded the broadest interpretation so as to encompass all such modifications and equivalent structures and functions.

CLAIMS

1. An adjustable shoring beam comprising:
 - a rod assembly;
 - a tube assembly,
 - wherein the rod assembly is slidably received within the tube assembly;
 - a first hook assembly coupled to a first end of the rod assembly; and
 - a second hook assembly coupled to a first end of the tube assembly,
 - wherein a centerline of the first hook assembly is offset from a centerline of the rod assembly,
 - wherein a centerline of the second hook assembly is offset from a centerline of the tube assembly,
 - wherein the first hook assembly comprises a securement plate and a securement hook coupled to the securement plate
 - wherein the securement plate has a rectangular cutout extending from a center of a top of the securement plate towards a center of the securement plate, and
 - wherein the securement hook comprises:
 - a securement section,
 - and a hook section,
 - wherein the securement section is coupled to the hook section to form an L-shaped hook, and
 - wherein a height of the securement section is equal to a height of the rectangular cutout, and
 - wherein a width of the securement section is equal to a thickness of the rectangular cutout.

2. The adjustable shoring beam according to claim 1, wherein a center of the rod assembly is offset 0.5-0.6” from a top of the securement plate and the center of the first hook assembly is offset 0.5-0.6” from a left side of the securement plate.

3. The adjustable shoring beam according to claim 1 or claim 2, wherein the first hook assembly and the second hook assembly are configured to mate with corresponding E-track slots.

4. The adjustable shoring beam according to any one of claims 1-3, wherein the first hook assembly is rotated 90° with respect to the second hook assembly.

5. The adjustable shoring beam according to any one of claims 1-4, further comprising:

a longitudinal groove in the tube assembly in a same direction as a central axis of the tube assembly;

an opening in the rod assembly; and

a pin placed through the longitudinal groove into the opening to prevent separation of the rod assembly and the tube assembly.

6. The adjustable shoring beam according to any one of claims 1-5, wherein the securement plate has a rectangular shape with chamfered edges.

7. The adjustable shoring beam according to claim 6,
wherein a radius of curvature of the chamfered edges is 0.25",
wherein the securement plate has a height of approximately 2.75",
wherein the securement plate has a width of approximately 2.25", and
wherein the securement plate has a thickness of 0.35-0.45".

8. The adjustable shoring beam according to any one of claims 1-7, wherein the securement section and the hook section are formed from a unitary body.

9. The adjustable shoring beam according to any one of claims 1-8, wherein an end of the securement section is coupled to the securement plate such that a rear edge of the securement hook is flush with a surface of the securement plate and a top of the securement hook is flush with a top edge of the securement plate.

10. The adjustable shoring beam according to claim 9, wherein the end of the securement section is welded to the securement plate to form the first hook assembly.

11. A hook assembly for use with an adjustable shoring beam, the hook assembly comprising:

a securement plate,

wherein the securement plate has a rectangular shape; and

a hook having an L-shape extending from a front surface of the securement plate,

wherein the hook comprises:

an extension section; and

a hook section perpendicular to the extension section,

wherein a top surface of the extension section is flush with a top surface of the securement plate.

12. The hook assembly according to claim 11, wherein a portion of the extension section is situated in a cutout extending from a top surface of the securement plate towards a center of the securement plate.

13. The hook assembly according to claim 12,

wherein the securement plate has a width of approximately 2.25",

wherein the securement plate has a thickness of 0.35-0.45",

wherein the extension section has a width of approximately 1.5",

wherein the extension section has a height of approximately 0.75",

wherein the hook section has a height of approximately 1.5", and

wherein the hook section has a width of approximately 0.375".

14. The hook assembly according to any one of claims 11-13, further comprising:

a connection rod coupled to a rear surface of the extension section,

wherein a centerline of the connection rod is offset from a centerline of the securement plate.

15. The hook assembly according to claim 14, wherein the connection rod is solid.

16. The hook assembly according to claim 14, wherein the connection rod comprises a first through hole and a second through hole spaced apart from the first through hole.

17. The hook assembly according to claim 16, wherein a center longitudinal axis of the first through hole is not aligned with a center longitudinal axis of the second through hole.

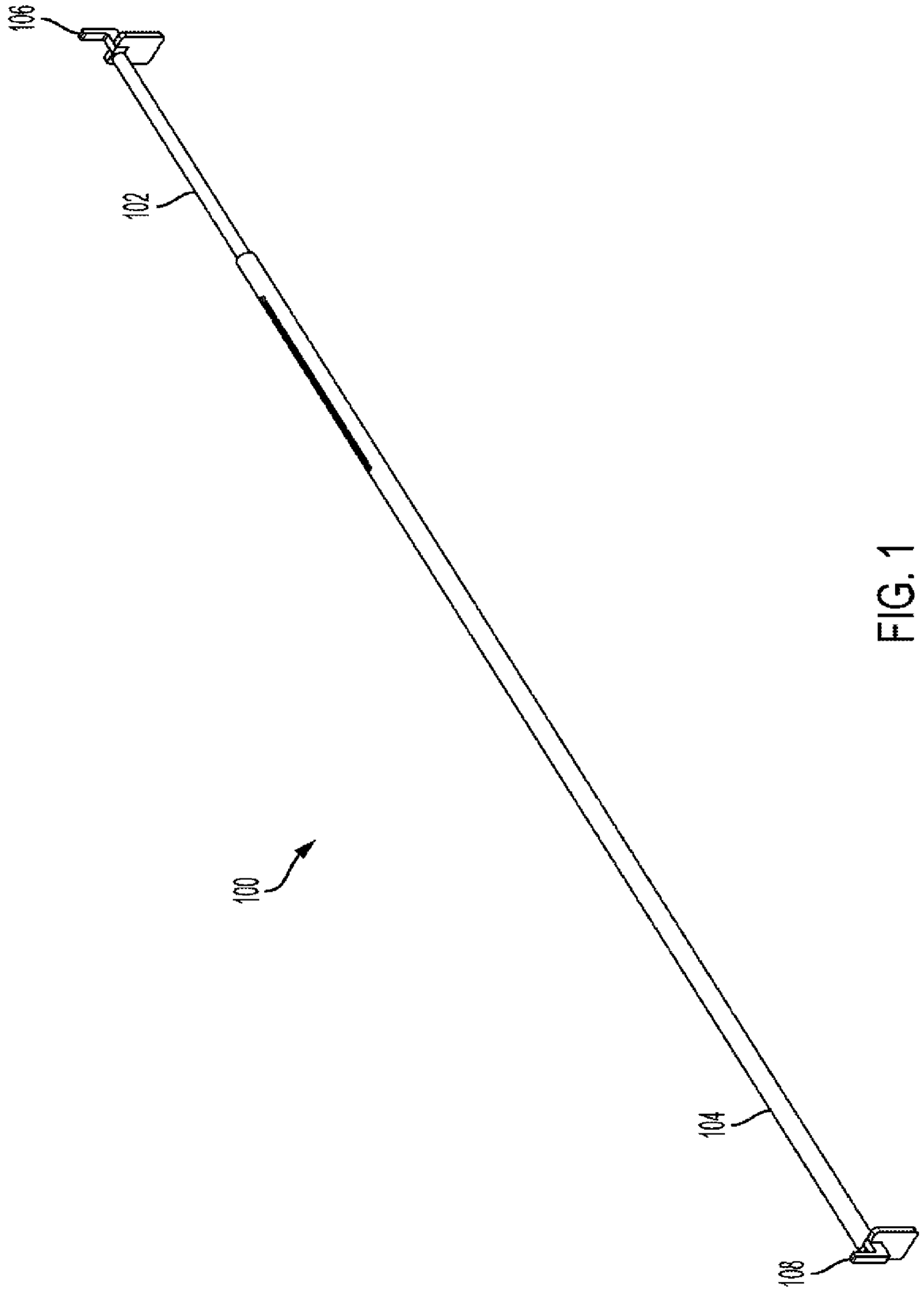

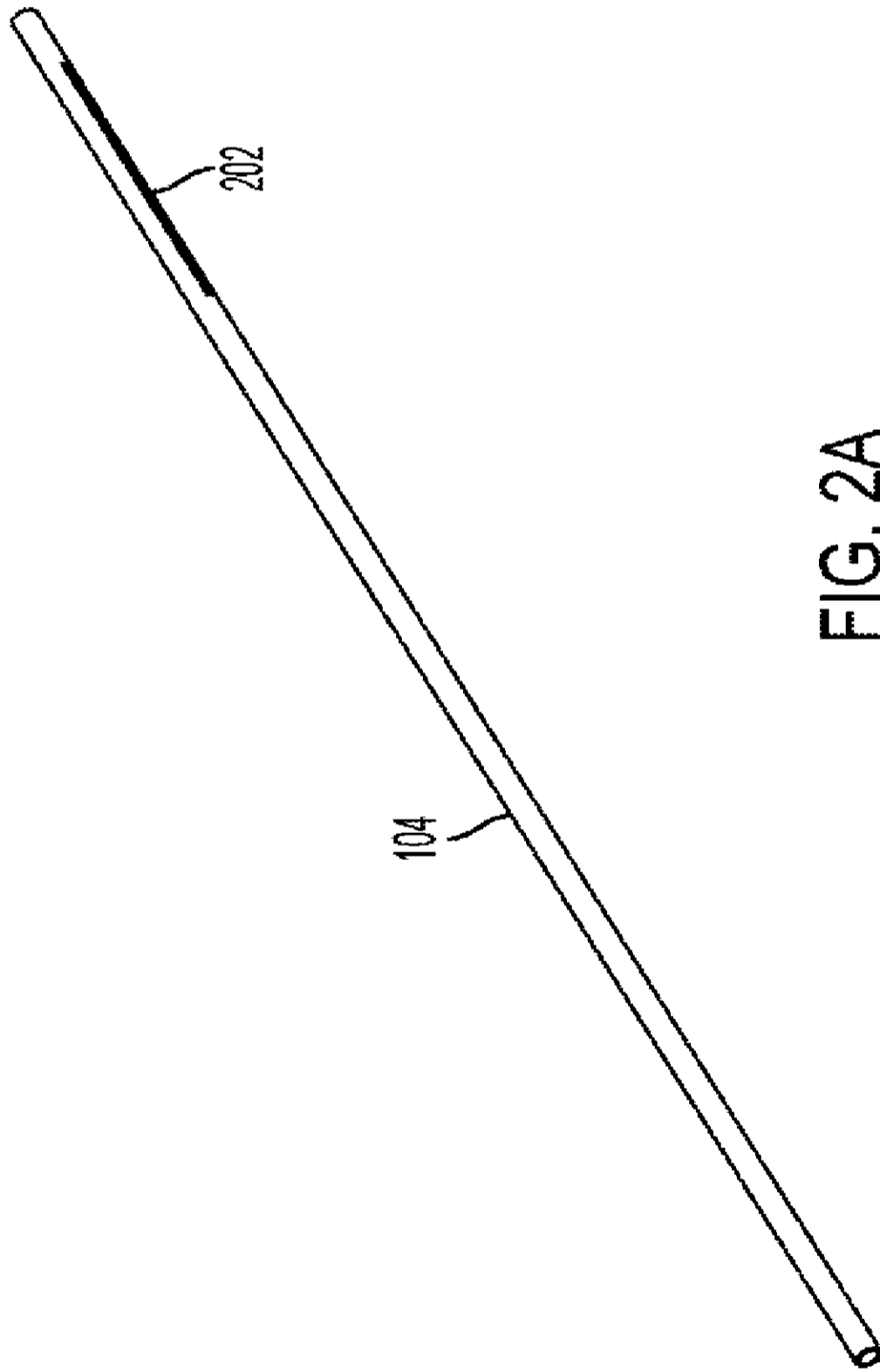

FIG. 2A

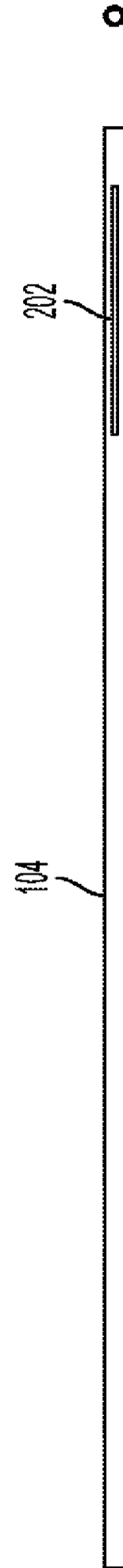

FIG. 2B

FIG. 2C

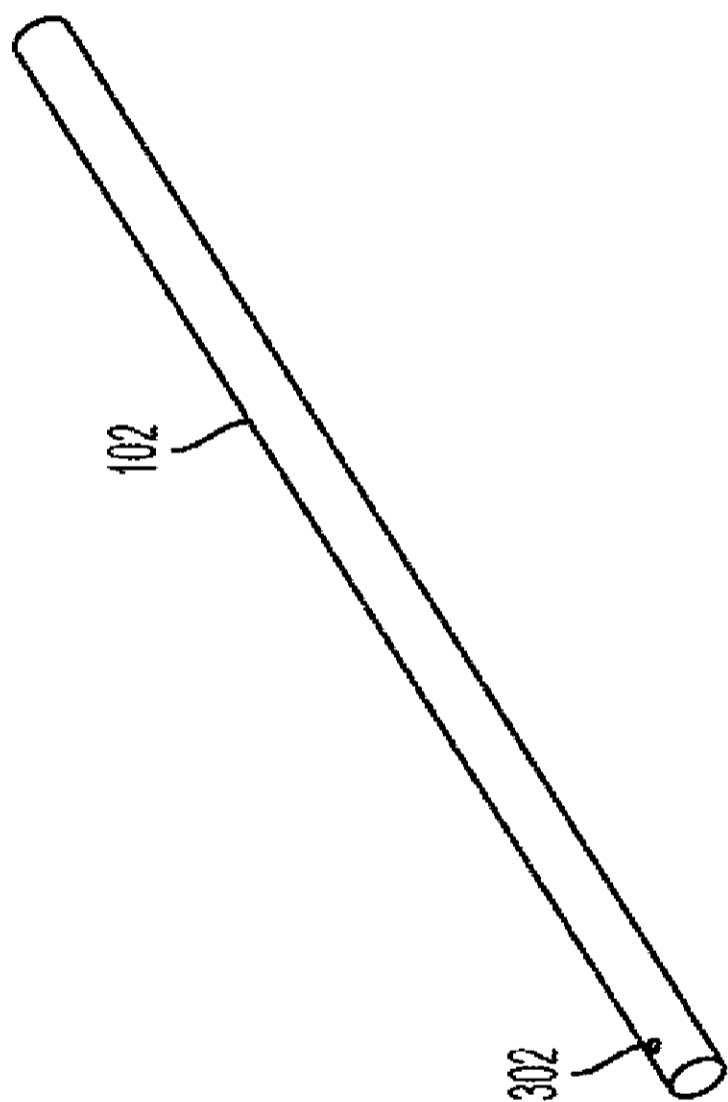

FIG. 3A

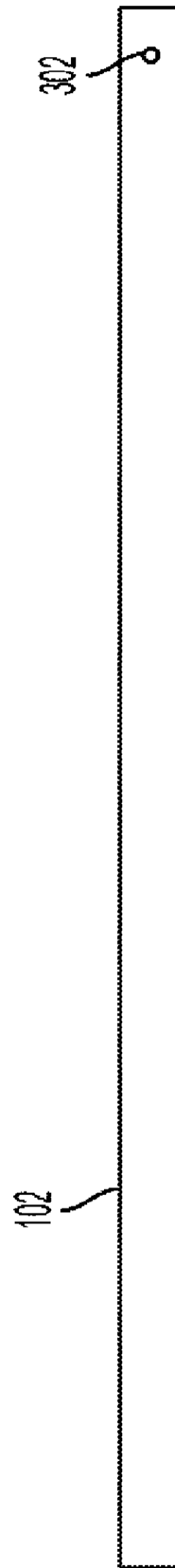

FIG. 3B

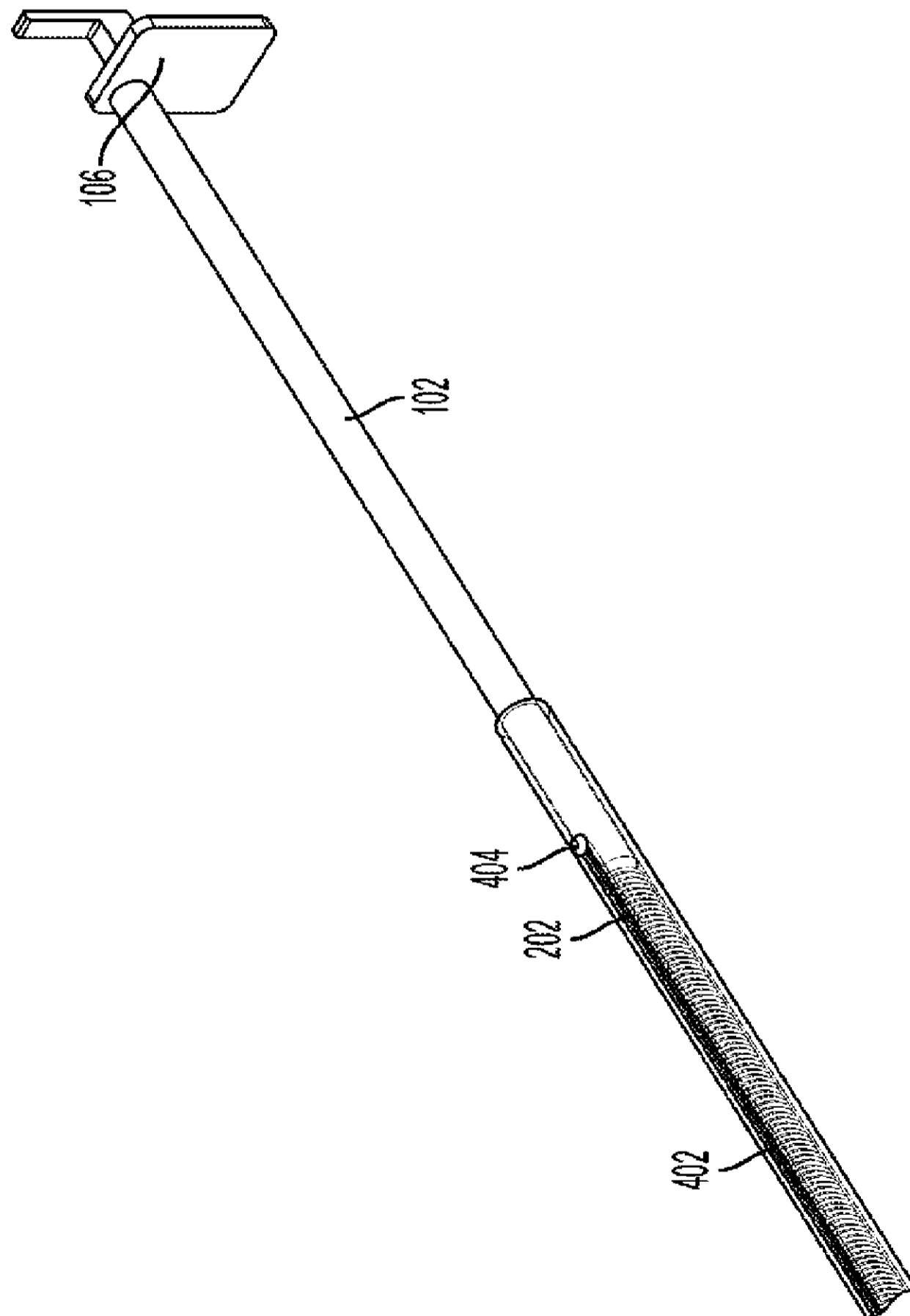

FIG. 4

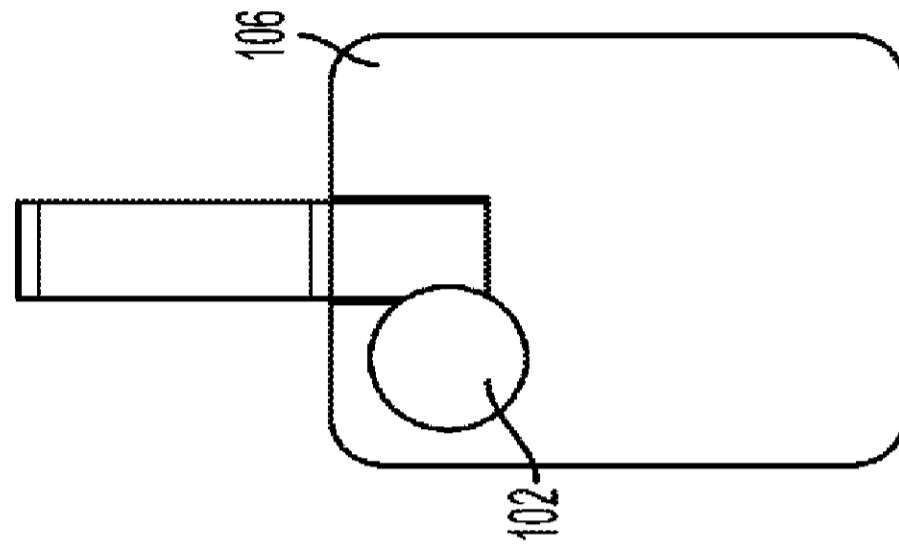

FIG. 5B

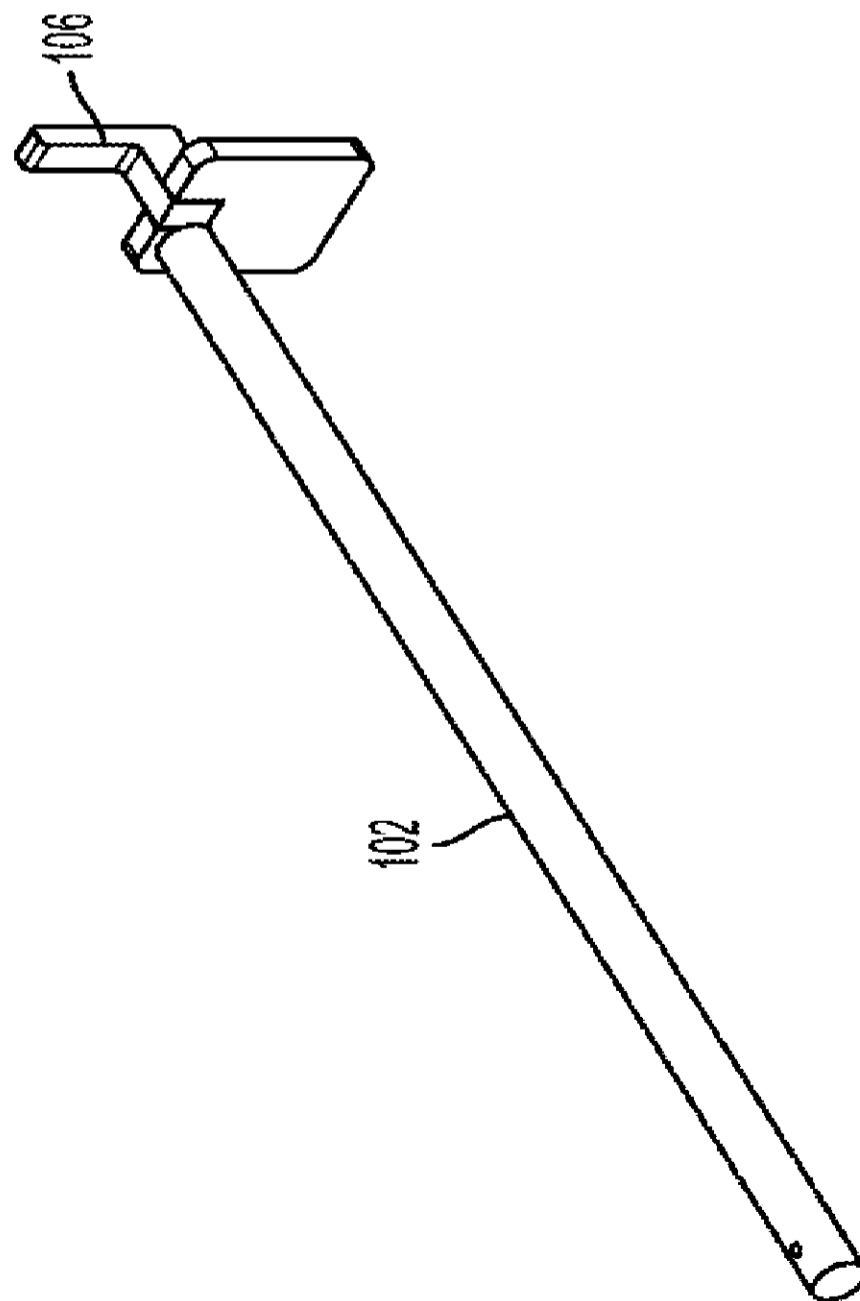

FIG. 5A

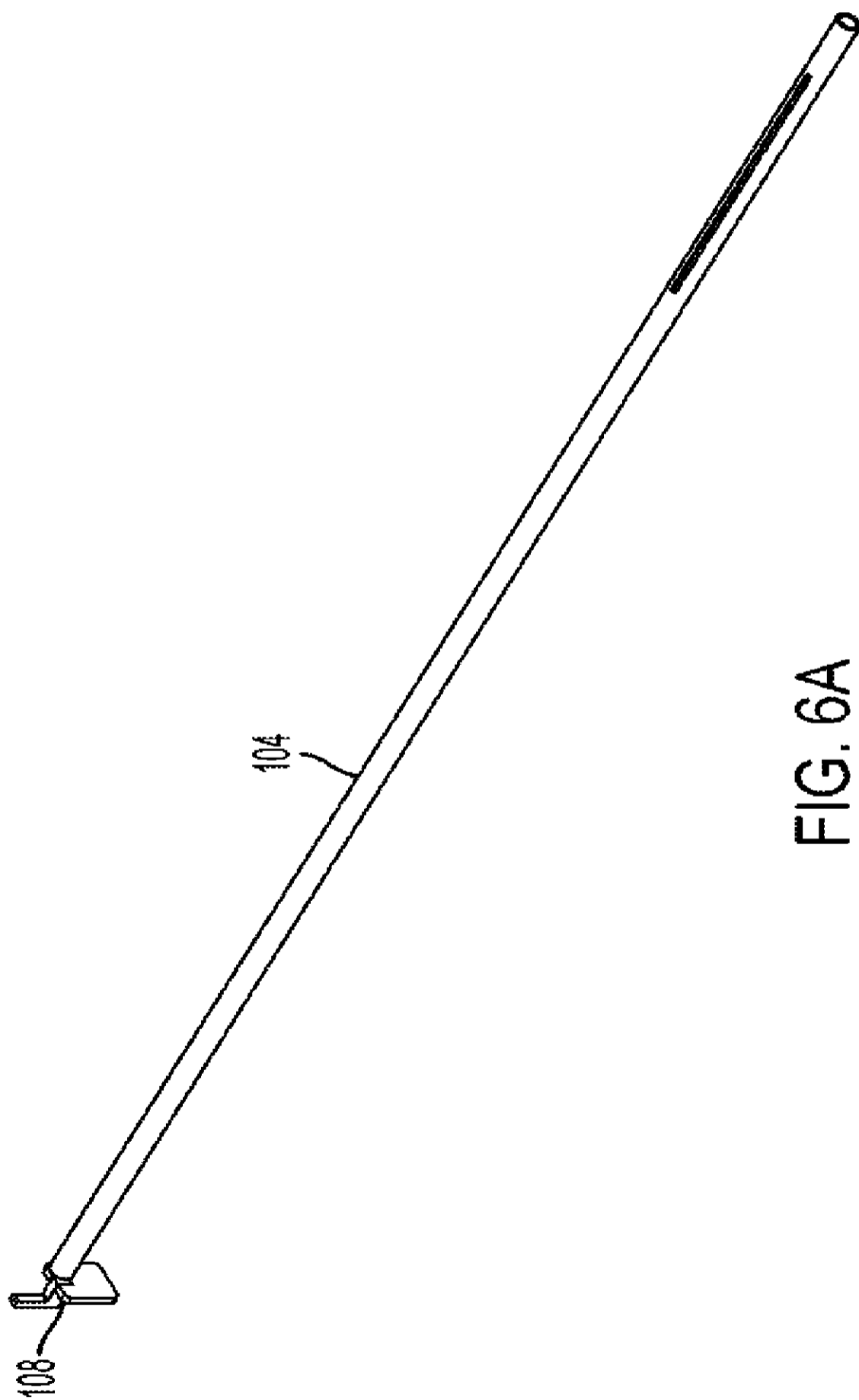

FIG. 6A

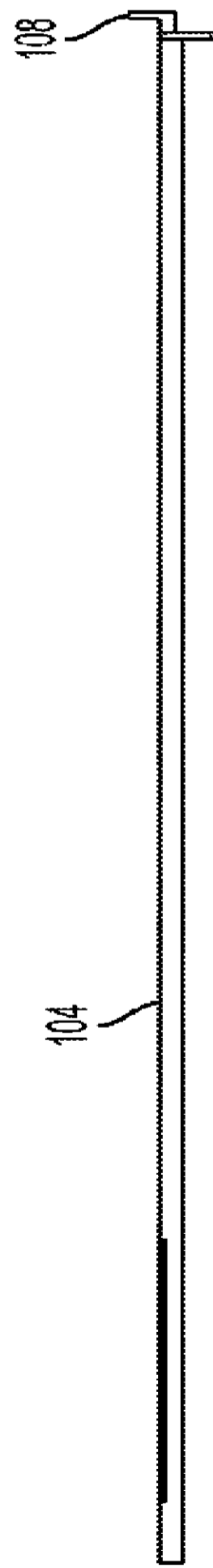

FIG. 6B

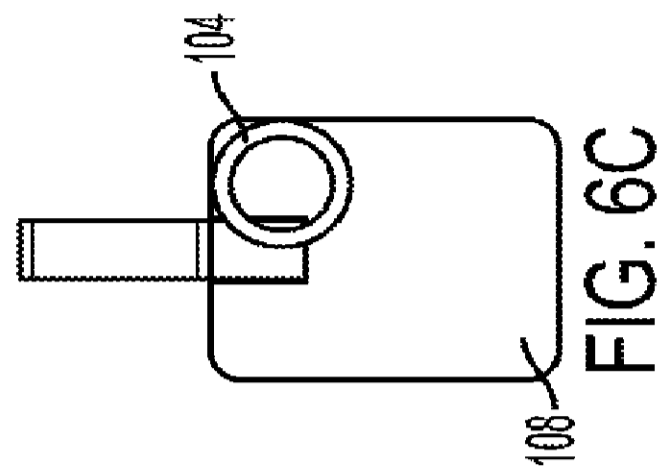

FIG. 6C

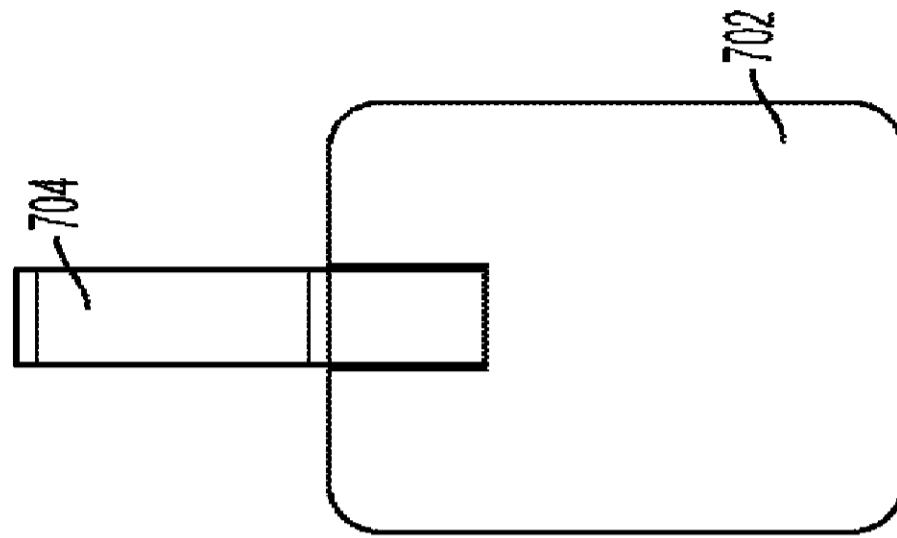

FIG. 7C

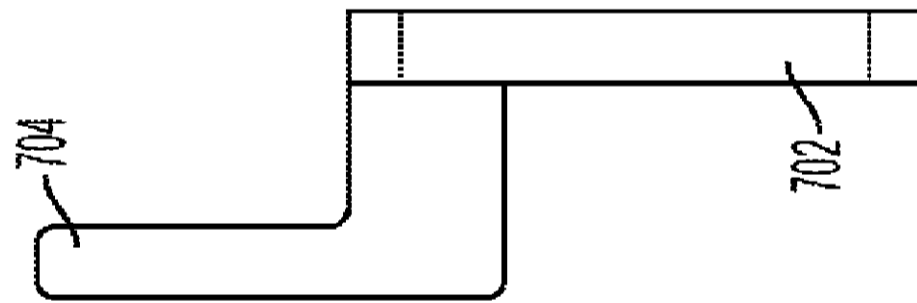

FIG. 7B

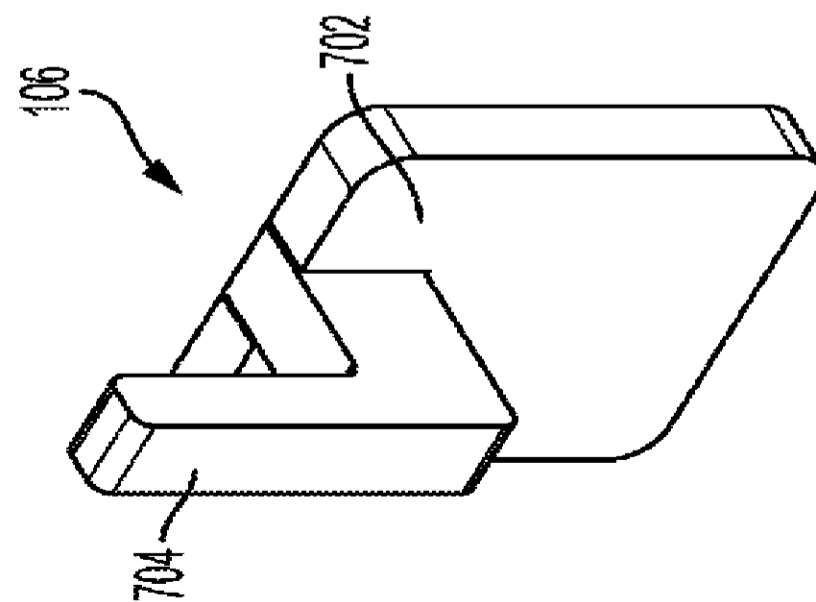

FIG. 7A

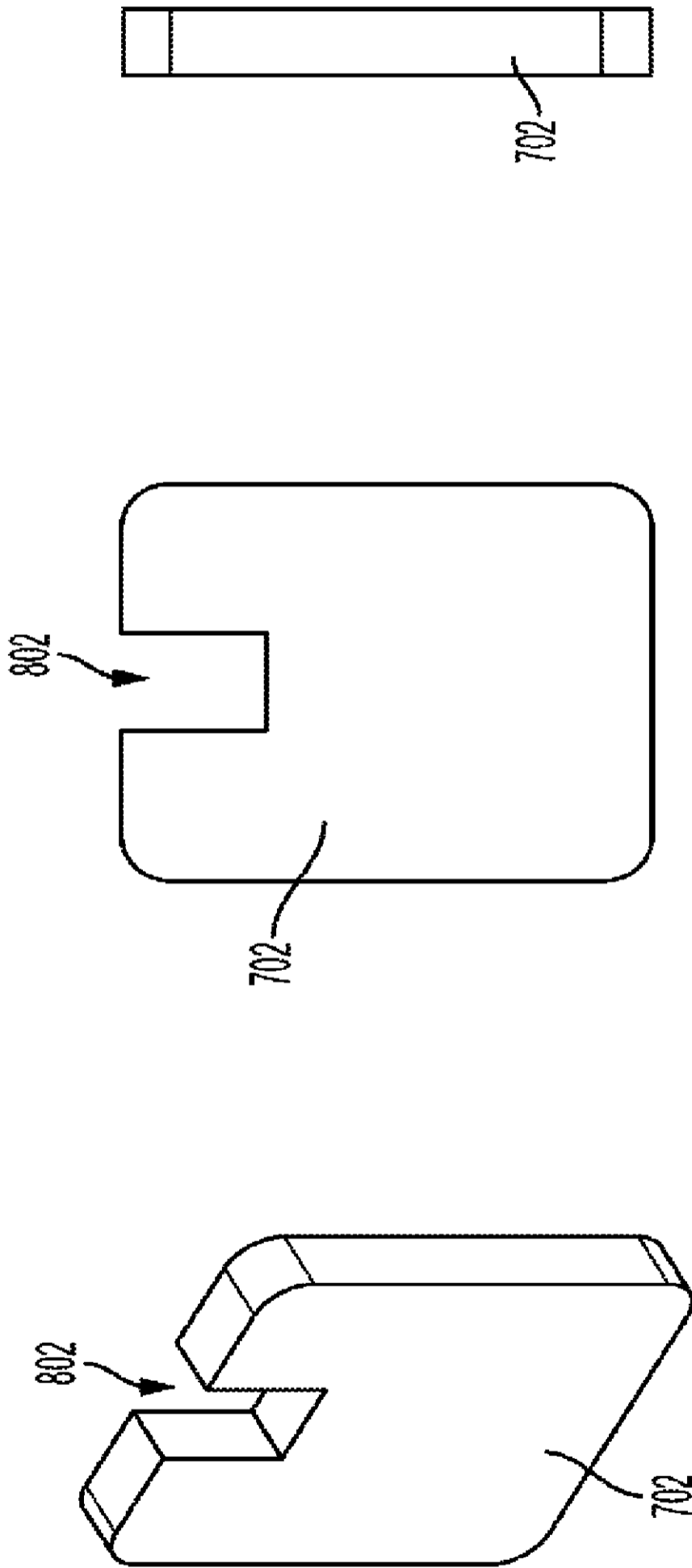

FIG. 8C

FIG. 8B

FIG. 8A

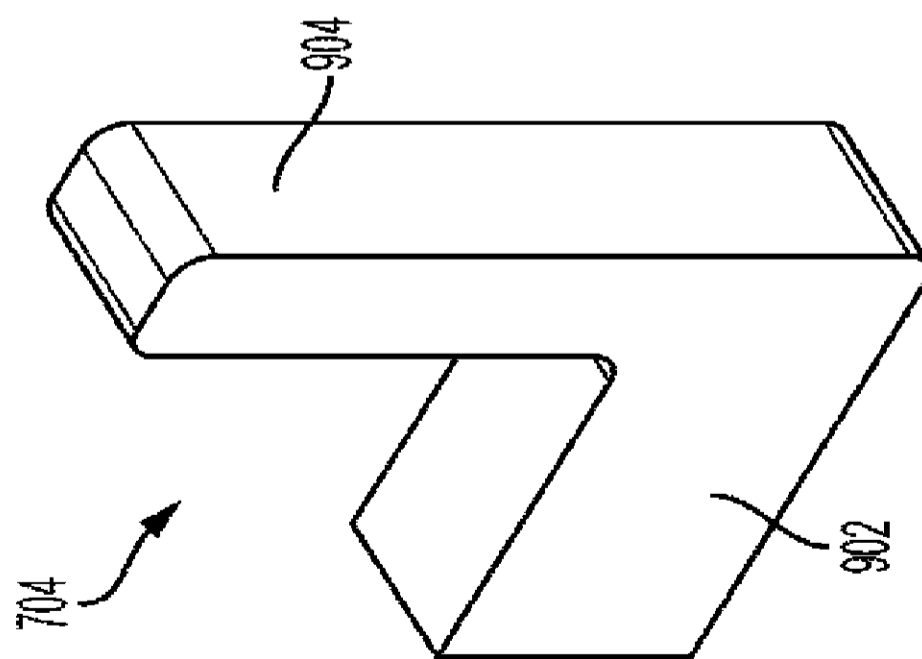

FIG. 9A

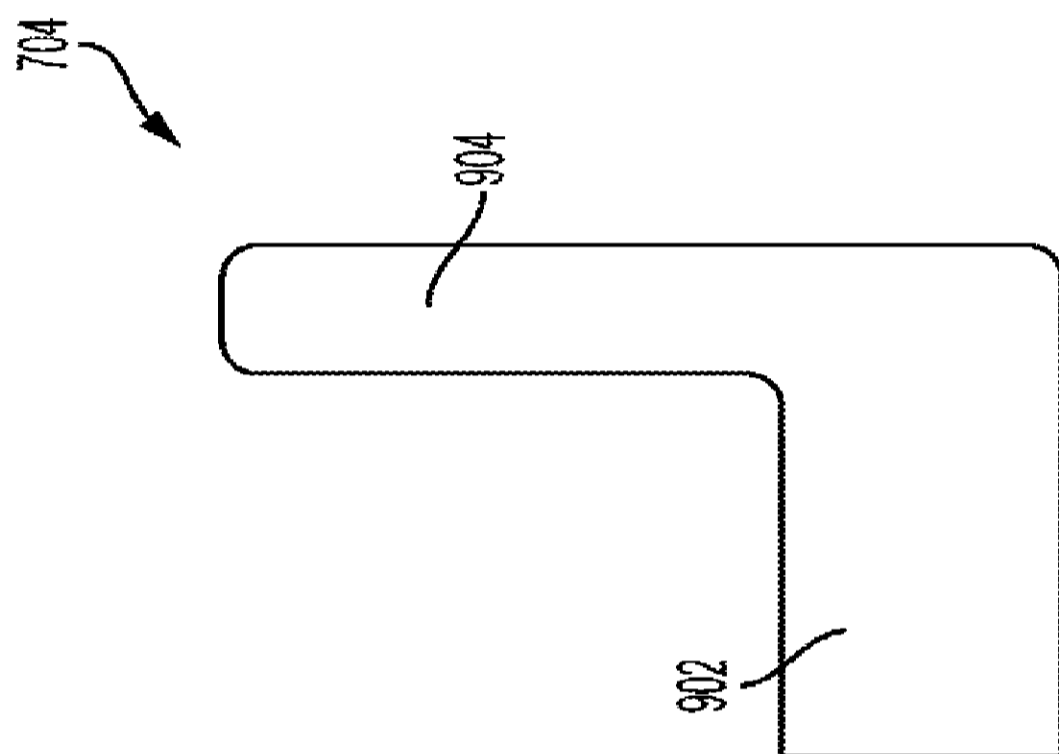

FIG. 9B

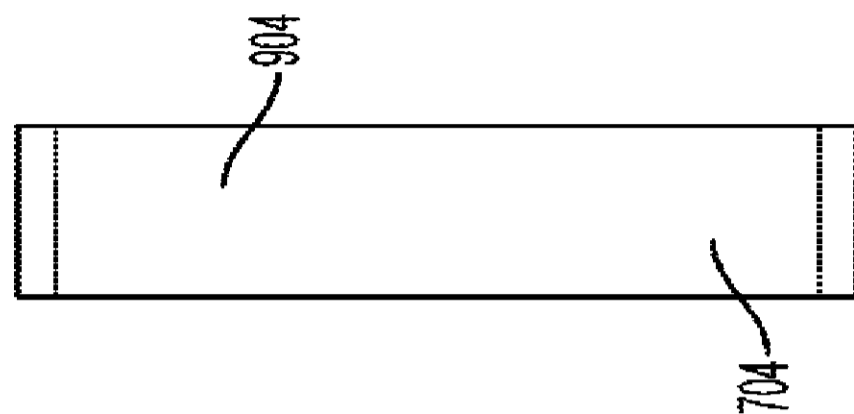

FIG. 9C

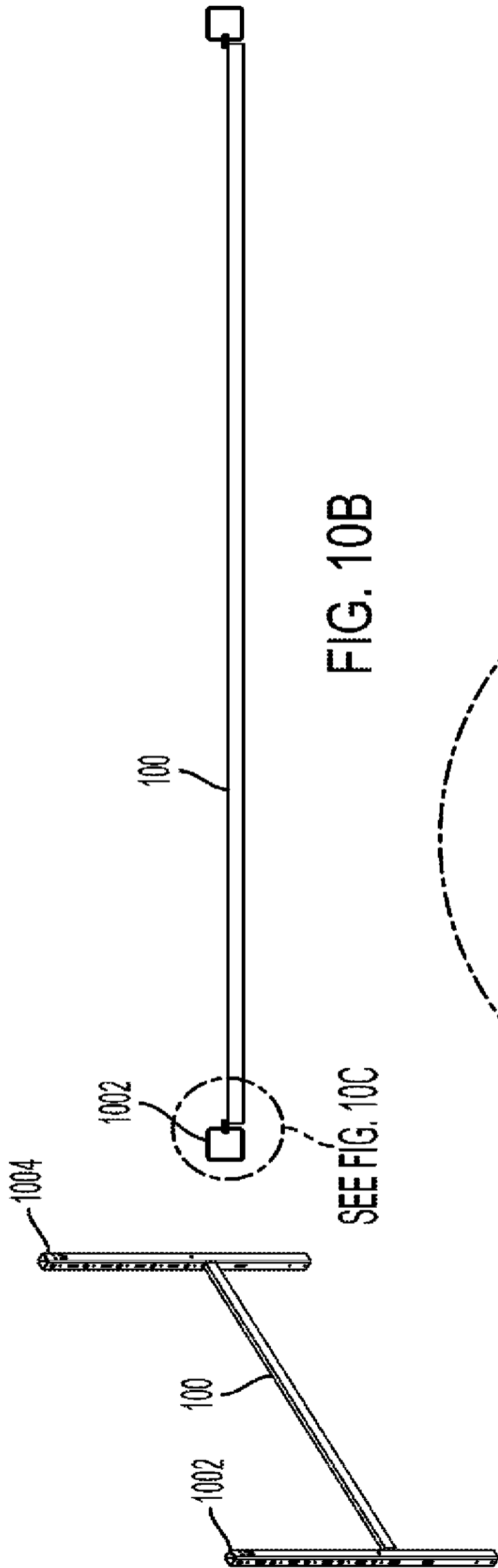

FIG. 10A

FIG. 10B

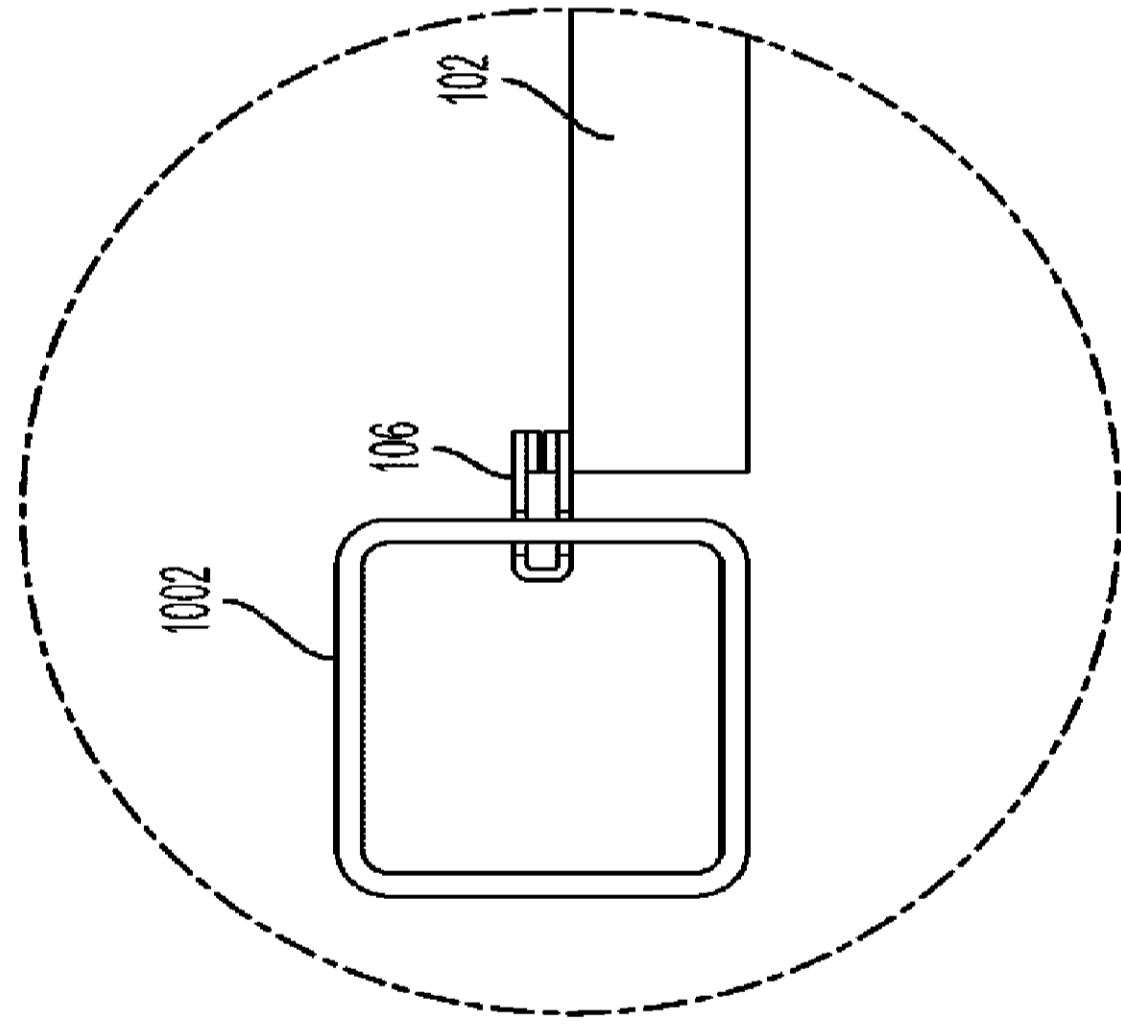

FIG. 10C

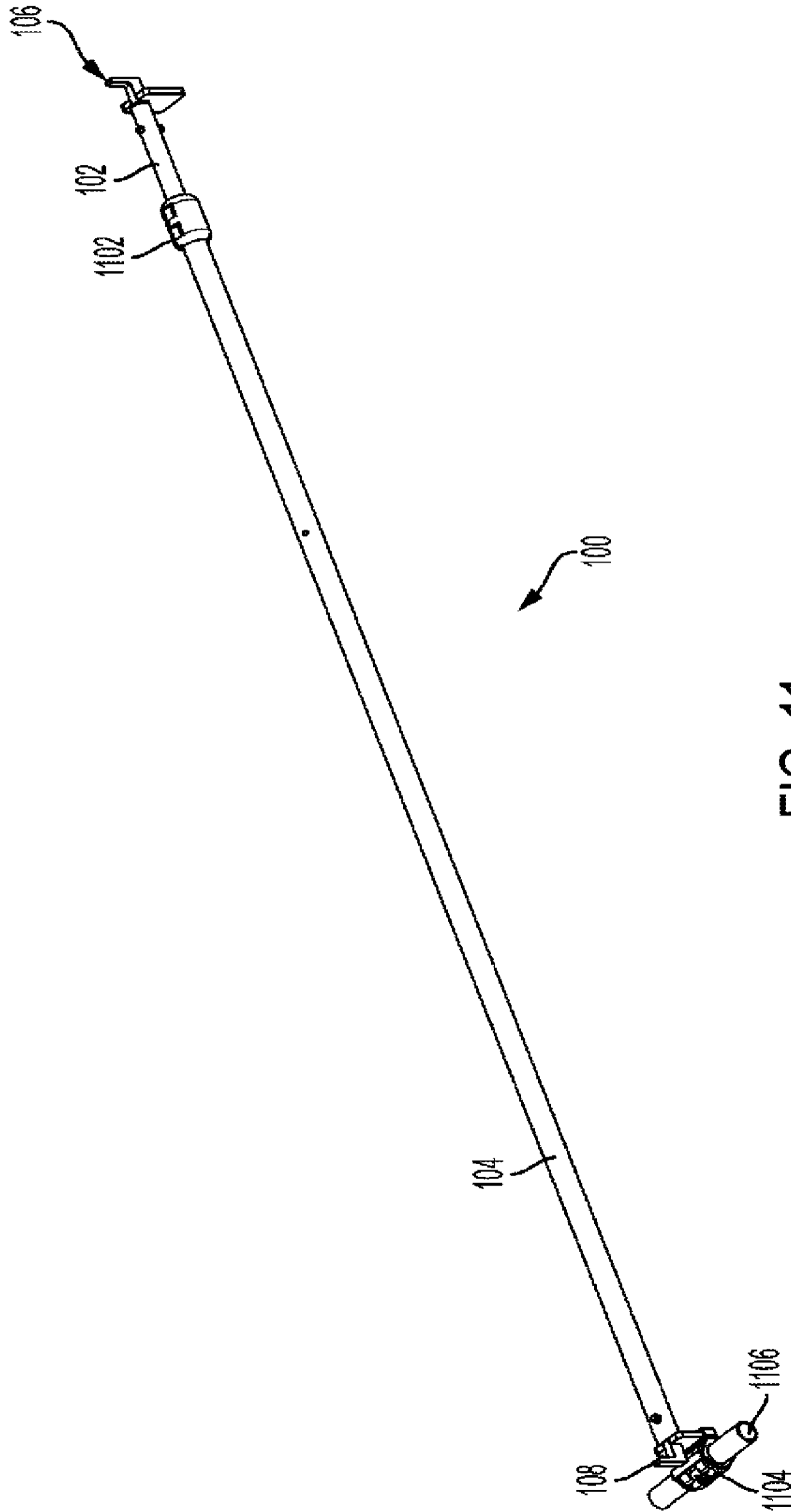

FIG. 11

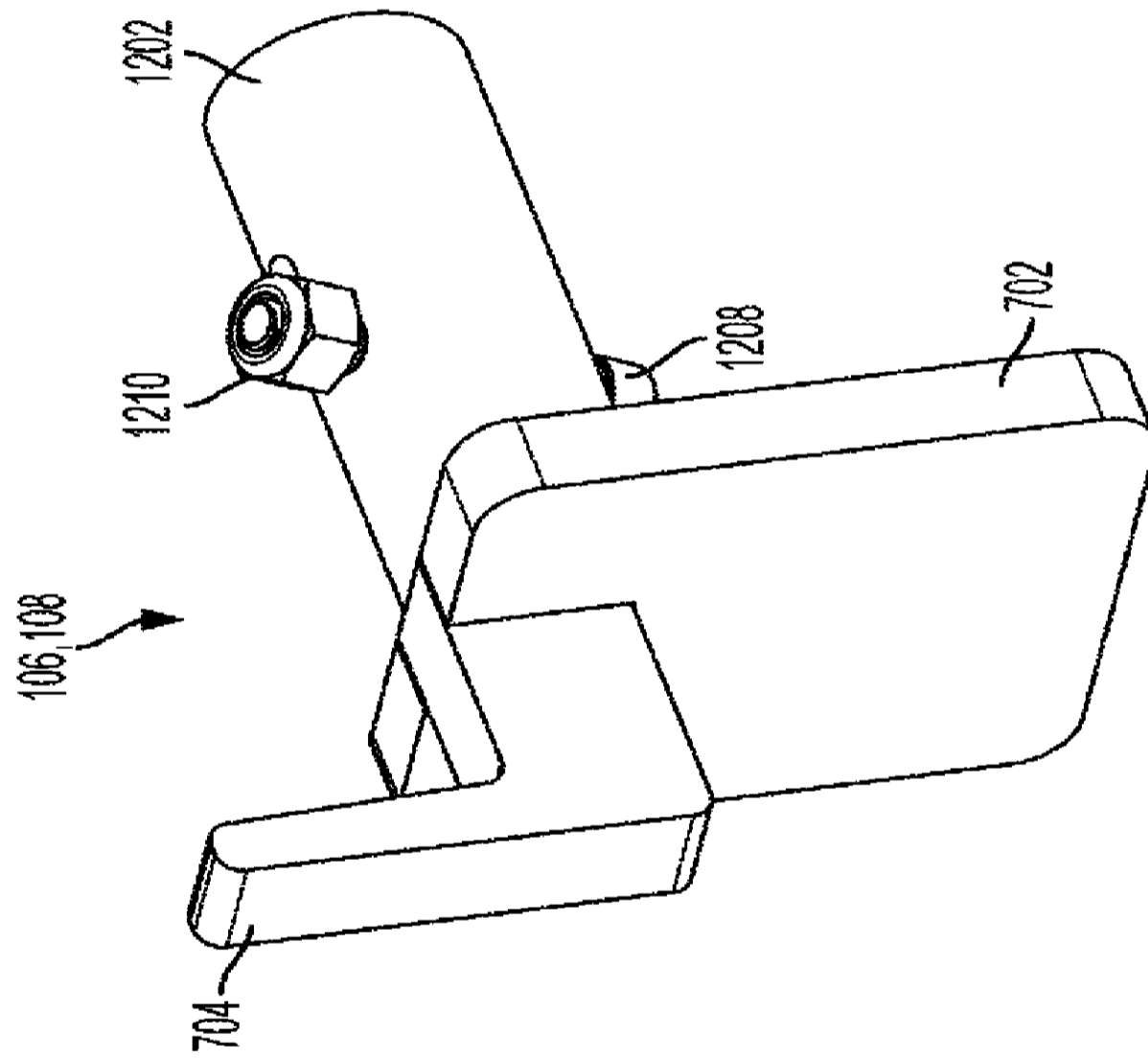

FIG. 12

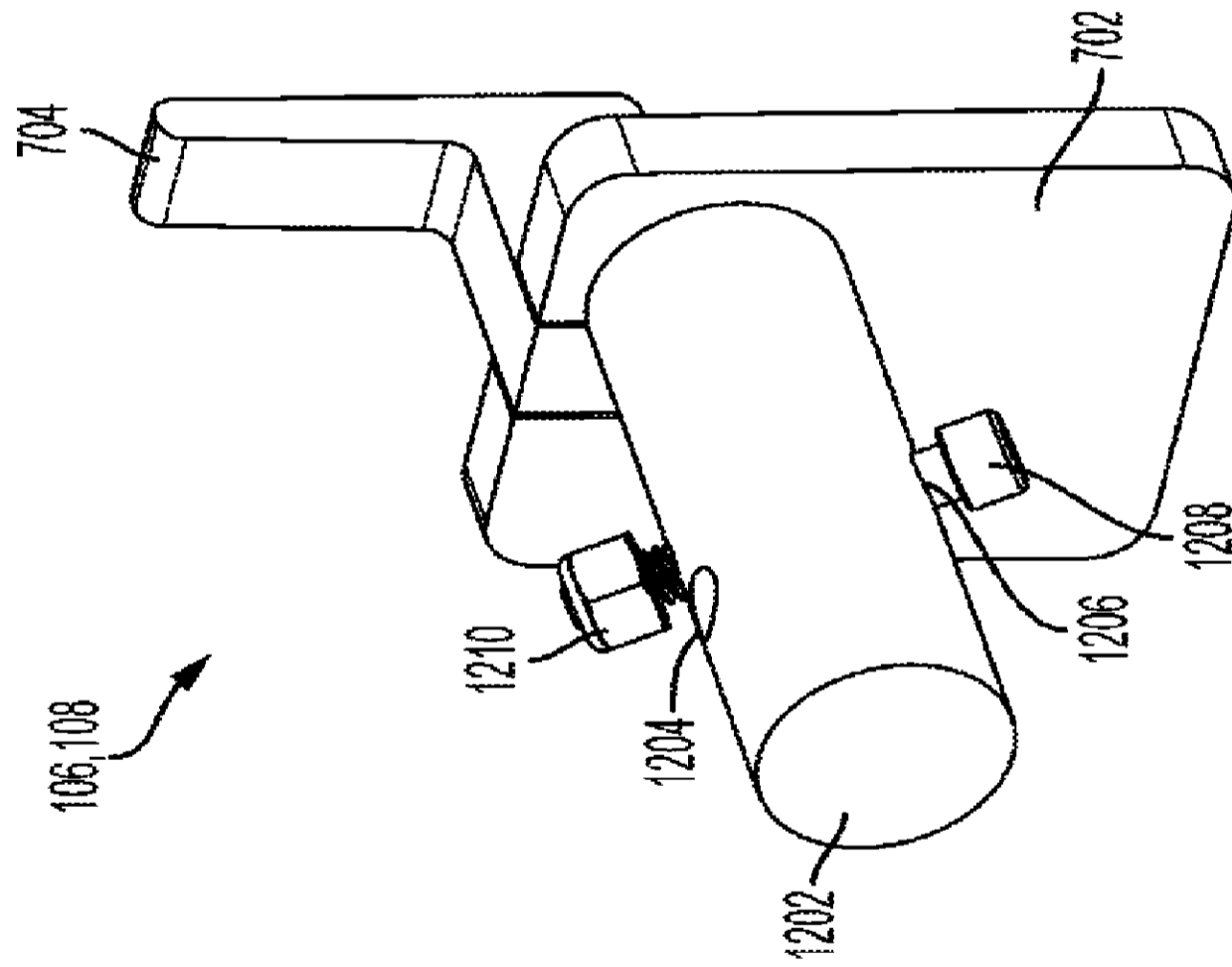

FIG. 13

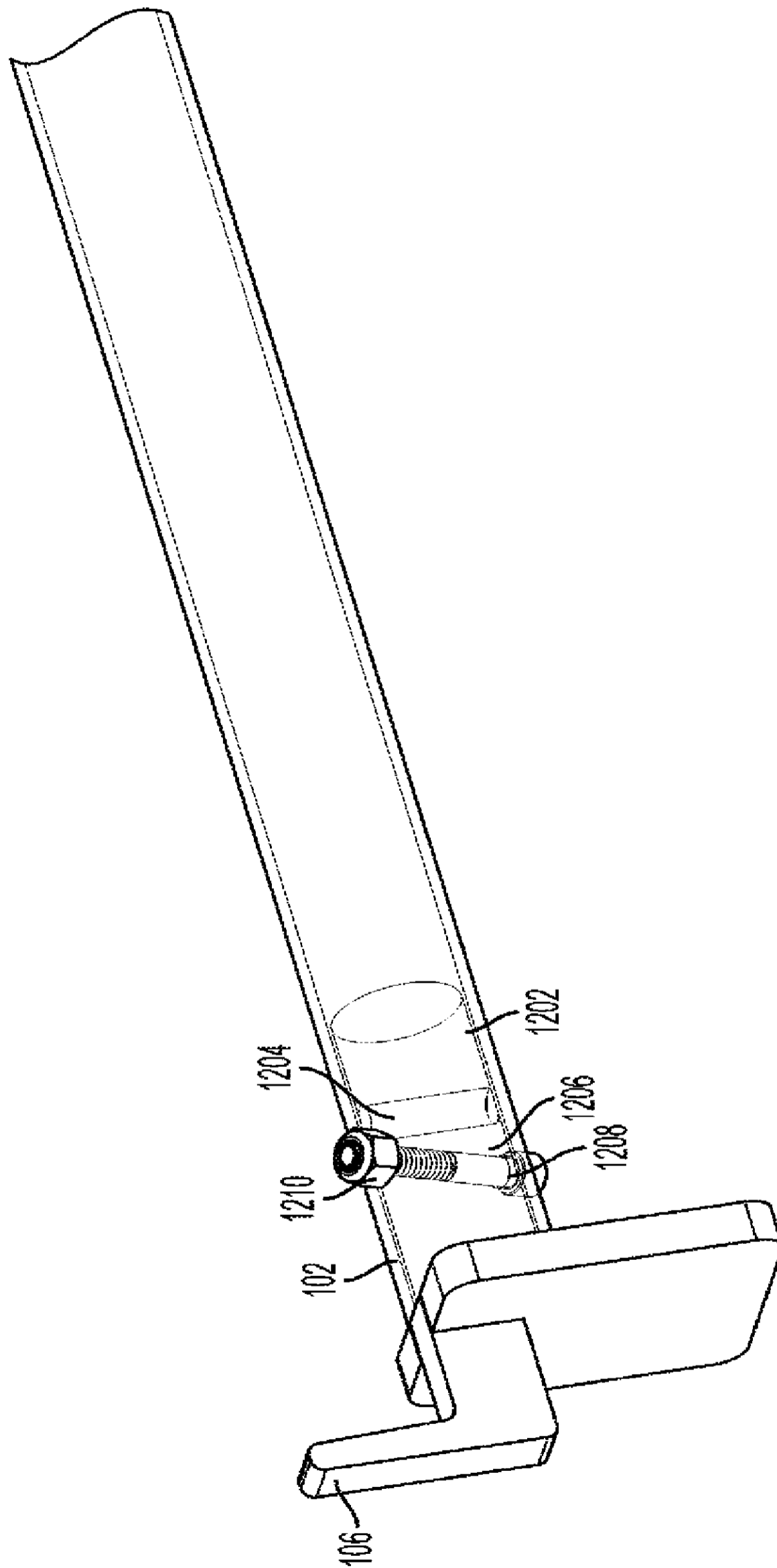

FIG. 14

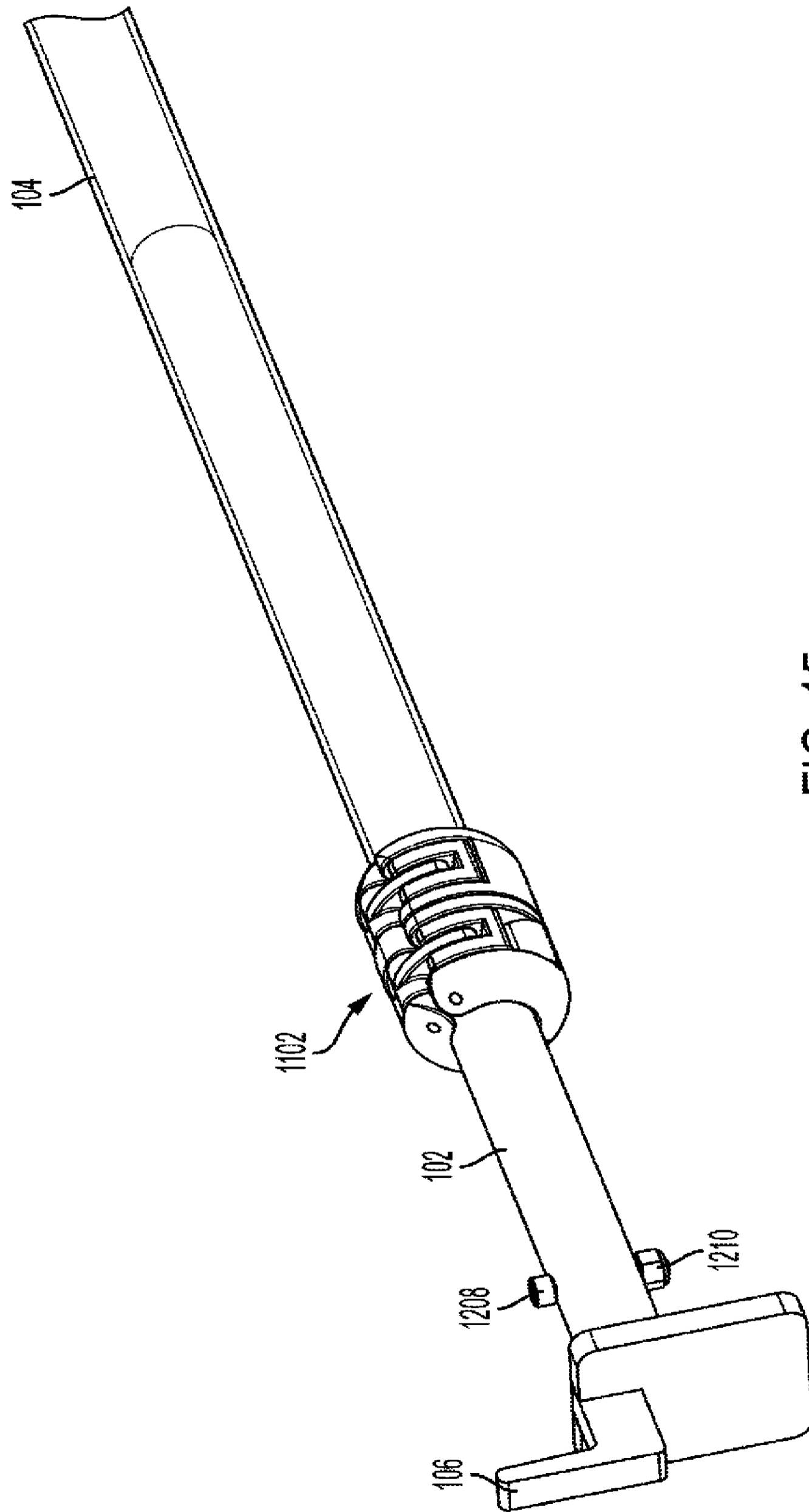

FIG. 15

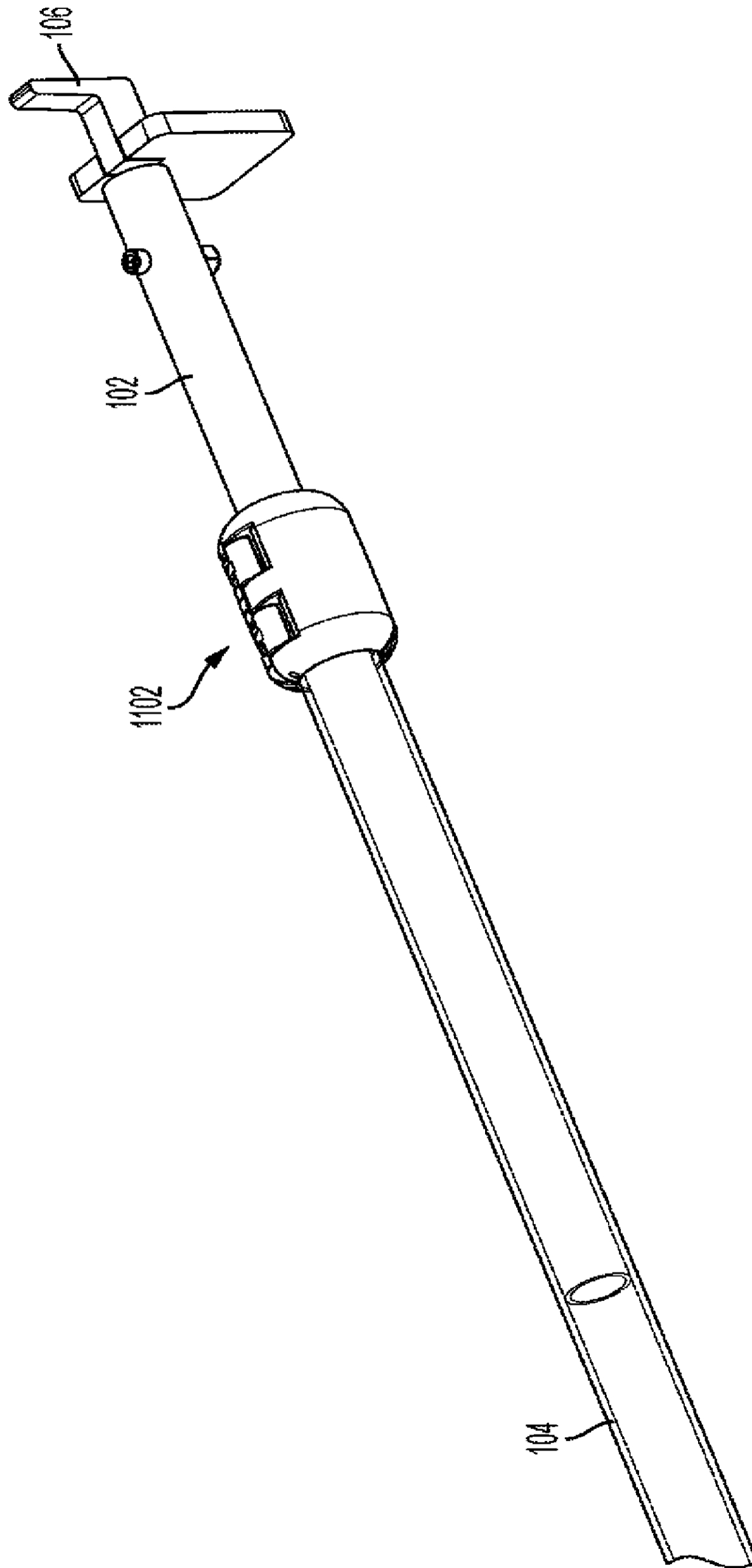

FIG. 16

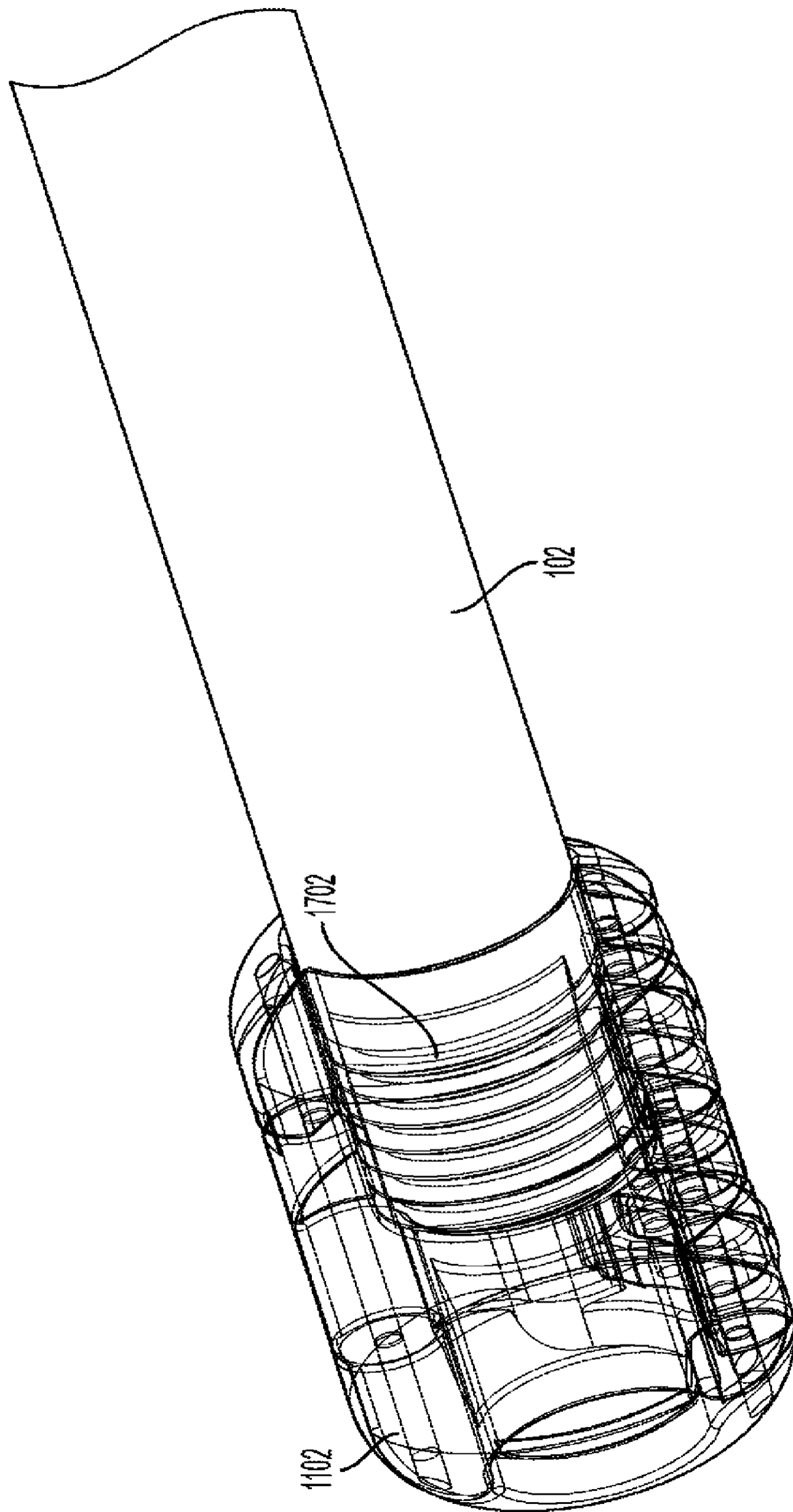

FIG. 17

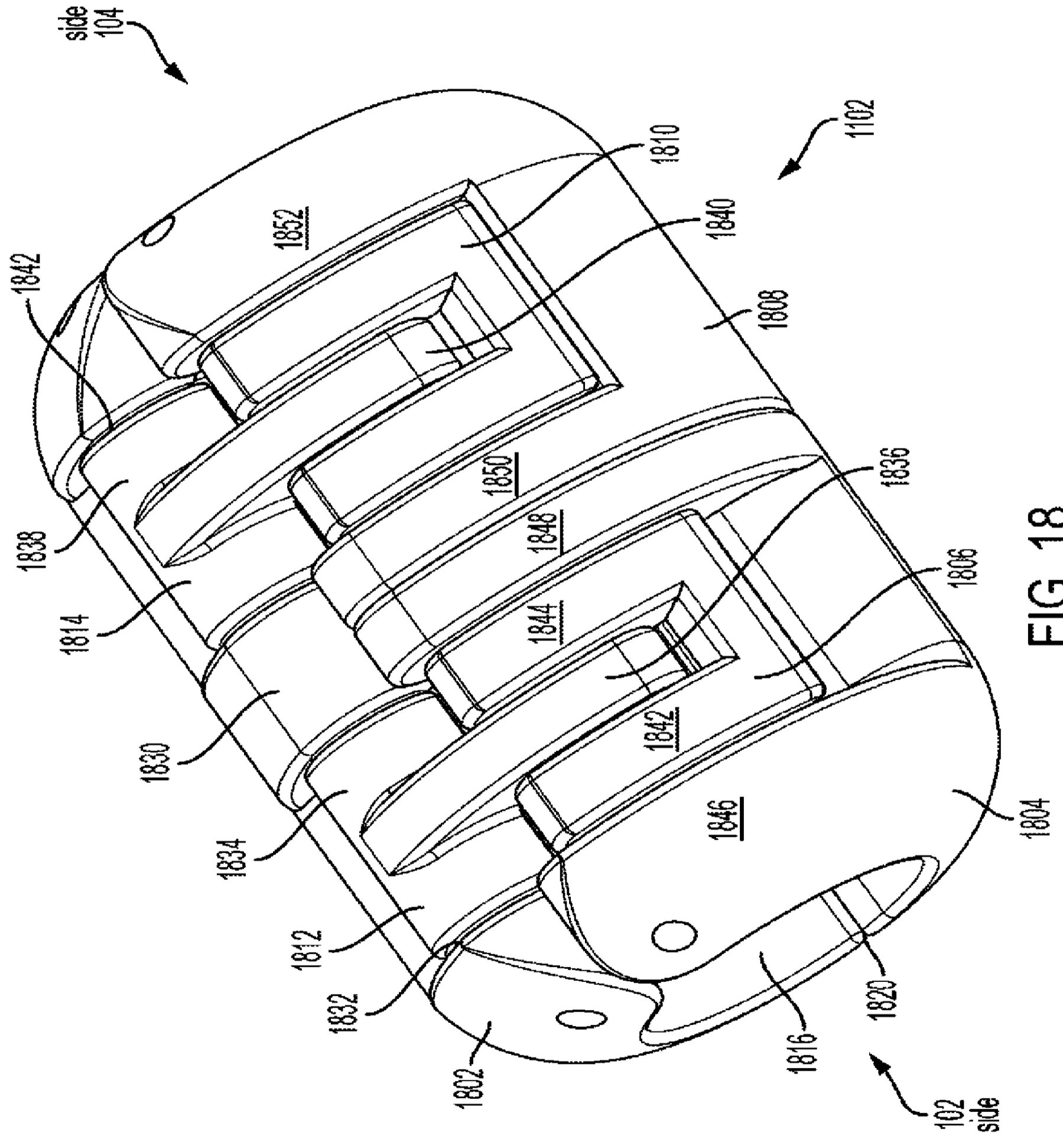

FIG. 18

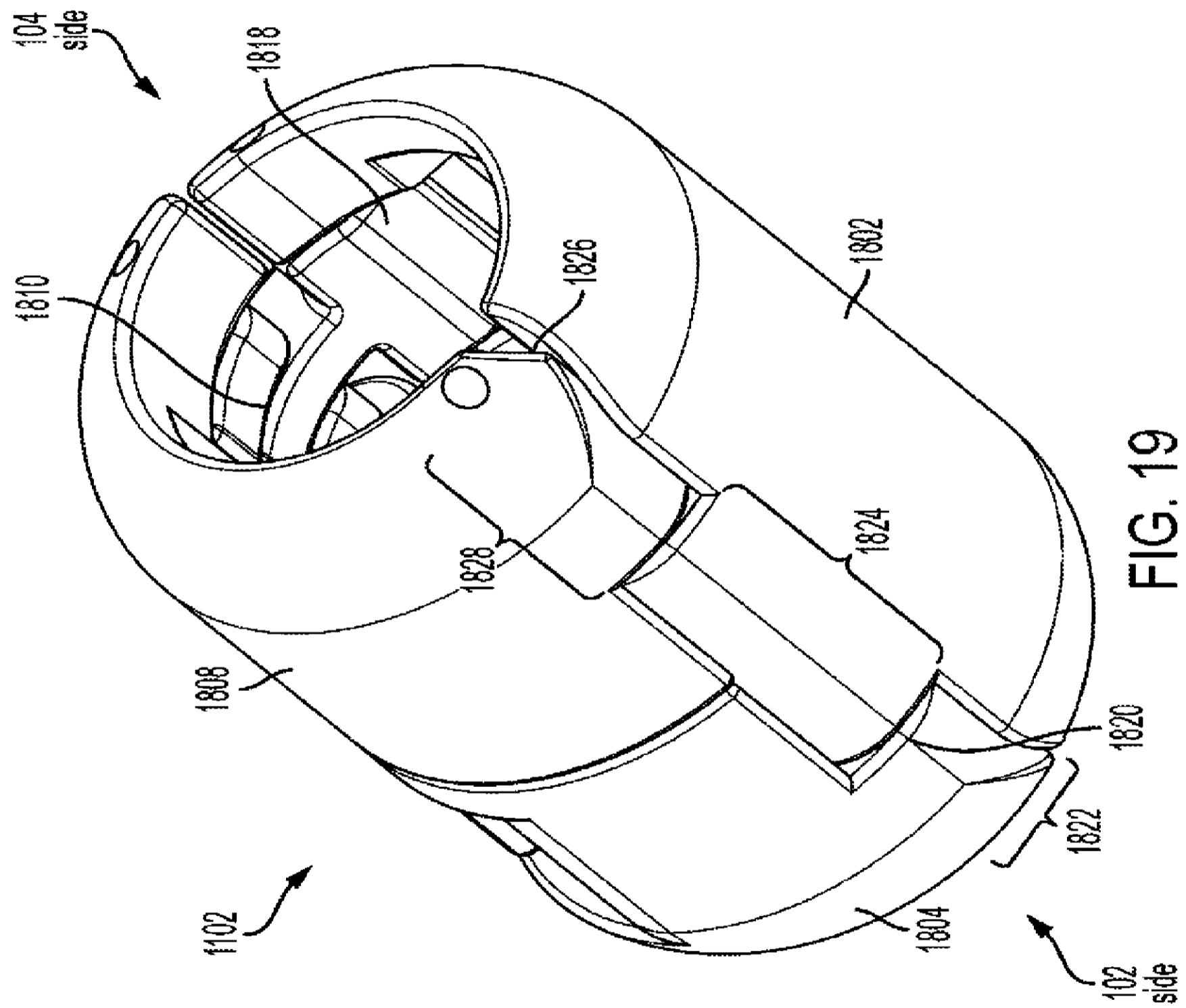

FIG. 19

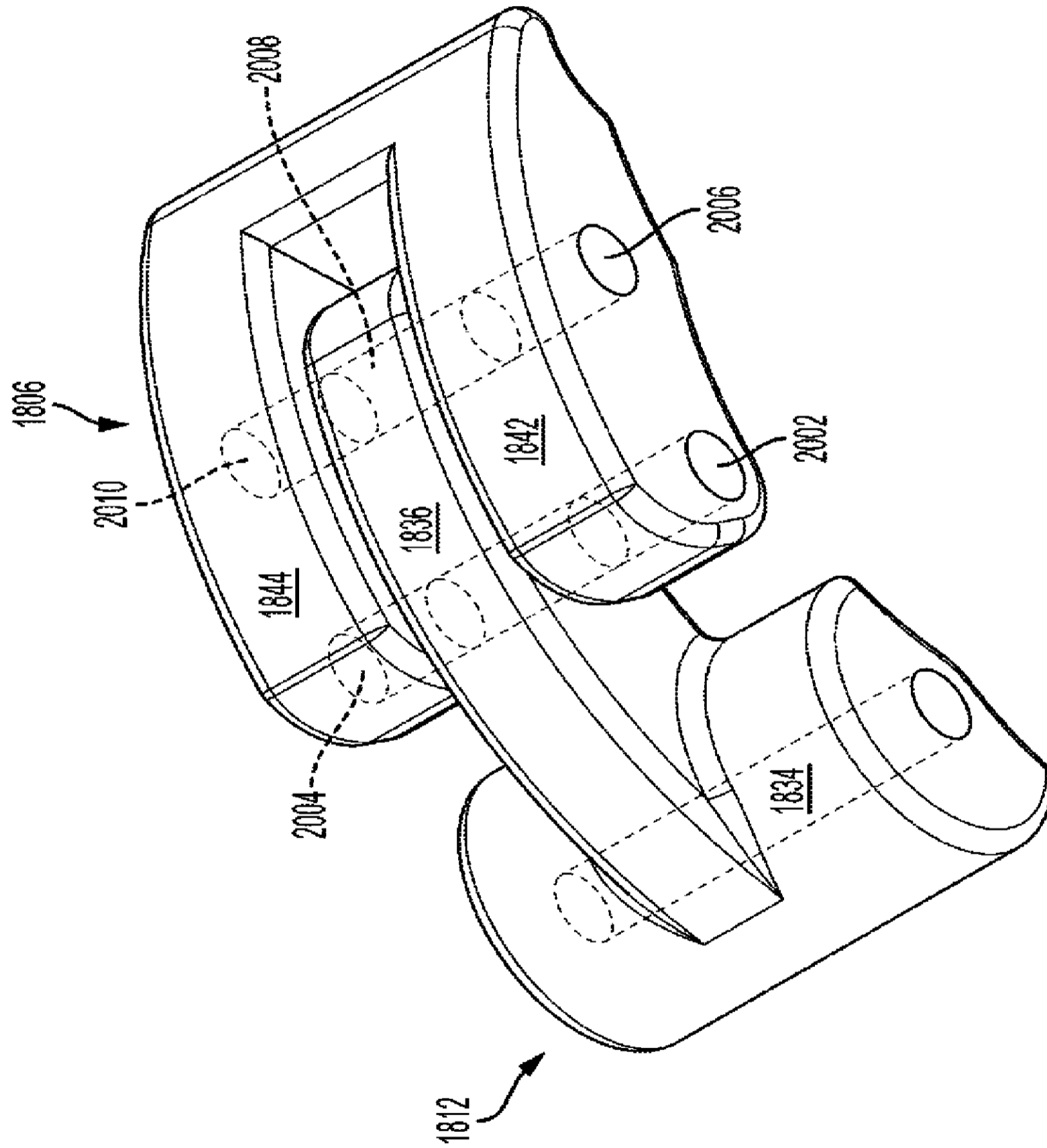

FIG. 20

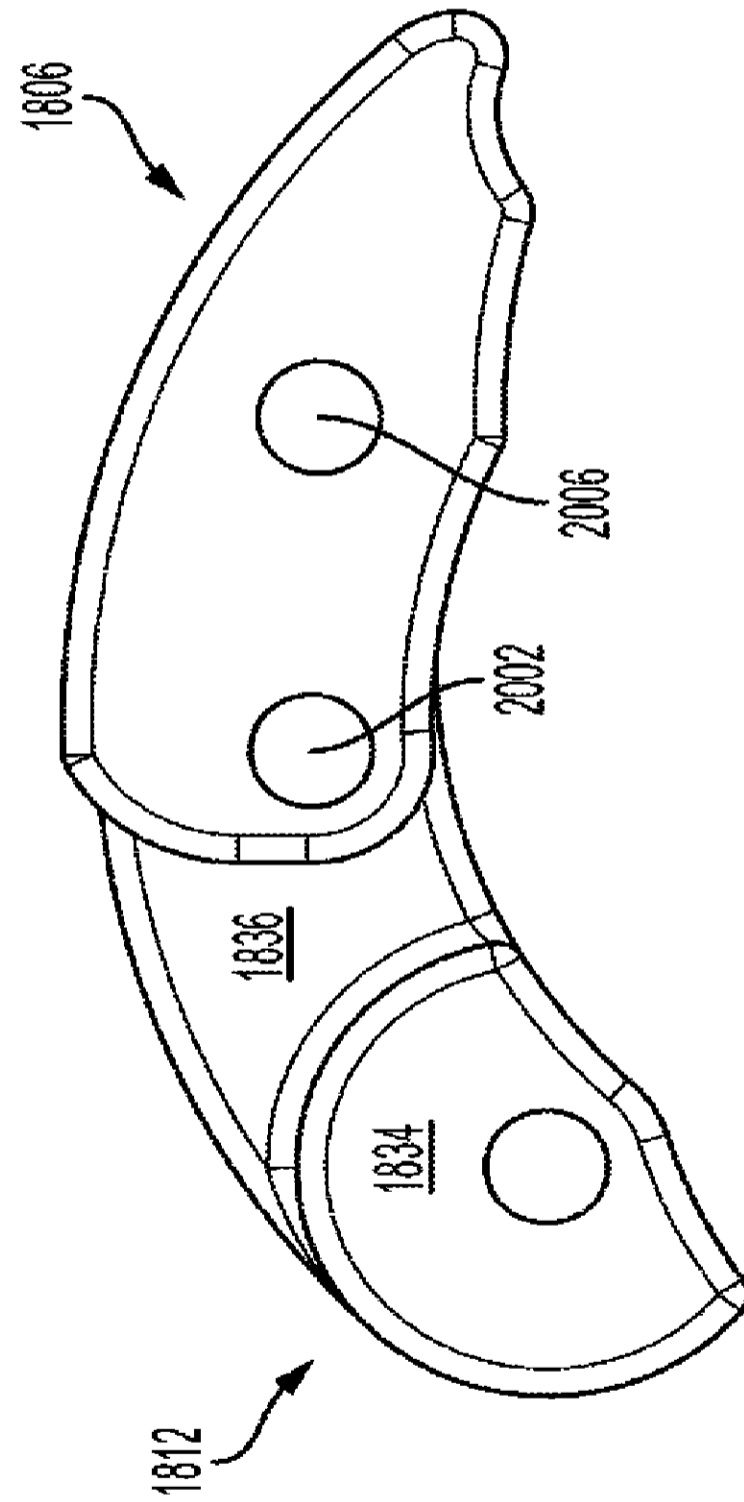

FIG. 21

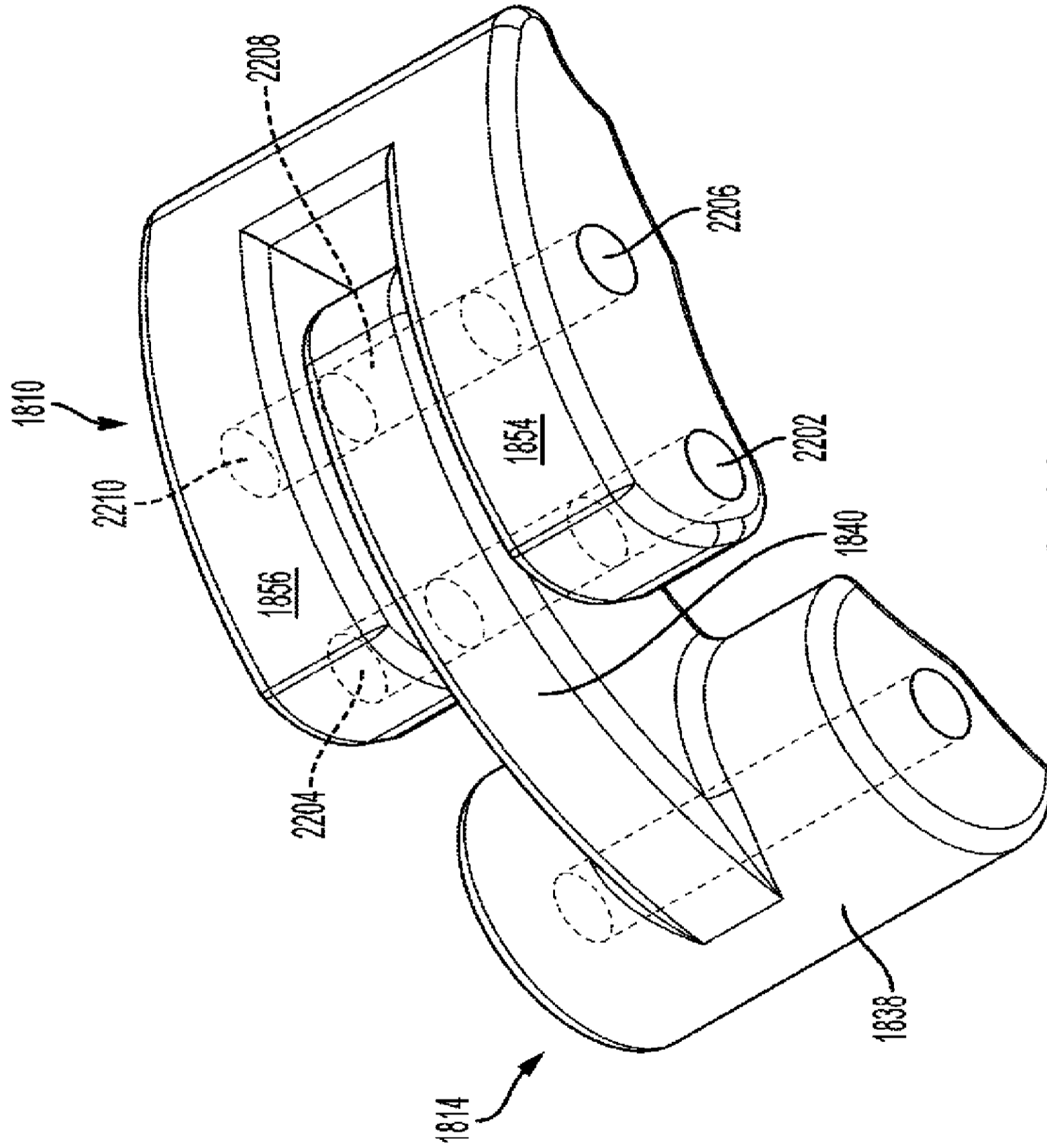

FIG. 22

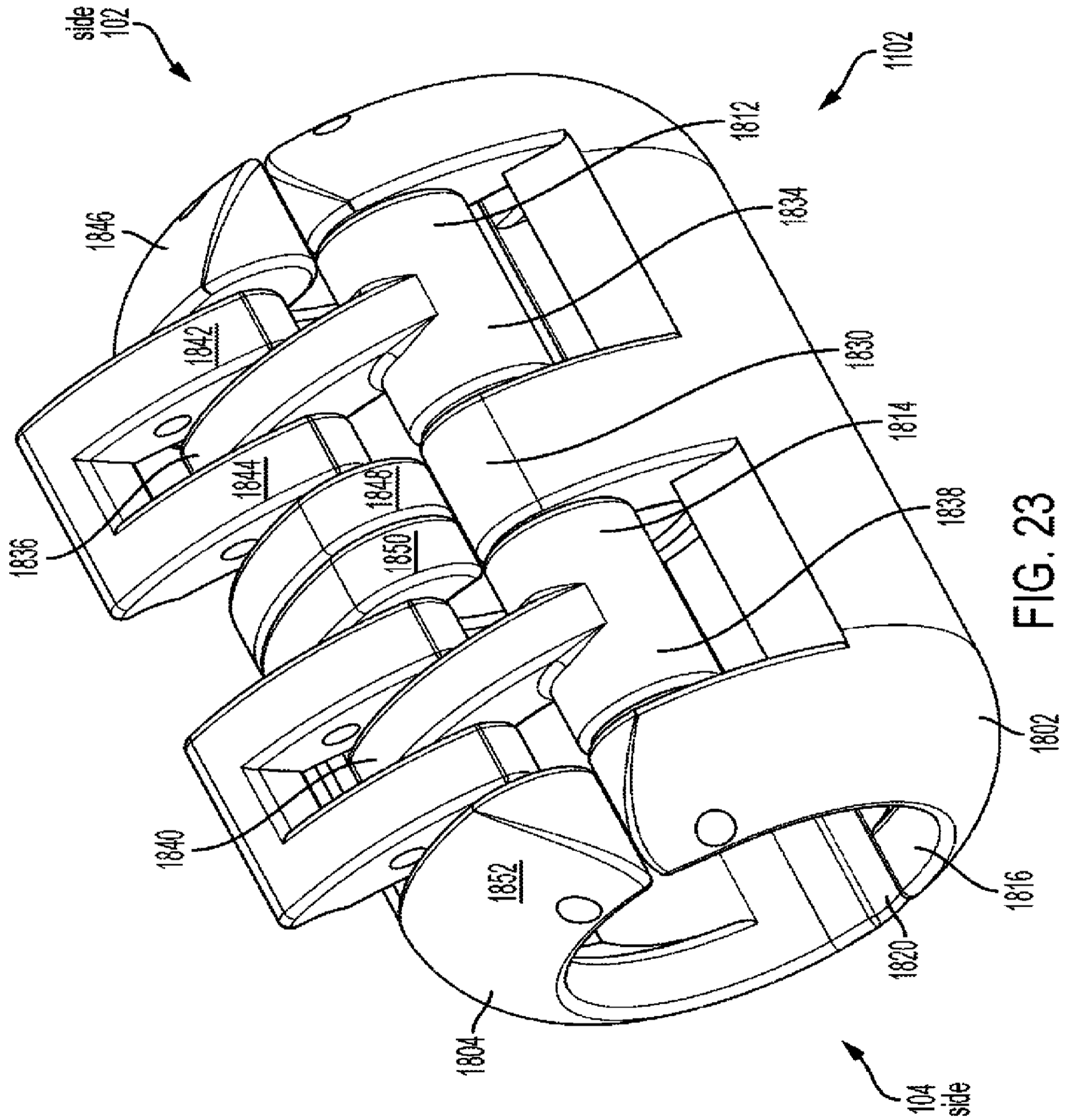
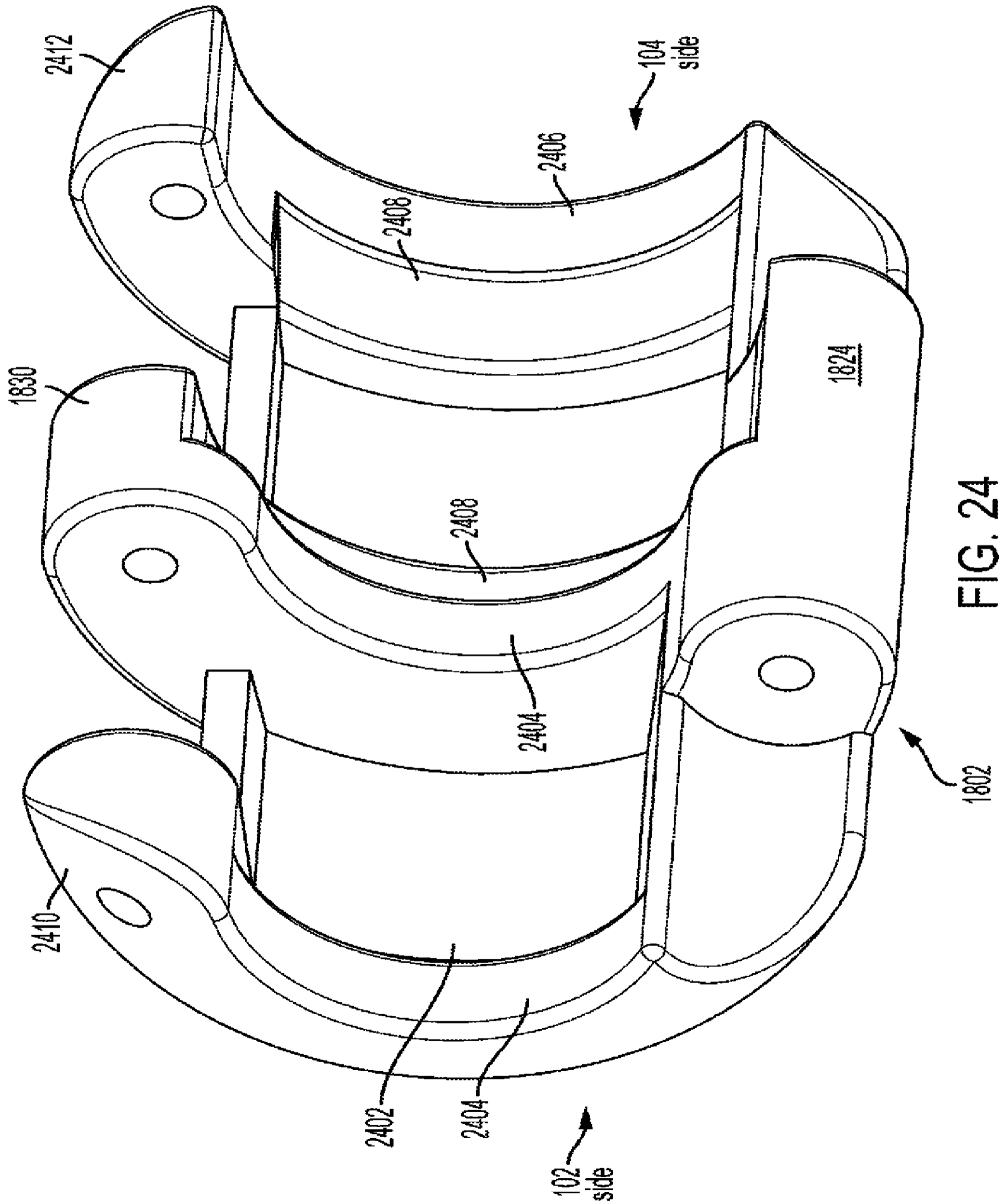

FIG. 23



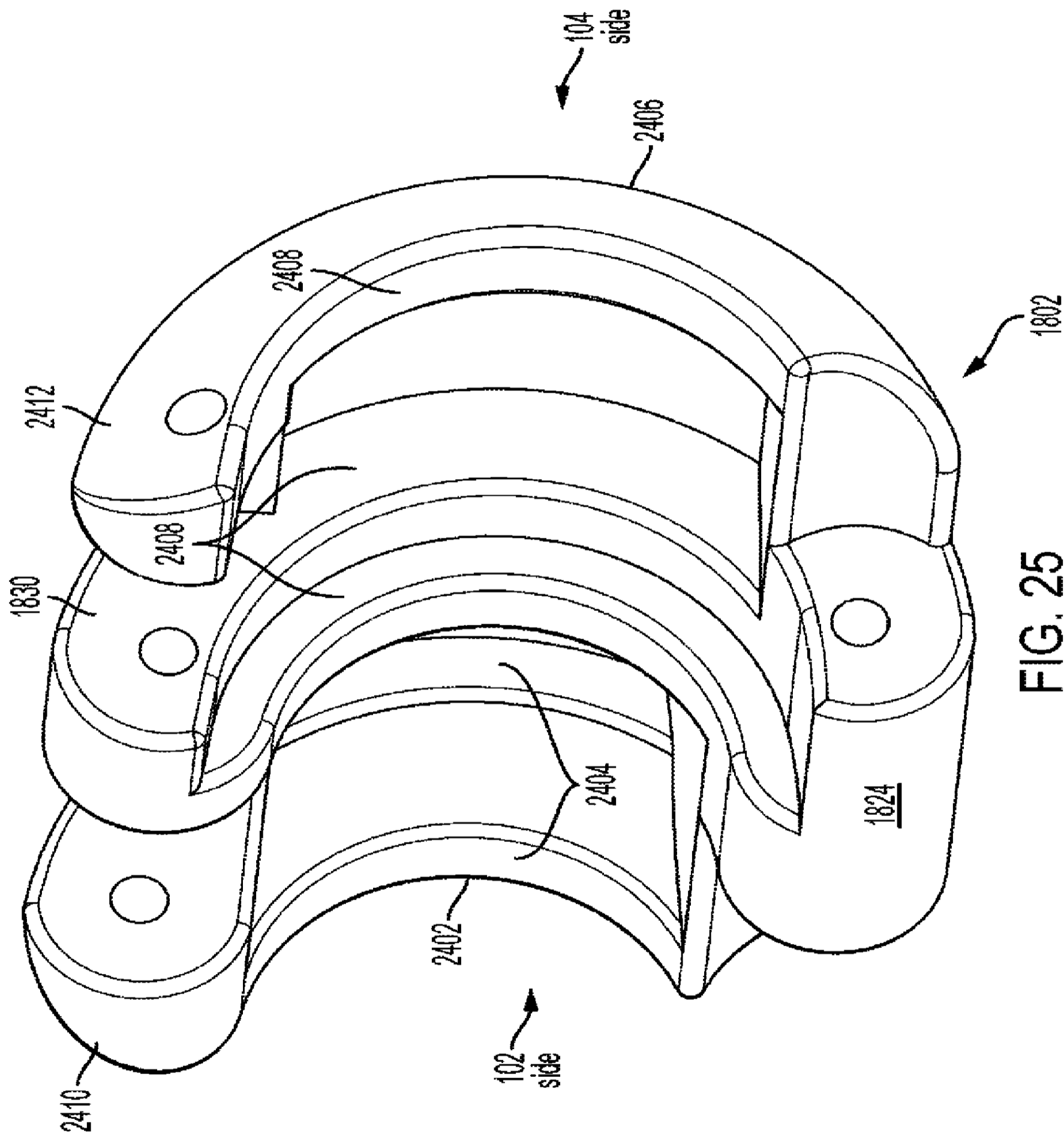

FIG. 25

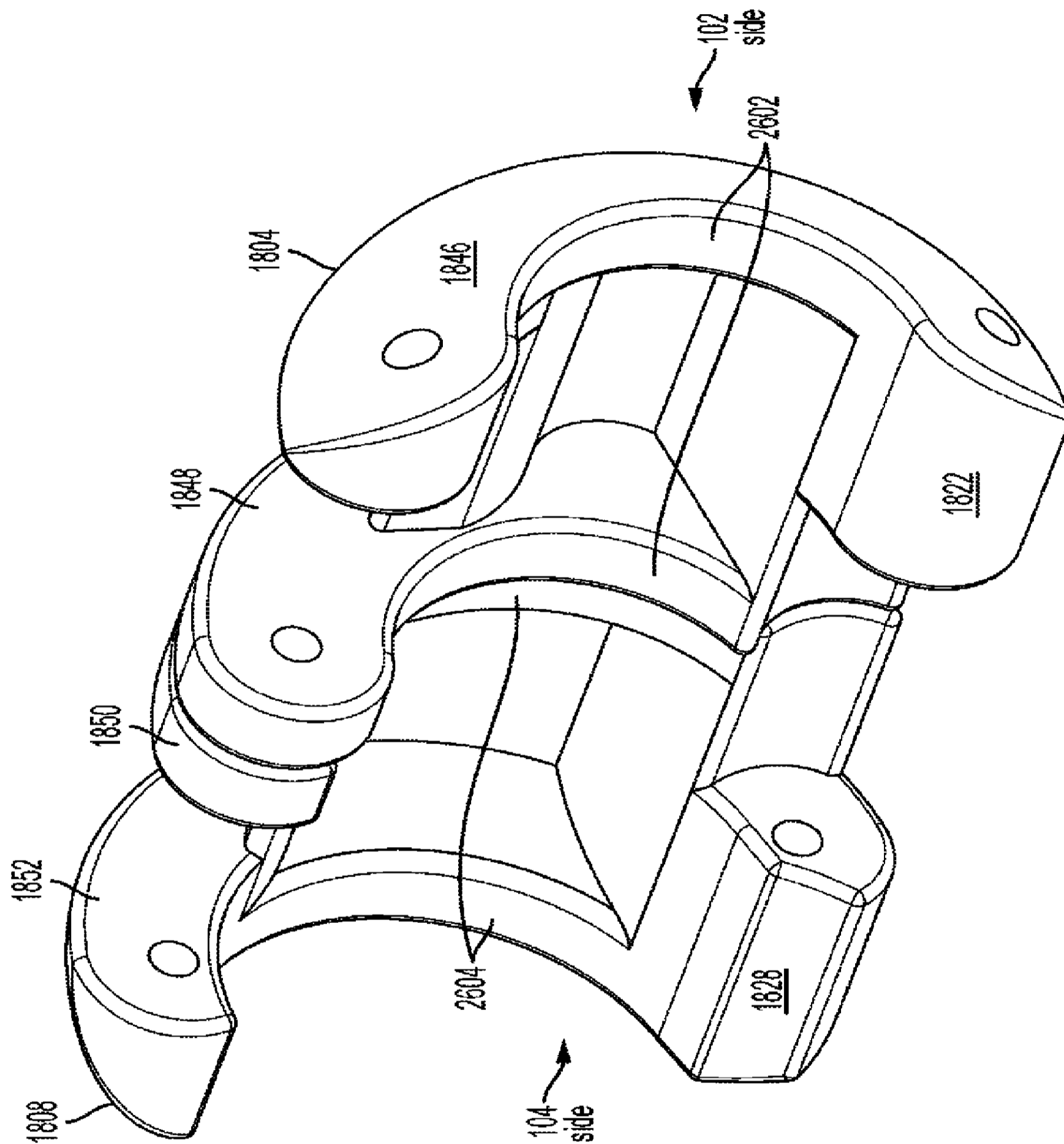

FIG. 26

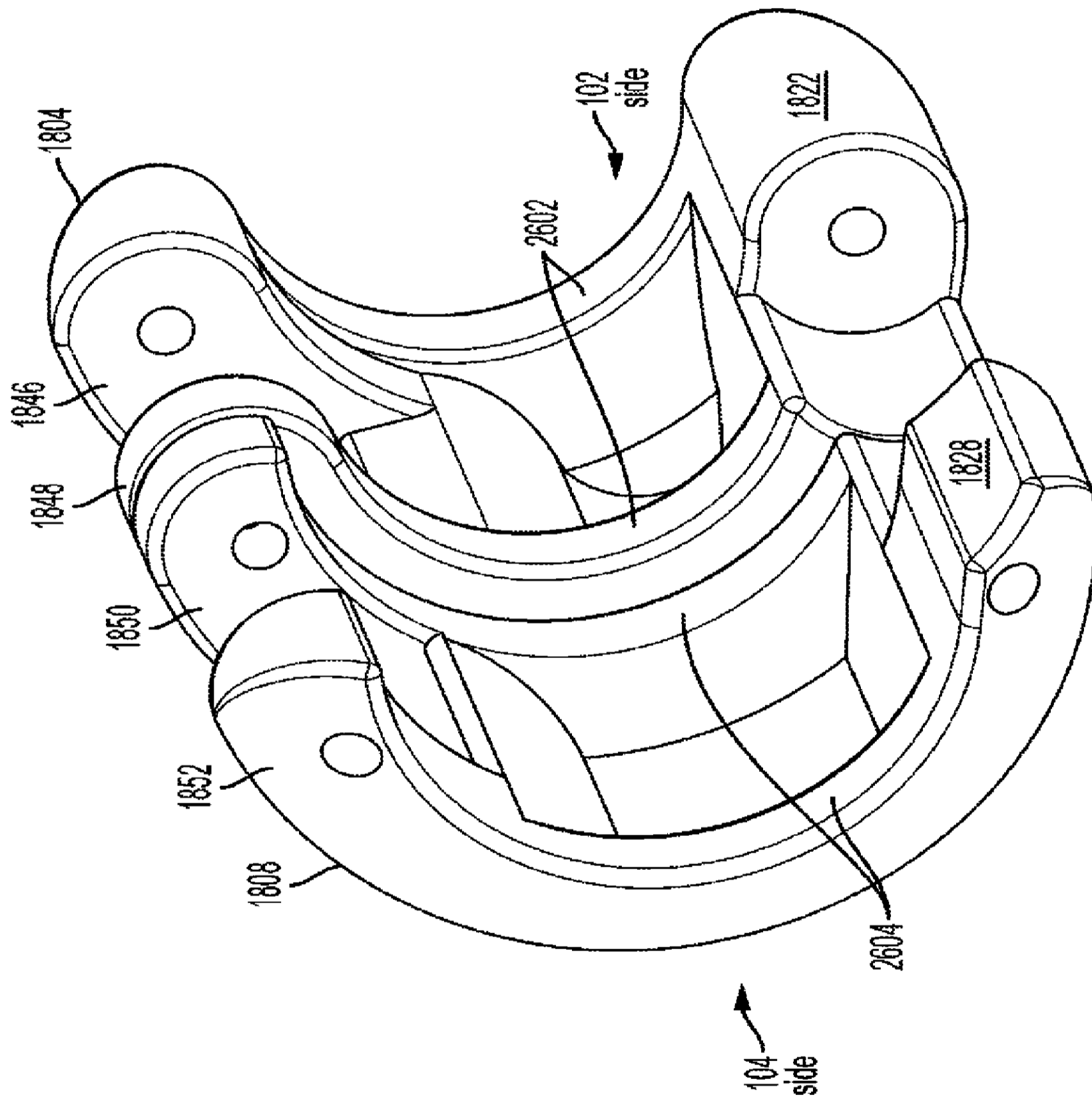

FIG. 27

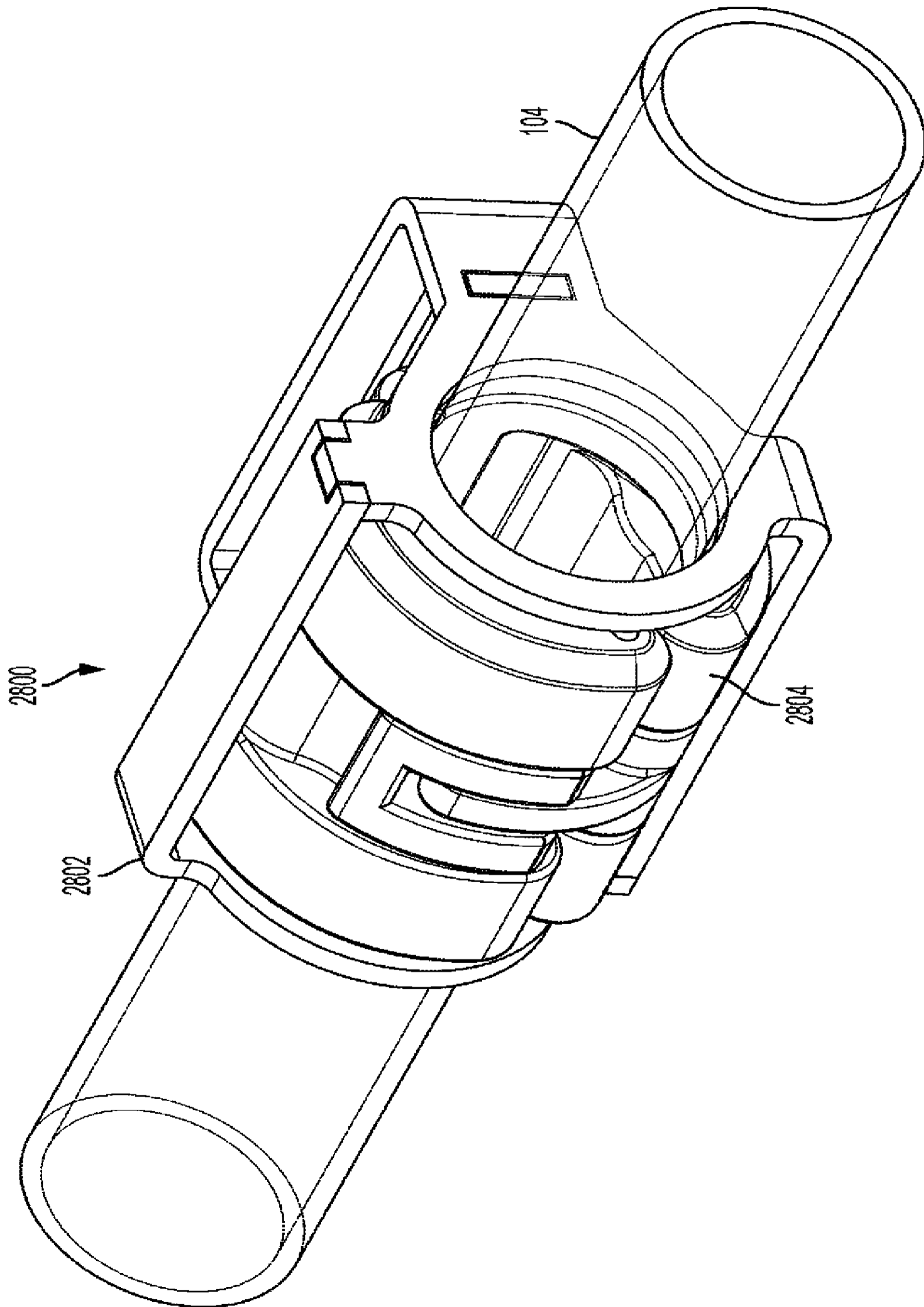

FIG. 28

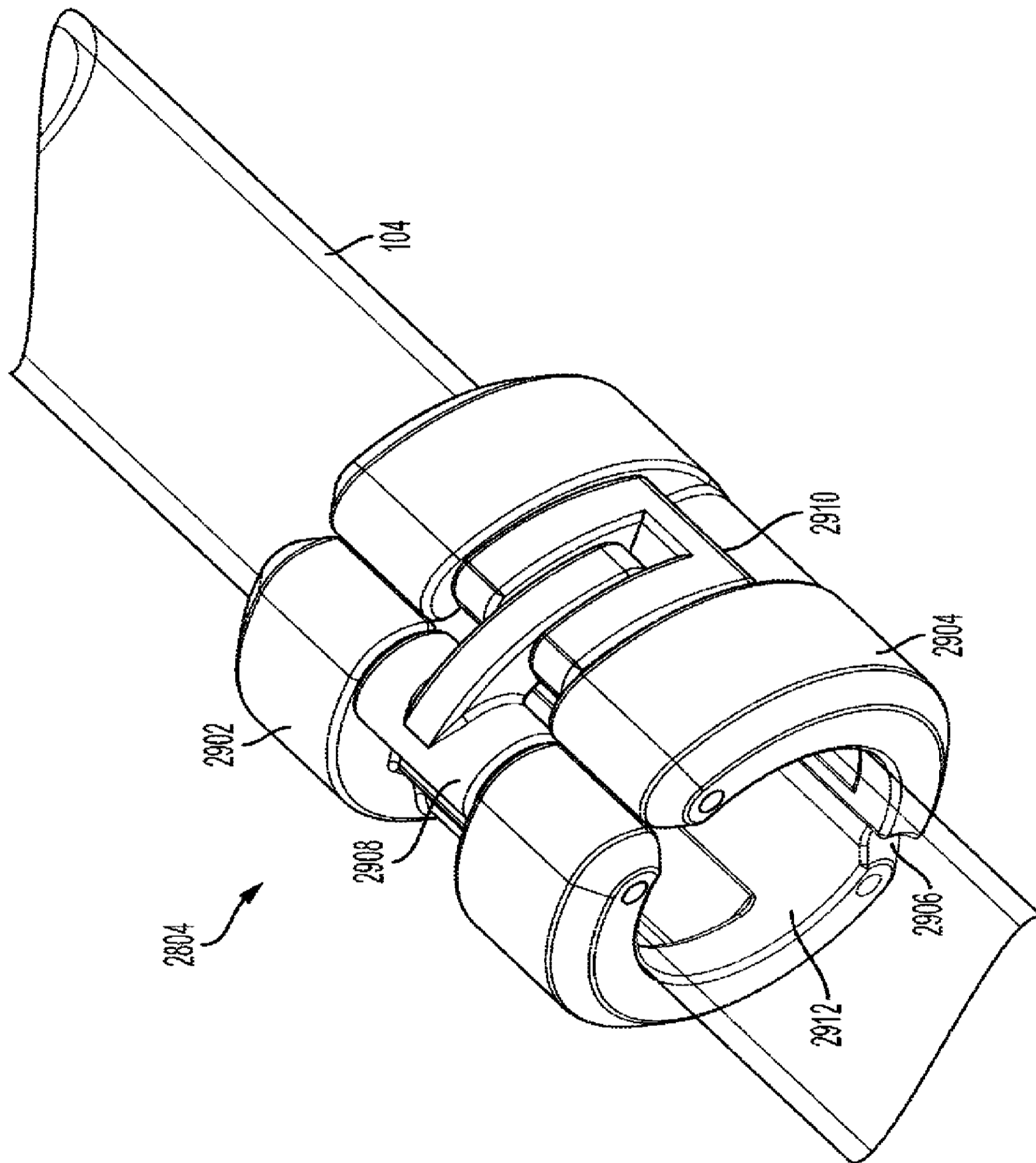

FIG. 29

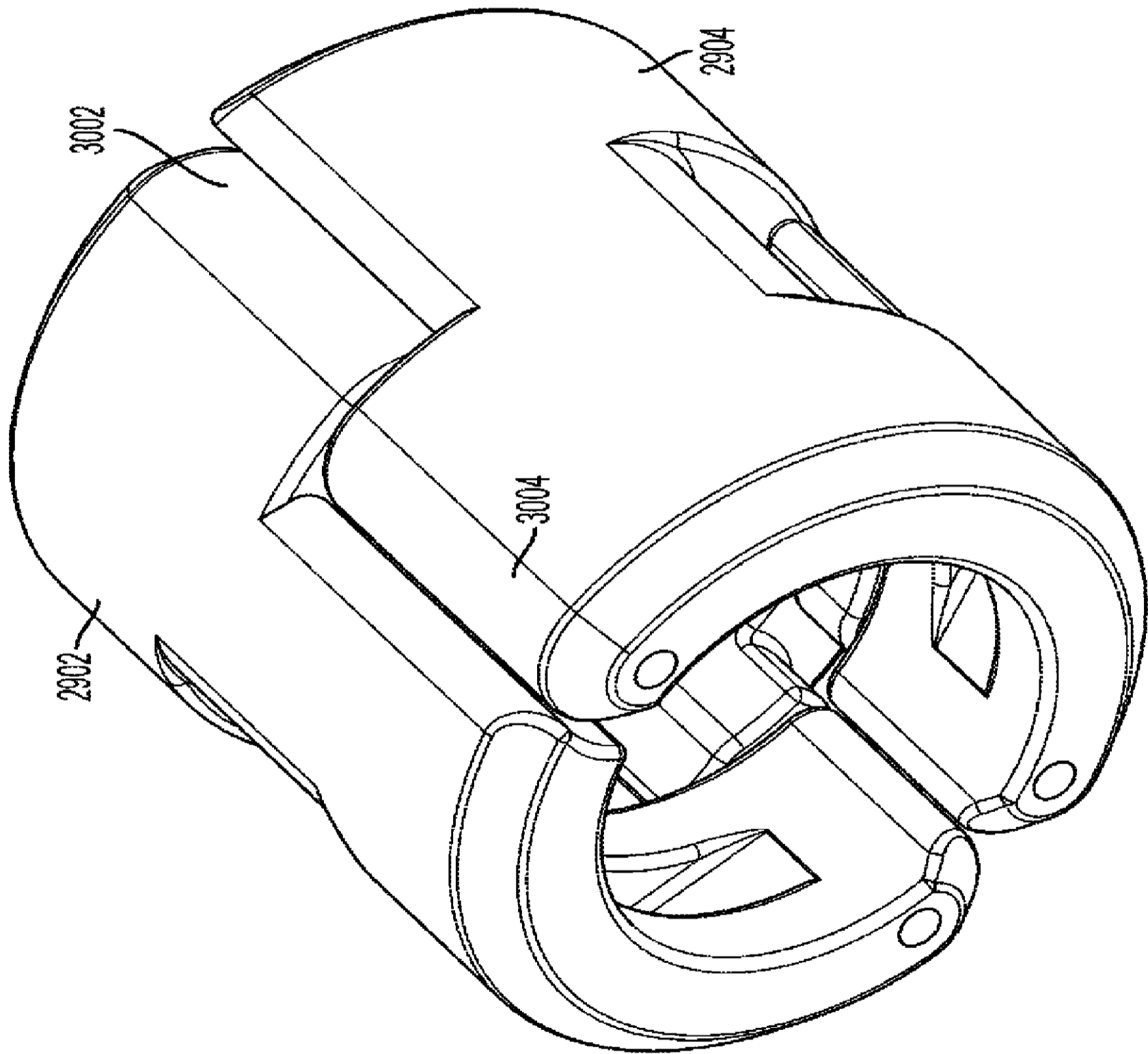

FIG. 30

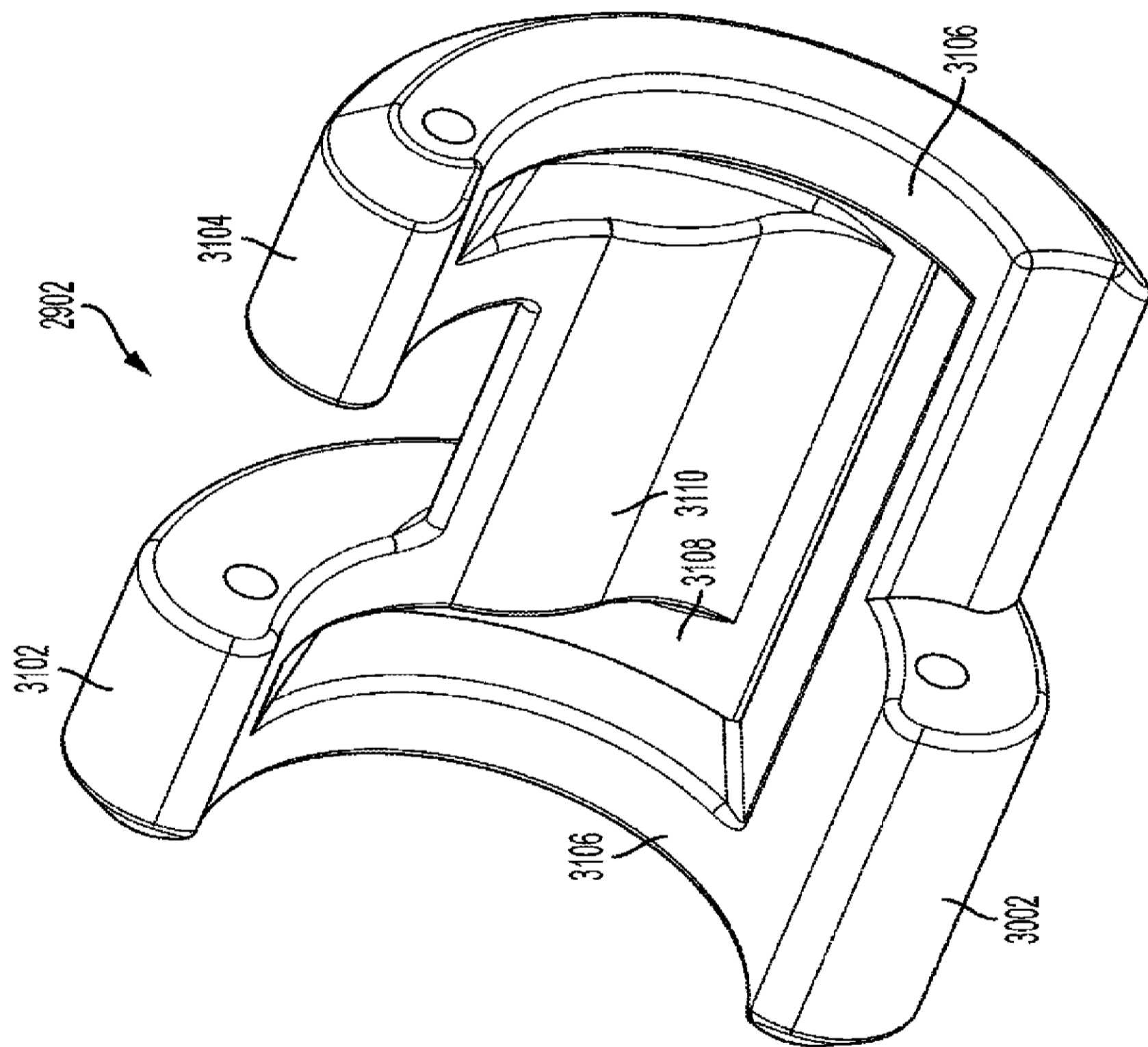

FIG. 31

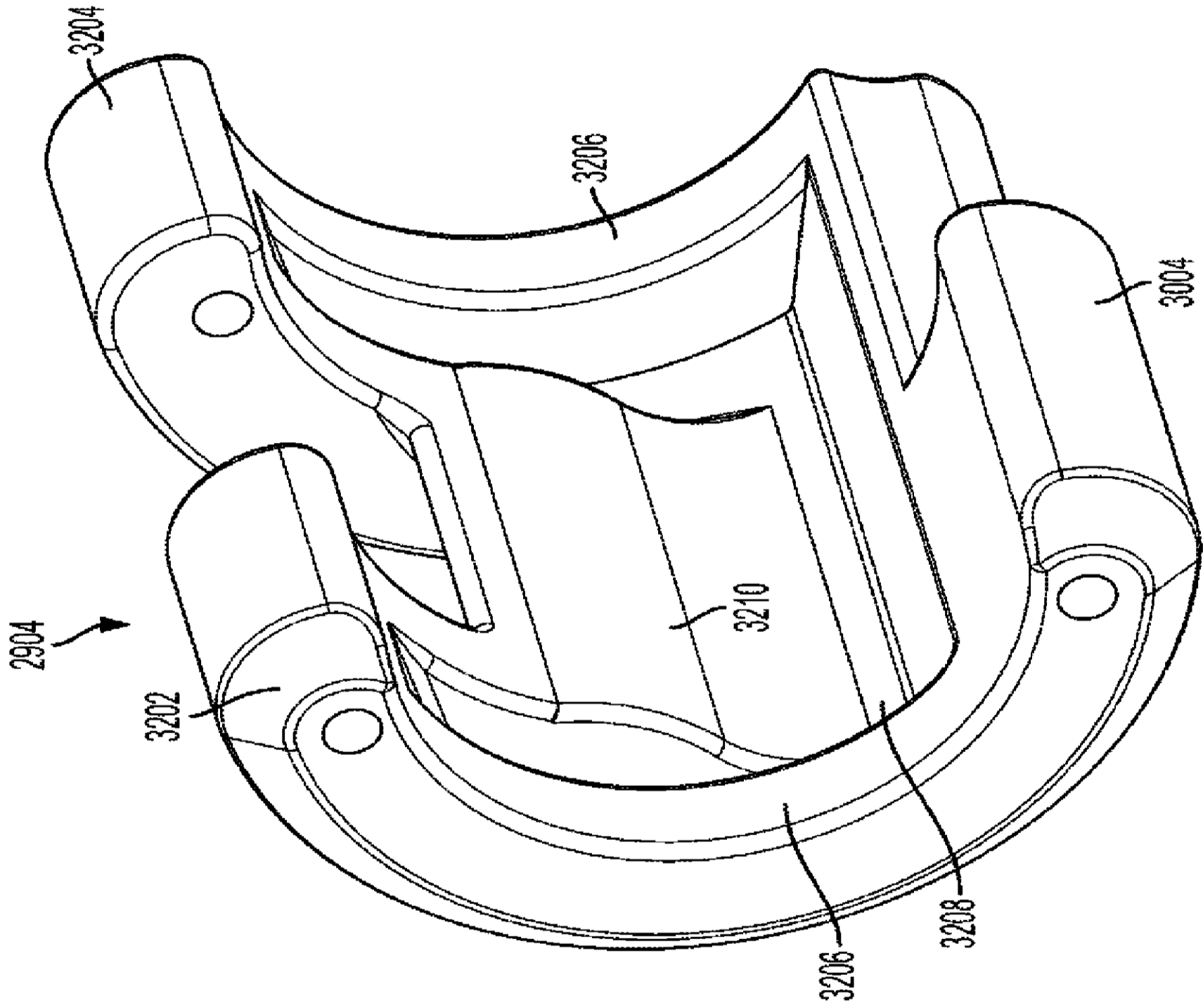

FIG. 32

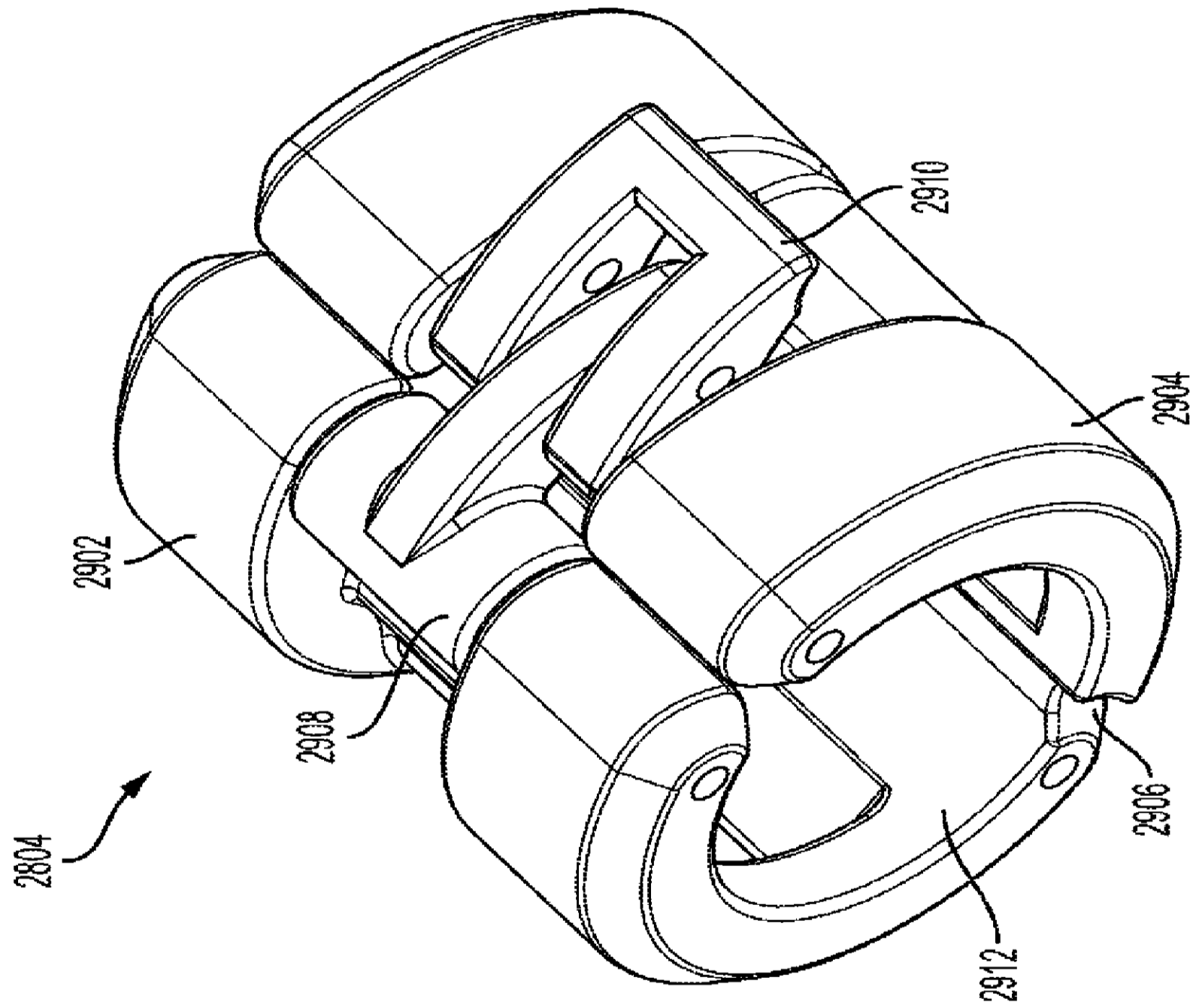

FIG. 33

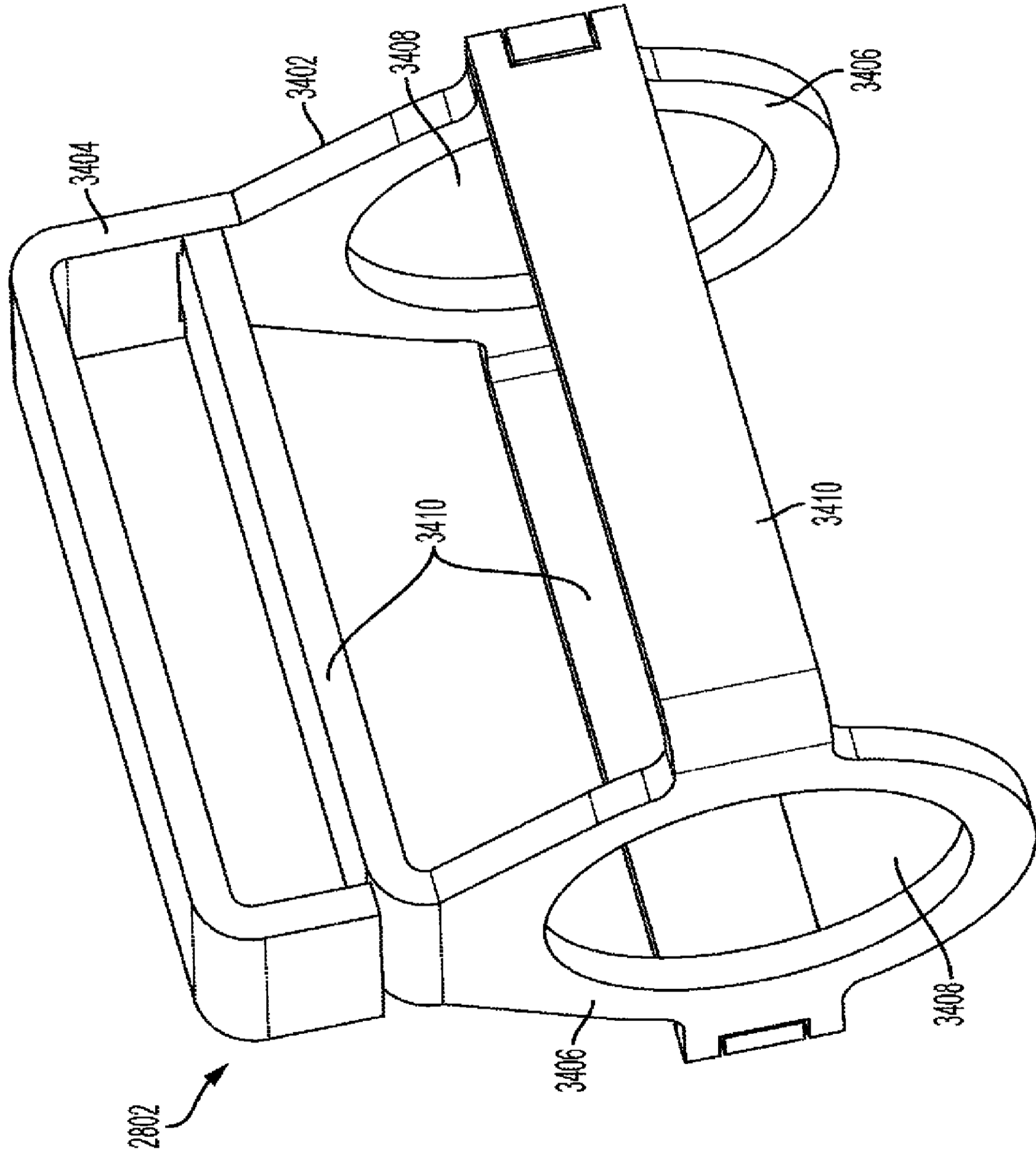

FIG. 34

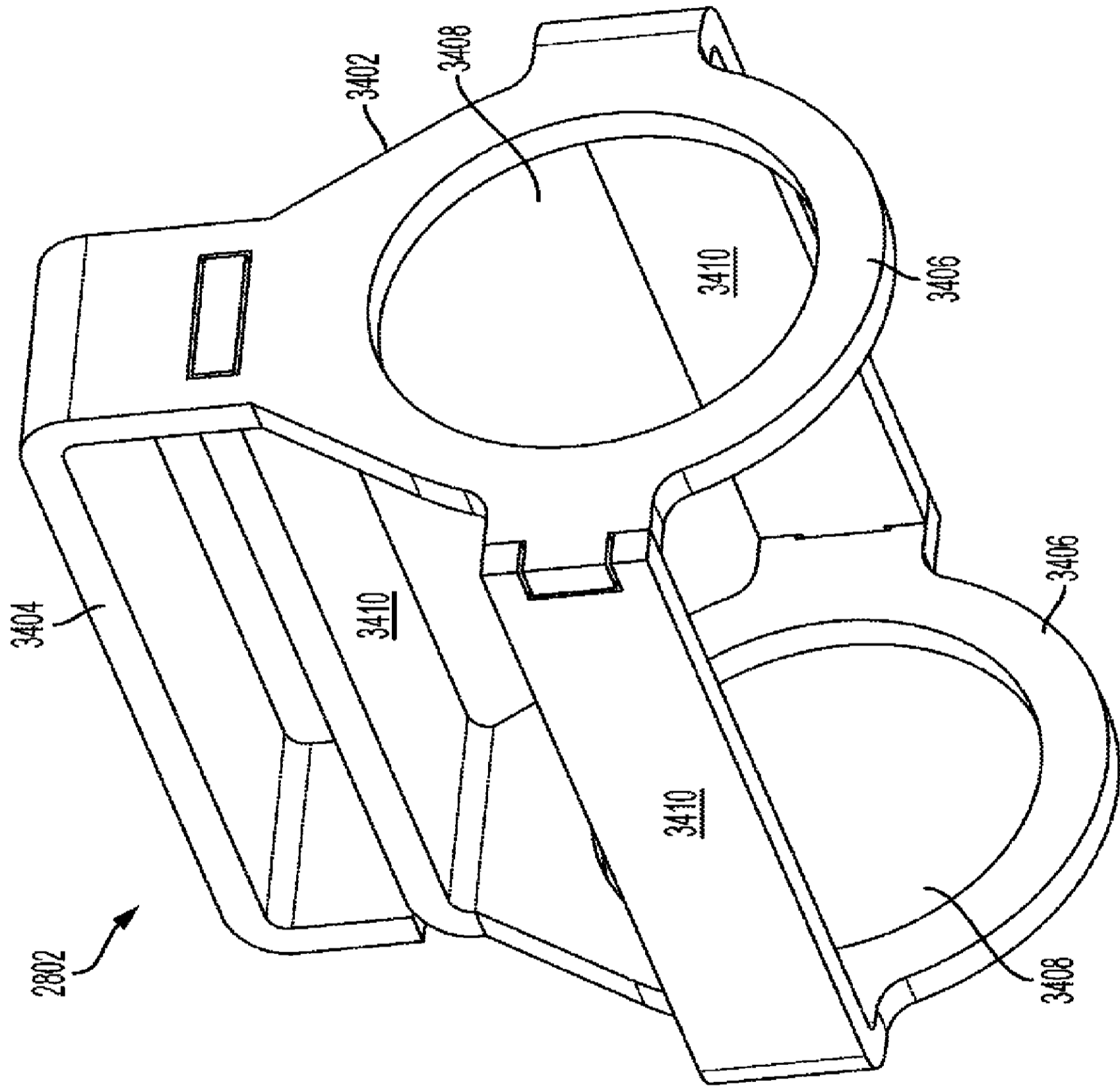

FIG. 35

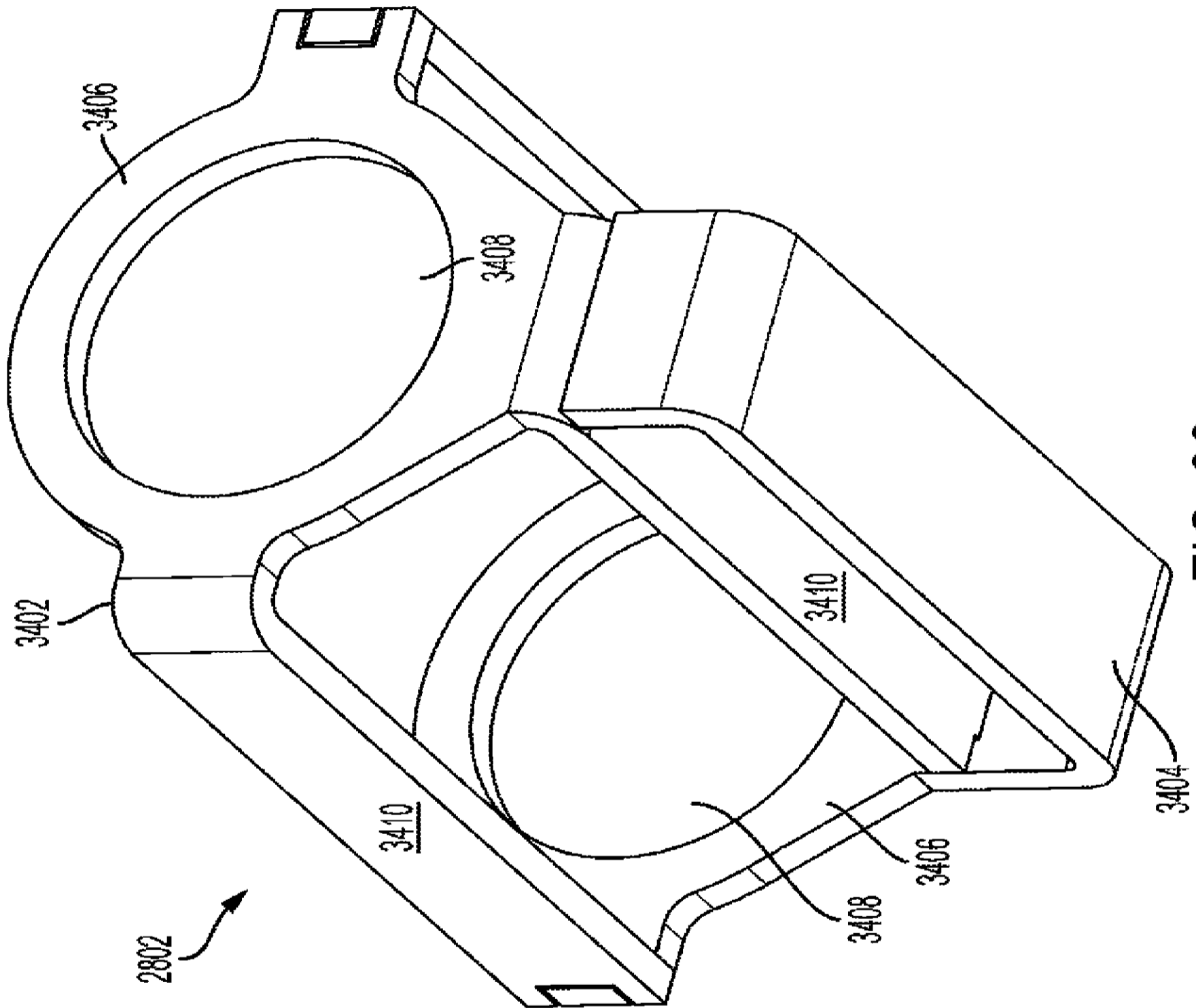

FIG. 36

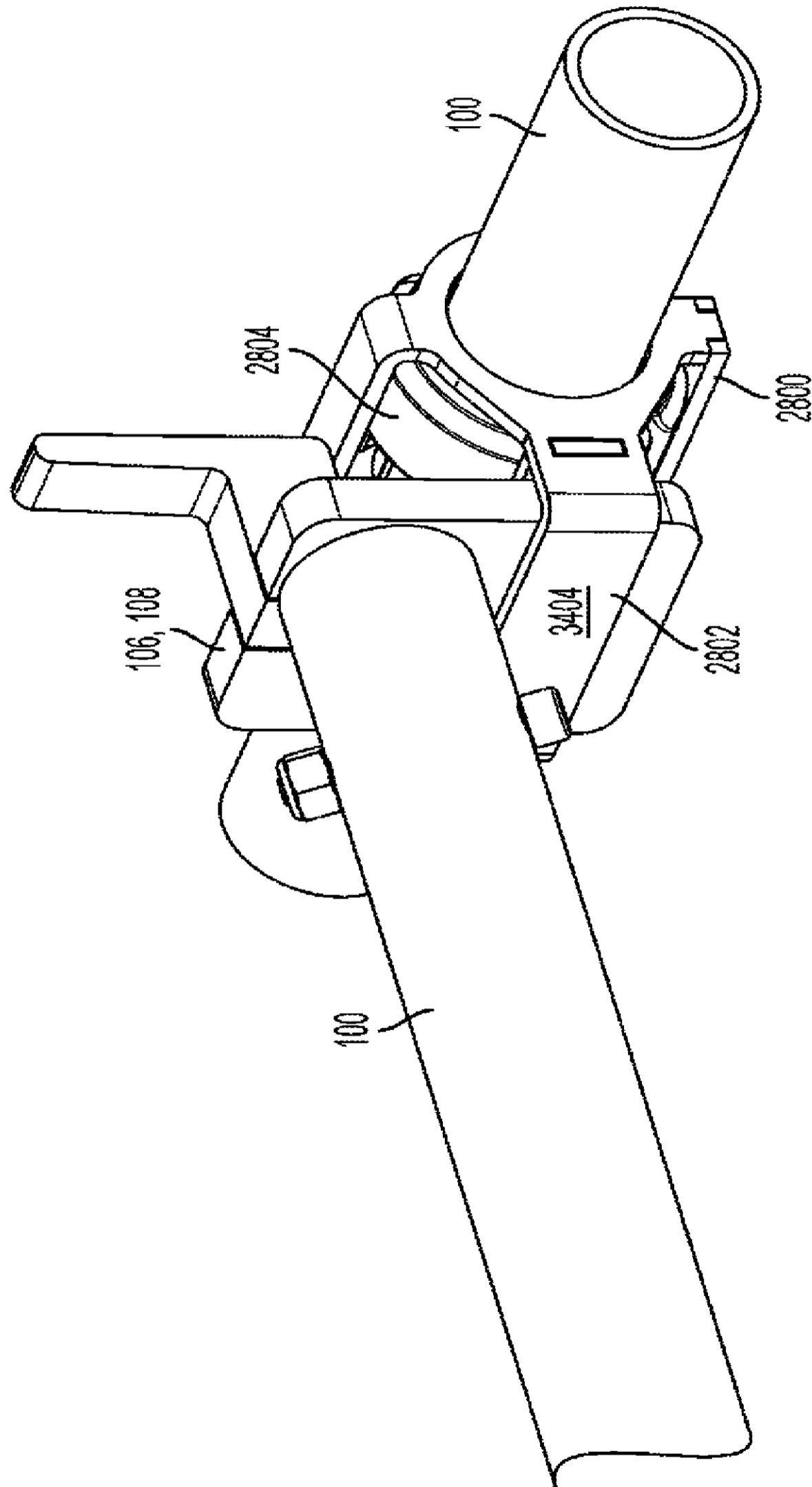

FIG. 37

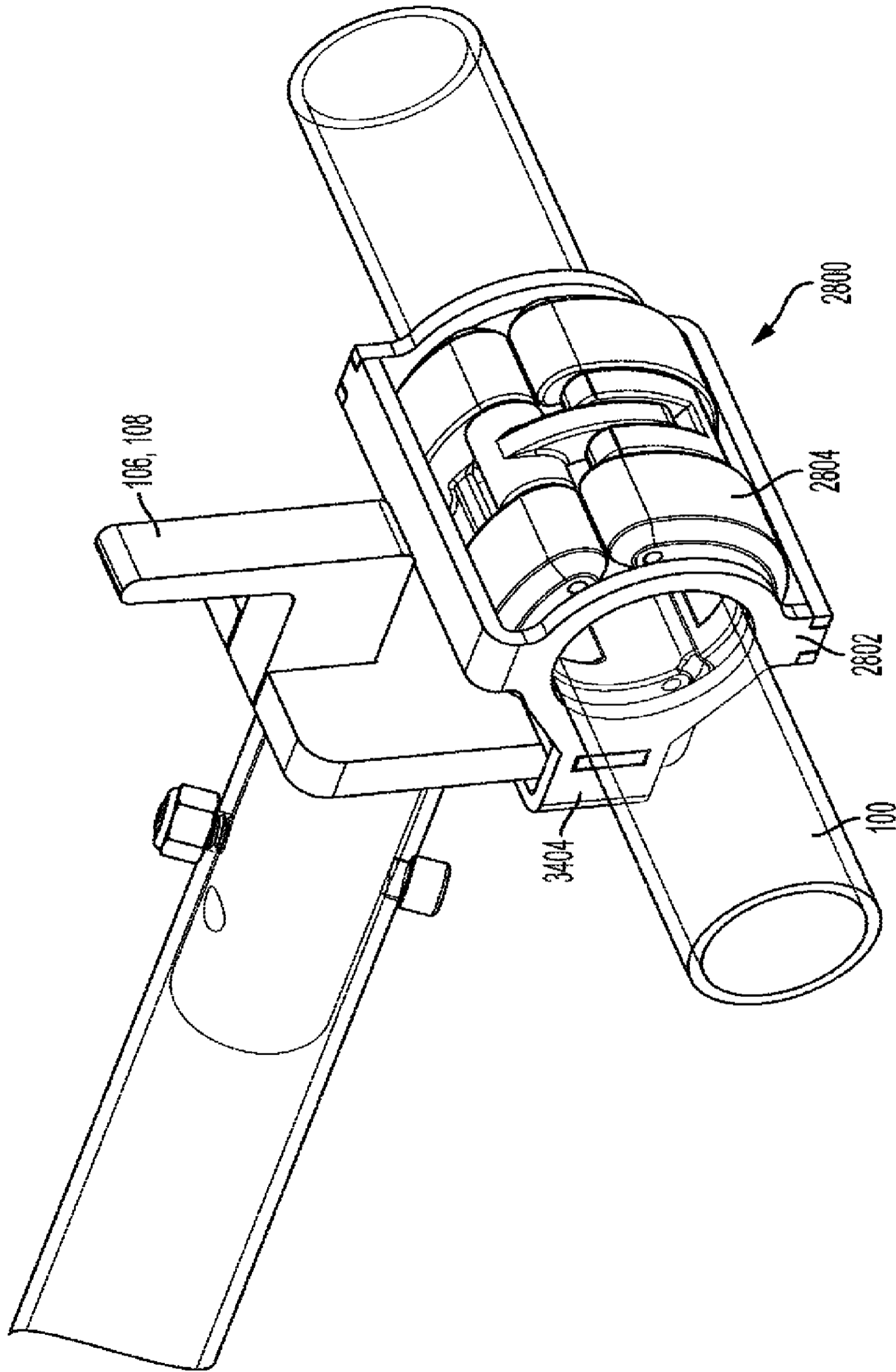

FIG. 38

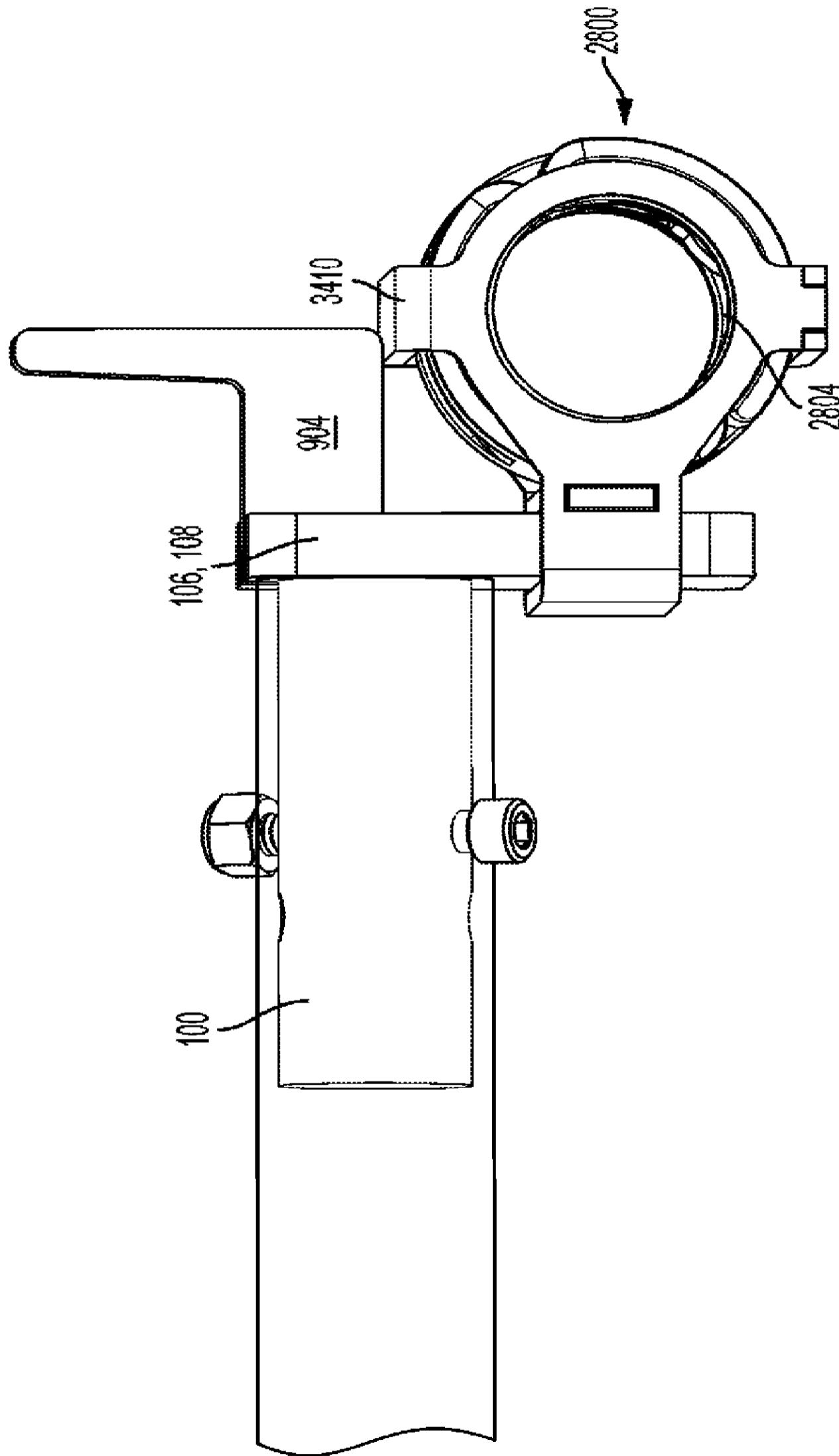

FIG. 39

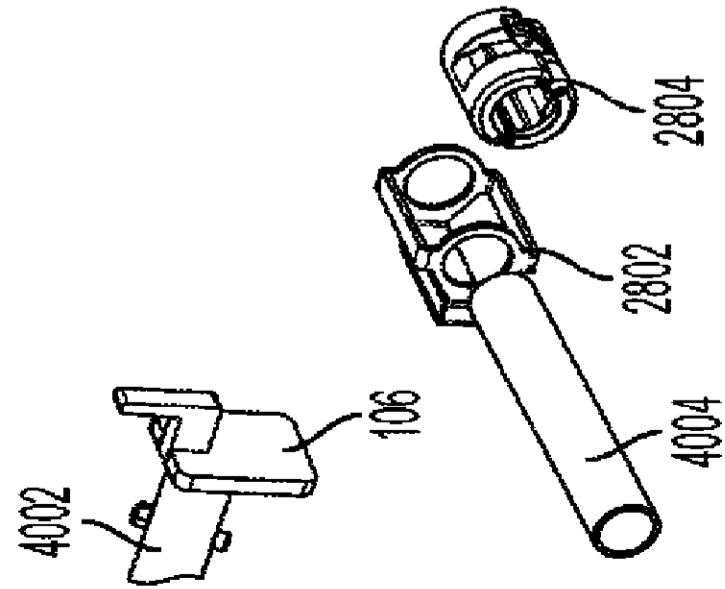

FIG. 40

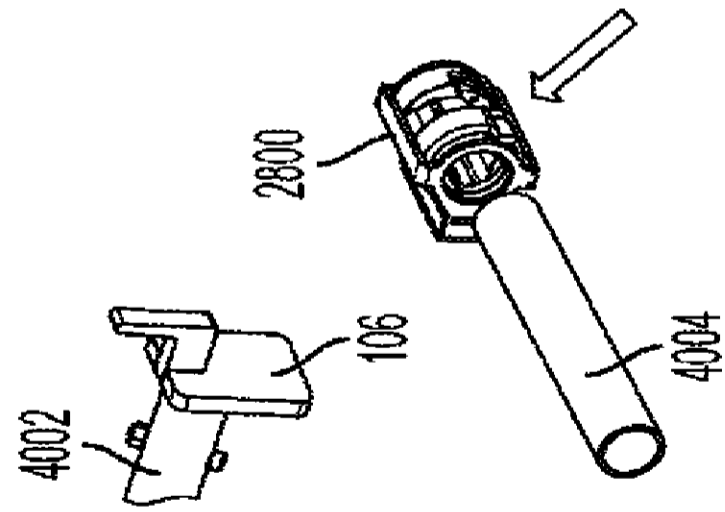

FIG. 41

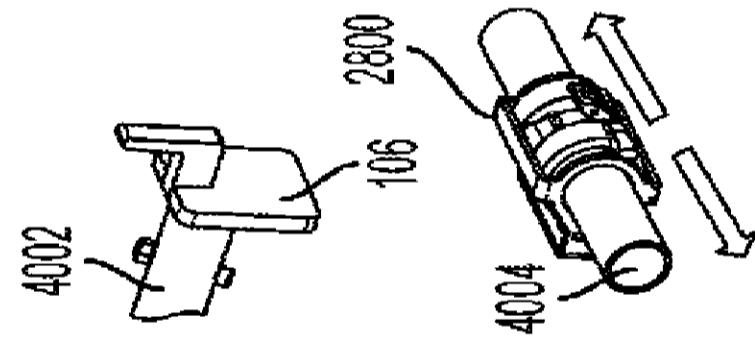

FIG. 42

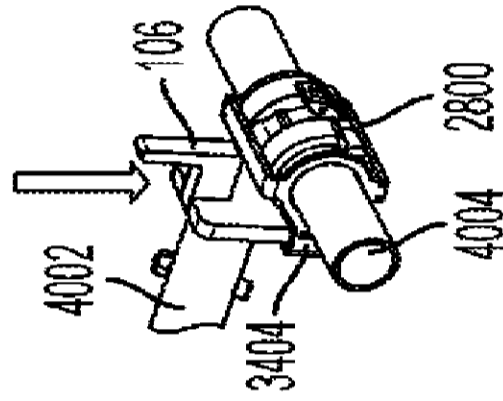

FIG. 43

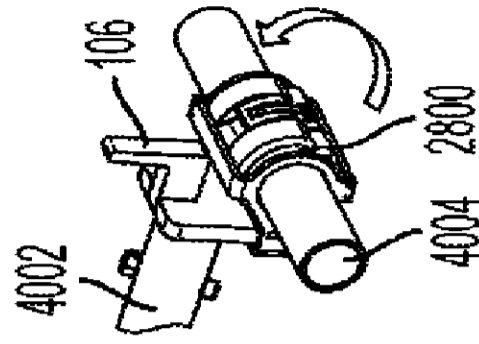

FIG. 44

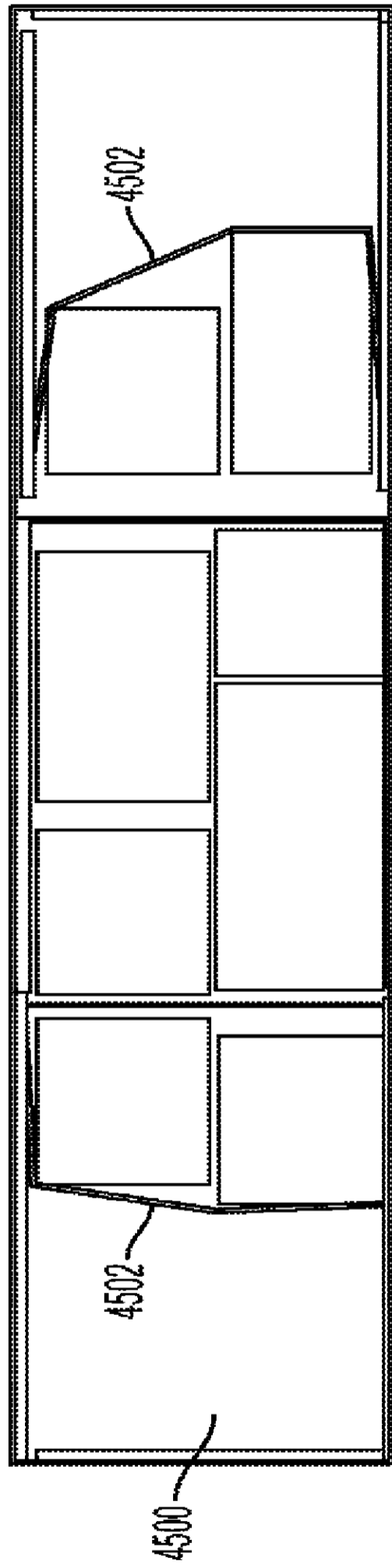

FIG. 45
RELATED ART

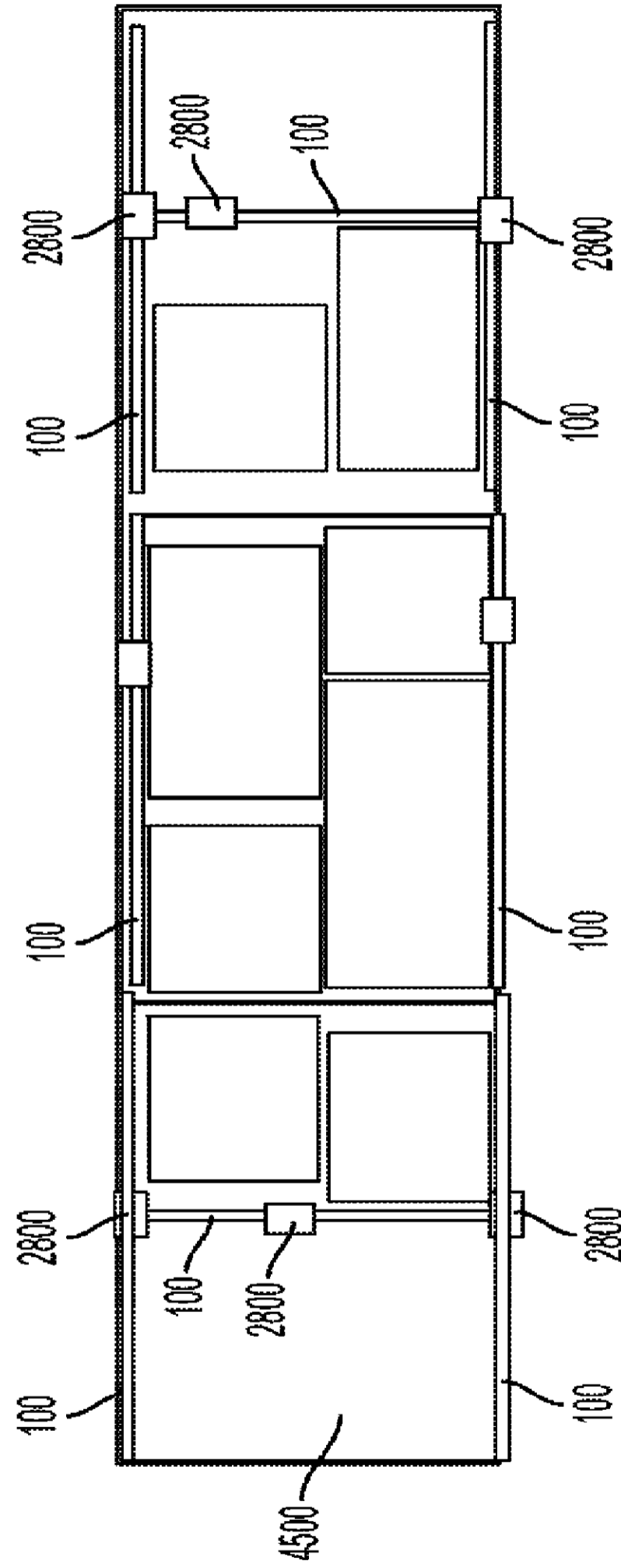

FIG. 46

