



(12) **United States Design Patent**
Deng et al.

(10) **Patent No.:** **US D763,169 S**
(45) **Date of Patent:** **** Aug. 9, 2016**

(54) **VEHICLE ASSIST DEVICE**

(71) Applicant: **E. MISHAN & SONS, INC.**, New York, NY (US)

(72) Inventors: **Daniel Deng**, Dongguan (CN); **Debbie Feuerstein**, Riverdale, NY (US); **Fred Hollinger**, Monroe Township, NJ (US)

(73) Assignee: **E. MISHAN & SONS, INC.**, New York, NY (US)

(**) Term: **15 Years**

(21) Appl. No.: **29/541,239**

(22) Filed: **Oct. 1, 2015**

Related U.S. Application Data

(63) Continuation-in-part of application No. 29/517,992, filed on Feb. 19, 2015, now Pat. No. Des. 743,324, and a continuation-in-part of application No. 29/526,110, filed on May 6, 2015, and a continuation-in-part of application No. 29/534,989, filed on Aug. 3, 2015.

(51) **LOC (10) Cl.** **12-16**

(52) **U.S. Cl.**
USPC **D12/400; D8/107**

(58) **Field of Classification Search**
USPC D8/107, 300-303; D7/394; D12/114, D12/179, 400, 415, 416; 15/145; 16/110.1, 16/419, 420, 421, 422, 426, 427, 430; 292/207, 216; 280/288.4, 293, 295, 280/304.3, 304.5

CPC Y10T 16/469; Y10T 16/476; Y10T 16/44; Y10T 292/1089; Y10T 16/466; Y10T 16/4713; Y10T 292/57; Y10T 74/20828; Y10T 16/4644; Y10T 16/513; Y10T 29/49826; Y10T 74/20822; Y10T 16/458; Y10T 16/4652; Y10T 74/20732; Y10T 70/5761; Y10T 292/0956; Y10T 16/4559; Y10T 292/1049; Y10T 16/459; Y10T 74/20864; Y10T 70/5889; Y10T 292/1083; Y10T 292/1041; Y10T 70/577; Y10T 292/0891; Y10T 292/0849; Y10T 407/1825;

Y10T 292/1072; Y10S 292/23; Y10S 16/12; Y10S 16/24; Y10S 292/27; Y10S 292/65; Y10S 16/19; Y10S 292/53; Y10S 16/40; Y10S 56/18; B25G 1/102; B25G 1/10; B25G 1/00

See application file for complete search history.

(56) **References Cited**

U.S. PATENT DOCUMENTS

D441,514	S	*	5/2001	Grove	D12/133
D532,274	S	*	11/2006	Demar	D8/107
D535,544	S	*	1/2007	DeBaal	D8/303
D537,311	S	*	2/2007	Peterson	D8/5
D582,005	S	*	12/2008	Eshet	D23/223
D614,011	S	*	4/2010	Hyp	D8/10
D688,020	S	*	8/2013	Workman	D34/27
2004/0078936	A1	*	4/2004	Walker	B25F 5/006 16/430
2006/0112521	A1	*	6/2006	Moshenrose	B25G 1/06 16/430
2008/0277558	A1	*	11/2008	Litwin	A47J 37/1295 248/637
2011/0221147	A1	*	9/2011	Hatcher	B62B 5/06 280/47.31
2014/0304929	A1	*	10/2014	Rechtin	A46B 5/0095 15/22.1

* cited by examiner

Primary Examiner — Derrick Holland

Assistant Examiner — Lauren Calve

(74) *Attorney, Agent, or Firm* — Notaro, Michalos & Zaccaria P.C.

(57) **CLAIM**

The ornamental design for a vehicle assist device, as shown and described.

DESCRIPTION

FIG. 1 is a front, left, top perspective view of a vehicle assist device showing our design therefor; FIG. 2 is a top plan view thereof; FIG. 3 is a side elevational view thereof; FIG. 4 is a front elevational view thereof; FIG. 5 is a rear elevational view thereof; and, FIG. 6 is a bottom plan view thereof. The broken lines represent unclaimed subject matter and form no part of the claimed design.

1 Claim, 6 Drawing Sheets

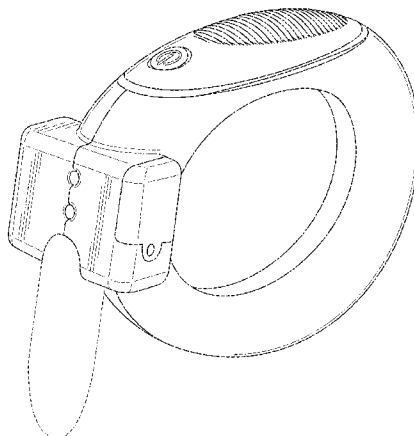

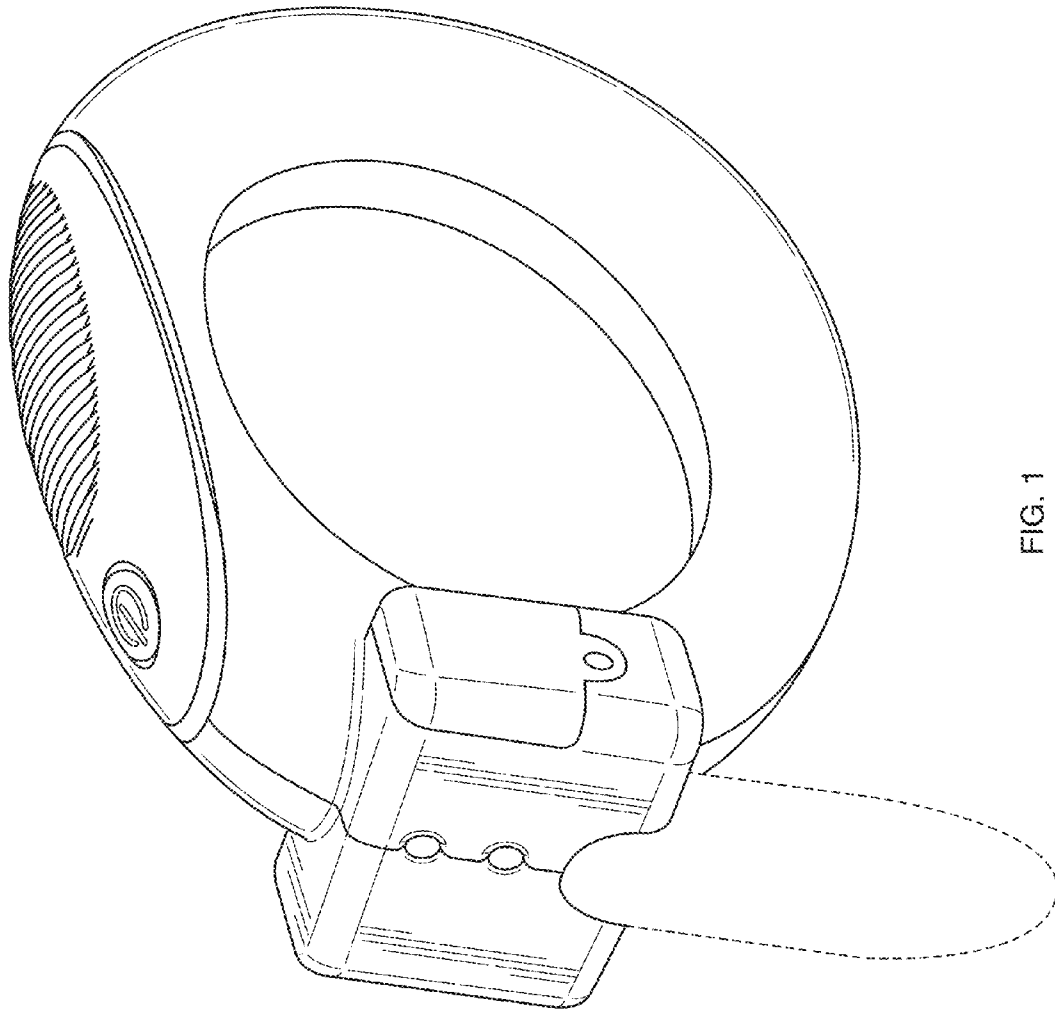

FIG. 1

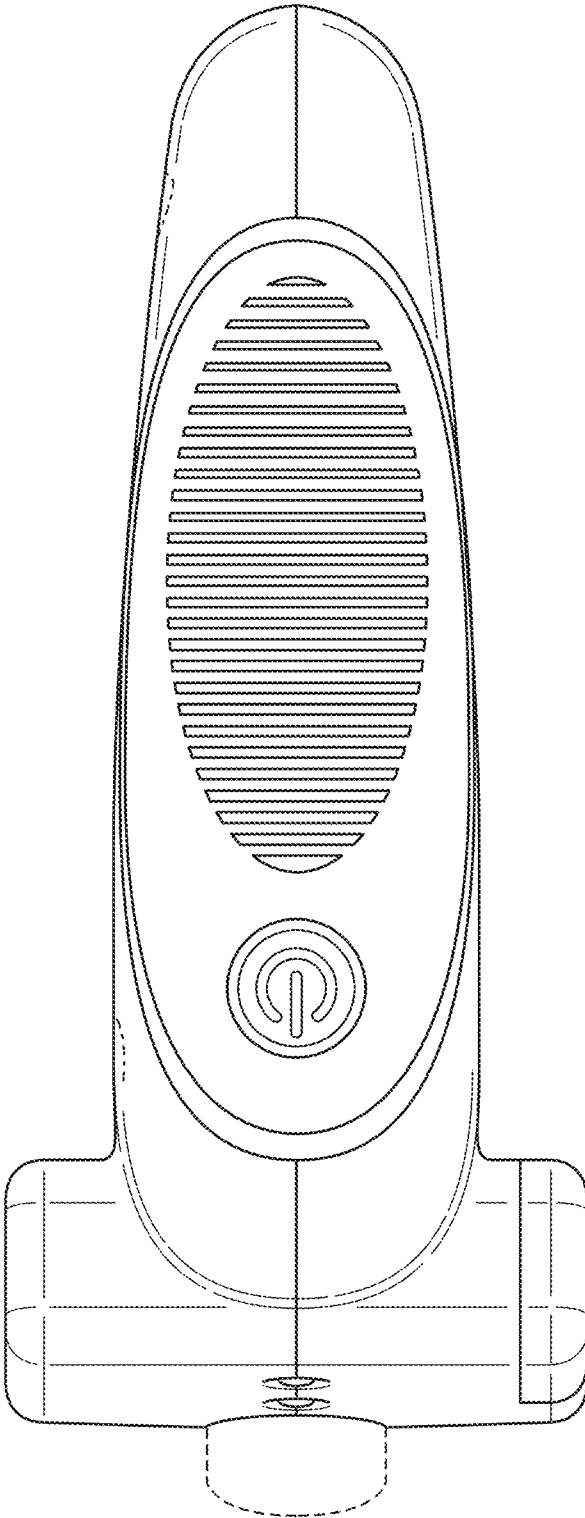

FIG. 2

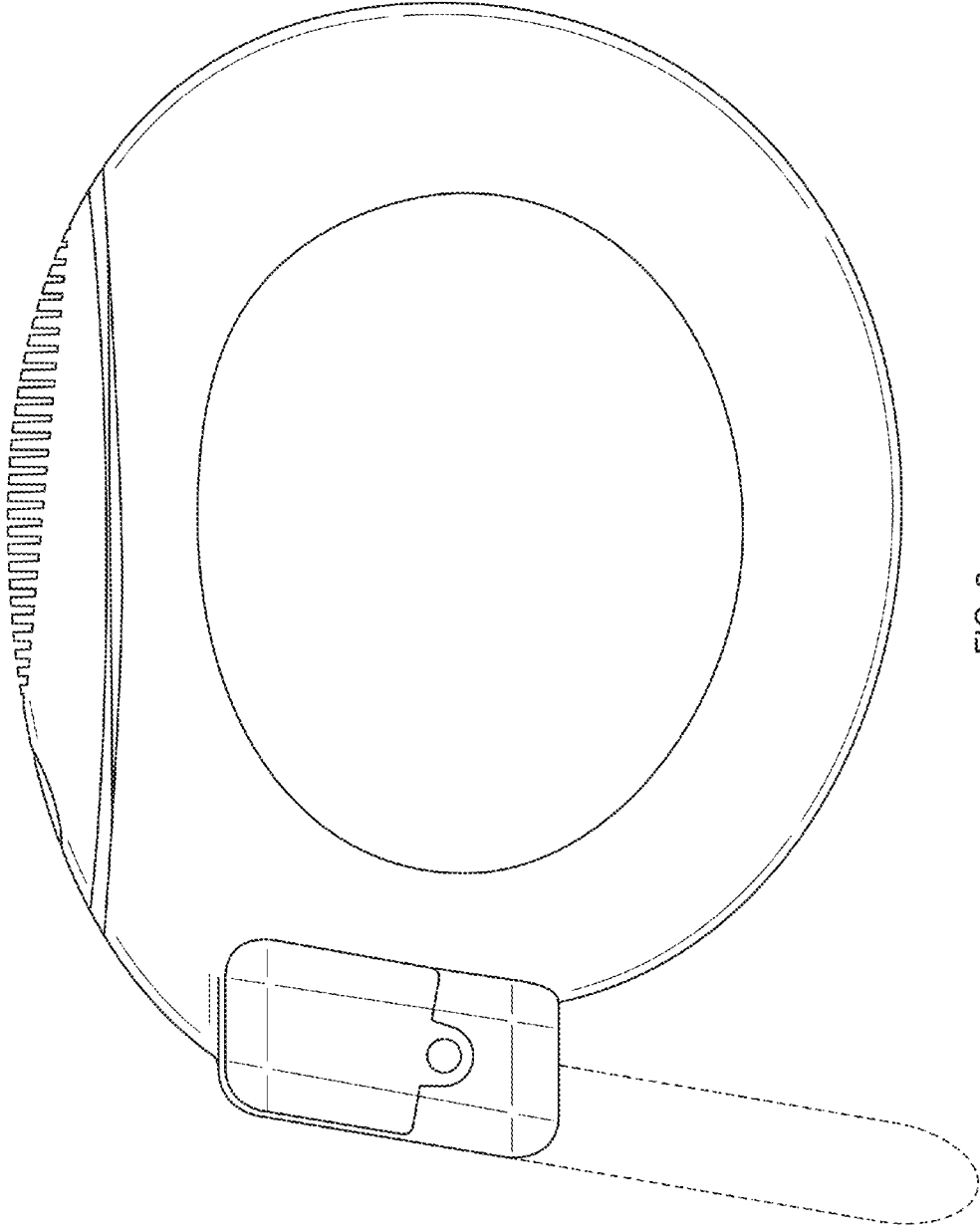

FIG. 3

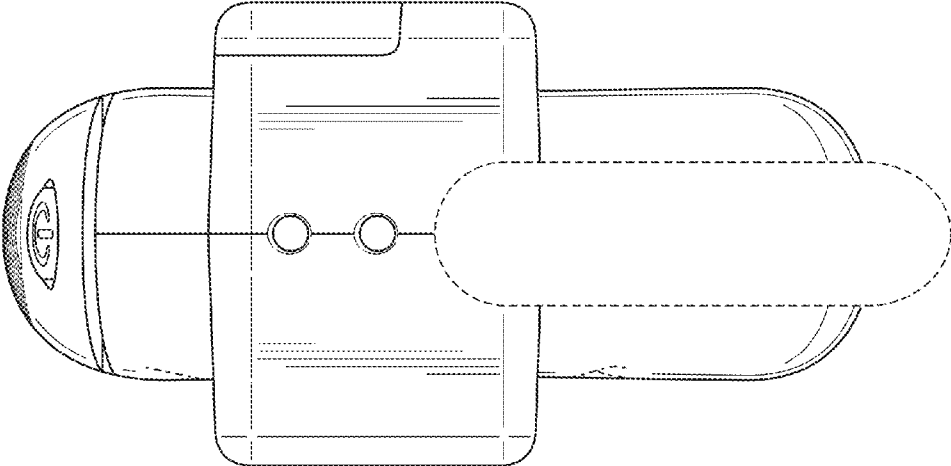

FIG. 4

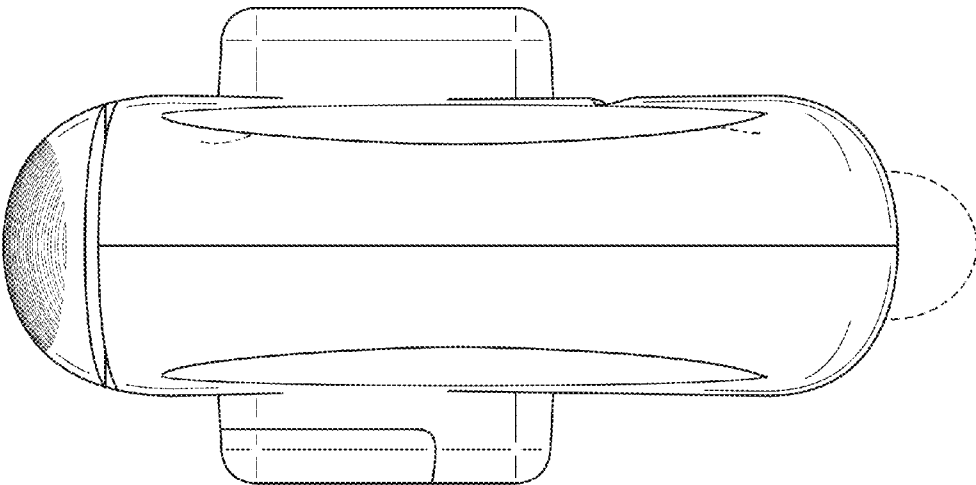

FIG. 5

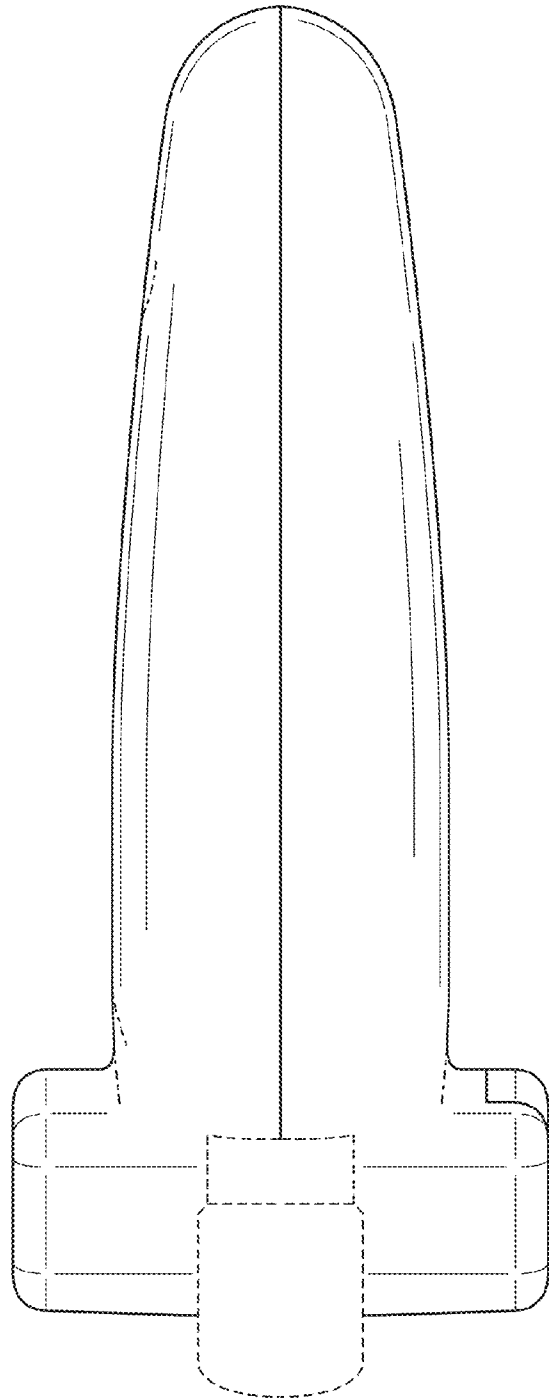

FIG. 6