

(No Model.)

W. L. MASSENGALE.
VEHICLE AXLE.

No. 524,903.

Patented Aug. 21, 1894.

FIG 1

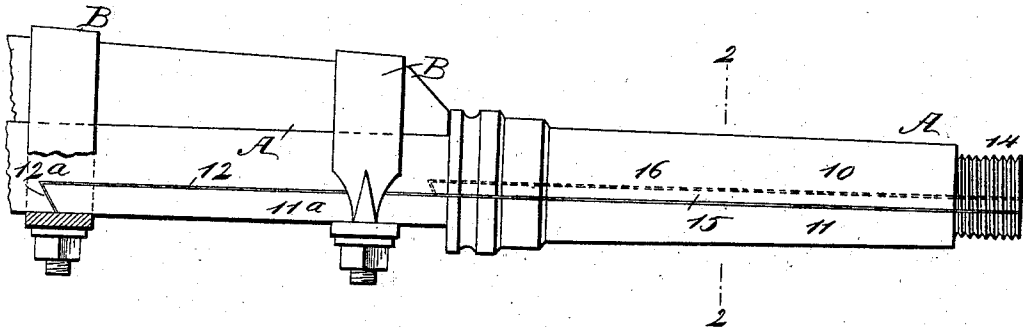
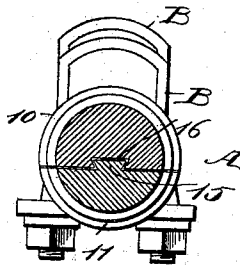

FIG 2



WITNESSES:

H. Walker
C. Sedgwick

INVENTOR

W. L. Massengale
BY *Munn & Co*

ATTORNEYS.

UNITED STATES PATENT OFFICE.

WILLIAM L. MASSENGALE, OF DEATSVILLE, ALABAMA.

VEHICLE-AXLE.

SPECIFICATION forming part of Letters Patent No. 524,903, dated August 21, 1894.

Application filed December 26, 1893. Serial No. 494,787. (No model.)

To all whom it may concern:

Be it known that I, WILLIAM L. MASSENGALE, of Deatsville, in the county of Elmore and State of Alabama, have invented a new and useful Improvement in Vehicle-Axles, of which the following is a full, clear, and exact description.

My invention relates to an improvement in vehicle axles, and it has for its object to so construct the spindles of an axle, that when the spindles are worn they may be restored to proper shape without the necessity of cutting the axle or reforging or reworking the spindle, and further to provide a means whereby the restoration of the axle may be accomplished by any person of ordinary intelligence.

The invention consists in the novel construction and combination of the several parts, as will be hereinafter fully set forth and pointed out in the claims.

Reference is to be had to the accompanying drawings, forming a part of this specification, in which similar figures and letters of reference indicate corresponding parts in both views.

Figure 1 is a side view of a portion of an axle and one of the spindles thereof; and Fig. 2 is a section taken through the spindle transversely and on the line 2—2 of Fig. 1.

In carrying out the invention the spindle A, is made in two sections, an upper section 10 and a lower section 11, the upper section being of greater thickness than the lower section; in fact the division between the two sections is made below the central longitudinal line of the spindle, as is clearly shown in Fig. 1.

The body A' of the axle of which the spindle forms a part is provided with a recess 12 at its end adjacent to the spindle, and the horizontal or upper wall of the recess 12, is in a plane with the under surface of the upper section 10 of the spindle, the recess 12 being made to extend from side to side of the body of the axle, and the recess extends through to the under face of the axle, its inner or end wall being inclined downwardly and outwardly, as shown at 12^a in Fig. 1.

The lower section 11 of the axle spindle is a counterpart in every way of the upper section 10, and said lower section is provided

with a tongue 11^a, extending from its rear end and forming a continuation of the section; and the tongue 11^a, is made of such size and shape as to completely fill the recess 12 in the body of the axle, while the under face of the tongue 11^a, will form virtually a continuation of the under face of the uncut portion of the body of the axle.

The outer end of each spindle section 10 and 11 is reduced and threaded, forming virtually a screw section 14 for the reception of the axle nut. The two sections are held together primarily through the medium of a dove-tail rib 15, formed centrally upon the upper face of the lower spindle section 11, the said dove-tail rib extending the full length of the spindle section but preferably only a slight distance over upon the tongue 11^a. This dove-tail rib 15 is made to enter a correspondingly shaped groove 16, made in the under face of the upper spindle section 10, and the inner end wall of the groove 16, is downwardly and outwardly beveled as is likewise the inner end of the dove-tail rib 15. Thus it will be observed that the beveling of the ends of the tongue 11^a, the axle recess 12^a, and the dove-tail rib 15 and its receiving groove 16, together with the character of the rib 15 and groove 16, will effectually prevent one section from leaving the other, and the lower section of the spindle is reinforced by its purchase upon the body of the axle.

In addition to the means above set forth for holding the two sections of the spindle in removable engagement, other means are used upon the body of the axle, consisting of clips B, one of which is placed upon the body of the axle near the inner end of the spindle, the said clip likewise embracing the tongue of the lower spindle section, as shown in Fig. 1, and a second clip is placed upon the axle where the tongue of the lower spindle section engages with the inner wall of the axle recess 12.

It is well known that the under surface of the axle spindle is the only surface which is worn through the action of the wheel; therefore, when this surface becomes worn to too great an extent and an axle is constructed as above set forth, the lower section 11 of the spindle need simply be removed and a new

corresponding section substituted, whereupon the axle will be restored to proper shape without the services of a blacksmith or other skilled mechanic, and the correction may be
5 made in an exceedingly short space of time.

The spindle being in two parts, friction will be materially lessened, and it is obvious that the detachable section of the spindle only will become hot, the fixed portion remaining cool;
10 therefore, this portion will not easily spring.

Having thus described my invention, I claim as new and desire to secure by Letters Patent—

1. An axle spindle, comprising an upper and
15 lower section, one section being provided with a central longitudinal dove-tail rib and the other with a dove-tail groove to receive the said rib, substantially as described.

2. In an axle, a spindle constructed in two
20 sections, one section being provided with a dove-tail rib and the other with a dove-tail groove to receive the rib, the lower section being provided likewise with a tongue adapted to enter a recess in the body of the axle, and
25 clips locking the tongue to the axle body, as and for the purpose set forth.

3. The combination, with an axle, of a spindle constructed in two sections, one section being provided with a dove-tail groove and

the other with a dove-tail rib to enter the
30 groove, the upper section forming an integral portion of the axle, the axle being provided with a recess in its under face, and a tongue integral with the under section of the spindle, shaped to fit into the axle recess, and clips
35 binding the tongue to the axle body, as and for the purpose set forth.

4. The combination, with an axle body provided with a recess in its under surface at its spindle end, the end wall of the recess being
40 inclined, of a spindle constructed in two sections, the upper section being integral with the axle body, and its under surface being flush with the upper wall of the axle recess, the said upper section being also provided
45 with a dove-tail groove the inner end of which is beveled, a dove-tail rib formed upon the lower section of the spindle, adapted to enter the dove-tail groove, a tongue constituting an
50 integral portion of the lower spindle section and fitted to enter the axle recess, and clips engaging with the body of the axle and with said tongue, substantially as set forth.

WILLIAM L. MASSENGALE.

Witnesses:

J. A. LANCASTER,
C. K. MCMORRIS.