

June 11, 1929.

W. W. KISTLER

1,717,043

LEAD AND SLUG CUTTING MACHINE

Filed March 19, 1926

2 Sheets-Sheet 1

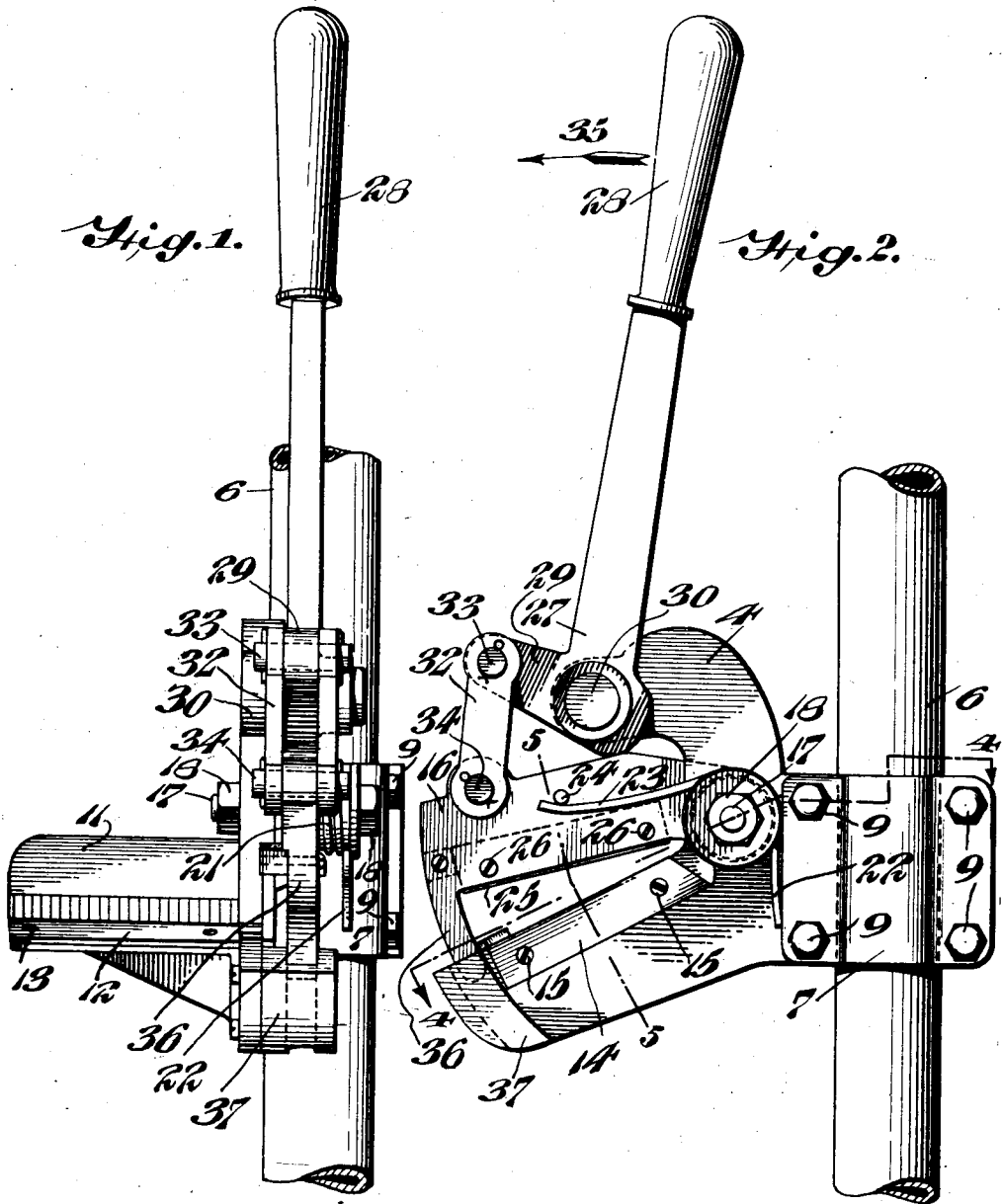

INVENTOR.

WILLIAM W. KISTLER,

BY

Mindenheim & Fairbanks
ATTORNEYS

June 11, 1929.

W. W. KISTLER

1,717,043

LEAD AND SLUG CUTTING MACHINE

Filed March 19, 1926

2 Sheets-Sheet 2

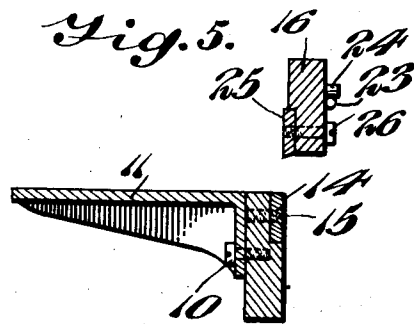
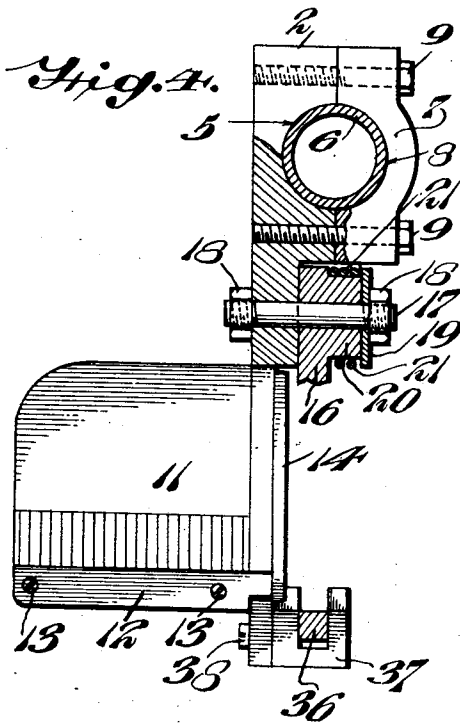
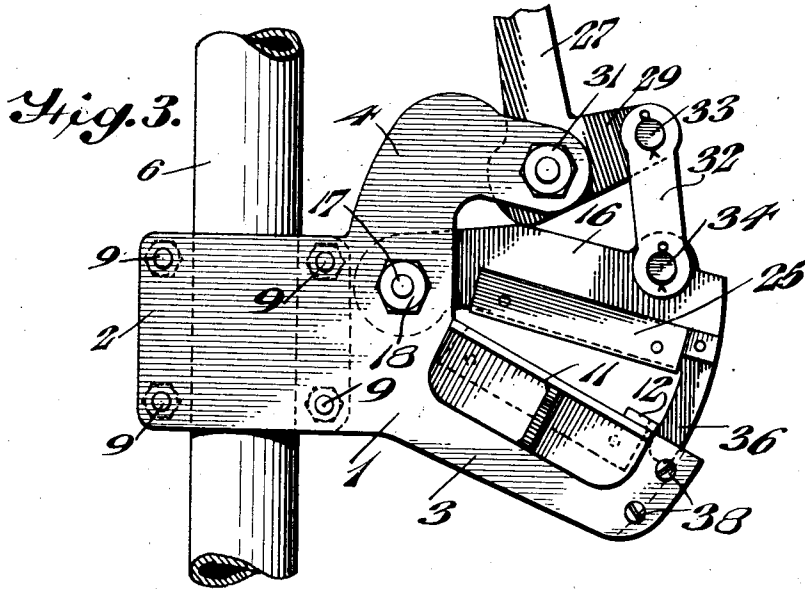

INVENTOR.

WILLIAM W. KISTLER,

BY

Wiedersheim & Fairbanks
ATTORNEYS

UNITED STATES PATENT OFFICE.

WILLIAM W. KISTLER, OF BROOKLYN, NEW YORK.

LEAD AND SLUG CUTTING MACHINE.

Application filed March 19, 1926. Serial No. 95,815.

My invention relates to a new and useful lead and slug cutting machine and it relates more particularly to a shearing device of this character, adapted to cut lead and slug and, particularly, strips of type metal.

With the above ends in view, my invention consists of a suitable stationary frame, having formed integral therewith suitable clamping means whereby the same may be secured in any convenient manner, to an upright post or standard, a table carried by said stationary frame, a movable shearing member pivotally secured to said stationary frame, an operating lever also pivotally secured to said stationary frame, shearing blades carried by said stationary frame and said movable shearing member respectively, in operative alignment with each other, and means intermediate said operating lever and said movable shearing member for actuating the latter.

For the purpose of illustrating my invention, I have shown in the accompanying drawings, forms thereof which are at present preferred by me, since they will give in practice, satisfactory and reliable results, although it is to be understood that the various instrumentalities of which my invention consists, can be variously arranged and organized and that my invention is not limited to the precise arrangement and organization of these instrumentalities as herein shown and described.

Referring to the drawings;

Figure 1 represents a front elevation of a novel lead and slug cutting machine embodying my invention.

Figure 2 represents a side elevation of the same.

Figure 3 represents a side elevation, similar to that shown in Figure 2, viewed from the opposite side.

Figure 4 represents a section on line 4—4 of Figure 2.

Figure 5 represents a section on line 5—5 of Figure 2.

Referring to the drawings, in which like reference characters indicate like parts, 1 designates the frame of my novel device, comprising the laterally projecting clamping member 2, the downwardly inclined stationary shearing member 3, and the upper stationary lever arm or bracket 4. The clamp 2 is provided with a vertical semi-circular channel or recess 5, adapted to fit an upright standard 6, upon which the device is mount-

ed; while a similar clamp member 7, also having a semi-circular channel therein, is adapted to be secured to the member 2, by means of the bolts 9, thereby rigidly to clamp the machine onto the said upright standard or support 6.

A laterally projecting inclined table 11 is secured to one side of the stationary lower shearing member 3, by means of screws 10, and is provided with a guide or retaining strip 12 secured to the lower edge thereof, by means of the screws 13, and extending at a right angle to the shearing edge. On the other side of the stationary shearing member 3, and near the upper end thereof, a stationary shearing blade 14 is set in, as shown particularly in Figure 5, and is secured rigidly in the rabbeted upper edge of said stationary shearing member 3, flush with said upper edge and with said table 11, by means of the screws 15.

The upper movable shearing member 16, is pivotally secured to one side of the frame 1, by means of the bolt 17, the nuts 18, and the washer 19, as shown particularly in Figure 4, in operative alignment with the lower stationary shearing member 3. The upper or movable shearing member 16 is provided with a boss or lateral projection 20, in order to provide a better bearing surface for the pivot bolt 17. A spiral spring coil 21 is wound about said boss, and has one of the free ends 22 thereof abutting the clamping member 2, and having the other free end 23 thereof engaging a pin 24, which is fixed in the upper shearing member 16. The spring 21 therefore constantly urges the upper movable shearing member 16 in an upward direction and away from the lower stationary shearing member 3. The upper stationary shearing member is also provided with a shearing blade 25, which is similarly set into the lower rabbeted edge of the upper shearing member 16, and in operative alignment with the lower shearing blade 14, and secured thereto by means of the screws 26.

A bell-crank lever 27, having the long operating handle or lever 28, and the shorter arm 29, is pivotally secured to the overhanging lever bracket 4, by means of the pivot bolt 30 and the nut 31. The arm 29 of the bell crank 27 is in turn operatively connected with the movable shearing member 16, by means of a pair of links 32, pivotally secured to the end of the arm 29 and the outer end of the movable shearing member 16, at its two

ends respectively, by means of the pivot pins 33 and 34. Thus, a forward and downward deflection of the lever or operating handle 28, in the direction of the arrow 35 will cause the upper movable shearing member 16 also to be deflected downwardly, thereby to coact with the lower shearing member 3.

In order to support and guide the outer free end of the upper movable shearing member 16, against lateral thrust, occasioned by the shearing operation, and in order to insure a clean cut surface and edge, without the formation of any burr, there is provided upon the outer end of the upper movable shearing member 16, a downwardly projecting arcuate guide tongue 36, secured thereto or formed integral therewith, and having its center at the pivot point of said upper movable shearing member. A corresponding arcuate guide channel member 37 is secured to the outer end of the lower stationary shearing member 3, by means of the screws 38, in operative alignment with said tongue 36; said guide channel being adapted to receive said tongue 36 and to guide the same, thereby to provide lateral support for the free end of the pivoted movable shearing member 16.

It will now be apparent that I have devised a novel and useful construction of a lead and slug cutting machine which embodies the features of advantage enumerated as desirable in the statement of the invention and the above description and while I have in the present instance, shown and described a preferred embodiment thereof which will give in practice satisfactory and reliable results it is to be understood that such embodiment is susceptible of modification in various particulars without departing from the spirit or scope of the invention or sacrificing any of its advantages.

Having thus described my invention, what I claim as new and desire to secure by Letters Patent is:—

1. In a device of the character stated, a stationary frame, a forwardly and downwardly inclined stationary shearing member carried thereby, a movable shearing member pivotally secured to said frame, an actuating lever pivotally secured to said frame, means intermediate said lever and said movable shearing member for actuating the latter, a laterally projecting table carried by said sta-

tionary shearing member, having its upper surface flush with the upper edge of said shearing member, an arcuate guide tongue fixed to the free end of the upper movable shearing member, an arcuate guide channel member fixed to the stationary lower shearing member for guiding said tongue, a shearing blade detachably secured to each of the opposed edges of said stationary and movable shearing member respectively, and means to urge said movable shearing member upwardly into the open position.

2. In a device of the character stated, a frame, a clamp carried thereby for securing the same to a suitable support, a lower stationary shearing member carried by said frame, an upper movable shearing member pivotally secured to said frame in operative alignment with said lower stationary shearing member, a lower and upper shearing blade detachably secured to the stationary and movable shearing members respectively, in operative alignment with each other, an arcuate guide tongue carried by the outer free end of said movable shearing member, an arcuate stationary guide carried by the outer end of said stationary shearing member adapted to receive and guide said tongue, a laterally extending table carried by said lower stationary shearing member having its upper surface flush with the upper edge of the same, an actuating bell crank lever pivotally secured to said frame, an actuating link interconnecting one arm of said bell crank lever with said movable shearing member, and a spring adapted to urge said upper movable shearing member upwardly into the open position.

3. A device of the character stated comprising a fixed frame, a stationary lower shearing member carried thereby, an arcuate guide of channel cross-section fixed to said lower shearing member, a movable upper shearing member pivotally secured to said frame, an arcuate tongue of rectangular cross-section fixed to the free end of said movable shearing member for travel within said guide, an actuating lever pivotally secured to said frame, and a pair of links pivotally connecting said actuating lever and said upper movable shearing member.

WILLIAM W. KISTLER.