

A. E. SHANNON.
TRAMWAY SWITCH.

No. 600,091.

Patented Mar. 1, 1898.

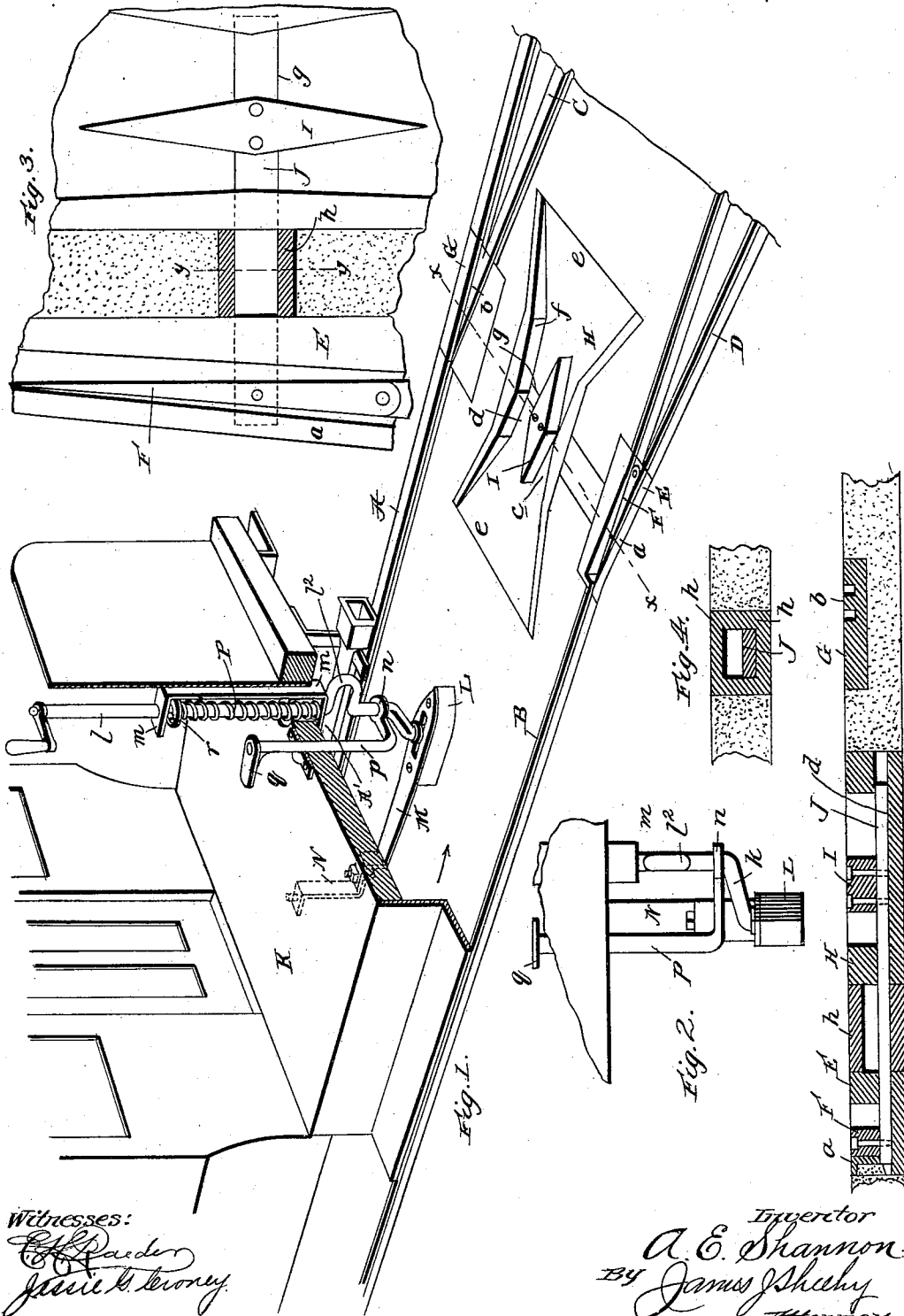

Witnesses:
Edw. Pardon
James H. Koney

Inventor
A. E. Shannon
By *James Sheehy*
Attorney

(No Model.)

2 Sheets—Sheet 2.

A. E. SHANNON.
TRAMWAY SWITCH.

No. 600,091.

Patented Mar. 1, 1898.

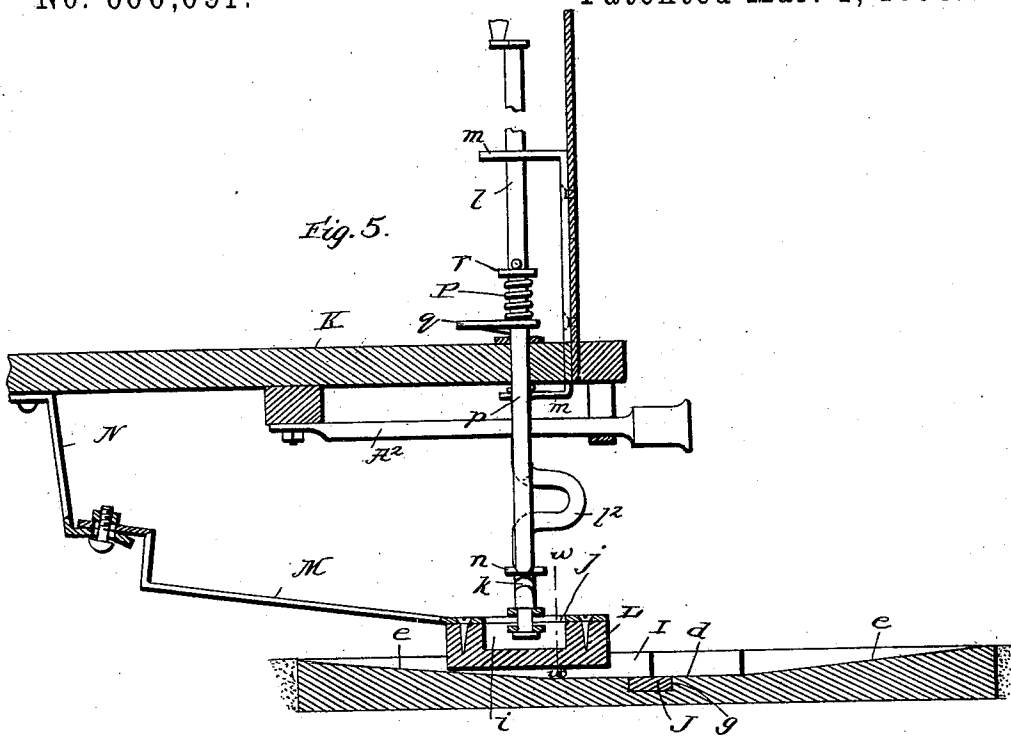

Fig. 5.

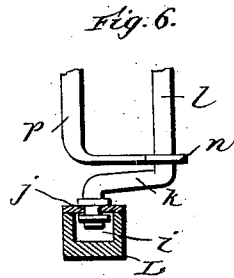

Fig. 6.

Witnesses:
Chas. Rader
Justus H. Leroy

Inventor
A. E. Shannon
 BY *James Shuchy*
 Attorney

UNITED STATES PATENT OFFICE.

ADAM EMERY SHANNON, OF FINDLAY, OHIO.

TRAMWAY-SWITCH.

SPECIFICATION forming part of Letters Patent No. 600,091, dated March 1, 1898.

Application filed June 29, 1897. Serial No. 642,880. (No model.)

To all whom it may concern:

Be it known that I, ADAM EMERY SHANNON, a citizen of the United States, residing at Findlay, in the county of Hancock and State of Ohio, have invented certain new and useful Improvements in Tramway-Switches; and I do declare the following to be a full, clear, and exact description of the invention, such as will enable others skilled in the art to which it appertains to make and use the same.

My invention relates to tramway-switches, and among other things it contemplates the provision of a simple and efficient track device connected with a movable switch-point and a simple and efficient car device for engaging and moving the track device, and consequently the switch-point, while the car is in motion, the track device being so formed and arranged that it is adapted to be engaged and moved by the car device irrespective of the direction in which the car is traveling, and the car device being so connected with the car that it may be adjusted to move the track device in either direction or to clear the same, as desired.

The invention will be fully understood from the following description and claims when taken in conjunction with the annexed drawings, in which—

Figure 1 is a perspective view illustrating a portion of a track and a car thereon embodying my invention. Fig. 2 is a detail transverse section taken in the plane indicated by the line *x x* of Fig. 1, illustrating the car device or shoe at its normal height. Fig. 3 is a detail plan view of a portion of the track with a part in section. Fig. 4 is a section taken in the plane indicated by the line *y y* of Fig. 3. Fig. 5 is a detail longitudinal section illustrating the car and car device with its appurtenances together with a portion of the track, and Fig. 6 is a detail section on line *w w* of Fig. 5.

In the said drawings similar letters designate corresponding parts in all of the several views, referring to which A B indicate main-track rails, and C D indicate turnout-rails, all of which are preferably arranged flush with the pavement or roadway in which they are laid, as shown, so as to offer no obstruction.

E indicates a frog which is interposed be-

tween the sections of the main-track rail B and has a fixed track portion *a* for connecting one section of the rail B and the turnout-rail D, and also has a pivoted tongue or point F. G indicates a frog interposed between the sections of the main-track rail A and having a fixed tongue *b*, forming the terminal or point of the turnout-rail C, and H indicates a plate or casting, which for convenience I will term the "switch-plate." This switch-plate H is laid in the road-bed between the frogs E G so that its upper side will be flush with the surface of said road-bed, and it is recessed, as indicated by *c*, and has the bottom of said recess horizontal at its middle, as indicated by *d*, and inclined at its ends to the surface of the road-bed, as indicated by *e*, while its side walls *f* are beveled and flared outwardly, as shown, for a purpose presently described.

I indicates the laterally-movable track device, which is arranged on the horizontal portion of the bottom of the recess *d* in the plate H and is of elongated diamond shape, as shown. This track device I is connected to a transverse movable bar J, and this bar J, which rests snugly in a groove *g* in the switch-plate and extends through a box *h* between the switch-plate and frog E, so as to prevent its being rendered inoperative by ice or snow, is connected in turn with the switch-point F, whereby it will be seen that when the track device is moved laterally the switch-point will be moved in a corresponding direction.

K indicates a street-car of the ordinary or any other suitable construction, and L indicates a shoe or car device which is designed to engage and move the track device I, and consequently the switch-point, while the car is in motion. This car device L is disposed longitudinally and has its forward end beveled, and in the preferred embodiment of my invention it is fixedly connected to a strap M, which in turn is loosely connected at its rear end to a hanger N on the bottom of the car in such a manner as to permit of its forward end being swung laterally and moved up and down for a purpose presently described. The shoe L is provided in its upper side with a recess *i*, and the portion of the strap M which covers said recess is provided with an elongated slot *j*, as shown. Through this slot *j* and into the recess *i* extends the terminal of

a crank-arm k at the lower end of a shaft l , which terminal has a head at its lower end to hold it to the shoe and also has washers above and below the strap M to ease its movements in the slot thereof. The crank-shaft l extends loosely through an opening in the car-platform and is journaled above and below the same in brackets m and is also journaled in an arm n of a vertically-movable rod p , which extends through the platform and is provided above the same with a pedal q , as shown. A coiled spring P surrounds the crank-shaft l and is interposed between the lower bracket m and a collar r on the shaft, whereby it will be seen that the crank-shaft, the vertically-movable rod p , and the shoe or car device L will be normally held in the position shown in Fig. 1. In this position the car device L would pass over and not engage the track device I , and in consequence it will be observed that if the switch is set to guide the car in the desired direction the car may travel over the switch without the car device engaging the track device.

The switch is shown in Fig. 1 as set for a clear main track, and if the motorman on the car traveling in the direction indicated by arrow desires to take his car on the turnout it is simply necessary for him to turn the shaft l , so as to move the shoe L toward the right, and when the shoe reaches the switch-plate depress the same by pressing with his foot on pedal q . When this is done, the shoe L will be guided by the incline e and side wall f of the recess in the switch-plate H into engagement with the right side of the track device I , and in consequence said track device and the switch-point will be moved toward the left and the car-wheels when they reach the switch-point will be guided on the turnout-rails. If the switch be set for the turnout and it is desired to continue on the main track, the car device on the car moving in the direction of arrow is adjusted to engage the left side of the track device I .

The track device I is also adapted to be engaged at either side by a car device on a car moving on the main track or turnout in the direction opposite to that indicated by arrow, and consequently it will be seen that if the switch is set for the turnout it may be moved to the clear-main-track position by a car moving on the main track in the direction opposite to that indicated by arrow, and if said switch is set for the clear main track it may be moved to the turnout position by a car moving on the turnout in the direction opposite to that indicated by arrow.

From the foregoing it will be appreciated that my improved switch is especially adapted for embodiment in street-railways, inasmuch as it offers no obstruction in the street and is adapted to be operated without the necessity of stopping the cars. Said switch may, however, be embodied in railways other than those laid in the streets of cities, in which case the switch-plate H may be omitted. The frogs

$E G$ may also in some cases be omitted and only a switch-point employed.

With all of its advantages it will be observed that my improved switch is very simple and efficient in operation and that it embodies no complicated parts that are likely to get out of order after short use, which is an important advantage.

When my improvements are placed on cars having draw-heads at their ends above their floors, the rod l may be and preferably is straight from the crank k to the hand-crank at its upper end. When, however, the improvements are placed on cars having pivoted draw-bars, as A^2 , the rod l is provided at an intermediate point of its length with the lateral loop l^2 . This loop, when the shaft l is drawn up so that the mouth of the loop rests in the same horizontal plane as the draw-bar A^2 and the loop is disposed at right angles to said bar with its mouth contiguous to the same, permits free movement of the draw-bar in a horizontal plane and consequently prevents the shaft l from interfering with the movements of the draw-bar when the cars are taking a curve.

Having described my invention, what I claim, and desire to secure by Letters Patent, is—

1. In a tramway-switch, the combination with main-track rails, turnout-rails, a movable switch-point, and a longitudinally-disposed track device arranged between the track-rails and connected with the switch-point; of a car, a shoe loosely connected with the car and movable in a vertical plane and also in a horizontal plane so as to permit of its being depressed and arranged to engage either side of the track device, a crank-shaft journaled on the car and having an arm connected with the shoe, a spring acting against said shaft for normally holding the shoe in its raised position, and a pedal-rod loosely receiving the crank-shaft above its arm, substantially as specified.

2. In a tramway-switch, the combination with main-track rails, turnout-rails, a movable switch-point, and a longitudinally-disposed track device arranged between the track-rails and connected with the switch-point; of a car, a shoe loosely connected with the car and movable in a vertical plane and also in a horizontal plane so as to permit of its being depressed and arranged to engage either side of the track device, a spring for normally holding the shoe in its raised position, a pedal device connected with the shoe and adapted for use in depressing the same, and a hand device connected with the shoe and adapted for use in moving the same in a horizontal plane, substantially as specified.

3. In a tramway-switch, the combination with main-track rails, turnout-rails, a movable switch-point, a longitudinally-disposed track device arranged between the track-rails and beveled toward its opposite ends, and a bar connecting the track device and switch-

point; of a car, the shoe having a recess in its upper side, the strap connected to the shoe and loosely connected to a hanger on the car and having a slot communicating with the recess in the shoe, the crank-shaft journaled in brackets above and below the platform of the car and having the crank-arm terminating in the end extending through the slot in the strap and secured in the recess in the shoe, a coiled spring surrounding the crank-shaft and interposed between the lower bracket and a collar on said shaft and the vertically-movable rod extending loosely through the platform of the car and having the pedal at its upper end and the eye at its lower end loosely receiving the crank-shaft, substantially as specified.

4. The combination of a car, the shoe having a recess in its upper side, the strap connected to the shoe and loosely connected to a hanger on the car and having a slot communicating with the recess in the shoe, the crank-shaft journaled in brackets above and below the platform of the car and having the crank-arm terminating in the end extending through the slot in the strap and secured in the recess in the shoe, a coiled spring surrounding the crank-shaft and interposed between the lower bracket and a collar on said shaft, and the vertically-movable rod extend-

ing loosely through the platform of the car and having the pedal at its upper end and the eye at its lower end loosely receiving the crank-shaft, substantially as specified.

5. The combination of a car, the shoe having a recess in its upper side, the strap connected to the shoe and loosely connected to a hanger on the car and having a slot communicating with the recess in the shoe, the crank-shaft journaled in brackets above and below the platform of the car and having the crank-arm terminating in the end extending through the slot in the strap and secured in the recess in the shoe, and also having the lateral loop at an intermediate point of its length, a coiled spring surrounding the crank-shaft and interposed between the lower bracket and a collar on said shaft, and the vertically-movable rod extending loosely through the platform of the car and having the pedal at its upper end and the eye at its lower end loosely receiving the crank-shaft, substantially as specified.

In testimony whereof I affix my signature in presence of two witnesses.

ADAM EMERY SHANNON.

Witnesses:

R. F. CHRISTY,
LEVI NEISWANGER.