

**(12) PATENT**  
**(19) AUSTRALIAN PATENT OFFICE**

**(11) Application No. AU 199872990 B2**  
**(10) Patent No. 745441**

(54) Title  
**Swabbable luer-coned valve**

(51)<sup>7</sup> International Patent Classification(s)  
**A61M 039/26**

(21) Application No: **199872990**

(22) Application Date: **1997.11.13**

(87) WIPO No: **WO98/22178**

(30) Priority Data

| (31) Number      | (32) Date         | (33) Country |
|------------------|-------------------|--------------|
| <b>60/031175</b> | <b>1996.11.18</b> | <b>US</b>    |
| <b>60/034708</b> | <b>1997.01.03</b> | <b>US</b>    |

(43) Publication Date : **1998.06.10**

(43) Publication Journal Date : **1998.08.06**

(44) Accepted Journal Date : **2002.03.21**

(71) Applicant(s)  
**Nypro, Inc.**

(72) Inventor(s)  
**Andrew L. Cote Sr.**

(74) Agent/Attorney  
**GRIFFITH HACK,GPO Box 1285K,MELBOURNE VIC 3001**

(56) Related Art  
**CA 2175021**  
**US 4334551**  
**WO 96/00107**



|  |                  |  |
|--|------------------|--|
| <p>(51) International Patent Classification<sup>6</sup> :<br/> <b>A61M 39/26</b></p>   | <p><b>A1</b></p> | <p>(11) International Publication Number: <b>WO 98/22178</b><br/>         (43) International Publication Date: 28 May 1998 (28.05.98)</p>  |
| <p>(21) International Application Number: PCT/US97/20790<br/>         (22) International Filing Date: 13 November 1997 (13.11.97)<br/>         (30) Priority Data:<br/>             60/031,175           18 November 1996 (18.11.96)   US<br/>             60/034,708           3 January 1997 (03.01.97)     US<br/>         (71) Applicant (for all designated States except US): NYPRO, INC. [US/US]; 101 Union Street, Box 2005, Clinton, MA 01501-2005 (US).<br/>         (72) Inventor; and<br/>         (75) Inventor/Applicant (for US only): COTE, Andrew, L., Sr. [US/US]; 1 Linden Way, Merrimack, NH 03054 (US).<br/>         (74) Agents: SUNSTEIN, Bruce, D. et al.; Bromberg and Sunstein LLP, 125 Summer Street, Boston, MA 02110-1618 (US).</p> |                  | <p>(81) Designated States: AL, AM, AT, AU, AZ, BA, BB, BG, BR, BY, CA, CH, CN, CU, CZ, DE, DK, EE, ES, FI, GB, GE, GH, HU, IL, IS, JP, KE, KG, KP, KR, KZ, LC, LK, LR, LS, LT, LU, LV, MD, MG, MK, MN, MW, MX, NO, NZ, PL, PT, RO, RU, SD, SE, SG, SI, SK, SL, TJ, TM, TR, TT, UA, UG, US, UZ, VN, YU, ZW, ARIPO patent (GH, KE, LS, MW, SD, SZ, UG, ZW), Eurasian patent (AM, AZ, BY, KG, KZ, MD, RU, TJ, TM), European patent (AT, BE, CH, DE, DK, ES, FI, FR, GB, GR, IE, IT, LU, MC, NL, PT, SE), OAPI patent (BF, BJ, CF, CG, CI, CM, GA, GN, ML, MR, NE, SN, TD, TG).</p> <p><b>Published</b><br/> <i>With international search report.</i><br/> <i>Before the expiration of the time limit for amending the claims and to be republished in the event of the receipt of amendments.</i></p> |

(54) Title: SWABBABLE LUER-CONED VALVE

(57) Abstract

A normally closed valve that may be opened upon insertion of a nozzle permits two-way flow when opened by a luer-taper nozzle. The valve also is able to resist large back pressure. The valve includes a substantially rigid housing that defines a passageway having an inlet section and an outlet section. The housing has an exterior inlet face to which the inlet section opens. The inlet section preferably has tapered and expanding zones. The tapered zone is adjacent to the exterior inlet face and is shaped to receive the nozzle. The expanding zone is adjacent to the tapered zone and has a larger inner diameter than the tapered zone's inner diameter. The exterior of the inlet section of the housing may have threads to accept luer-lock threads that may surround the nozzle.

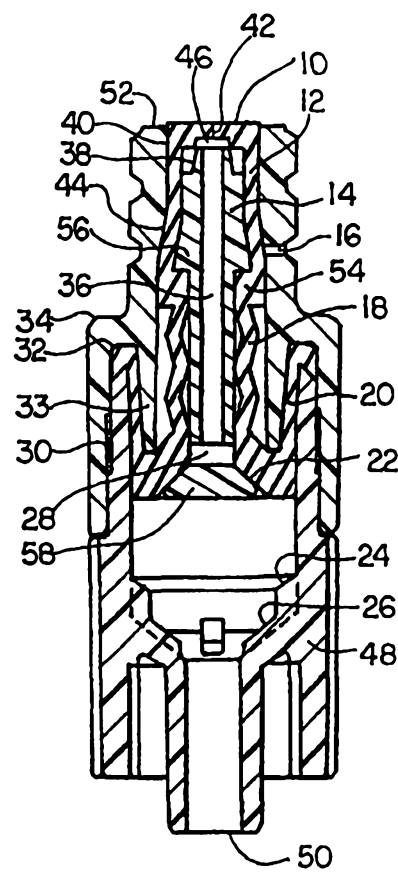

SWABBLE LUER-CONED VALVE

TECHNICAL FIELD

5           The present invention relates to valves that may be actuated by nozzles and in particular by male Luer fittings.

SUMMARY OF THE INVENTION

10

          The present invention is directed to a normally closed valve that may be opened upon insertion of a nozzle, which in a preferred embodiment is a male Luer fitting. The valve comprising: a housing defining a passageway having an inlet section and an outlet section, the housing being substantially rigid and having an exterior inlet face to which the inlet section opens; a substantially rigid cannula disposed within the passageway and extending into the inlet section, the cannula being  
15           movable within the housing between first and second positions corresponding to closed and open modes of the valve, the cannula having an inlet end and an outlet end; a substantially flexible, resilient gland member having a seal section disposed over the inlet end of the cannula, the seal section having a normally closed aperture  
20           therethrough, a tubular section connected to the seal section and disposed around the cannula between cannula and the housing, and an attachment section connected to the tubular section and attached to the housing; wherein,  
30           when the valve is in its closed mode, the seal section is substantially aligned with the exterior inlet face of the housing so as to provide a swabbable surface, the gland and cannula cooperating when in the closed mode to seal the valve.

35

          The inlet end of the cannula and the gland are preferably shaped so as to permit the gland's seal section to move with respect to the cannula. Preferably, the valve includes



means for limiting this movement of the seal section, for example by including a step on either the cannula's inlet end or the inner diameter of the gland. The inlet end of the cannula may be shaped to urge the seal section open when nozzle presses the seal section against the inlet end of the cannula while the seal section is in the expanding zone of the housing inlet section. In a preferred embodiment, a space is provided between the seal section and the cannula when the valve is in the closed position.

When the valve is in its closed mode, the seal section is substantially aligned with the exterior inlet face of the housing so as to provide a swabbable surface; preferably the seal section extends a small amount beyond the exterior inlet face so as to ensure that the seal section surface is fully swabbable. Preferably, the outlet end of the cannula is shaped so as to provide a back-pressure seal with the attachment section of the gland member.

In a preferred embodiment, the attachment section of the gland member is stretched as the valve is urged by the nozzle from the valve's closed mode to the valve's opened mode. In addition, the tubular section of the gland member is preferably compressed as the valve is urged by the nozzle from the valve's closed mode to the valve's opened mode. In an alternative embodiment, the outlet end of the cannula is shaped (e.g., as a leaf spring) to provide a flexible member that urges the cannula into the first position.

The housing preferably includes gland-stopping structure for stopping movement of the gland towards the outlet section of the valve independently of movement of the cannula. Cannula-stopping structure may also be provided, on the housing or on the cannula's outlet end, for stopping movement of the cannula towards the outlet section of the valve while permitting flow to the outlet section of the valve.

These and other features, aspects and advantages of the present invention will become better understood with regard to the following description taken in conjunction with the accompanying drawings wherein are set forth, by way of illustration and example, certain embodiments of this invention.

#### Brief Description of the Drawings

FIG. 1 shows a longitudinal sectional view of a valve according to one embodiment of the invention.

FIGS. 2-6 show longitudinal sectional views of the valve shown in FIG. 1, as the valve is urged by a luer-taper nozzle from a fully closed position to a fully open position.

FIGS. 7-9 show longitudinal section views of three alternative embodiments of the gland that may be used in the valve shown in FIG. 1.

5 FIG. 10 shows an alternative embodiment of the invention in the closed position.

FIG. 11 shows a variation of the FIG. 10 embodiment in the open position.

FIG. 12 shows a another alternative embodiment of the invention.

FIG. 13 shows a variation of the FIG. 1 embodiment.

FIG. 13A shows a cross section of the FIG. 13 embodiment.

10 FIGS. 14A-14C shows how the gland's seal section opens in response to a nozzle being inserted into the valve.

FIG. 15 shows a longitudinal sectional view of a valve according to another embodiment of the invention.

15 FIGS. 16A-16D show longitudinal sectional views of the valve shown in FIG. 15, as the valve is urged by a luer-taper nozzle from a fully closed position to a fully open position.

FIGS. 16E-16G show end views of the seal section of FIGS. 16D-16D respectively.

20 FIG. 17 shows a longitudinal sectional view of a valve according to another embodiment of the invention.

FIGS. 18A-18D show longitudinal sectional views of the valve shown in FIG. 17, as the valve is urged by a luer-taper nozzle from a substantially fully closed position to a substantially fully open position.

### 25 Detailed Description of Specific Embodiments

As shown in FIG. 1, in a preferred embodiment of the invention, the valve is made from four components: an inlet housing portion 34, an outlet housing portion 48, a gland 12 and a movable, rigid interior cannula 14. The two housing portions preferably are ultrasonically shear welded together at area 30, so as to form an integral housing and so as  
30 to hold one end of the gland 12 in a gland-retention area 32. Fluid passing through the

valve passes through the cannula 14, which is located within the gland 12, which in turn is located within the housing.

The gland 12 has three sections: a swabbable seal section 10, a tubular section 18 and an attachment section 20. Preferably, the valve is made from silicone. The seal section 10 has an aperture 42 passing through it; the aperture 42 may be, for example, a pierced hole or a slit. When the valve is in the closed mode, as shown in FIG. 1, the aperture 42 is held closed by the inner surface of the housing; the inner diameter of the housing at the inlet is smaller than the outer diameter of the seal section 10 of the gland 12, so that the housing squeezes the seal section 12, thereby forcing the aperture 42 closed. This compression zone 40 of the passageway through the housing is tapered to accept and hold a luer-tapered nozzle (item 60 in FIG. 2). Further down the housing's passageway a second zone 44 has an inner diameter that is greater than that of the tapered, compression zone 40 and greater than the outer diameter of the seal section 10, so that the seal section may expand when it is forced into this zone, thereby permitting the aperture 42 to open. The inlet housing portion 34 preferably includes a vent 16 to ease the movement of the seal section 10 between the expanding zone and the tapered zone. When the valve is in the fully closed position, the gland's seal section 10 is flush with or extends slightly above the exterior inlet face 52 of the housing. The seal section 10 and the exterior inlet face 52 thus present a swabbable surface, i.e., they may be easily wiped clean with an alcohol swab, for instance.

The tubular section 18 of the gland 12 is preferably designed to be compressible. Another section 54 of the gland 12, located between the seal section and the compressible, tubular section may be shaped to match a corresponding ledge 56 on the cannula 14, so as to hold the top section of the gland 12 in place on the cannula.

In addition to the seal section 10 of the gland 12, the valve has a second seal area 22 at the outlet end of the cannula 14. The outlet end 58 of the cannula 14 is shaped so as to provide a seal against the gland 12. The cannula's outlet end 58 has a wider outer diameter than the inner diameter of the compressible, tubular section 18 of the gland, and the fluid passageway 36 through the cannula has a channel 28 that redirects the passageway sideways into the gland 12. This arrangement forms a seal when the valve is in the closed position, as shown in FIG. 1, and is able to resist a large amount of back

pressure from the outlet end 50 of the valve. The inlet housing portion 34 preferably includes a rigid annular extension 33 that separates the gland's tubular section 18 from the gland's attachment section 20. This annular extension 33 ensures that the tubular and attachment sections of the gland 12 do not fold incorrectly when the valve is opened and closed. In addition, the annular extension 33, in connection with the gland, ensures that the cannula's outlet section 58 does not get forced too far up into the inlet section by a large amount of back pressure. The annular extension 33 also prevents the lower portion of the gland 12 from being forced too far up into the inlet section. Since the valve has a second seal area 22, formed by the cannula's outlet end 58, that is able to resist large back pressures, the first seal--the aperture 42 through the gland's seal section 10--does not have to resist large back pressures.

Preferably, the gland's tubular section 18 is preloaded, by making the gland's tubular section sufficiently long with respect to the distance between the cannula's ledge 56 and the cannula's outlet end 58, so that the gland's tubular section is under compression even when the valve is in the closed position. This arrangement improves the effectiveness of the second seal area 22. By preloading the gland's tubular section 18, the valve is made more resistant to opening in response to either a positive pressure or a negative pressure applied to the outlet 50. By having a sufficient amount of surface area of the gland 12 exposed to the outlet 50 with respect to the surface area of the cannula 14 exposed to the outlet, the effect on a closed valve of a negative pressure at the outlet will be to pull the gland toward the outlet along with the cannula 14. By having a negative pressure pull both the gland 12 and the cannula 14 toward the outlet, the second seal area 22 remains sealed.

The cannula's outlet end 58 may be made thin, so that in an emergency a needle--instead of a luer-taper nozzle--may be used with the valve. The needle may be inserted through the seal section's aperture 42 through the cannula's passageway, and then, if the outlet end 58 is made thin enough, the needle may pierce the outlet so that medication may be injected through the valve. The outlet end does need to be strong enough to resist whatever level of back pressure may be expected from the valve's outlet 50.

The outlet housing portion 48 includes a ledge 24 to prevent the gland 12--in particular, the gland's attachment section 20--from extending too far towards the valve's

outlet 50. This ledge 24 does not stop the movement of the cannula 14 towards the outlet 50; thus, the cannula's outlet end 58 may continue to move toward the valve's outlet 50 and separate from the gland 12, thereby opening the second seal area 22, if it has not yet opened. The outlet housing portion 48 also includes ribs 26 for stopping the movement of the cannula 14 toward the valve's outlet 50, while permitting flow from the cannula 14 between the ribs 26 to the valve's outlet.

To facilitate the centering of the nozzle as it is being inserted into the valve, the interior surface of the gland's seal section 10 has a small hollow area 46 shaped to receive the inlet end 38 of the cannula 14. The inlet end of the cannula 14 is shaped to cause the opening of the seal section's aperture 42 when the seal section 10 is squeezed between the cannula 14 and the nozzle with sufficient force. When the nozzle 60 is first pressed against the gland's seal section 10, the seal section 10 is pressed toward the cannula 14, causing the hollow area 46 of the seal section 10 down over the inlet end 38 of the cannula 14, as shown in FIG. 2. This motion causes the top of the inlet section 10 to fall below the exterior inlet face 52 of the housing, thereby facilitating the centering of the nozzle 60.

As can be seen in FIG. 3, as the nozzle 60 is continued to be pushed into the valve, the vent 16 allows the gland 12 to separate from the expanding zone 44 of the inlet housing portion 34, thereby easing the movement of the gland 12 through the inlet housing portion 34. At some point as the cannula 14 is forced down into the valve, the cannula's outlet end 58 separates from the gland 12, thereby opening up the second seal area 22. This opening of the second seal area occurs as the compressible, tubular section 18 of the gland 12 is compressed by the nozzle 60 pushing the cannula 14 downward. As shown in FIG. 4, further insertion of the nozzle 60 into the valve results in the attachment section 20 of the gland stretching until it reaches the ledge 24, which prevents further stretching of the attachment section 20.

FIG. 5 shows the nozzle 60 and the cannula's inlet end 38 having forced open the aperture 42 in the gland's seal section 10. Because the seal section 10 is in the widened zone 44 of the housing's passageway, the seal section 10 has room to spread. After the seal section's aperture 42 is opened, the luer-taper nozzle 60 should become fully seated in the tapered zone 40 of the inlet. If the nozzle 60 forces the cannula 14 too far down,

movement of the cannula 14 will be stopped by ribs 26. The ribs 26 permit flow between the cannula's outlet end and the outlet housing portion 48, even when the cannula 14 is pushed down all the way. After the nozzle is removed from the valve, the stretched attachment section 20 of the gland and the compressed tubular section of the gland 18  
5 tend to return to their original shapes, causing the seal section 10 to be forced back into the tapered zone 40. Since, as noted above, the tapered zone 40 has a smaller diameter than the outer diameter of the seal section 10, the aperture 42 is squeezed closed, thereby returning the valve to its closed mode.

FIG. 7 shows an alternative embodiment for the gland 20 shown in FIG. 1. The  
10 FIG. 7 gland is molded in two shots, so that the attachment section 20 is made of a type of silicone or other material that has good stretching properties, while the rest of the gland is made of material that has good compression properties. FIG. 8 shows a gland 12 made according to a method that simplifies molding considerations. The gland 12 is molded in the shape shown in FIG. 8, which shape is simpler to mold than the gland shape shown in  
15 FIGS. 1 and 7; the attachment section 20 is folded upward prior to it being attached to the gland retention area (item 32 in FIG. 1) between the inlet housing portion 34 and the outlet housing portion 48 during ultrasonic welding.

FIG. 9 shows a preferred embodiment of the gland that may be used in the FIG. 1 valve. The tubular section 18a of the gland, instead of being accordion-shaped like the  
20 gland shown in FIG. 1, has a simple annular design. When the valve is assembled, this tubular section 18a is preferably preloaded in a compressed state when the valve is closed in order to maintain sufficient sealing force at the seal area against the outlet end of the cannula 14. As noted above, such preloading may be accomplished by making the tubular section 18a between the seal area 22 and the section 54 of the gland that corresponds to  
25 the ledge on the cannula longer than the corresponding section on the cannula 14.

In order to reduce friction between the housing and the attachment section 20b of the gland, the contact between the attachment section and the housing may be limited to a wiper member 74. The wiper member 74 helps ensure that liquid does not make its way up into the section between the attachment section 20b and the housing, while reducing  
30 the contact area between the attachment section 20b and the housing. In such an

embodiment, the attachment section 20b may include a vent port therethrough in order to prevent a vacuum forming between the attachment section and the housing.

FIG. 10 shows an alternative valve design, wherein the cannula's outlet end 58a includes a leaf spring 62 to urge the cannula 14a up into its closed position. Like the valve shown in FIG. 1, a widened area of the cannula's outlet end 58a in the FIG. 10 valve forms a second seal area 22a, and a diverter channel 28a redirects flow from the cannula's main passageway 36a. Unlike the FIG. 1 valve, the attachment section 20a of the gland 12a in the FIG. 10 valve is not stretched, but rather it folds upon itself. FIG. 11 shows a variation of the FIG. 10 valve. The FIG. 11 valve is shown in the open position. As shown in FIG. 11, the gland's attachment section 20a is folded as the valve is opened. In the FIG. 11 embodiment, the cannula's outlet end 22b is shaped so as to prevent further movement of the cannula towards the valve's outlet 50 while still permitting flow to the outlet.

FIG. 12 shows a variation of the FIG. 11 valve with a different variation of the leaf spring 62a. In the FIG. 12 valve, a portion of the tapered zone 40b of the valve's inlet has ribs 64, while another portion 65 of the tapered zone 40b has a frusto-conical shape that is able to maintain contact around the entire circumference of the nozzle. The frusto-conical portion 65 maintains a seal between the nozzle and the valve housing when the nozzle is inserted all the way into the valve. The ribs 64 reduce the friction between the gland's seal section 10b and the tapered zone, so as to make it easier for the seal section 10b to return to its closed position when the nozzle is removed from the valve. The ribs 64 also provide a stronger hold on an inserted nozzle than if the entire tapered zone 40b had frusto-conical shape. The ribs provide a further benefit if a vent is not provided in the inlet housing portion: the ribs reduce the length that the gland has to travel without the space between the gland and the inlet housing portion being vented to atmosphere.

FIG. 13 shows the valve of FIG. 1 adapted to include ribs 64a in the tapered zone 40 of the inlet section. These ribs 64a may also be seen in FIG. 13A, which shows a cross section through the inlet section 40 of the FIG. 13 valve. FIG. 13 also shows the tapered sections of the housing passageway that enable the cannula to properly return from the fully open position to the closed position. Specifically, the passageway may be considered to include three tapered sections (among other sections). The first section

begins at the aperture compression zone 40 and converges toward a point "X." In preferred embodiments, the aperture compression zone 40 has an inner diameter of about 0.169 inches and converges toward point X, which has an inner diameter of about 0.162 inches. The second section begins at point X and diverges toward a point "Y" which, in preferred embodiments, may have an inner diameter of about 0.167 inches. The third section begins at point Y and diverges to a point "Z" which, in preferred embodiments, may have an inner diameter of about 0.200 inches.

FIGS. 14A-14C show how the seal section 10 of the gland may respond to the insertion of a nozzle 60 into the valve. When the valve is in the closed position, as shown in FIG. 14A, the aperture 42 is closed with both the bottom, point A, and the top, point B, of the aperture being pressed together by the tapered zone of the housing 40. (The exterior of the housing's inlet section preferably includes threads 82 to accept luer-lock threads surrounding a nozzle.) The nozzle 60 pushes the gland's seal section away from the exterior inlet face 52 and the tapered section 40 of the inlet. When the seal section reaches the widened portion 44 of the inlet section, the aperture 42 opens, with the point B of the aperture spreading more than point A, as shown in FIG. 14B. The shaping of the cannula's inlet end allows the aperture 42 to be opened quickly and closed quickly. As the nozzle 60 is inserted further into the valve, as shown in FIG. 14C, the seal section 10 of the gland is prevented from being forced too far down the cannula by step 80 on the cannula. Preferably, a portion of the gland remains between the cannula's inlet end 38 and the nozzle 60. The tip of the cannula's inlet end is preferably rounded (bullet-nosed) to minimize cutting of the gland material between the cannula and the nozzle and to promote the centering of the cannula's inlet end 38 with respect to the nozzle.

FIG. 15 shows an alternative embodiment of the invention. This embodiment is similar to the FIG. 1 embodiment, as the FIG. 15 embodiment includes a movable center cannula 14b, located inside a gland 12b, which in turn is located within the passageway formed by the inlet housing portion 34 and the outlet housing portion 48. When the valve is in the closed position, the gland's seal section 10b is spaced away from the top end 80b of the cannula 14b. When the valve is being opened, as shown in FIGS. 16A-16D, the gland's seal section 10b moves towards the cannula's top surface 80b. This movement is

limited by a step 91 on the inner surface of the gland 14b, which prevents the seal section 10b from moving past cannula's top surface 80b.

As shown in FIG. 16A, the seal section 10b is substantially aligned with the exterior inlet face 52 and extends slightly beyond the exterior inlet face, so as to provide a swabbable surface. The outer diameter of the seal section 10b is a little greater than the inner diameter of the inlet's tapered section 40, so that the resulting pressure keeps the aperture 42 closed when the valve is in the closed position. Because the valve includes a high-pressure seal area 22, the seal section's aperture 42 does not have to resist high back pressure.

10 As the nozzle 60 is inserted into the valve's inlet, as shown in FIG. 16B, the gland's seal section 10b is urged towards the cannula 14b, which in turn is urged towards the valve's outlet 50. As the seal section 10 moves from the inlet's tapered section 40 to the inlet's expanding section 44, which has a greater inner diameter than the seal section's outer diameter, the aperture 42 in the gland's seal section 10 begins to open, as can be  
15 seen in FIG. 16E. Also, the cannula's outlet end 58 begins to separate from the gland 12b, opening the high-pressure seal and providing fluid communication between the cannula's transverse passage 28 and the valve's outlet 50.

As the nozzle 60 is further inserted into the valve's inlet, as shown in FIG. 16C, the seal section 10b moves further in the inlet's expanding section 44, so that the  
20 increasing inner diameter of the inlet permits the seal section's aperture 42 to open further, as shown in FIG. 16F. The step 91 on the inner surface of the gland 14b is pressed against the top surface 80b of the cannula 14b, so that further movement of the seal section 10b towards the cannula 14b causes deformation of the sidewalls 93 of the gland 12b adjacent the seal section 10b.

25 The cannula's top surface 80b, along with the gland's inner lip 91, prevents the seal section 10b from being pushed beyond the cannula's top surface, as shown in FIG. 16D. FIG. 16D shows the nozzle 60 fully inserted into the valve. The seal section's aperture 42 is fully opened, as shown in FIG. 16G. By keeping the seal section 10b from being pushed beyond the cannula's top surface 80b, the seal section 10b is able to spring back to  
30 its original position quickly, when the nozzle is removed from the valve.

FIG. 17 shows another alternative embodiment of the invention. This embodiment is similar to the embodiment shown in FIG. 15 since it includes a movable center cannula 14c, located inside a gland 12c, which in turn is located within the passageway formed by the inlet housing portion 34 and the outlet housing portion 48. When the valve is in the closed position, the gland's seal section 10c is spaced away from the top end 80c of the cannula 14c. When the valve is being opened, as shown in FIGS. 18A-18D, the gland's seal section 10c moves towards the cannula's top surface 80c. This movement is limited by a step 91c on the inner surface of the gland 12c, which prevents the seal section 10c from moving past cannula's top surface 80c.

10 Improving upon the embodiment shown in FIG. 15, the gland 12c of FIG. 17 includes a ridge 97 that normally is seated on a ledge 98 formed by the interior walls of the outlet housing portion 48. In addition, the tapered outlet end 58c of the cannula 14c includes ribs 99 for limiting longitudinal motion of the cannula 14c toward the outlet end 50 of the valve. Accordingly, there is no need for ribs to protrude from the interior walls  
15 of the outlet housing portion 48.

FIGS. 18A-18D show of the valve of FIG. 17 as it is urged by a luer-taper nozzle 60 from a substantially fully closed position to a substantially fully open position. Specifically, in FIG. 18A, the seal section 10c is substantially aligned with the exterior inlet face 52 and extends slightly beyond the exterior inlet face to provide a swabbable  
20 surface. The outer diameter of the seal section 10c is a little greater than the inner diameter of the inlet's tapered section 40, so that the resulting pressure keeps the aperture 42 closed when the valve is in the closed position. Because the valve includes the high-pressure seal area 22, the seal aperture 42 does not have to resist high back pressure.

As the nozzle 60 is inserted into the valve's inlet, as shown in FIG. 18B, the  
25 gland's seal section 10c is urged towards the cannula 14c, which in turn is urged towards the valve's outlet 50. As the seal section 10c moves from the inlet's tapered section 40 to the inlet's expanding section 44, which has a greater inner diameter than the seal section's outer diameter, the aperture 42 in the gland's seal section 10c begins to open. Also, the cannula's outlet end 58c begins to separate from the gland 12c, opening the high-pressure  
30 seal and providing fluid communication between the cannula's transverse passage 28 and the valve's outlet 50.

As the nozzle 60 is further inserted into the valve's inlet, as shown in Fig. 18C, the seal section 10c moves further in the inlet's expanding section 44, so that the increasing inner diameter of the inlet permits the seal section's aperture 42 to open further. The step 91c on the inner surface of the gland 12c is pressed against the top surface 80c of the cannula 14c, so that further movement of the seal section 10c towards the cannula 14c causes deformation of the sidewalls 93 of the gland 12c adjacent the seal section 10c.

The cannula's top surface 80c, along with the gland's step 91c, prevents the seal section 10c from being pushed beyond the cannula's top surface 80c, as shown in Fig. 18D. Fig. 18D shows the nozzle 60 fully inserted into the valve with the seal section's aperture 42 fully opened. By keeping the seal section 10c from being pushed beyond the cannula's top surface 80c, the seal section 10c is able to spring back to its original position quickly, when the nozzle is removed from the valve. Moreover, the ribs 99 on the outlet end 58c of the cannula 14c limit further longitudinal movement of the cannula 14c toward the outlet 50. It should be noted that the ridge 97 remains seated on the ledge 98 throughout the entire process shown in Figs. 18A-18D.

Although the invention has been described with reference to several preferred embodiments, it will be understood by one of ordinary skill in the art that various modifications can be made without departing from the spirit and scope of the invention, as set forth in the claims hereinbelow.

For the purpose of this specification the words "comprising", "comprise" or "comprises" are understood to mean the inclusion of a feature but not exclusion of any other feature.



THE CLAIMS DEFINING THE INVENTION ARE AS FOLLOWS:

1. A normally closed valve that may be opened upon insertion of a luer-tapered nozzle, the valve comprising:

5 a housing defining a passageway having an inlet section and an outlet section, the housing being substantially rigid and having an exterior inlet face to which the inlet section opens;

10 a substantially rigid cannula disposed within the passageway and extending into the inlet section, the cannula being movable within the housing between first and second positions corresponding to closed and open modes of the valve, the cannula having an inlet end and an outlet end;

15 a substantially flexible, resilient gland member having

a seal section disposed over the inlet end of the cannula, the seal section having a normally closed aperture therethrough,

20 a tubular section connected to the seal section and disposed around the cannula between cannula and the housing, and

an attachment section connected to the tubular section and attached to the housing;

25 wherein, when the valve is in its closed mode, the seal section is substantially aligned with the exterior inlet face of the housing so as to provide a swabbable surface,

30 the gland and cannula cooperating when in the closed mode to seal the valve.

2. A valve according to claim 1, wherein the inlet end of the cannular and the gland are shaped to permit a length of travel of the seal section with respect to the cannular, and wherein the valve includes means for  
35 restricting movement of the seal section through the inlet section beyond the length of travel.



3. A valve according to claim 2, wherein the inlet end of the cannula is spaced away from the seal section when the valve is in its closed mode.

5 4. A valve according to claim 3, wherein the inlet section of the housing's passageway has a tapered zone adjacent the exterior inlet face and being shaped to receive the nozzle, and

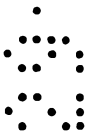
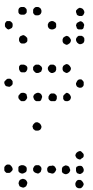
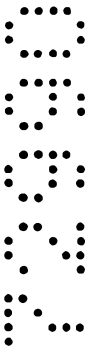

an expanding zone adjacent to the tapered zone and having a greater inner diameter than the tapered zone's inner diameter, wherein the gland member's seal section has an outer diameter that is larger than the tapered zone's inner diameter and smaller than the expanding zone's inner diameter, and wherein, the seal section's aperture opens after the nozzle presses the seal section past the tapered zone into the expanding zone of the inlet section.

- 5
- 10
- 15
- 20
- 25
- 30
5. A valve according to claim 4, wherein the inlet section's tapered zone has a frusto-conical belt, adjacent the exterior inlet face, that maintains contact around the nozzle's entire circumference when the nozzle is fully inserted into the valve, and a ribbed belt, between the frusto-conical belt and the expanding zone, that maintains contact with less than the nozzle's entire circumference.
  6. A valve according to claim 4, wherein the outlet end of the cannula is shaped so as to provide a back-pressure seal with the gland member.
  7. A valve according to claim 6, wherein the tubular section of the gland member is under compression when the valve is fully closed.
  8. A valve according to claim 7, wherein the exterior of the inlet section of the housing has threads to accept luer-lock threads surrounding a nozzle.
  9. A valve according to claim 8, wherein the attachment section of the gland member is stretched as the valve is urged by the nozzle from the valve's closed mode to the valve's opened mode.
  10. A valve according to claim 9, wherein the tubular section of the gland member is further compressed as the valve is urged by the nozzle from the valve's closed mode to the valve's opened mode.



11. A valve according to claim 10, wherein the housing includes gland-stopping structure for stopping movement of the gland towards the outlet section of the valve independently of movement of the cannula.

5 12. A valve according to claim 11, further including a cannula-stopping structure for stopping movement of the cannula towards the outlet section of the valve while permitting flow to the outlet section of the valve.

10 13. A valve according to claim 11, wherein the housing includes a rigid annular member disposed between the gland member's attachment section and the gland member's tubular section.

15 14. A valve according to claim 13, wherein the gland member's attachment section includes a flexible wiper member, located at the attachment section's outlet end, for maintaining contact between the attachment section and the housing at the attachment section outlet end.

20 15. A valve according to claim 14, wherein the gland member's attachment section includes a vent port.

16. A valve according to claim 15, wherein the housing includes a vent in the inlet section.

25 17. A valve according to claim 8, wherein the outlet end of the cannula is shaped to provide a flexible member that urges the cannula into the first position.

18. A valve according to claim 2, wherein the inlet end of the cannula is shaped to urge the seal section open.

30 19. The valve according to claim 1 wherein the outlet end of the cannula has a tapering outer diameter and ribs.



20. The valve according to claim 1, wherein the passageway is defined in part by an inner wall, the inner wall being free of ribs.

5 21. The valve according to claim 1, wherein the gland includes a ridge and the passageway is defined in part of a ledge, wherein the ridge is seated on the ledge.

10 22. The valve according to claim 1, wherein the passageway is defined in part by a ledge, the gland being seated on the ledge during both the closed mode and the open mode.

15 23. A normally closed valve that may be opened upon insertion of a luer-tapered nozzle, the valve comprising:  
a housing defining a passageway having an inlet section and an outlet section, the housing being substantially rigid and having an exterior inlet face to which the inlet section opens;

20 a substantially rigid cannula disposed within the passageway and extending into the inlet section, the cannula being movable within the housing between first and second positions corresponding to closed and open modes of the valve, the cannula having an inlet end and an outlet end;

25 a substantially flexible, resilient gland member having

30 a seal section disposed over the inlet end of the cannula, the seal section having a normally closed aperture therethrough, and

a tubular section connected to the seal section and disposed around the cannula between cannula and the housing,

35 wherein the outlet end of the cannula is shaped so as to provide a back-pressure seal with the gland member, and

wherein, when the valve is in its closed mode,



the seal section is substantially aligned with the exterior inlet face of the housing so as to provide a swabbable surface,

the gland and cannula cooperating when in the  
5 closed mode to seal the valve.

5  
6  
7  
8  
9

10  
11  
12  
13

14  
15  
16



24. A valve according to claim 23, wherein the tubular section of the gland member is under compression when the valve is fully closed.

25. A valve according to claim 24, wherein the tubular section of the gland member is further compressed as the valve is urged by the nozzle from the valve's closed mode to the valve's opened mode.

26. A valve according to claim 25, wherein the housing includes gland-stopping structure for stopping movement of the gland towards the outlet section of the valve independently of movement of the cannula.

27. A valve according to claim 26, further including a cannula-stopping structure for stopping movement of the cannula towards the outlet section of the valve while permitting flow to the outlet section of the valve.

28. A valve according to claim 27, wherein the inlet section of the housing's passageway has

a tapered zone adjacent the exterior inlet face and being shaped to receive the nozzle, and

an expanding zone adjacent to the tapered zone and having a greater inner diameter than the tapered zone's inner diameter,

wherein the gland member's seal section has an outer diameter that is larger than the tapered zone's inner diameter and smaller than the expanding zone's inner diameter, and

wherein, the seal section's aperture opens after the nozzle presses the seal section past the tapered zone into the expanding zone of the inlet section.

29. A valve according to claim 28, wherein the inlet section's tapered zone has a frusto-conical belt, adjacent the exterior inlet face, that maintains contact around the nozzle's entire circumference when the nozzle is fully inserted into the valve, and

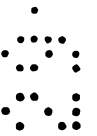
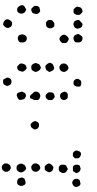
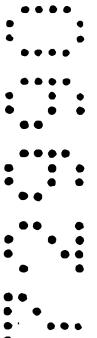

a ribbed belt, between the frusto-conical belt and the expanding zone, that maintains contact with less than the nozzle's entire circumference.

5 30. A valve according to claim 29, wherein the exterior of the inlet section of the housing has threads to accept luer-lock threads surrounding a nozzle.

10 31. A valve according to claim 23, wherein the outlet end of the cannula includes a rib.

15 32. The valve according to claim 23, wherein the gland includes a ridge and the passageway is defined in part of a ledge, wherein the ridge is seated on the ledge.

20 33. The valve according to claim 23, wherein the passageway is defined in part by a ledge, the gland being seated on the ledge during both the closed mode and the open mode.

25 34. A normally closed valve that may be opened upon insertion of a luer-tapered nozzle, the valve comprising:  
a housing defining a passageway having an inlet section and an outlet section, the housing being substantially rigid and having an exterior inlet face to which the inlet section opens;

30 a substantially rigid cannula disposed within the passageway and extending into the inlet section, the cannular being movable within the housing between first and second positions corresponding to closed and open modes of the valve, the cannula having an inlet end and an outlet end;

35 a substantially flexible, resilient gland member having

a seal section disposed over the inlet end of the cannula, the seal section having a normally closed aperture therethrough, and



a tubular section connected to the seal section and disposed around the cannula;

wherein the inlet section of the housing's passageway has a tapered zone adjacent the exterior inlet face and being shaped to receive the nozzle, and

an expanding zone adjacent to the tapered zone and having a greater inner diameter than the tapered zone's inner diameter;

wherein the gland member's seal section has an outer diameter that is larger than the tapered zone's inner diameter and smaller than the expanding zone's inner diameter, and

wherein the seal section's aperture opens after the nozzle presses the seal section past the tapered zone into the expanding zone of the inlet section,

wherein, when the valve is in its closed mode, the seal section is substantially aligned with the exterior inlet face of the housing so as to provide a swabbable surface,

the gland and cannular cooperating when in the closed mode to seal the valve.

35. A valve according to claim 34, wherein the inlet end of the cannula and the gland are shaped to permit a length of travel of the seal section with respect to the cannular.

36. A valve according to claim 35, wherein the inlet end of the cannular is shaped to urge the seal section open.

37. A valve according to claim 35, further including means for restricting movement of the seal section through the inlet section beyond the length of travel.

38. A valve according to claim 37, wherein the inlet end of the cannula is shaped to urge the seal section



open.

39. A valve according to claim 37, wherein the inlet  
end of the cannula is spaced away from the seal section  
5 when the valve is in its closed mode.

40. A valve according to claim 39, wherein the  
outlet end of the cannula is shaped so as to provide a  
back-pressure seal with the gland member.

10

41. A valve according to claim 40, wherein the  
cannula includes a ledge disposed between the step and the  
cannula's outlet end, and the tubular section has a  
subsection,

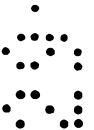
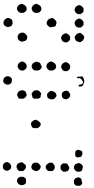
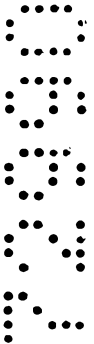

adjacent the seal section, shaped to correspond to the ledge, so as to prevent movement of the cannula's ledge past the tubular section's shaped subsection.

42. A valve according to claim 41, wherein the tubular section of the gland member is under compression when the valve is fully closed.

43. A valve according to claim 42, wherein the tubular section of the gland member is further compressed as the valve is urged by the nozzle from the valve's closed mode to the valve's opened mode.

10

44. A valve according to claim 43, wherein the housing includes gland-stopping structure for stopping movement of the gland towards the outlet section of the valve independently of movement of the cannula.

15

45. A valve according to claim 44, further including a cannula-stopping structure for stopping movement of the cannula towards the outlet section of the valve while permitting flow to the outlet section of the valve.

20

46. A valve according to claim 45, wherein the gland member further includes an attachment section connected to the tubular section and attached to the housing,

25

47. A valve according to claim 46, wherein the attachment section of the gland member is stretched as the valve is urged by the nozzle from the valve's closed mode to the valve's opened mode.

48. A valve according to claim 47, wherein the housing includes a rigid annular member disposed between the gland member's attachment section and the gland member's tubular section.

30

49. A valve according to claim 48, wherein the gland member's attachment section includes a flexible wiper member, located at the attachment section's outlet end, for



maintaining contact between the attachment section and the housing at the attachment section outlet end.

50. A valve according to claim 43, wherein the  
5 outlet end of the cannula is shaped to provide a flexible member that urges the cannula into the first position.

51. A valve according to claim 34, wherein the inlet  
10 section's tapered zone has a frusto-conical belt, adjacent the exterior inlet face, that maintains contact around the nozzle's entire circumference when the nozzle is fully inserted into the valve, and a ribbed belt, between the frusto-conical belt and the expanding zone, that maintains contact with less than the nozzle's entire circumference.

52. A valve according to claim 34, wherein the  
15 exterior of the inlet section of the housing has threads to accept luer-lock threads surrounding a nozzle.

53. The valve according to claim 34, wherein the  
20 outlet end of the cannula has a tapering outer diameter and ribs.

54. The valve according to claim 34, wherein the  
25 passageway is defined in part by an inner wall, the inner wall being free of ribs.

55. The valve according to claim 34, wherein the  
30 gland includes a ridge and the passageway is defined in part by a ledge, wherein the ridge is seated on the ledge.

56. The valve according to claim 34, wherein the  
35 passageway is defined in part by a ledge, the gland being seated on the ledge during both the closed mode and the open mode.

57. A normally closed valve that may be opened upon



insertion of a luer-tapered nozzle, the valve comprising:  
a housing defining a passageway having an inlet  
section and an outlet section, the housing being  
substantially rigid and having an exterior inlet face to  
5 which the inlet section opens;

a cannula movably mounted within the passageway  
and within the housing; and

10 a substantially flexible, resilient gland member  
located within the passageway, the gland member having a  
seal section being substantially aligned with the exterior  
inlet face when the valve is closed, and having a normally  
closed aperture therethrough;

15 wherein the inlet section of the housing's  
passageway has a tapered zone adjacent the exterior inlet  
face and being shaped to receive the nozzle, and

wherein the inlet section's tapered zone has  
a frusto-conical belt, adjacent the exterior  
inlet face, that maintains contact around the nozzle's  
entire circumference when the nozzle is fully inserted  
20 into the valve, and

a ribbed belt, adjacent the frusto-conical belt,  
that maintains contact with less than the nozzle's entire  
circumference,

25 the gland and cannula cooperating to normally  
closed the valve.

58. A valve according to claim 57, wherein the  
exterior of the inlet section of the housing has threads  
to accept luer-lock threads surrounding a nozzle.

59. The valve according to claim 57, wherein the  
outlet end of the cannula has a tapering outer diameter  
and ribs.

60. The valve according to claim 57, wherein the  
passageway is defined in part by an inner wall, the inner  
wall being free of ribs.



61. The valve according to claim 57, wherein the gland includes a ridge and the passageway is defined in part by a ledge, wherein the ridge is seated on the ledge.

5 62. The valve according to claim 57, wherein the passageway is defined in part by a ledge, the gland being seated on the ledge during both closed mode and the open mode.

10 63. A normally closed valve that may be opened upon insertion of a luer-tapered nozzle, the valve comprising:  
a housing defining a passageway having an inlet section and an outlet section, the housing being substantially rigid and having an exterior inlet face to  
15 which the inlet section opens;  
a substantially rigid cannula disposed within the passageway and extending into the inlet section, the cannula being movable within the housing between first and second positions corresponding to closed and open modes of  
20 the valve, the cannula having an inlet end and an outlet end, wherein the cannular's shape remains constant as the cannula is moved between first and second positions;  
a substantially flexible, resilient gland member having  
25 a seal section disposed over the inlet end of the cannular, the seal section having a normally closed aperture therethrough, and a tubular section connected to the seal section and disposed around the cannula between cannula and the housing;  
30 wherein, when the valve is in its closed mode, the seal section is substantially aligned with the exterior inlet face of the housing so as to provide a swabbable surface,  
the gland and cannula cooperating when in the  
35 closed mode to seal the valve.

64. The valve according to claim 63, wherein the



outlet end of the cannula has a tapering outer diameter and ribs.

5 65. The valve according to claim 63, wherein the passageway is defined in part by an inner wall, the inner wall being free of ribs.

10 66. The valve according to claim 63, wherein the gland includes a ridge and the passageway is defined in part by a ledge, wherein the ridge is seated on the ledge.

15 67. The valve according to claim 63, wherein the passageway is defined in part by a ledge, the gland being seated on the ledge during both the closed mode and the open mode.

20 68. A normally closed valve that may be opened upon insertion of a luer-tapered nozzle, the valve comprising:  
a housing defining a passageway having an inlet section and an outlet section, the housing being substantially rigid and having an exterior inlet face to which the inlet section opens;  
a substantially rigid cannula disposed within the passageway and extending into the inlet section, the  
25 cannula being movable within the housing between first and second positions corresponding to closed and open modes of the valve, the cannula having an inlet end and an outlet end;

30 a substantially flexible, resilient gland member having  
a seal section disposed over the inlet end of the cannular, the seal section having a normally closed aperture therethrough, and

35 a tubular section connected to the seal section and disposed around the cannula between cannula and the housing;

wherein, when the valve is in its closed mode,



the seal section is substantially aligned with the exterior inlet face of the housing so as to provide a swabbable surface, and

5 wherein the inlet end of the cannula and the gland are shaped to permit a length of travel of the seal section with respect to the cannula,

the gland member and cannula cooperating when in the closed mode to seal the valve.

10 69. A valve according to claim 68, wherein the valve includes means for restricting movement of the seal section through the inlet section beyond the length of travel.

15 70. A valve according to claim 69, wherein the inlet end of the cannula is spaced away from the seal section when the valve is in its closed mode.

20 71. A valve according to claim 70, wherein the inlet section of the housing's passageway has  
a tapered zone adjacent the exterior inlet face and being shaped to receive the nozzle, and  
an expanding zone adjacent to the tapered zone and having a greater inner diameter than the tapered  
25 zone's inner diameter,



wherein the gland member's seal section has an outer diameter that is larger than the tapered zone's inner diameter and smaller than the expanding zone's inner diameter, and

5 wherein, the seal section's aperture opens after the nozzle presses the seal section past the tapered zone into the expanding zone of the inlet section.

72. A valve according to claim 71, wherein the inlet section's tapered zone has a frusto-conical belt, adjacent the exterior inlet face, that maintains contact around the nozzle's entire circumference when the nozzle is fully inserted into the valve, and  
10 a ribbed belt, between the frusto-conical belt and the expanding zone, that maintains contact with less than the nozzle's entire circumference.

73. A valve according to claim 68, wherein the seal section remains entirely between the cannula and the exterior inlet face when the valve is open.

15 74. A valve according to claim 68, wherein the inlet end of the cannula is shaped to urge the seal section open.

75. The valve according to claim 68 wherein the outlet end of the cannula has a tapering outer diameter and ribs.  
20

76. The valve according to claim 68 wherein the passageway is defined in part by an inner wall, the inner wall being free of ribs.

77. The valve according to claim 68 wherein the gland includes a ridge and the  
25 passageway is defined in part by a ledge, wherein the ridge is seated on the ledge.

78. The valve according to claim 68 wherein the passageway is defined in part by a ledge, the gland being seated on the ledge during both the closed mode and the open mode.

30



79. A medical valve comprising:

a housing defining a passageway, the passageway having an inlet section and an outlet section;

5 a substantially rigid cannula movably mounted within the passageway and within the housing; and

a substantially flexible, resilient gland member secured to the housing and the cannula, the cannula being supported within the passageway by the gland member,

10 the valve having a closed mode and an open mode, the gland member and cannula cooperating when in the closed mode to seal the valve.

80. The valve as defined by claim 79, wherein the cannula is adapted to move between a first position  
15 corresponding to a closed mode and a second position corresponding to an open mode.

81. The valve as defined by claim 79, wherein the passageway includes:

20 an inlet;

a first section that converges from the inlet section;

a second section that diverges from the first section; and

25 a third section that diverges from the second section.

82. A medical valve having an open mode and a closed mode, the valve comprising:

30 a housing defining a passageway;

a rigid cannula movably mounted within the passageway and within the housing, the cannula having an inlet end and a sealing end, the sealing end formed to substantially seal the passageway when in the closed mode;  
35 and

a substantially flexible, resilient gland member having a seal disposed over the inlet end of the cannula,



the gland member and cannula cooperating when in the closed mode to seal the valve.

83. The valve as defined by claim 82, wherein the  
5 rigid cannula is movable within the passageway between the closed mode and the open mode, the sealing end of the cannula formed to enable liquid to pass through the passageway when in the open mode.

10 84. A medical valve for use with a luer-tapered nozzle, the valve comprising:

a housing defining a passageway having a tapered section with an inlet port, the passageway also having an expanding section;

15 a cannula movably mounted within the passageway and having an inlet, the cannula being movably mounted within the housing; and

a substantially flexible, resilient gland member having a seal section disposed over the inlet of the  
20 cannula, the seal section having a normally closed aperture therethrough;

the seal section being movable through the passageway between the tapered section of the passageway and expanding section of the passageway,

25 the aperture being substantially closed when the seal section is disposed in the inlet port,

the aperture being open when the seal section is disposed in the expanding section,

30 the valve having a closed mode and an open mode, the gland member and cannula cooperating when in the closed mode to seal the valve.

85. A normally closed valve substantially as herein described with reference to and as illustrated by the  
35 accompanying drawings.

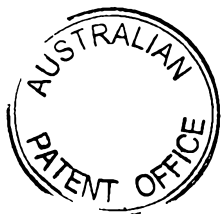

86. A medical valve substantially as herein described with reference to and as illustrated by the accompanying drawings.

5

Dated this 29<sup>th</sup> day of February 2002

NYPRO, INC.

By their Patent Attorneys

10 GRIFFITH HACK

Fellows Institute of Patent and

Trade Mark Attorneys of Australia

15

20



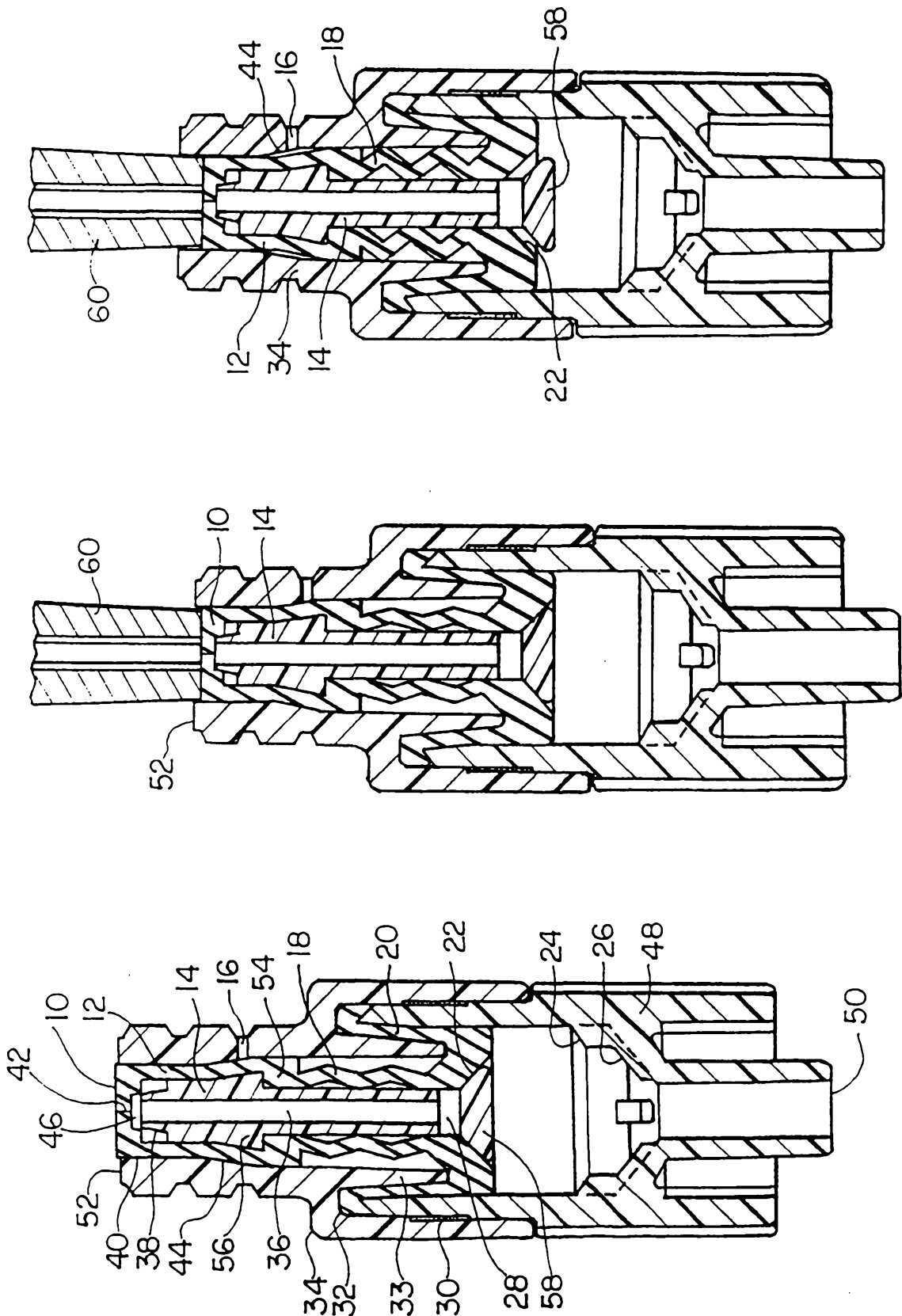

FIG. 3

FIG. 2

FIG. 1

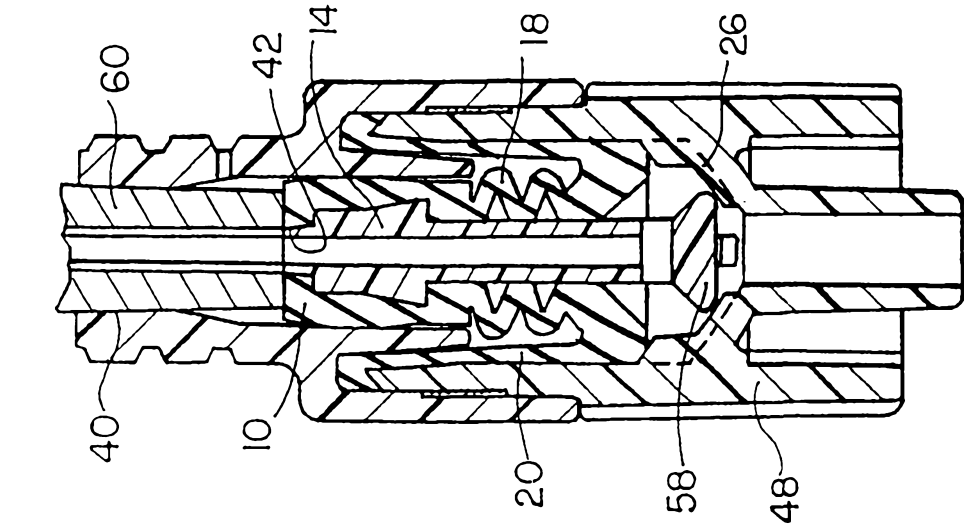

FIG. 6

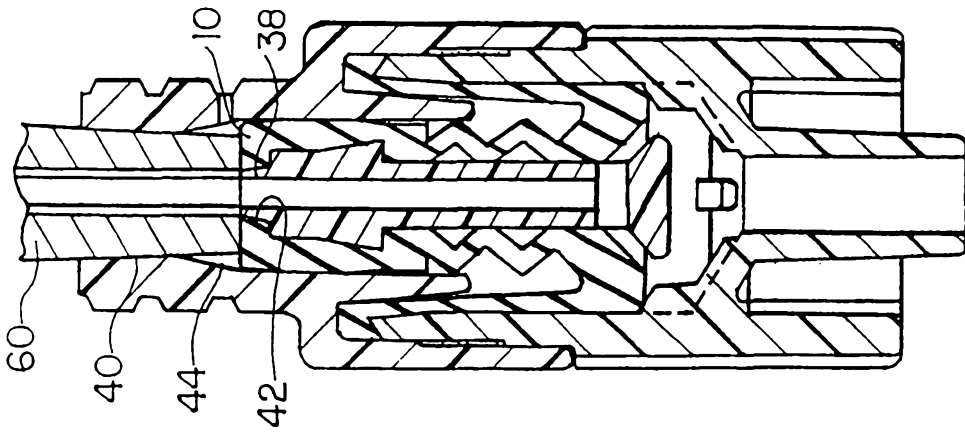

FIG. 5

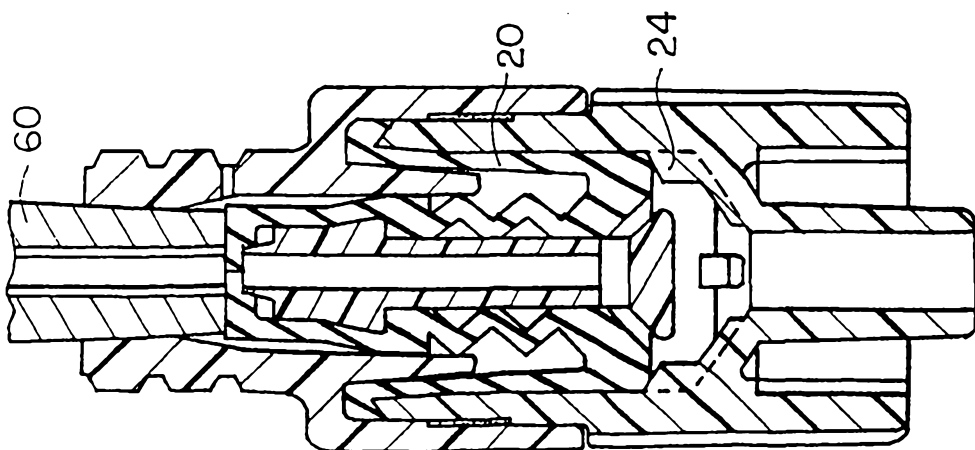

FIG. 4

3/12

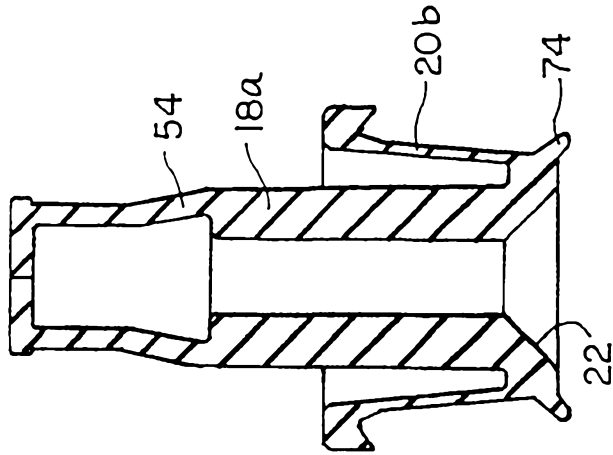

FIG. 9

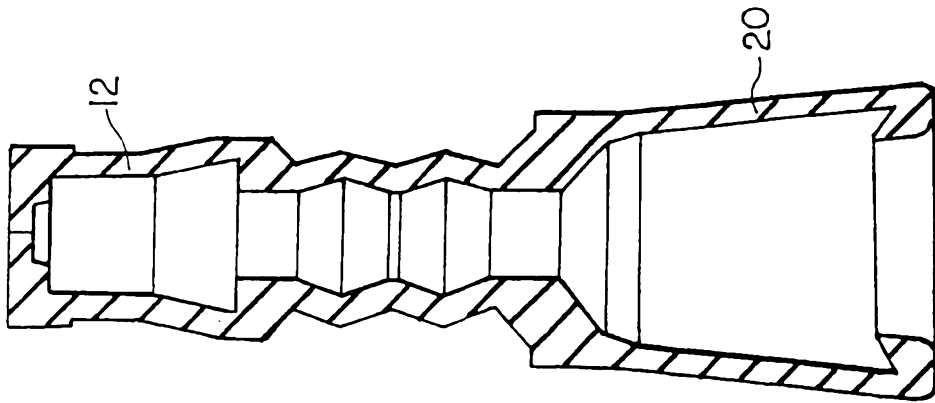

FIG. 8

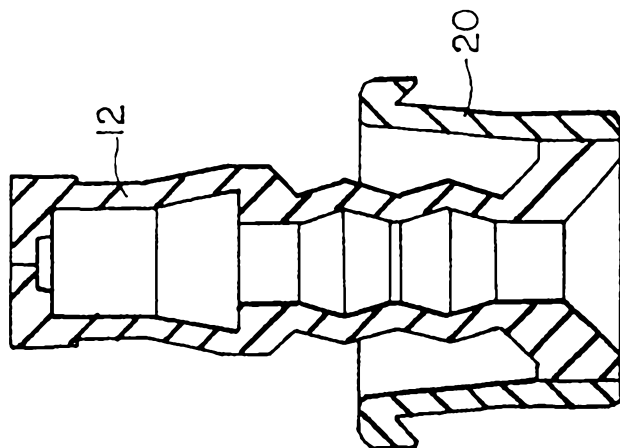

FIG. 7

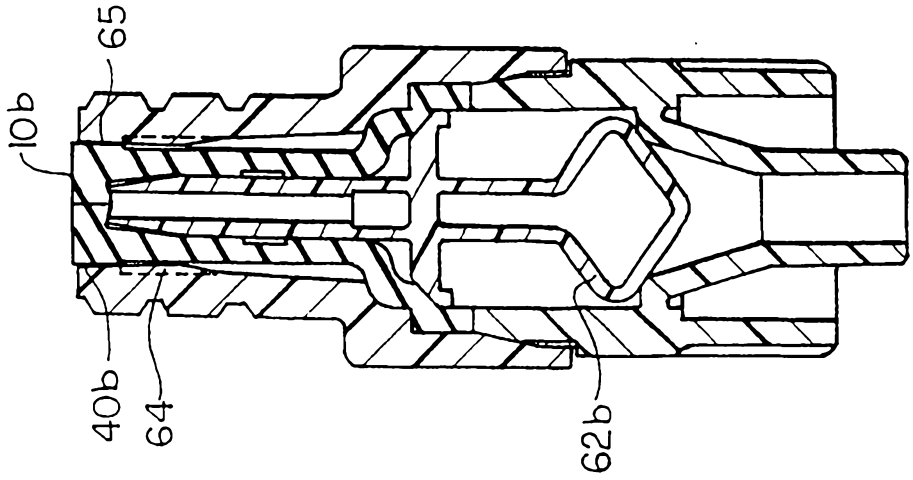

FIG. 12

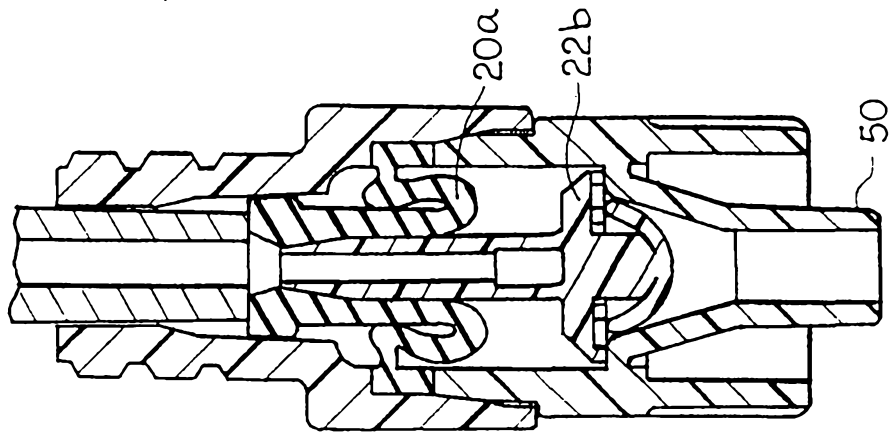

FIG. 11

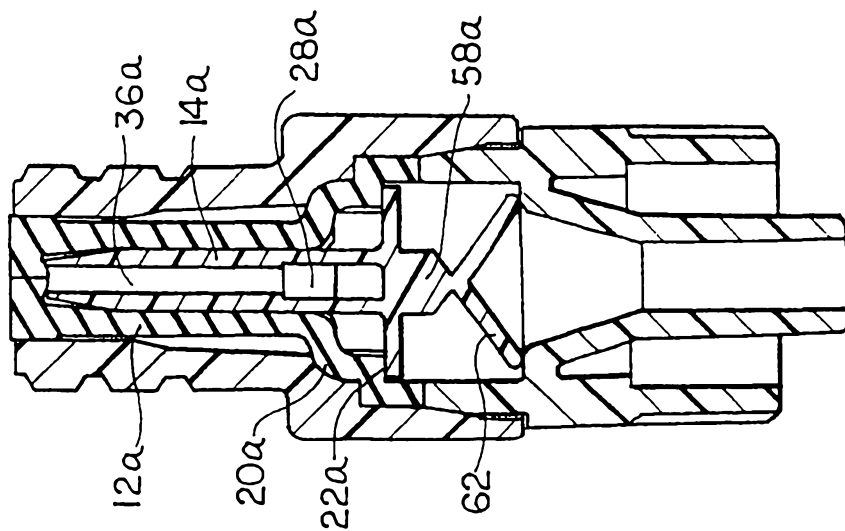

FIG. 10

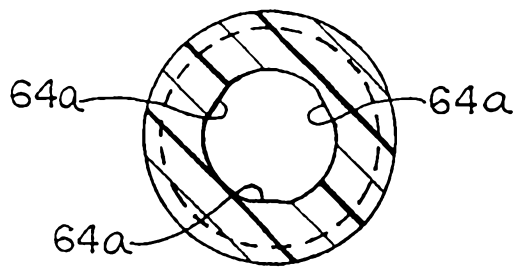

FIG. 13 A

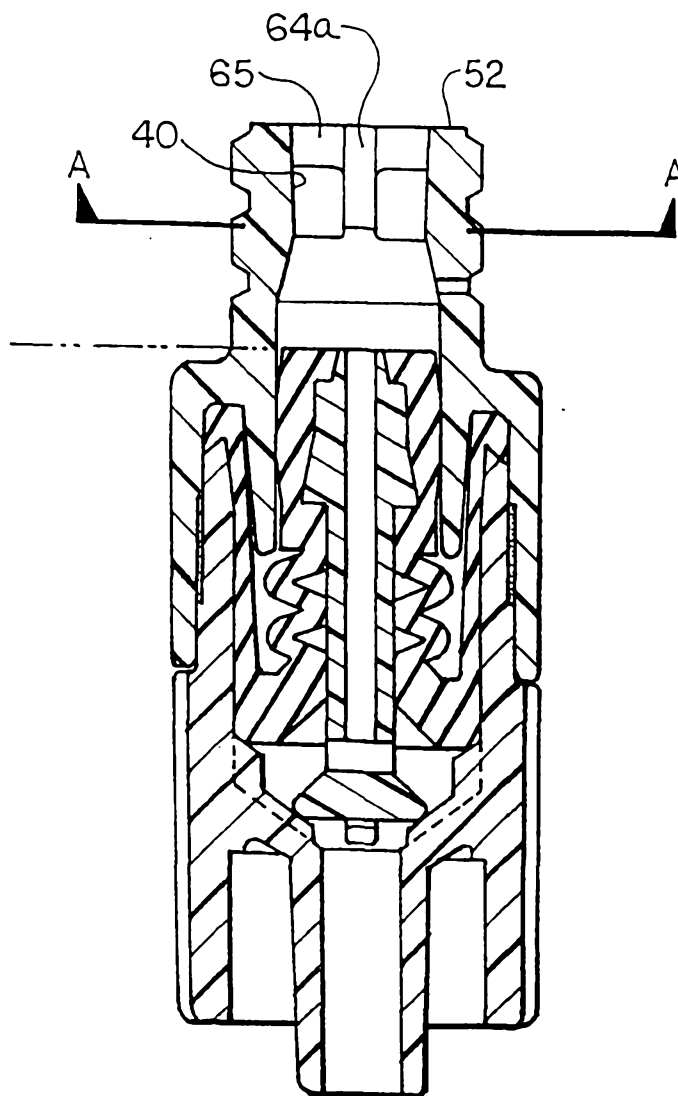
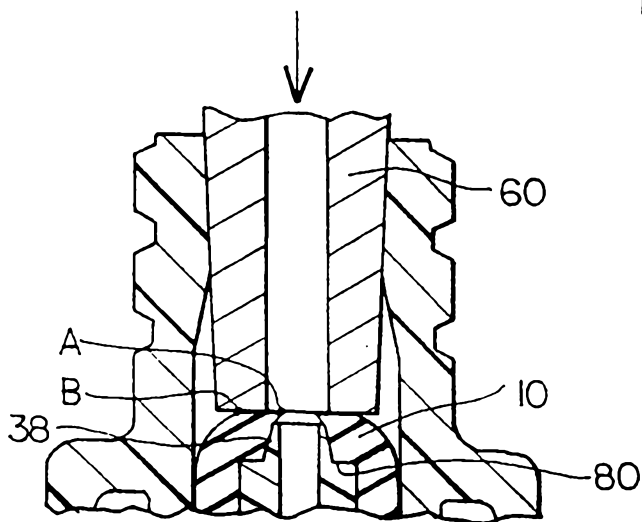
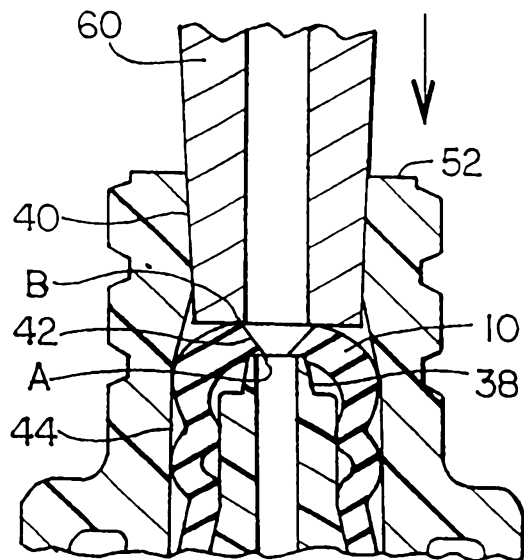
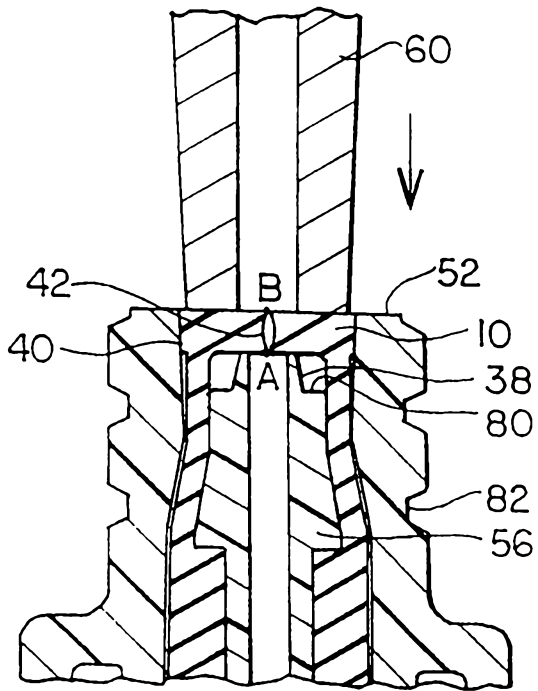

FIG. 13



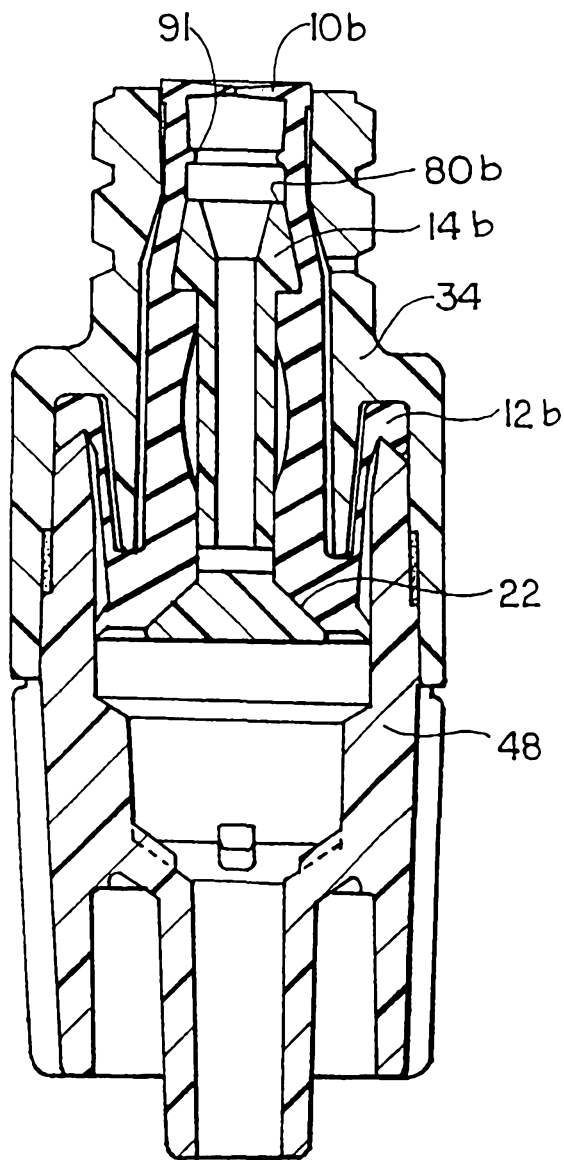

FIG. 15

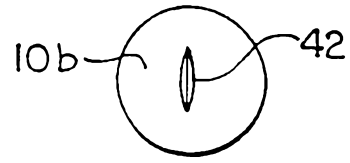

FIG. 16 E

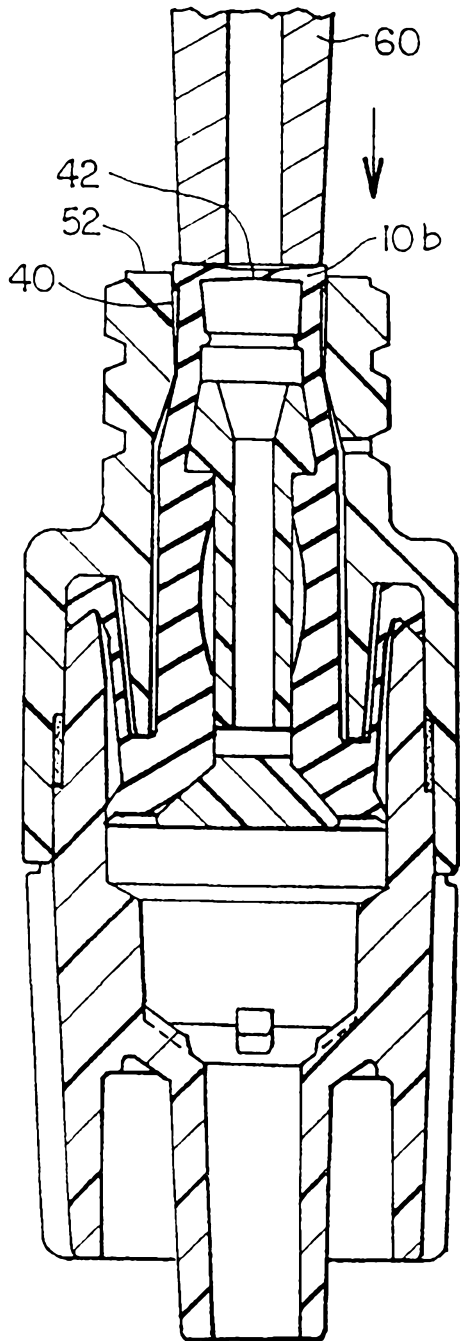

FIG. 16 A

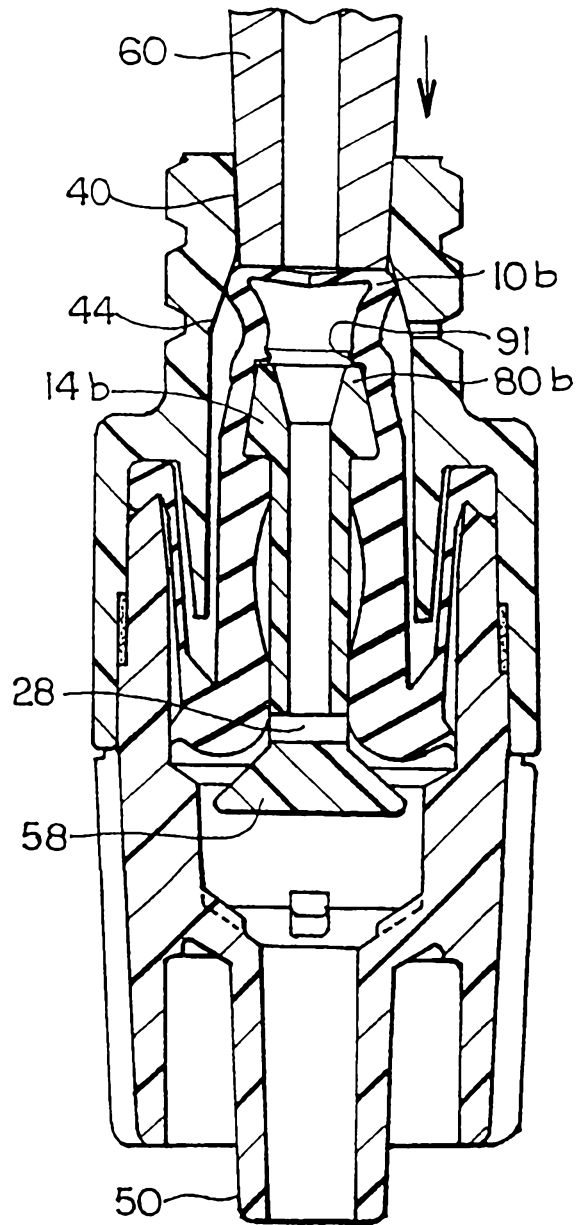

FIG. 16 B

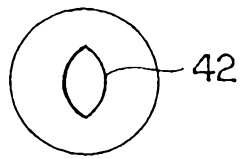

FIG. 16 F

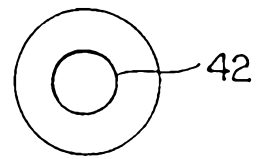

FIG. 16 G

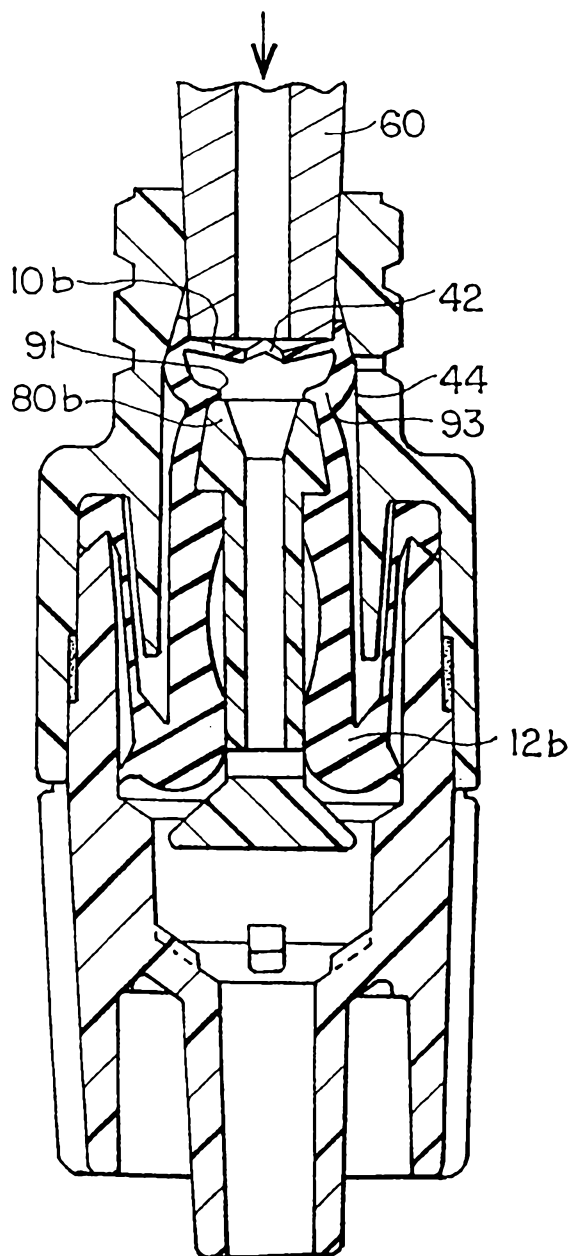

FIG. 16 C

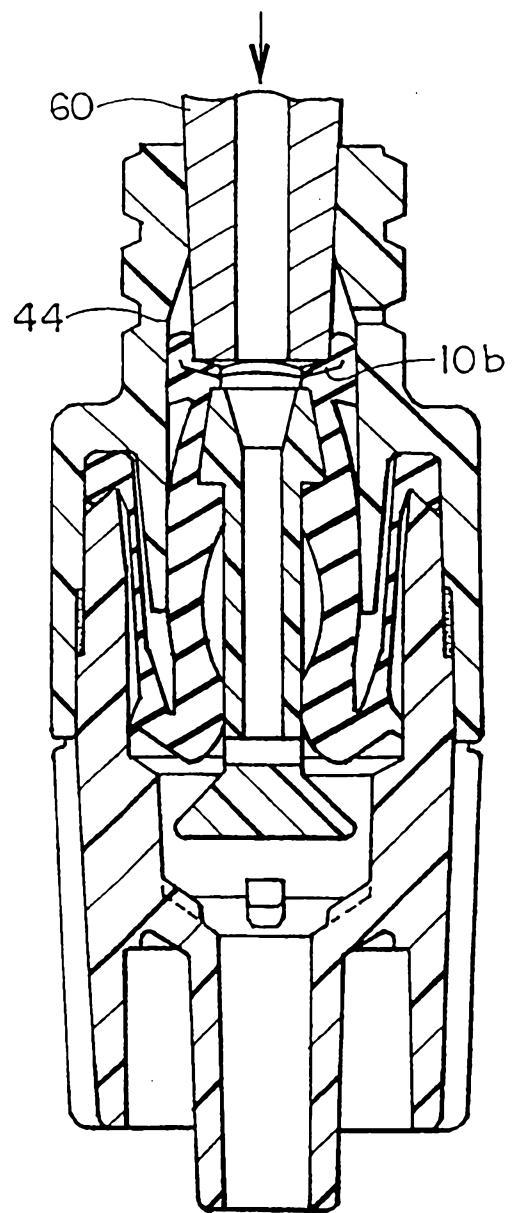

FIG. 16 D

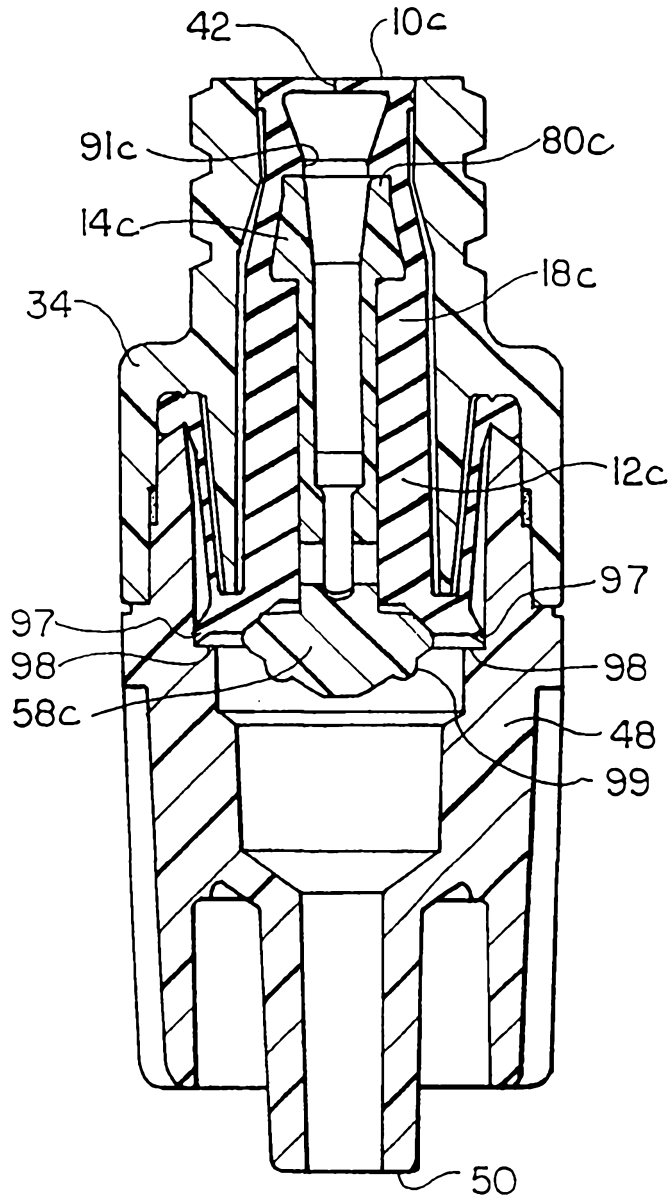

FIG. 17

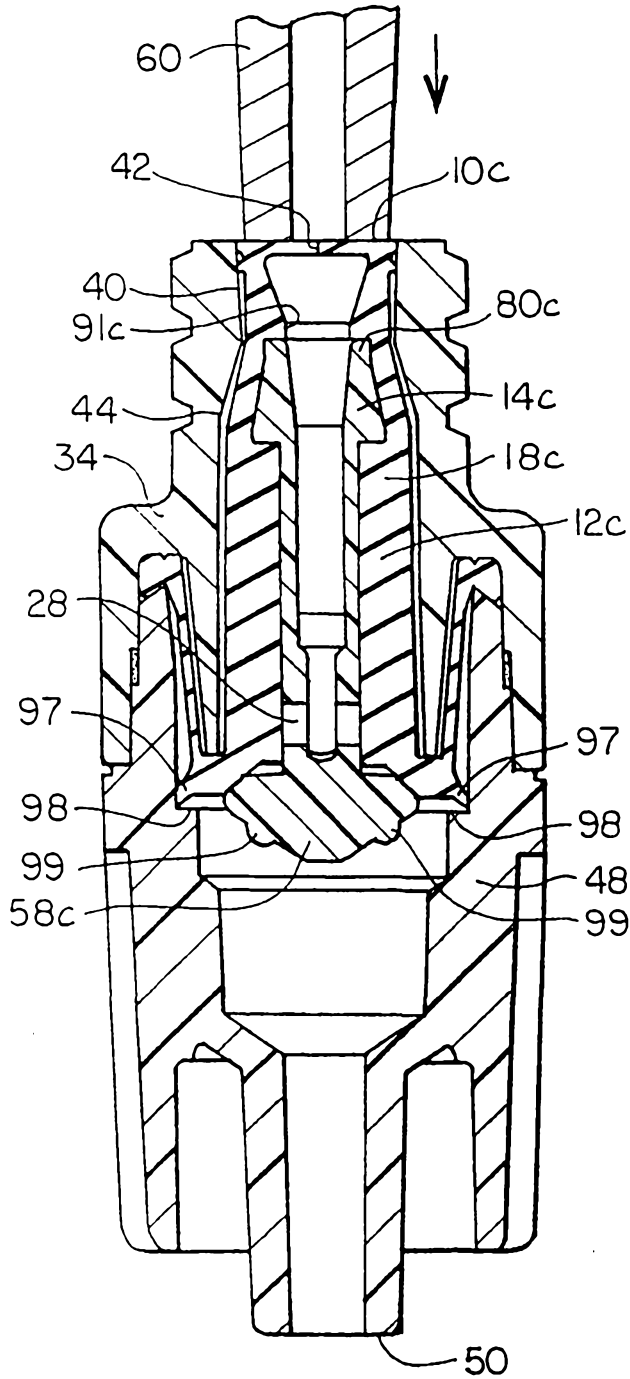

FIG. 18A

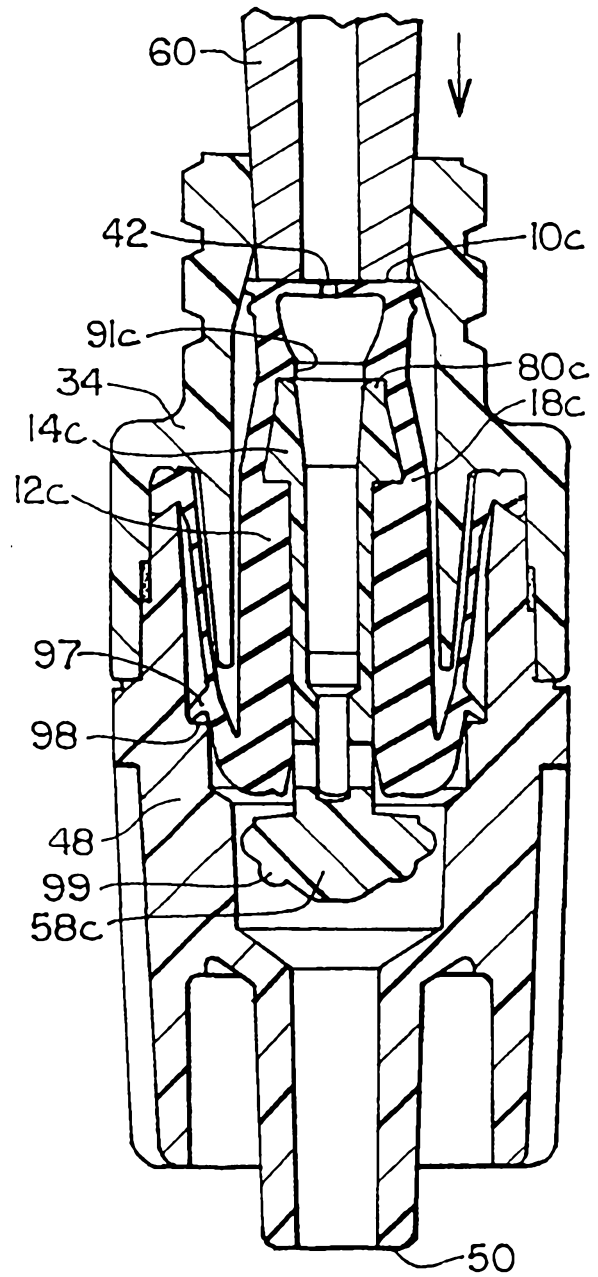

FIG. 18B

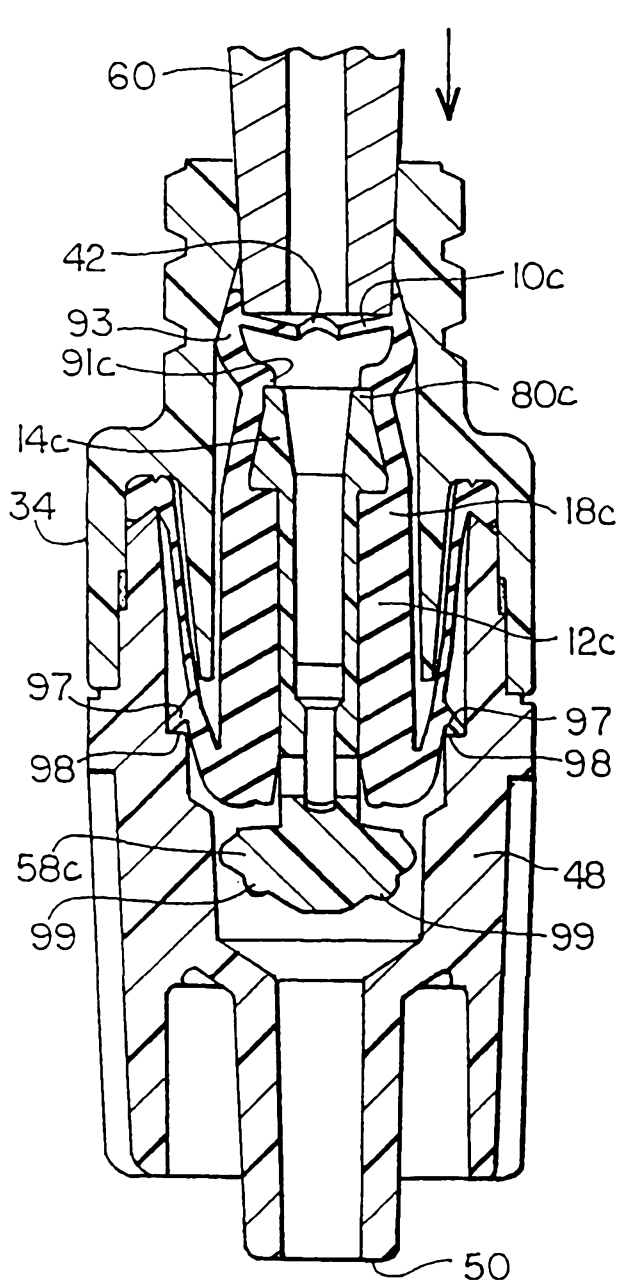

FIG. 18C

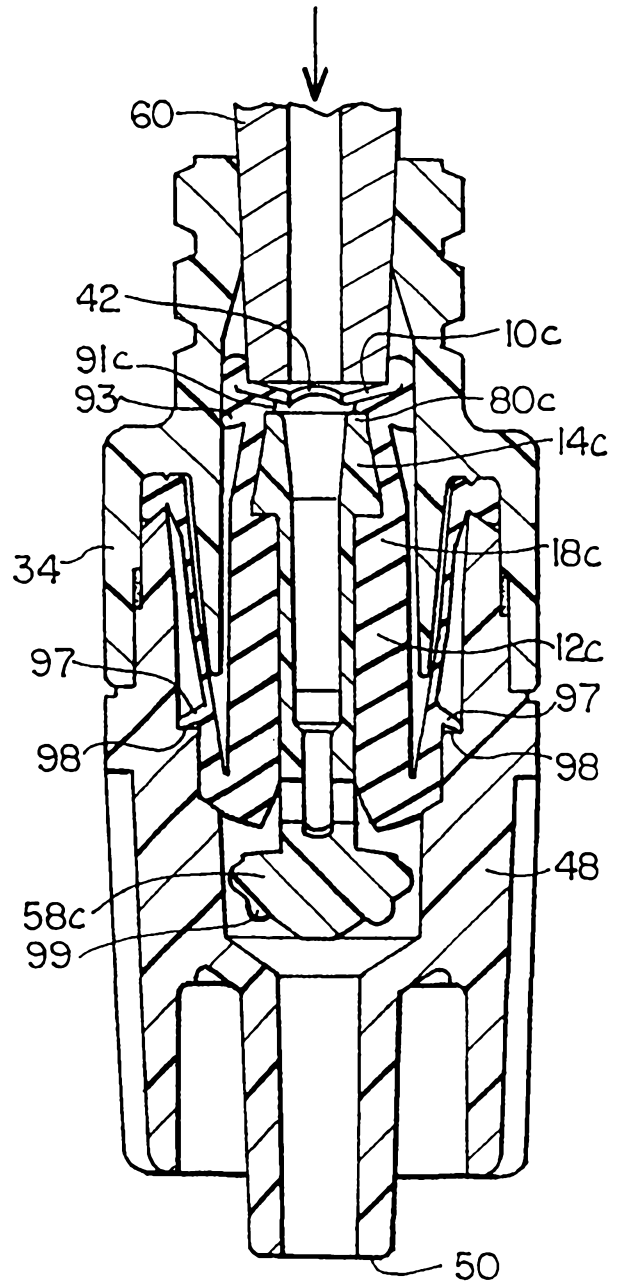

FIG. 18D