

A. C. CORSE.
Magazine Stove.

No. 107,597.

Patented Sept. 20, 1870.

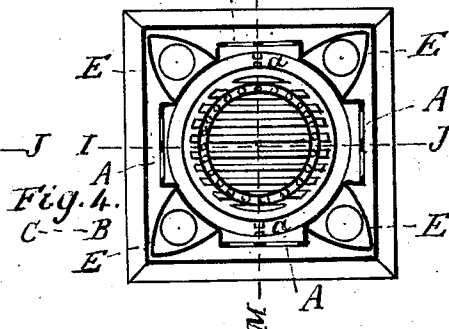
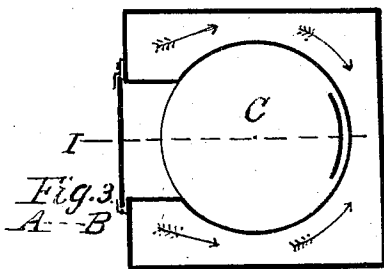
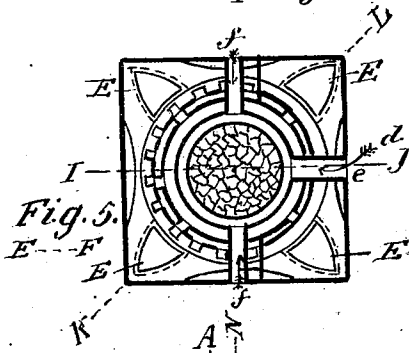
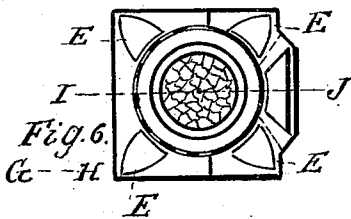
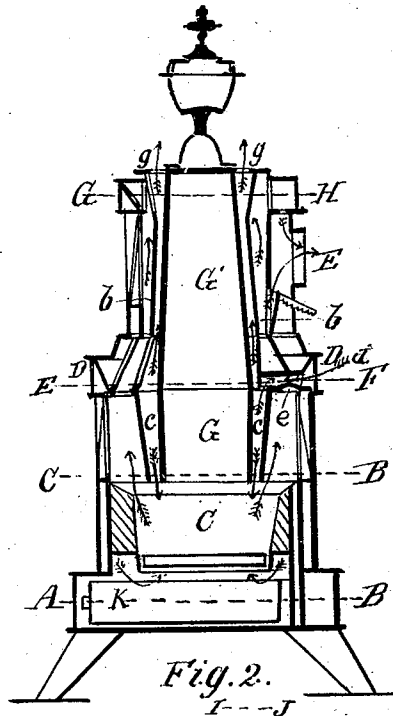
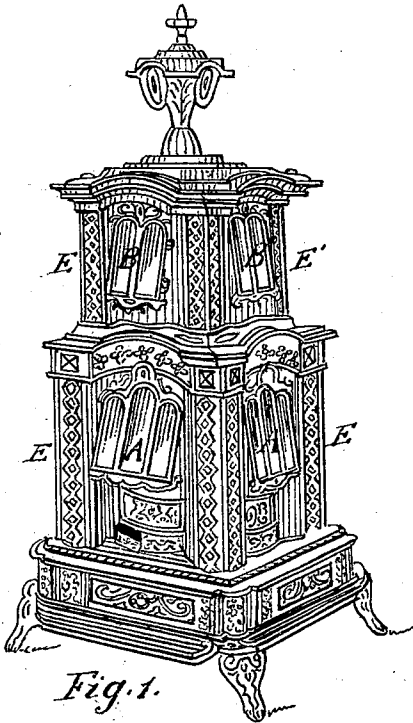

Witnesses
J. H. Coul
Jno. D. Patton

Inventor
Albert C. Corse—By
Thomas P. Horton
his attorney

A. C. CORSE;
Magazine Stove.

No. 107,597.

Patented Sept. 20, 1870.

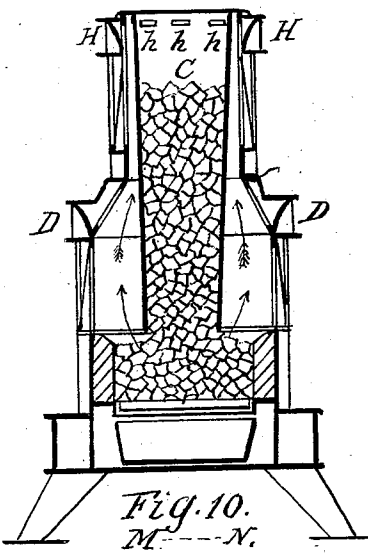
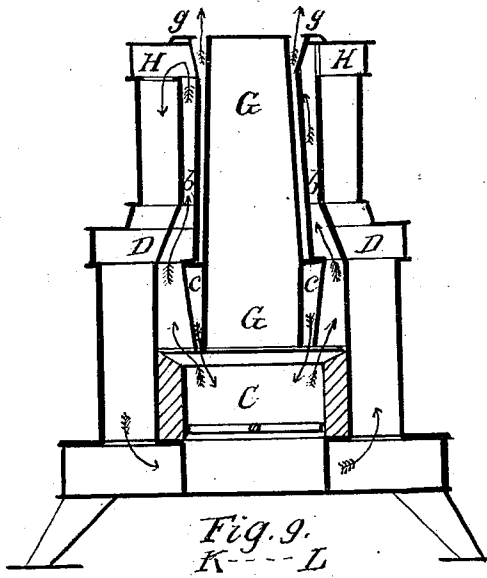
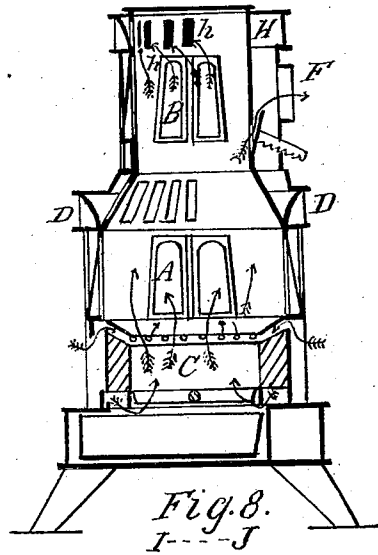
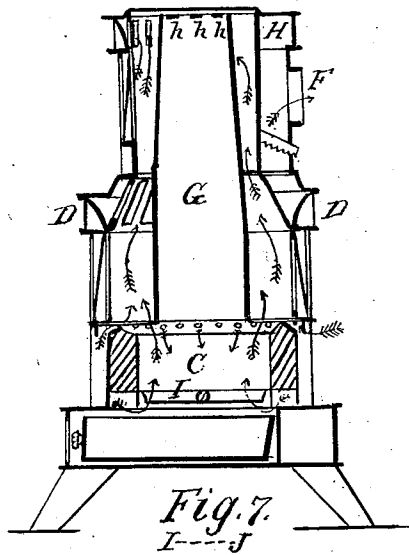

Witnesses
D. R. Cook
Jno D. Patten

Inventor
Albert C. Corse - By
Marcus Barton
his attorney

United States Patent Office.

ALBERT C. CORSE, OF TROY, NEW YORK.

Letters Patent No. 107,597, dated September 20, 1870.

IMPROVEMENT IN BASE-BURNING COAL-STOVES.

The Schedule referred to in these Letters Patent and making part of the same.

To all whom it may concern:

Be it known that I, ALBERT C. CORSE, of the city of Troy, county of Rensselaer and State of New York, have invented new and useful Improvements in "Base-burning and Heating-Stoves;" and I do hereby declare that the following is a full, clear, and exact description of the nature, construction, and operation of the same, reference being hereby had to the accompanying drawing and to the letters of reference marked thereon, and making a part of this my specification.

Like letters represent and refer to like or corresponding parts.

Figure 1 is a perspective view of a base and coal-burning and heating-stove, containing my invention and improvements herein described and set forth.

Figure 2 represents a vertical section of such stove, on a center line from the front to the rear thereof, through the exit and chimney-pipe.

Figures 3, 4, 5, and 6 are cross-sections through certain parts of said stove.

Figure 7 is a vertical section, showing a coal-supply cylinder, having no surrounding air-space or chamber, such as is shown at fig. 2.

Figure 8 is a vertical section, showing the coal-supply cylinder removed, for the purpose of viewing the inside arrangement of the mica windows.

Figure 9 is a vertical section on a line from one corner of the vertical corner flues to the corner of another corner flue, opposite the same in a diagonal line or direction, and showing a double coal-supply cylinder, having, surrounding the same, an air-space or chamber.

Figure 10 also shows a vertical section, having therein a coal-supply cylinder without any surrounding chamber, and made in a tapering form, the lower end of the same being less in diameter. It is also supplied with coal fuel, showing the operation of the same.

Figs. 2, 7, and 9 have coal-supply cylinders of tapering form, but the upper end is of less diameter than the lower end, from which coal is supplied to the fire below in a more free manner.

The self-feeding device or apparatus to receive and contain the coal to supply combustion, and for warming or heating the air in the manner herein set forth, is constructed, as shown at fig. 2, with an annular or surrounding chamber, so divided as to form two chambers, substantially as shown at fig. 9. The lower chamber is for the purpose of supplying heated air to the surface of the burning fuel, whereby to promote combustion of the fuel, and to economize in the use of the same. The upper surrounding chamber is for the purpose of heating the air to be supplied to the surrounding room from the top of the stove, and each chamber will, in a great degree, protect and preserve

the inner cylinder from being burned out too rapidly in the use of the same, for there will be a continuous circulation of air in each of said chambers.

The nature of my invention and improvements consists in the arrangement of a double supply-cylinder within an annular or surrounding chamber, and vertical corner flues, supporting an upper annular or surrounding chamber, from which is suspended the fuel-supply cylinder, and into which chamber pass the escaping gases or products of combustion arising within such supply-cylinder, and passing through suitable openings at or near the top of said fuel-supply cylinder, in the manner substantially as herein described and set forth.

It also consists in the arrangement and combination of a fuel-supply-cylinder, having suitable openings at or near the upper end thereof, upon and within an annular or surrounding chamber at the immediate top of the stove, so that any escaping gases or products of combustion shall pass into such surrounding chamber, and thence, down vertical flues, into the fire-chamber below.

I construct my stove herein with an upper and lower section, each having vertical corner flues, four in number, and an annular and surrounding chamber, substantially as shown at fig. 1 of said drawing.

In the lower section, which is some larger than the upper section in all of its various parts, I construct the fire or combustion-chamber, and immediately over the same I arrange and suspend, from the said upper section, the coal or fuel-supply cylinder. Between the said upper and lower sections I construct and arrange the intermediate annular chamber, for the purpose of receiving the heated air and conducting the same into corner flues, connected with said lower section, and which connect or communicate with the flue or chamber in the base of the stove.

At the top of the upper section I construct and arrange an annular or surrounding chamber, which rests upon the top of the vertical corner flues belonging to that section, and which is for the purpose of receiving the heated air or escaping gases or products of combustion which may come from the top of the fuel-supply cylinder, through openings in the same, and then conducting the same into and through the vertical corner flues, combined with such section, into the fire-chamber space below. From the top of the said upper section, and immediately upon the top of the annular surrounding chamber, will be suspended, arranged, and combined the coal or fuel-supply cylinder, upon and over which there is an urn, covering the opening into the said cylinder for the receiving of the replenishing fuel.

E are the vertical corner flues of the lower section. These are four in number.

C is the fire or combustion-chamber, and it is arranged just below the fuel-supply cylinder, and between the said corner vertical flues, and below the annular chamber, intermediate the said corner flues of the upper and lower sections.

Each of said corner flues of the lower section opens into a flue-space or chamber in the base of the stove, just below the chamber of combustion, which their upper ends open into the said middle annular chamber D, which is supported upon the upper ends of said flues, and which has an arch upon each side, and one each of the mica windows A, in the section below, substantially as shown in the drawing.

I construct the upper section of the said stove with a cylinder or chamber, upon the outside of which are four corner and vertical flues, E', which are somewhat smaller than the corner flues E of the section below.

In their respective vertical positions the lower end of each will open into said annular chamber D, while, at their upper ends, each will open into the upper annular and surrounding chamber H.

The heat from the fire-chamber passes, from the space surrounding the coal or fuel-supply cylinder, suspended therein, substantially as shown in said drawing, into the said front corner flues and front part of said intermediate surrounding chamber D, through and down the same, into and through the space or chamber within the base, and thence up the rear corner flues, into the rear part of said chamber D, and thence away into the exit-flues, through the chamber connected with the exit-flue F.

The heat or escaping gases arising within the coal or fuel-supply cylinder suspended from the top of the upper annular chamber H, and between the corner-flues E', and also within the intermediate annular chamber D, and also within the central part and upper portion of said lower corner flues E, will pass upward, through the same, from the burning fuel below, and out through the openings *h*, figs. 7, 9, and 10 of said drawing, and into the surrounding space, and from thence into the said upper annular chamber H, and into and down the said upper corner flues E', and from thence being returned to the space or chamber of combustion immediately over the said fire-chamber C, and surrounding the lower end of said suspended coal or fuel-supply cylinder, and will then become ignited, adding to the heat already attained, and preventing any explosion or injurious effect of or about said fuel-supply cylinder. There is, therefore, a full and free escape of all the gases that may arise with the said coal or fuel-supply cylinder, by reason of the burning fuel in the combustion-chamber C, and just at the lower end of the said supply-chamber or cylinder.

Within said stove, within the said upper annular chamber H, and suspended from the immediate top of the same, and within the central part of the said upper corner flues E', and within the intermediate annu-

lar chamber D, and within the central part or portion of the said lower corner flues E, and above the fire or combustion-chamber C, occupying about one-half the height of the said corner flues E, I construct and arrange a coal or fuel-supply cylinder or chamber, substantially as shown in the accompanying drawing, at figs. 7 and 10, having the suitable gas-escaping apertures or opening *h*.

I also thus construct and arrange a coal or fuel-supply cylinder or chamber, having outside, and surrounding the same, two air-heating chambers or flue-spaces, *b* and *c*, figs. 2 and 9. The said supply-cylinder and said air-chambers *b* and *c* are each constructed and arranged in the manner substantially as shown at said figs. 2 and 9. The said supply-cylinder, thus constructed, may be seen at G and G' of the said drawing.

Atmospheric air is admitted to chamber *b* by means of and through the air-tubes *f f*, fig. 5, and, becoming highly heated therein, passes up the same, and out into the room through openings in the top covering-plate.

Atmospheric air is admitted into the chamber C through the tube *e*, figs. 2 and 5, and passing into such space or chamber, it becomes somewhat heated before entering the fire in the fire-chamber C, through the openings or apertures *d d*, figs. 2 and 5 of said drawing, and thereby prevents, in a measure, the too rapid burning out of that part of said double supply-cylinder, and also enters among the evolving gases, and aids combustion.

I do not claim as my invention, nor do I desire Letters Patent upon the stove, the supply-cylinder, and the several features shown and described, when separately considered; but

What I do claim as my invention, and hereby desire Letters Patent thereon, is—

1. The arrangement of the coal or fuel-supply cylinder G and G' within the annular chamber D, and intermediate the vertical corner flues E and E', and in combination with the upper annular chamber H, in the manner and for the purposes substantially as herein described and set forth.

2. A coal or fuel-supply cylinder or reservoir, G, having therein openings *h*, at or near the top of the same, and suspended at and from the immediate top of the annular and upper surrounding chamber H, and within the upper section of the stove, in combination with the upper annular chamber or flue H and the upper vertical corner flues E', in the manner and for the purposes substantially as herein described and set forth.

In testimony whereof I have, on this 14th day of December, 1869, hereunto set my hand.

ALBERT C. CORSE.

Witnesses:

MARCUS P. NORTON,
AUG. P. CORSE.