

S.A. Bell.

Water Wheel.

No 92,252.

Patented July 6. 1869.

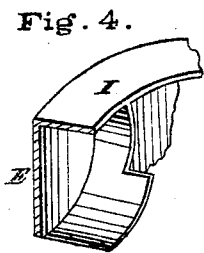
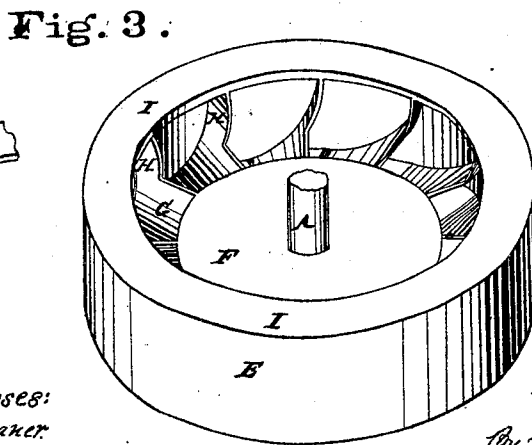
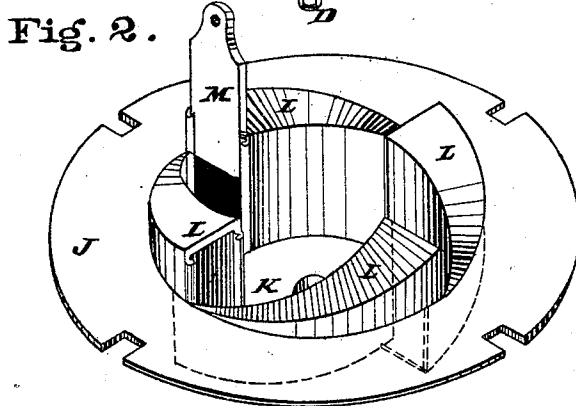
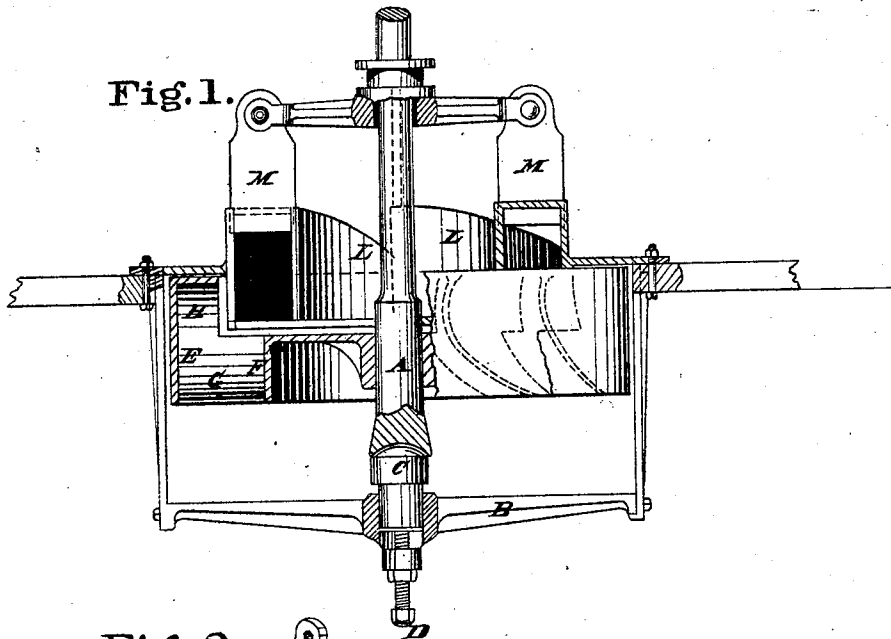

Witnesses:
Charles Baner
Charles Hofjames

Inventor:
Stephen A. Bell
By Frank Miller and
Attorney

United States Patent Office.

STEPHEN A. BELL, OF NEWTOWN, OHIO.

Letters Patent No. 92,252, dated July 6, 1869.

IMPROVEMENT IN TURBINE WATER-WHEELS.

The Schedule referred to in these Letters Patent and making part of the same.

To all whom it may concern:

Be it known that I, STEPHEN A. BELL, of Newtown, Hamilton county, State of Ohio, have invented certain new and useful Improvements in Water-Wheels; and I do hereby declare the following to be a sufficiently full, clear, and exact description, to enable one skilled in the art to which my invention appertains, to make and use it, reference being had to the accompanying drawings, which form a part of this specification.

My invention consists—

First, in a peculiar construction of stationary cover or cap, by which such a free influx of water is provided for, and maintained, such direction given to the current, and the flow so governed, that the water impinges upon the wheel in a direction and volume, most favorable for as full realization of power as possible, and the supply be governed easily and effectually under all conditions of size of wheel, head of water, &c.

Second, in a peculiar construction of the rim and buckets of the revolving wheel, particularly designed and adapted to be used in connection with the cover alluded to in the foregoing clause.

In the accompanying drawings—

Figure 1 is an axial section of cover, wheel, and attachments.

Figure 2 is a perspective view of the cover detached.

Figure 3 is a perspective view of the wheel.

Figure 4 is a view of a portion of the wheel, showing the shape of bucket.

The shaft A, to which the revolving wheel is attached, is supported by the customary spider B, and revolves on the "nigger-head" or inverted step, C, which is provided with a set-screw, D, for the requisite adjustment of the wheel.

The rim E of the wheel is connected to the hub F by the buckets G.

That portion of the buckets G, which is below the face of the hub F, is of the customary form, but in addition to this, I project a portion of each blade up-

ward, and join this extension (which is designated in the drawing by letter H) to a horizontal flange, I, of the same width as the extension H. This extension is devised to receive the direct impact of the water before it is permitted to act upon the bucket proper, G.

The cover of the wheel (see fig. 2) has a flange, J, against the under side of which the flange I comes in contact, and a pit, K, is formed within the cover, whose bottom is in close contact with the upper face of the hub F.

Around the sides of the pit K, conduits, L, are formed, whose outer sides, which project above the face of the cover, are concentric with the cover, and the inner sides, which extend both above and below the face of the cover, eccentric. The top plates of the conduits incline from the mouth to the face of the cover.

The mouth of each conduit is governed by a sliding gate, M, which, under all conditions, is capable of governing the flow of water to the wheel. The customary penstock is built round the wheel above the cover.

The provision of the pit K and connecting-conduits L, gives a free central entry for the water, and a direction of current toward the buckets horizontally. The extension H, and flange I, in connection with rim E, form a pocket, in which the direct force of the water is expended, without chance of escape.

I claim herein as new, and of my invention—

1. The provision of the pit K, and connecting-conduits L, in the stationary cover, constructed and operating substantially in the manner and for the purpose specified.

2. In the described combination with the elements of the preceding clause, the bucket-extension H and flange I, for the purpose described.

In testimony of which invention, I hereunto set my hand.

STEPHEN A. BELL.

Witnesses:

THEO. H. JAMES,
CHARLES BAUER.