

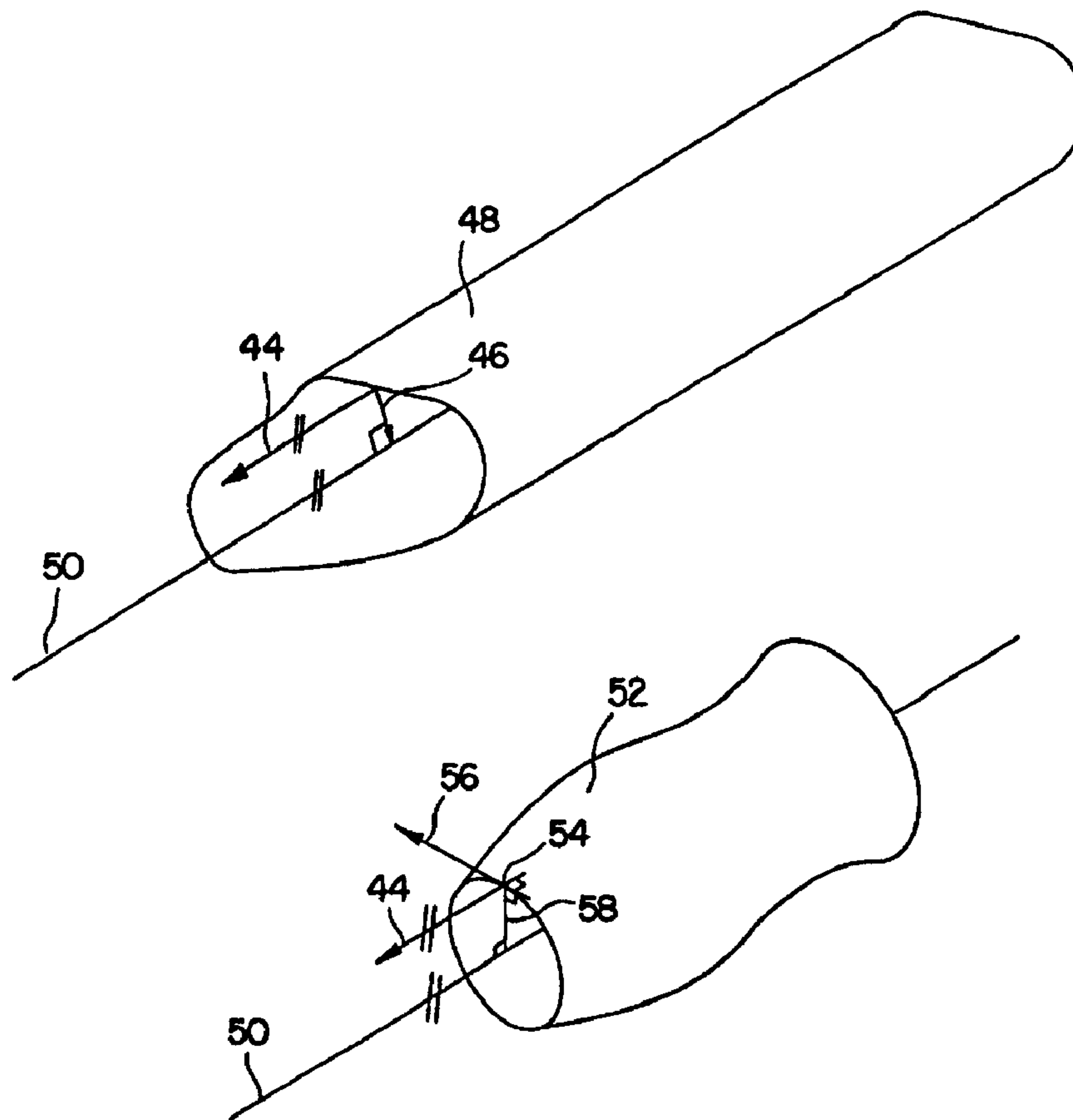

(86) Date de dépôt PCT/PCT Filing Date: 1995/10/27
 (87) Date publication PCT/PCT Publication Date: 1996/05/17
 (45) Date de délivrance/Issue Date: 2002/07/30
 (85) Entrée phase nationale/National Entry: 1997/03/19
 (86) N° demande PCT/PCT Application No.: CA 1995/000613
 (87) N° publication PCT/PCT Publication No.: 1996/014597
 (30) Priorité/Priority: 1994/11/02 (08/333,340) US

(51) Cl.Int.⁶/Int.Cl.⁶ G02B 6/10, F21V 8/00
 (72) Inventeur/Inventor:
 WHITEHEAD, LORNE A., CA
 (73) Propriétaire/Owner:
 THE UNIVERSITY OF BRITISH COLUMBIA, CA
 (74) Agent: OYEN WIGGS GREEN & MUTALA

(54) Titre : GUIDE DE LUMIERE CREUX POUR LUMIERE DIFFUSE
 (54) Title: HOLLOW LIGHT GUIDE FOR DIFFUSE LIGHT



(57) Abrégé/Abstract:

An outer prism light guide (48) surrounds a cover (52) which in turn surrounds a light source. Guide (48) is formed of prism light guide wall material having uniform shape in cross sections perpendicular to a first octature symmetry direction (44), with its

(57) **Abrégé(suite)/Abstract(continued):**

optical centre line (50) parallel to direction (44). Surfaces of the wall material are substantially in octature relative to direction (44). A surface normal vector (46) at any point on any internal surface of the material is either substantially parallel or substantially perpendicular to a first notional line extending from the point through and perpendicular to optical centre line (50). Cover (52) has cylindrical symmetry about optical centre line (50) to intercept a substantial portion of light emitted by the source. Cover (52) is formed of prism light guide wall material, with surfaces of the cover wall material substantially in octature at any point (54) on cover (52) relative to a second, spatially variable octature symmetry direction (56), which, at point (54), is perpendicular to first octature symmetry direction (44); and, perpendicular to a second notional line (58) extending from point (54) through and perpendicular to optical centre line (50). A surface normal vector at any point on any outer surface of cover (52) is either substantially parallel or substantially perpendicular to first octature symmetry direction (44). Cover (52) is confined to a region sufficiently close to optical centre line (50) to substantially prevent propagation of light rays incident on an inside surface of cover (52) to and through the light guide wall material.



INTERNATIONAL APPLICATION PUBLISHED UNDER THE PATENT COOPERATION TREATY (PCT)

<p>(51) International Patent Classification⁶ : G02B 6/42, F21V 8/00</p>	<p>A1</p>	<p>(11) International Publication Number: WO 96/14597 (43) International Publication Date: 17 May 1996 (17.05.96)</p>
---	------------------	--

<p>(21) International Application Number: PCT/CA95/00613 (22) International Filing Date: 27 October 1995 (27.10.95) (30) Priority Data: 08/333,340 2 November 1994 (02.11.94) US (71) Applicant: THE UNIVERSITY OF BRITISH COLUMBIA [CA/CA]; Industry Liaison Office, IRC Building, Room 331, 2194 Health Sciences Mall, Vancouver, British Columbia V6T 1Z3 (CA). (72) Inventor: WHITEHEAD, Lorne, A.; 3015 West 12th Avenue, Vancouver, British Columbia V6K 2R4 (CA). (74) Agent: WIGGS, Blake, R.; Oyen Wiggs Green & Mutala, 480-601 West Cordova Street, Vancouver, British Columbia V6B 1G1 (CA).</p>	<p>(81) Designated States: CA, CN, JP, NO, European patent (AT, BE, CH, DE, DK, ES, FR, GB, GR, IE, IT, LU, MC, NL, PT, SE). - 2200441 Published With international search report.</p>
--	---

(54) Title: HOLLOW LIGHT GUIDE FOR DIFFUSE LIGHT

(57) Abstract

An outer prism light guide (48) surrounds a cover (52) which in turn surrounds a light source. Guide (48) is formed of prism light guide wall material having uniform shape in cross sections perpendicular to a first octature symmetry direction (44), with its optical centre line (50) parallel to direction (44). Surfaces of the wall material are substantially in octature relative to direction (44). A surface normal vector (46) at any point on any internal surface of the material is either substantially parallel or substantially perpendicular to a first notional line extending from the point through and perpendicular to optical centre line (50). Cover (52) has cylindrical symmetry about optical centre line (50) to intercept a substantial portion of light emitted by the source. Cover (52) is formed of prism light guide wall material, with surfaces of the cover wall material substantially in octature at any point (54) on cover (52) relative to a second, spatially variable octature symmetry direction (56), which, at point (54), is perpendicular to first octature symmetry direction (44); and, perpendicular to a second notional line (58) extending from point (54) through and perpendicular to optical centre line (50). A surface normal vector at any point on any outer surface of cover (52) is either substantially parallel or substantially perpendicular to first octature symmetry direction (44). Cover (52) is confined to a region sufficiently close to optical centre line (50) to substantially prevent propagation of light rays incident on an inside surface of cover (52) to and through the light guide wall material.

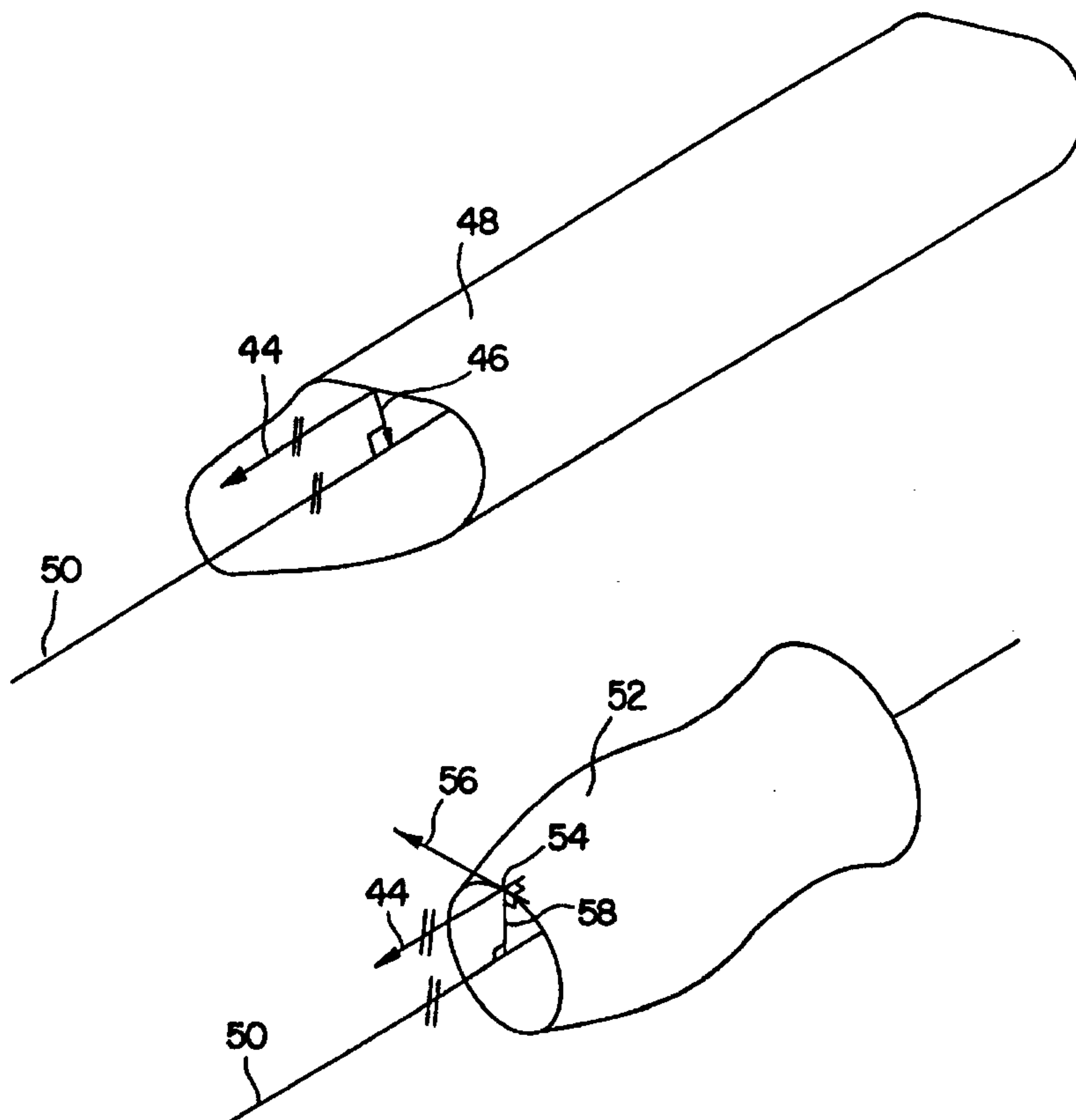

HOLLOW LIGHT GUIDE FOR DIFFUSE LIGHT

Field of the Invention

This invention allows the light output of a large diffuse light source to be coupled into a prism light guide such that most of the light is confined in and guided along the guide, with only insignificant amounts of light escaping from the guide in the vicinity of the light source.

Background of the Invention

Light guides can be divided into two basic categories. The first, and best known, is solid light guides whose cross-sectional area is composed entirely of a guidance medium. Optical fibres, and larger analogous structures, are of this type. They achieve high efficiency because light is guided by total internal reflection, a non-absorptive process.

The second major category is hollow light guides, which can be more practical because they can guide more light using less material. For example, hollow metallic light guides confine and guide light by means of metallic reflection, which is an absorptive process. More recently, prism light guides have been used to confine and guide light. These are hollow structures which achieve total internal reflection by means of careful arrangement of prismatic surfaces on the exterior of the prism light guide's transparent dielectric wall material. Although prism light guides are more efficient than metallic light guides, they suffer from a serious drawback: they are only able to guide light which falls within a limited range of angles relative to the prismatic surfaces.

It is often possible to collimate the light output of a small light source with a reflector so that essentially all of the reflected light rays satisfy the angular relationship necessary to ensure that essentially all such rays undergo total internal reflection as they propagate along the light guide. But, there are some situations where this is difficult; for example, if the light output of a large diffuse light source is to be coupled into a prism light guide.

- 2 -

In residential lighting applications, for example, it is desirable to couple the light output of comparatively large compact florescent lamps into comparatively small prism light guides; and, in commercial lighting applica-
5 tions, it is desirable to couple light output from radio frequency induction florescent lamps into somewhat larger light guides. In these cases the diffuse light source is too large to allow sufficient collimation by a reflector to ensure that all of the reflected light rays satisfy the
10 angular relationship aforesaid so as to ensure that essentially all such rays undergo total internal reflection as they propagate along the light guide. Consequently, a substantial portion of the light rays emitted by the diffuse light source escape immediately from the light
15 guide in the vicinity of the light source, creating undesirable brightness in that vicinity, and reducing the intensity of the light which remains to be guided along the full extent of the light guide.

The present invention provides a means for coupling
20 the light output of a relatively large diffuse light source into a relatively smaller prism light guide such that most of the light is confined within and guided along the light guide, with only insignificant amounts of light escaping from the guide in the vicinity of the light source.

25 Summary of the Invention

In accordance with the preferred embodiment, the invention provides a light guide containing a light source. The light guide consists of an outer prism light guide surrounding a cover which in turn surrounds the light
30 source. The outer prism light guide is formed of prism light guide wall material having uniform shape in cross-sections perpendicular to a first octature symmetry direction, and having an optical centre line parallel to the first octature symmetry direction. Surfaces of the light
35 guide wall material are substantially in octature relative to the first octature symmetry direction; and, a surface normal vector at any point on any internal surface of the

- 3 -

material is either substantially parallel or substantially perpendicular to a first notional line extending from the point through and perpendicular to the optical centre line. The cover is positioned within the guide, around the light source, in cylindrical symmetry about the optical centre line, to intercept a substantial portion of light emitted by the source. The cover is formed of prism light guide wall material, with surfaces of the cover wall material substantially in octature at any point on the cover relative to a second, spatially variable octature symmetry direction, which, at the point, is perpendicular to the first octature symmetry direction; and, perpendicular to a second notional line extending from the point on the cover through and perpendicular to the optical centre line. A surface normal vector at any point on any outer surface of the cover is either substantially parallel or substantially perpendicular to the first octature symmetry direction. The cover is confined to a region sufficiently close to the optical centre line to substantially prevent propagation of light rays incident on an inside surface of the cover to and through the light guide wall material.

Advantageously, the cover forms a cylinder of length "l" and diameter "d", with "l" being less than the light guide's length dimension and with each end of the cylinder extending more than 1.65 times the diameter "d" beyond the light source.

The light guide may also form a cylinder. For example, the light guide and the cover may form partial concentric cylinders truncated by a planar metallic reflector which intersects the optical centre line.

A light extraction mechanism may be provided to controllably emit light at selected points along the guide, with end reflector means being provided to prevent light emission through either opposed end of the guide.

35 Brief Description of the Drawings

Figure 1 is a pictorial illustration of a prior art prismatic light guide.

Figure 2 is a greatly enlarged, pictorial illustration of a segment of prismatic light guide wall material intersected by two notional planes and an incident light ray which defines a third notional plane.

5 Figure 3 is a cross-sectional elevation of a prismatic light guide having a well collimated light source.

Figure 4 illustrates the difficulty of coupling the light output of a comparatively large light source into a comparatively small prism light guide.

10 Figure 5 is a cross-sectional end view of a prismatic light guide and illustrates a phenomenon whereby light rays originating from specific locations relative to the light guide are confined and guided along the light guide irrespective of their angle relative to the light guide's axis
15 direction.

Figure 6 is similar to Figure 2, but utilizes a Cartesian coordinate system.

Figure 7 is a graph which plots the range of angles for which prism light guide wall material produces total
20 internal reflection using the Cartesian coordinates of Figure 6.

Figure 8 is a partially fragmented pictorial illustration of a non-absorptive means for preventing light rays emitted by a diffuse light source from entering the non-
25 total internal reflection (i.e. non-shaded) zone of Figure 7.

Figure 9 is a graph which plots, in the Cartesian coordinates of Figure 6, the appearance of a diffuse light source surrounded by the cylindrical structure of Figure 8,
30 when viewed from a distance from the cylinder's axis equal to 3.2 times the cylinder's radius.

Figure 10 shows the Figure 9 light escape zone of the diffuse light source covered by the Figure 8 structure, superimposed on the Figure 7 depiction of the total internal
35 reflection zone of prism light guide wall material.

Figure 11 is a cross-sectional elevation of a prism light guide having a diffuse light source surrounded by a cylindrical cover of the type shown in Figure 8.

Figure 12 is a partially fragmented pictorial illustration of a structure similar to that depicted in Figure 11, but with light guide and cylindrical cover truncated.

Figure 13 is a cross-sectional elevation depicting four different prismatic structures which all satisfy the "octature" requirement characteristic of material suitable for forming a prism light guide.

Figure 14 is a cross-sectional elevation of a planar prism light guide conforming to the invention.

Figures 15(a), 15(b) and 15(c) depict three different shapes of prism light guide wall material, and the two vectors which characterize those shapes.

Figure 16 depicts a generalized prism light guide.

Figure 17 depicts a generalized form of non-absorptive means for preventing light rays emitted by a diffuse light source from entering a non-total internal reflection zone.

20 Detailed Description of the Preferred Embodiment

Figure 1 depicts an exemplary prior art prismatic light guide 10, which happens to be of circular cross-section. The exterior, transparent dielectric wall material 12 of light guide 10 bears a plurality of prismatic surfaces 14. As indicated above, prism light guides are only able to guide light which falls within a limited range of angles relative to the prismatic surfaces. Such rays undergo "total internal reflection", meaning that they remain confined within the guide and propagate along the guide as they are repeatedly reflected by the prism light guide wall material.

For prism light guides, the direction of incidence of a given light ray relative to the prismatic wall material is what determines whether that ray will undergo total internal reflection. This can be described in terms of the angles θ and ϕ shown in Figure 2, which depicts a segment 12' of transparent dielectric wall material bearing pris-

matic surfaces 14'. Segment 12' is perpendicularly intersected by a first notional plane P_1 parallel to prismatic surfaces 14' and by a second notional plane P_2 transverse to prismatic surfaces 14'. The light ray R defines a third
 5 notional plane P_3 which intersects plane P_1 at an angle ϕ , with the ray R intersecting the perpendicular bisector of planes P_1 , P_2 at an angle θ . It can be shown that light rays will undergo total internal reflection for all values of ϕ , provided that θ is less than a critical angle θ_c given
 10 by the following equation:

$$\theta_c = \cos^{-1} \sqrt{1 - (\eta^2 - 1) \left(\frac{2 - \sqrt{2}}{2 + \sqrt{2}} \right)} \quad (1)$$

where η is the refractive index of the material. For example, for a typical value of η of 1.6 (for polycarbonate material), θ is approximately 30° .

15 As depicted in Figure 3, it is often possible to collimate the light output of a small light source 16 with a reflector 18 so that essentially all of the reflected light rays R come within 30° of the axis direction of prism light guide 10, thus ensuring that essentially all such
 20 rays undergo total internal reflection as they propagate along guide 10.

As shown in Figure 4, it is difficult to couple the light output of a comparatively large light source 16' into a comparatively small prism light guide 10. Light source
 25 16' is too large to allow sufficient collimation by reflector 18 to ensure that all of the reflected light rays R satisfy the constraint of equation (1) so as to ensure that essentially all such rays undergo total internal reflection as they propagate along guide 10. Consequently, a substantial
 30 portion of the light rays R' emitted by light source 16' escape immediately from guide 10 in the vicinity of source 16', creating undesirable brightness in that vicin-

ity, and reducing the intensity of the light which remains to be guided along the full extent of guide 10.

An important additional consideration is that in certain cases prism light guides can confine and guide
5 light rays which come within any angle relative to the guide's axis direction, provided such rays originate from specific locations relative to such guides. Figure 5 depicts an example of this phenomenon for a circular cross-sectioned prism light guide 10' containing a notional
10 cylinder 20 having a diameter "d". It can be shown that, for prism light guide wall material having a refractive index of 1.6, all light rays passing through cylinder 20 are reflected by the prism light guide wall material as long as the diameter "d" of cylinder 20 is less than or
15 equal to 17.6% of the diameter of the circular prism light guide. The reason this phenomenon holds true is that as long as light rays pass through cylinder 20, the value of ϕ as described above in relation to Figure 2 will always be less than 10.1° , which ensures reflection for all values of
20 θ .

Thus, if a diffuse light source is located within cylinder 20, all light rays emitted by that source will be confined and guided by the prism light guide. Unfortunately, since the cross-sectional area of cylinder 20
25 represents only 3% of the cross-sectional area of guide 10', the foregoing phenomenon is of little practical advantage. Indeed, if a diffuse light source of that size were available, one could simply use a conventional reflector to efficiently collimate the light output of that
30 source, as described above in relation to Figure 3. Nevertheless, the phenomenon suggests that it may be possible to take advantage of the special angular characteristics of prism light guide wall material to achieve light guidance beyond the normal collimation restrictions.

35 To understand this better, it is helpful to refer to Figure 6, which provides a more useful depiction of the range of directions for which prism light guide wall

material will create total internal reflection. Figure 6 uses a different means of describing the direction of light incident on prism light guide material 12', which is better adapted to diagrammatical representation on a plane surface. Figure 6 depicts the same geometry as Figure 2, but using a Cartesian coordinate system. The incident ray R has a unit vector (x, y, z) , and in this depiction the two dimensional description of direction which is helpful is x/y , which depicts the deviation of ray R from normal to the light guide wall, in a direction perpendicular to prisms 14'; and z/y , which depicts deviation from the perpendicular to the light guide wall in the direction parallel to prisms 14'.

The relationship between ϕ , θ , x/y and z/y is given by:

$$x/y = \tan\phi \quad (2)$$

$$z/y = \left(\frac{1}{\cos\phi \tan\theta} \right) \quad (3)$$

Using the Figure 6 coordinate system, Figure 7 plots the range of angles for which prism light guide wall material produces total internal reflection. One of the reasons that this depiction is helpful is that it is a projection onto a plane of precisely what one sees when one looks into a sheet of prism light guide wall material; that is, Figure 7 shows the visual appearance of the zone of total internal reflection (shaded area) versus the zone of transmission (non-shaded area).

Figure 7 illustrates three important features. First, when $z/y = 0$ (i.e. when the ray is in the plane perpendicular to the axis of the light guide, that is when $\theta = 90^\circ$), it can be seen that the width of the total internal reflection zone is rather narrow (i.e. $x/y = \pm 0.179$, which is the value of $\tan\phi$, so $\phi = \pm 10.1^\circ$). The second import-

ant feature is the asymptote where both z and x are much larger than y , in which case $x/z \approx \tan \theta_c$. The slope of this asymptote is 0.605, which corresponds to a value of $\theta_c = 31.1^\circ$, which is the maximum value of θ for which all values of ϕ result in reflection.

The present invention provides a non-absorptive means of preventing light rays emitted by a diffuse source from entering the non-total internal reflection (i.e. non-shaded) zone of Figure 7. The invention in its simplest form (Figure 8) consists of surrounding the diffuse source with a hollow transparent cylinder 22 having a smooth outer surface 24 and having an inner surface consisting of a large number of right angle prisms 26 which extend perpendicular to the axis of cylinder 22. Cylinder 22 can be made, for example, from the same prismatic sheet material used to form prism light guides, by orienting the prisms differently (i.e. in a light guide the prisms face outwardly and extend parallel to the guide's axial direction).

As an illustrative example, consider the case where cylinder 22 surrounds a diffuse light source such as a florescent tube. Figure 9 shows how such a source would appear when viewed from a distance from the cylinder's axis equal to 3.2 times the cylinder's radius (the reason for this choice of distance is clarified below). In a lengthy but straightforward calculation, the appearance shown can be calculated from the characteristics of prism light guide wall material. Looking at the centre of the cylinder, one perceives an opaque zone (shaded area in Figure 9) of width ± 0.179 , which is the normal opaque zone at normal incidence of prism light guide wall material. The familiar shape of this total internal reflection zone is distorted by the curvature of the prism light guide wall material, into the shape shown. It is important to note that light rays which are not transmitted by the prism light guide wall material due to the prismatic covering, are reflected back toward the diffuse source, where they may be re-reflected randomly, so that they have a secondary opportunity to escape in

- 10 -

allowed directions. Therefore, little light is lost by this prismatic covering, assuming that the source is not very absorptive, as is often the case. It is also important to note that providing that prism light guide wall material is of good optical quality, essentially no light is present in the total internal reflection zone of Figure 9.

The reason for the specific choice of viewing distance for Figure 9 can now be explained in relation to Figure 10. In Figure 10, the light escape zone of the diffuse light source covered by the Figure 8 structure as shown in Figure 9, is superimposed on a depiction of the total internal reflection zone of prism light guide wall material shown in Figure 7. As can be seen, none of the light rays escaping from the covering of the diffuse source lie outside the total internal reflection zone of the prism light guide itself, so they are all confined and guided. In the most common case where the refractive index of the prism light guide wall material is 1.6, this occurs for a diffuse cylinder having a diameter of 32% of the diameter of the prism light guide, which corresponds to an area of 10% of the cross-sectional area of the prism light guide itself. It should be noted that this is a 3.2-fold increase in the cross-sectional area, compared to that which would be possible without such a prismatic covering, and which allows a corresponding increase in the amount of light which can be carried by a light guide of a given size.

Figure 11 shows how the foregoing concept can be adapted to a simple lighting product. In Figure 11 a diffuse light source 28 is surrounded by a cylinder 30 of the type shown in Figure 8. Cylinder 30 is sufficiently long that light rays which pass directly from source 28 out the ends of cylinder 30 lie within the total internal reflection zone of the wall material forming prism light guide 32, without any need for further optical correction. The diameter of cylinder 30 is 32% of the diameter of prism light guide 32. Prism light guide 32 contains extraction

- 11 -

mechanisms (not shown) to cause uniform escape of light over the length of guide 32. The ends of guide 32 are capped with mirrors (not shown) for capturing light which propagates all the way to the end of the guide, so that all
5 the light is efficiently utilized.

The parameters which govern the coupling of diffuse light sources to prism light guides are much more general than the simple preceding example suggests. For example, neither cylinder 30 nor prism light guide 32 need be fully
10 circular in cross-section. As shown in Figure 12, they may be partly circular in cross-section, with the remainder truncated by a conventional metal reflector 34.

Furthermore, although the transparent dielectric material most commonly used to form the walls of a prism
15 light guide has isosceles right triangle prisms of the type shown in Figures 2 and 5, the optical principles which characterize prism light guides are not restricted to simple isosceles right triangle prisms. In general, the prism light guide wall material need only have surfaces
20 which are in "octature", that is:

1. all surfaces are parallel to an octature symmetry direction (such as the z direction in the example of Figures 1 and 2);
 2. all inner surfaces extend at right angles to one another;
25 other;
 3. all outer surfaces extend at right angles to one another; and,
 4. inner and outer surfaces extend at 45° to one another.
- For example, Figure 13 depicts four different prismatic
30 cross-sections, all of which satisfy the octature requirement, all of which are suitable wall material for forming a prism light guide, and all of which have total internal reflection zones different than that shown in Figure 7. By employing a structure which has octature throughout, but in
35 which the prismatic shape varies as a function of position, it is possible to capture the geometrical concepts of the invention in cross-sections which are not circular. For

- 12 -

example, Figure 14 shows a planar prism light guide 36 having a diffuse light source 38 surrounded by a cylindrical cover of the type described above in relation to Figure 8. The Figure 14 structure achieves the same performance as the Figure 11 structure because of the detailed shape of the prisms as shown.

A fully generalized characterization of the invention must take into account both the microscopic and macroscopic structure of prism light guide wall material. The following discussion presents a simplified method of describing the microscopic structure of prism light guide wall material at any given point in reference to simple well-defined macroscopic lines and directions. This facilitates characterization of the invention in general.

Figures 15(a), 15(b) and 15(c) each depict a small piece of prism light guide wall material 40 which is sufficiently large that it bears several complete prisms 42, but is sufficiently small that for all practical purposes the material is macroscopically flat and prisms 42 are uniform in shape over the extent of the piece. The shape of material 40 is characterized by just two vectors.

An "octature symmetry direction" vector 44 defines the direction of longitudinal extent of prisms 42. The octature symmetry direction must be parallel to the macroscopic surface of material 40, but otherwise can have any orientation. In the special case where material 40 forms a prism light guide, the octature symmetry direction must be parallel to the direction of longitudinal symmetry (i.e. the longitudinal axis) of the guide, but this is not necessary if material 40 serves another purpose, such as a cover of the type described above in relation to Figure 8.

The second vector is a "prism surface normal direction" vector 46 which is either perpendicular to or parallel to the surface normal directions of prisms 42. From the above definition of the octature property, it follows that prismatic surfaces on the opposite side of the prism light guide wall material will be inclined at 45° to the

directions just described. The prism surface normal directions must always be perpendicular to the octature symmetry direction but are otherwise unrestricted. Figures 15(a), 15(b) and 15(c) depict three different examples of 5 directions and show the resultant effect on the macroscopic structure. As mentioned earlier, all such materials are prism light guide wall material, but the direction of the prism surface normal affects the range of light rays which undergo total internal reflection in the case of light rays 10 which lie beyond the acceptance angle of prism light guide.

Figure 16 depicts a generalized shape for an outer prism light guide 48 (i.e. analogous to guide 32 of Figure 11). The prisms are not drawn explicitly as they are too small to see in this illustration, but they are described 15 below using the foregoing dual vector terminology. The cross-sectional shape of guide 48 is uniform in the plane perpendicular to a selected optical center line 50, but is arbitrary otherwise. The prisms on the prism light guide wall material forming guide 48 are characterized at any 20 point as follows:

1. the material's octature symmetry direction 44 at such point is parallel to the optical center line 50 of guide 48; and,
2. the prism surface normal direction 46 of the material's prisms is defined by a line extending from such 25 point through and perpendicular to optical center line 50.

If guide 48 is circular in cross-section, the foregoing definition yields a prism light guide like that shown in 30 Figure 1. For other shapes there will be prismatic surfaces on both the inside and the outside of the material.

Figure 17 shows a generalized cover 52 positionable within generalized guide 48. Cover 52 is made of prism light guide wall material, but is not a prism light guide. 35 The material comprising cover 52 defines a figure of revolution about the same optical center line 50 as seen in Figure 16. Thus, cover 52 is circular in all cross-sec-

- 14 -

tions perpendicular to optical center line 50. The diameter of this circular cross-section need not be constant: as depicted in Figure 17 the diameter may vary along optical center line 50, so that a wide variety of shapes are possible for cover 52. For example a spherical shell would fall within the restrictions described above. The simplest and most common example is that of a cylinder but other possibilities may be very advantageous in certain situations.

10 As previously mentioned, cover 52 is not a prism light guide. Unlike guide 48, the octature symmetry direction of the prism light guide material forming cover 52 is not constant throughout, but rather varies from position to position. At any point on cover 52, the relationship shown for exemplary point 54 (Figure 17) holds true; namely, the octature symmetry direction 56 of cover 52 at point 54 is perpendicular to the first octature symmetry direction 44 of Figure 16 and also is perpendicular to a line 58 drawn from point 54 through and perpendicular to optical center line 50. The other defining characteristic of the material forming cover 52 is that the outside prism surface normal reference is defined by line 58.

25 If cover 52 is cylindrical, the above restrictions generate a prismatic structure such as that shown in Figure 8 with prisms on one side only. But, in general, prismatic surfaces will be found on both the inside and the outside of the cover material.

30 The foregoing generalized geometrical characterization makes it possible to maintain the diffuse light guidance capability described in reference to the specific geometries of Figures 1 through 12, with substantially more design freedom. Exactly the same concepts apply; namely, insuring that the zone of possible light exitance from the cover always consists of ray directions which are incapable of being transmitted by the wall material of the prism light guide, so that they are guided. As with the specific examples described previously, it is necessary to ensure

- 15 -

that the cover has a sufficiently small diameter that this guidance effect is achieved. Also, as with the specific examples described previously, this diameter will be substantially larger than that which would be possible for a diffuse light source not contained within the cover. Again, as before, the diffuse light source will be within the cover and positioned in such a way that any light rays escaping directly from the cover rather than through it will be at angles for which their light is substantially guided by the outer light guide.

As will be apparent to those skilled in the art in the light of the foregoing disclosure, many alterations and modifications are possible in the practice of this invention without departing from the spirit or scope thereof. Accordingly, the scope of the invention is to be construed in accordance with the substance defined by the following claims.

WHAT IS CLAIMED IS:

1. A light guide containing a light source, said light guide comprising:

- 5 (a) an outer prism light guide (48) formed of prism light guide wall material, having uniform shape in cross-sections perpendicular to a first octature symmetry direction (44), and having an optical centre line (50) parallel to said first octature symmetry direction (44), wherein:
- 10 (i) inner and outer surfaces of said light guide wall material are substantially in octature with each other relative to said first octature symmetry direction (44);
- (ii) a surface normal vector (46) at any point on any internal surface of said material is either substantially parallel or substantially perpendicular to a first notional line extending from said point through and
- 15 perpendicular to said optical centre line (50);
- (b) a cover (52) positioned within said guide (48), around said light source, in cylindrical symmetry about said optical centre line (50), to intercept a substantial portion of light
- 20 emitted by said source, said cover (52) being formed of prism light guide wall material wherein:
- (i) inner and outer surfaces of said cover wall material are substantially in octature with each other at any point (54) on said cover (52) relative to a second, spatially variable octature symmetry direction (56)
- 25 tangential to a circular cross section of the cover at said point, which, at said point (54), is:
- (A) perpendicular to said first octature symmetry direction (44); and,
- 30 (B) perpendicular to a second notional line (58) extending from said point (54) on said cover

through and perpendicular to said optical centre line (50);

- 5 (ii) a surface normal vector at any point on any outer surface of said cover (52) is either substantially parallel or substantially perpendicular to said first octature symmetry direction (44); and,
- (iii) said cover (52) is confined to a region sufficiently close to said optical centre line (50) to substantially prevent propagation of light rays incident on an inside surface of said cover (52) to and through said light guide wall material.
- 10

2. A light guide as defined in claim 1, wherein said cover (52) forms a cylinder.

15

3. A light guide as defined in claim 2, wherein:

- (a) said cylinder has a length "l" and a diameter "d";
- (b) said length "l" is less than said light guide length dimension; and,
- 20 (c) each end of said cylinder extends more than 1.65 times said diameter "d" beyond said light source.

4. A light guide as defined in claim 1 or 2 or 3, wherein said light guide (48) forms a cylinder.

25

5. A light guide as defined in claim 1 or 2 or 3, wherein said light guide (48, 32) and said cover (52, 30) form partial concentric cylinders truncated by a planar metallic reflector (34) which intersects said optical centre line.

30

6. A light guide as defined in claim 1 or 2 or 3, wherein said prism light guide further comprises:
 - (a) light extraction means for controllably emitting light at selected points along said guide; and,
 - 5 (b) end reflector means for preventing light emission through either opposed end of said guide.

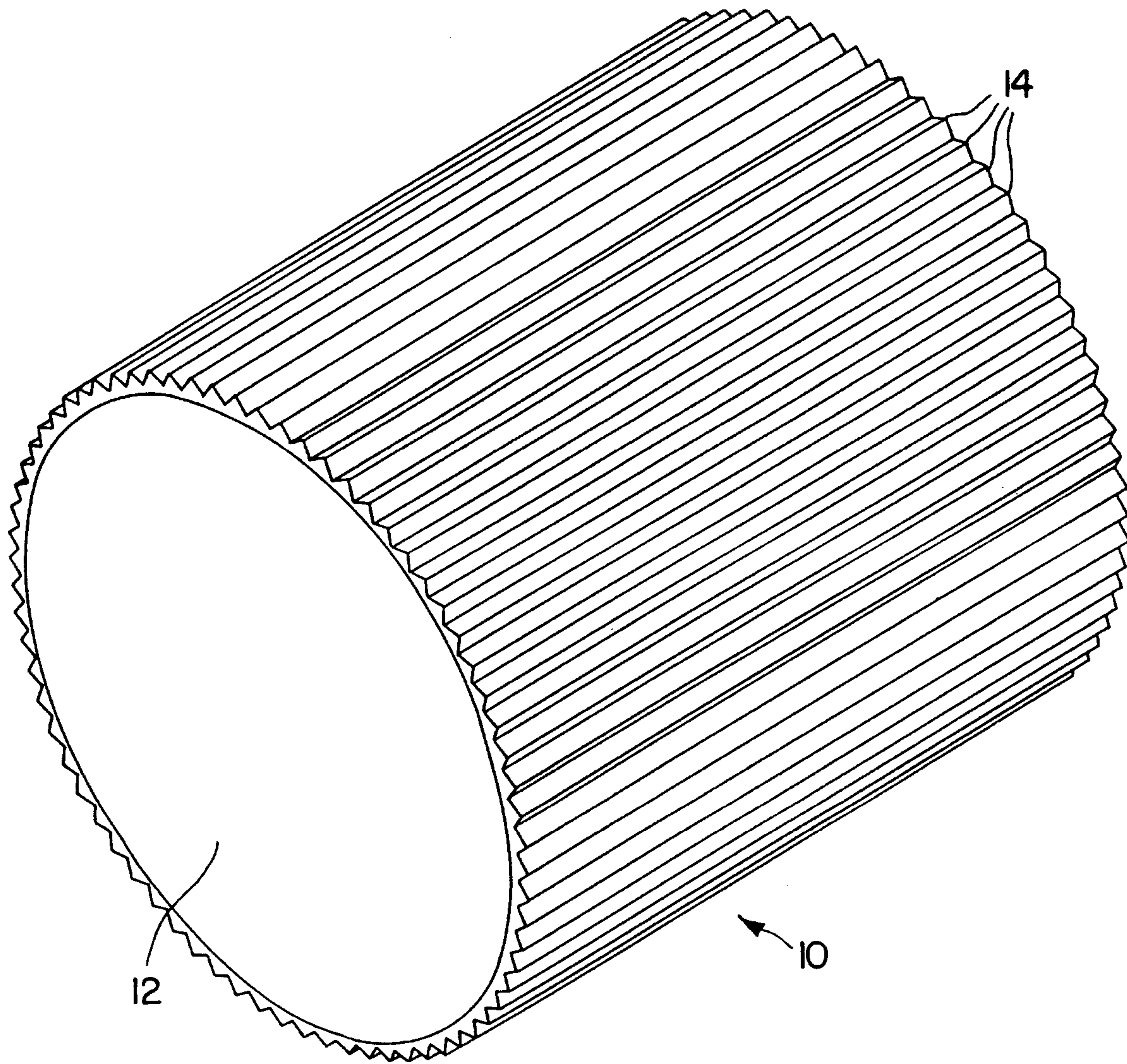

FIG. 1
PRIOR ART

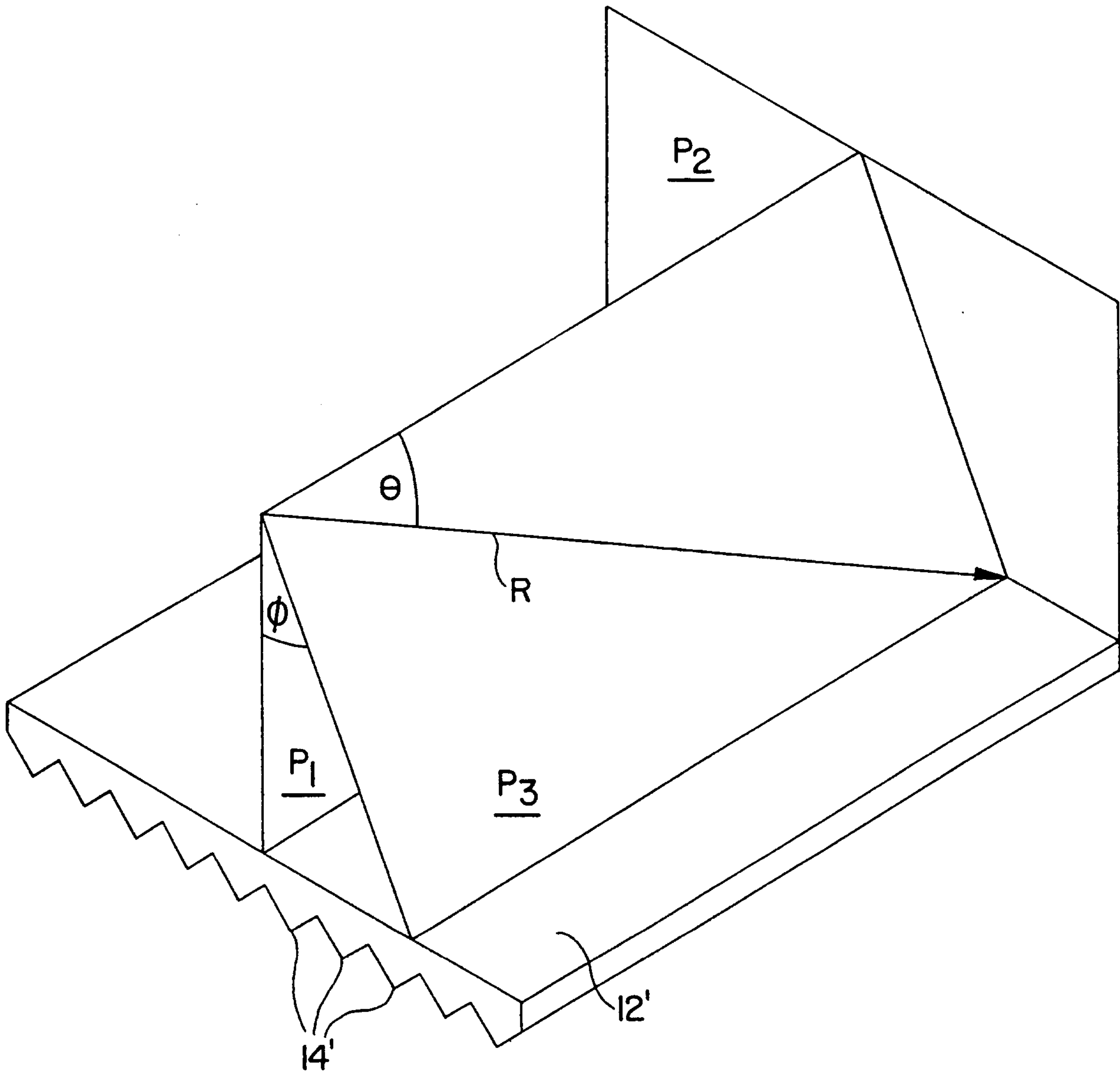

FIG. 2
PRIOR ART

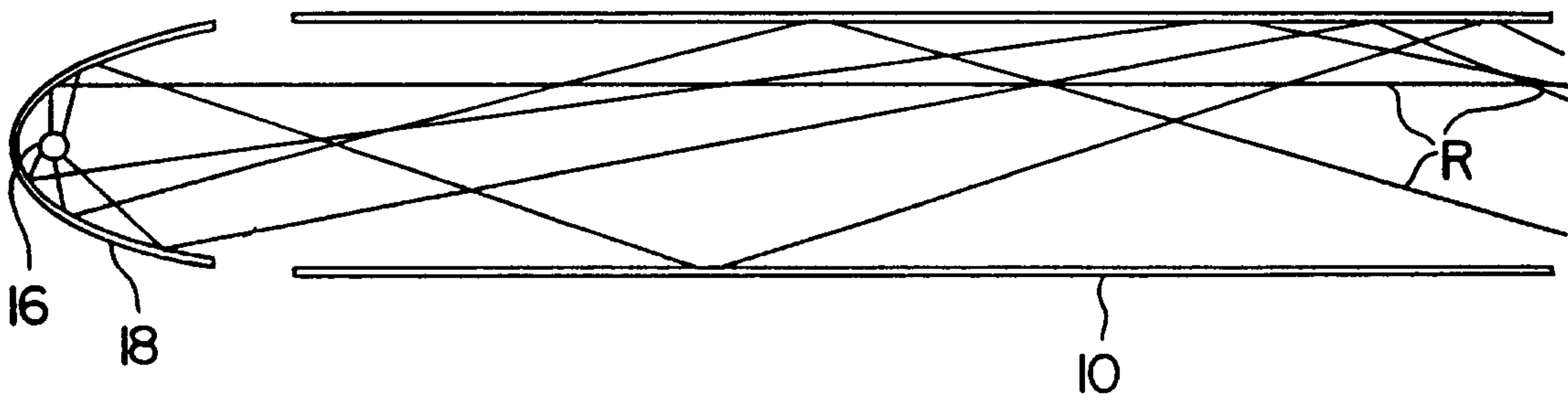

FIG. 3
PRIOR ART

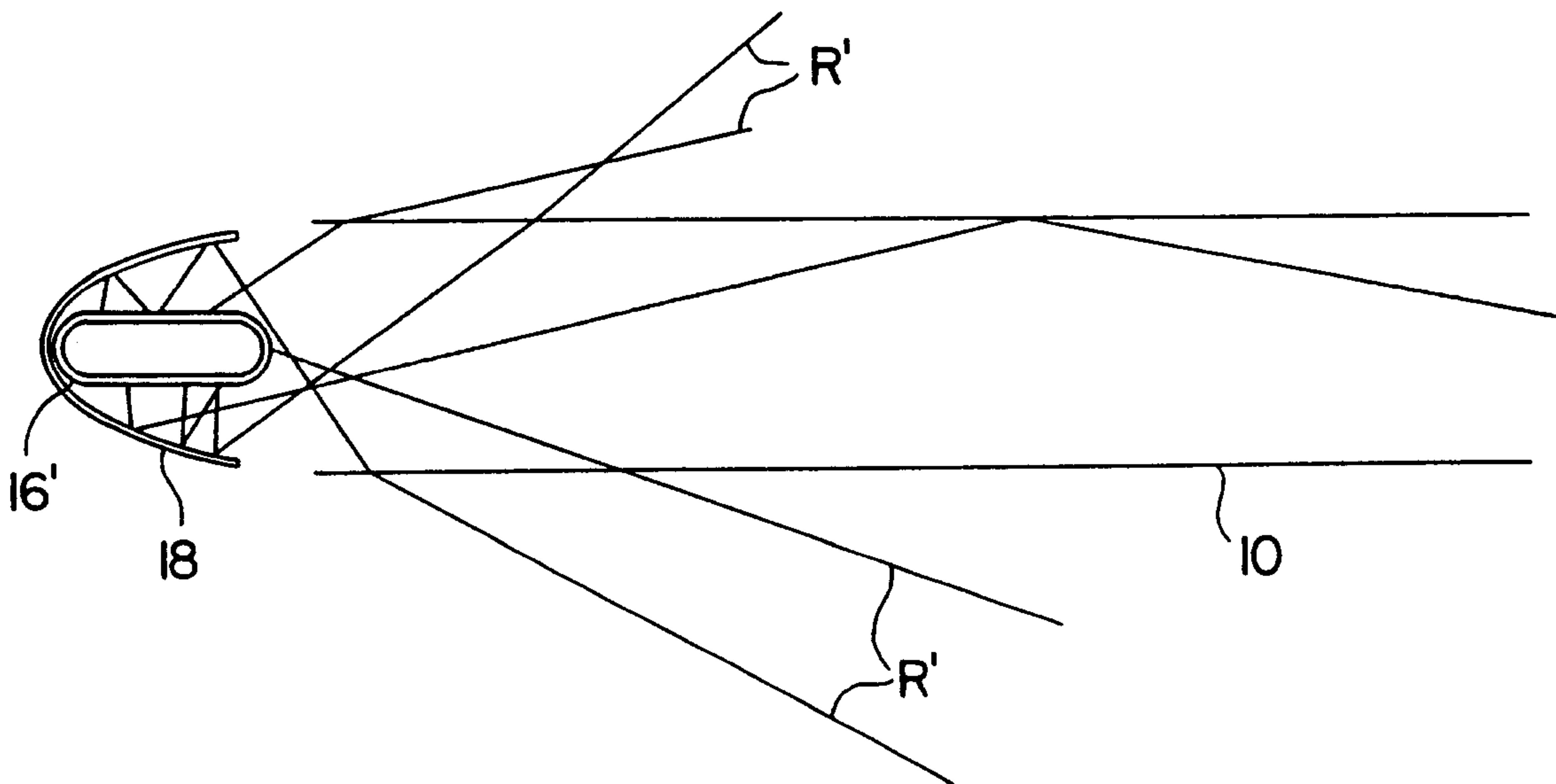

FIG. 4
PRIOR ART

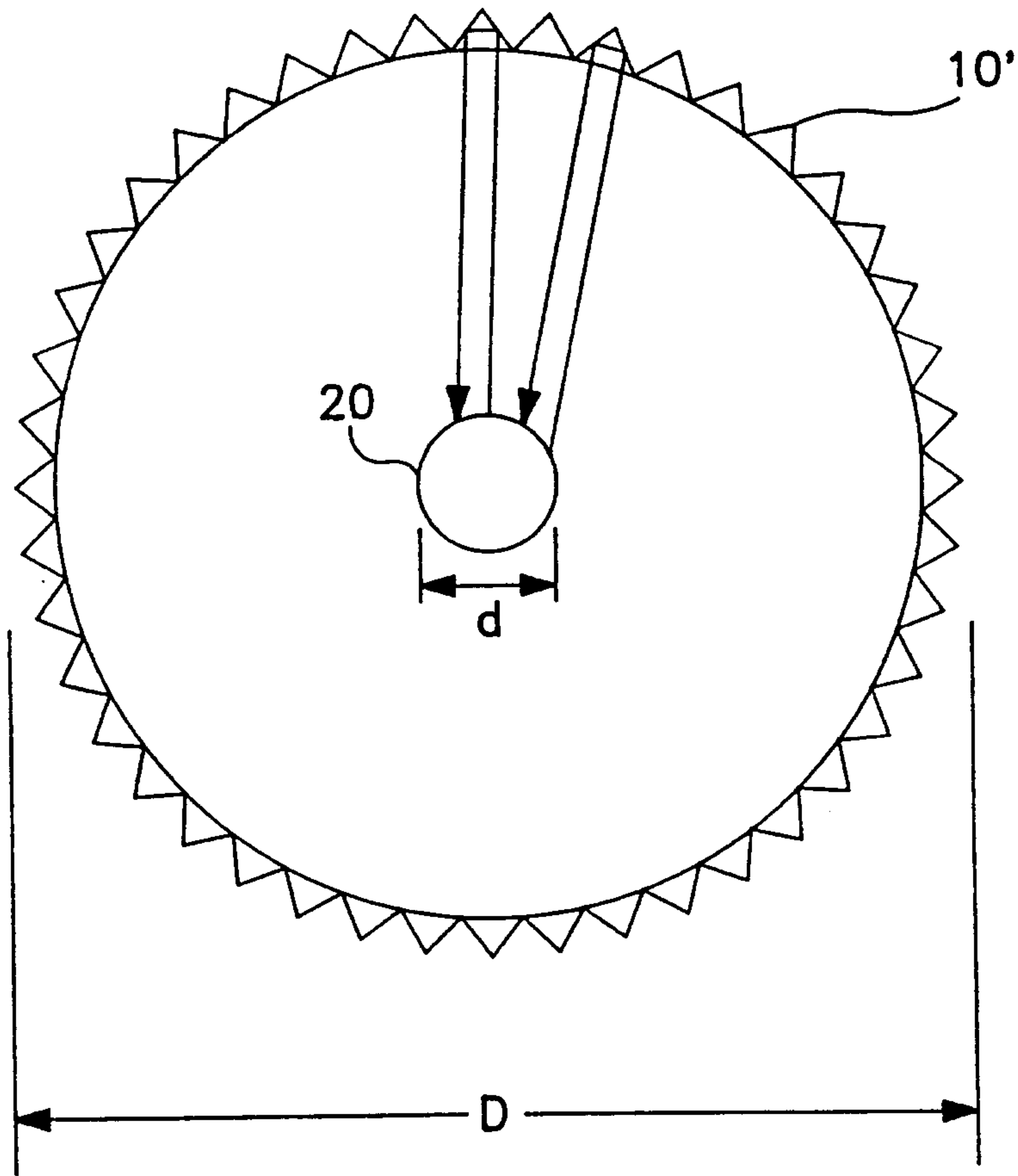

FIG. 5

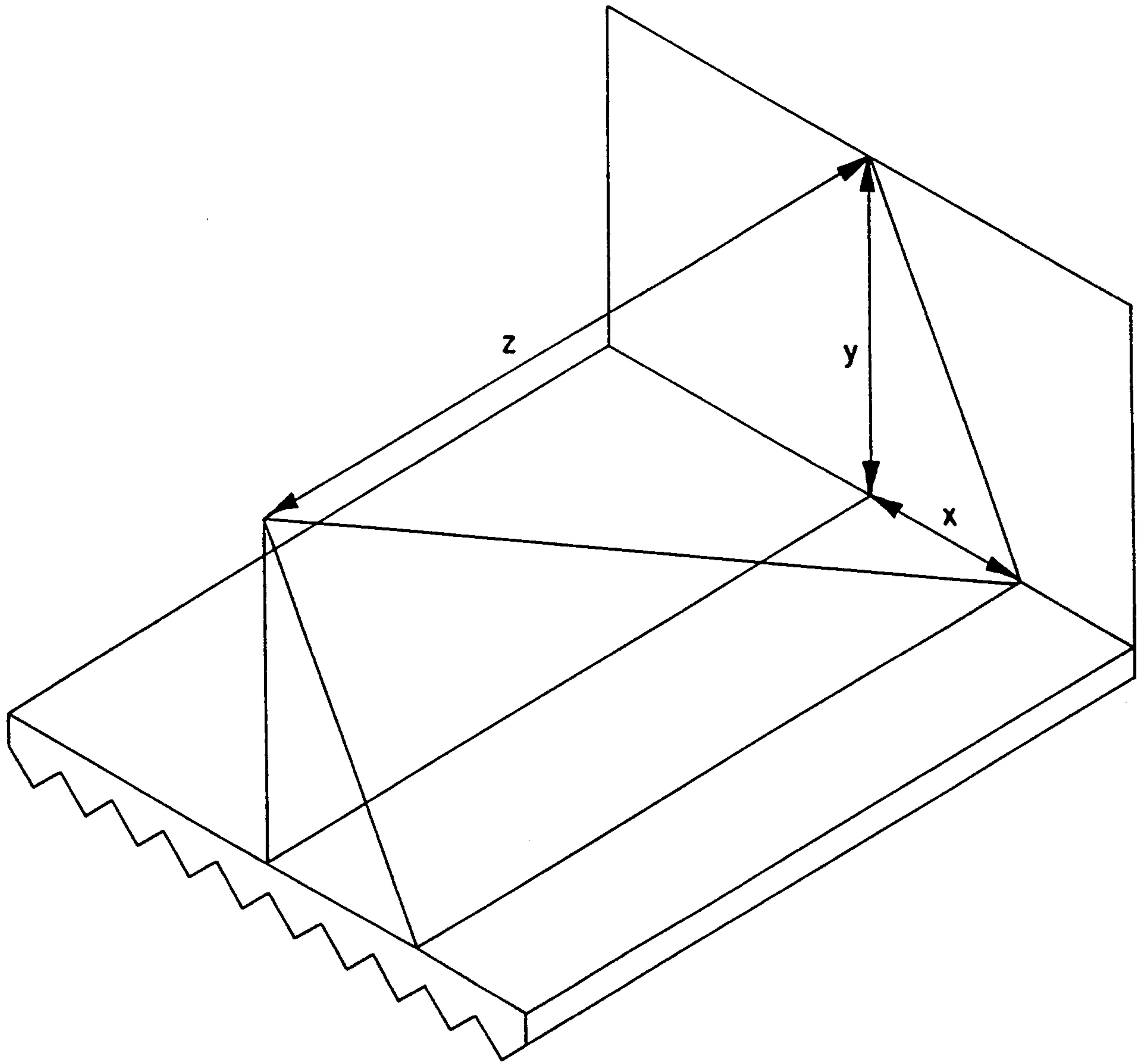

FIG. 6

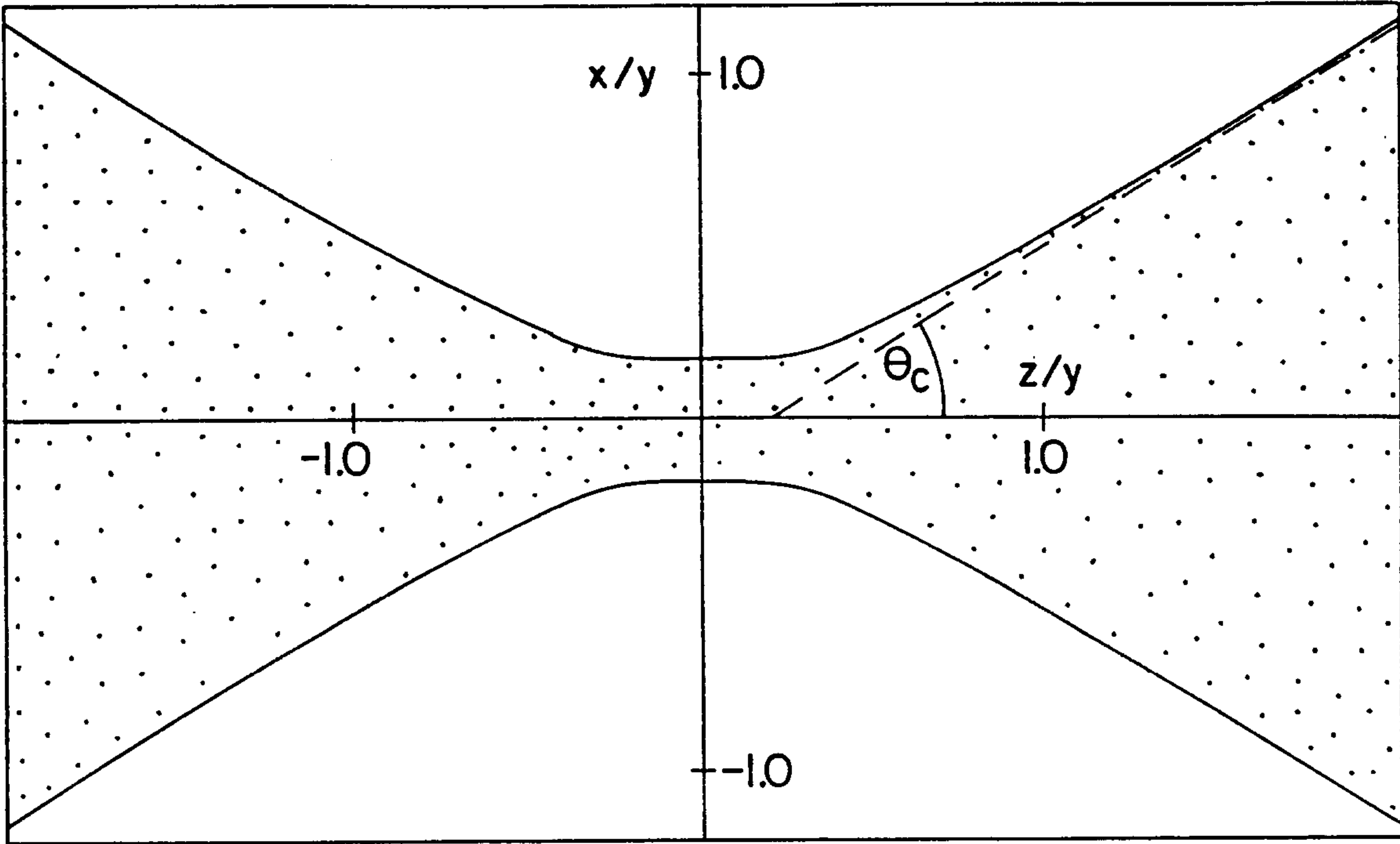

FIG. 7

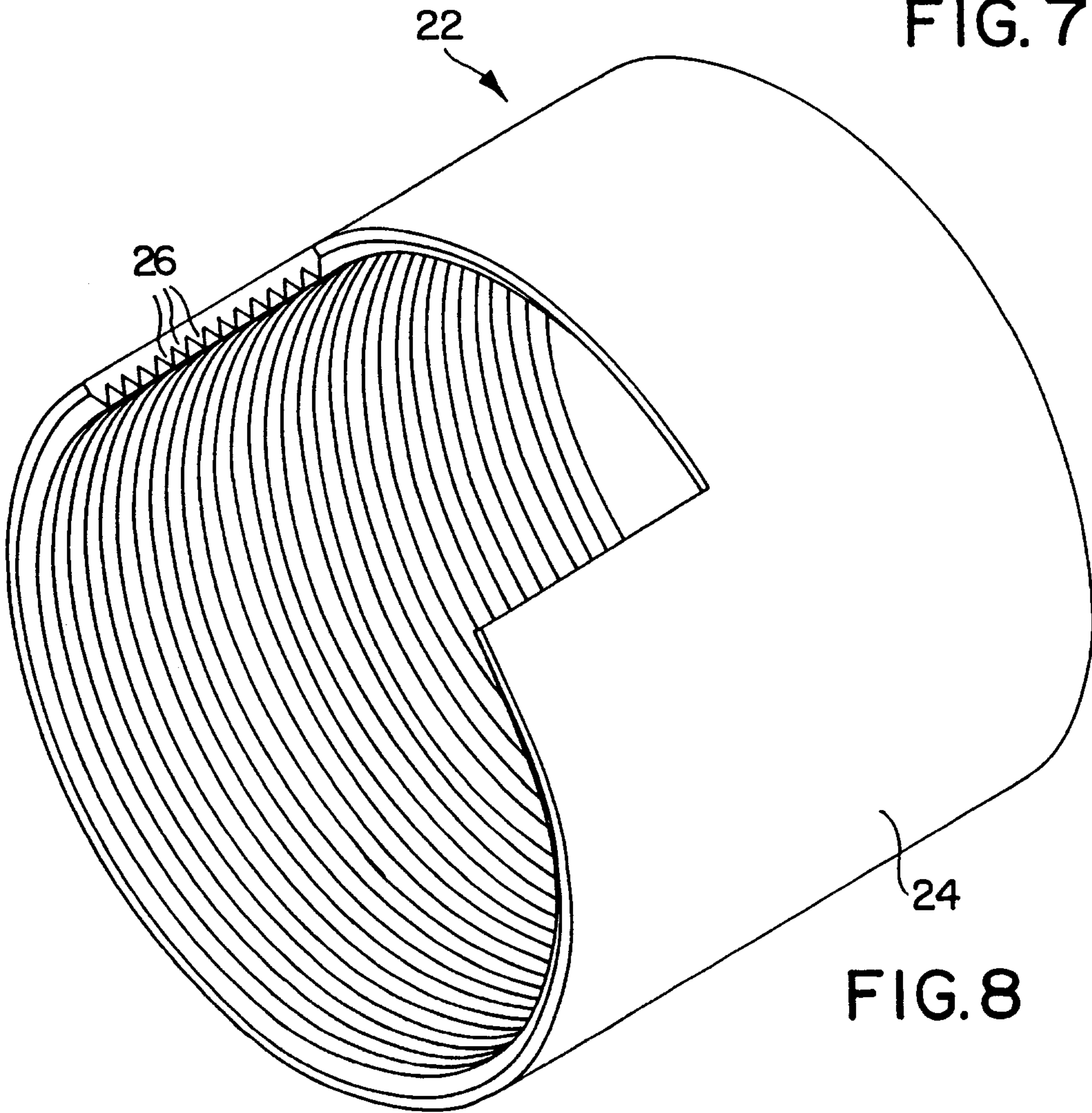

FIG. 8

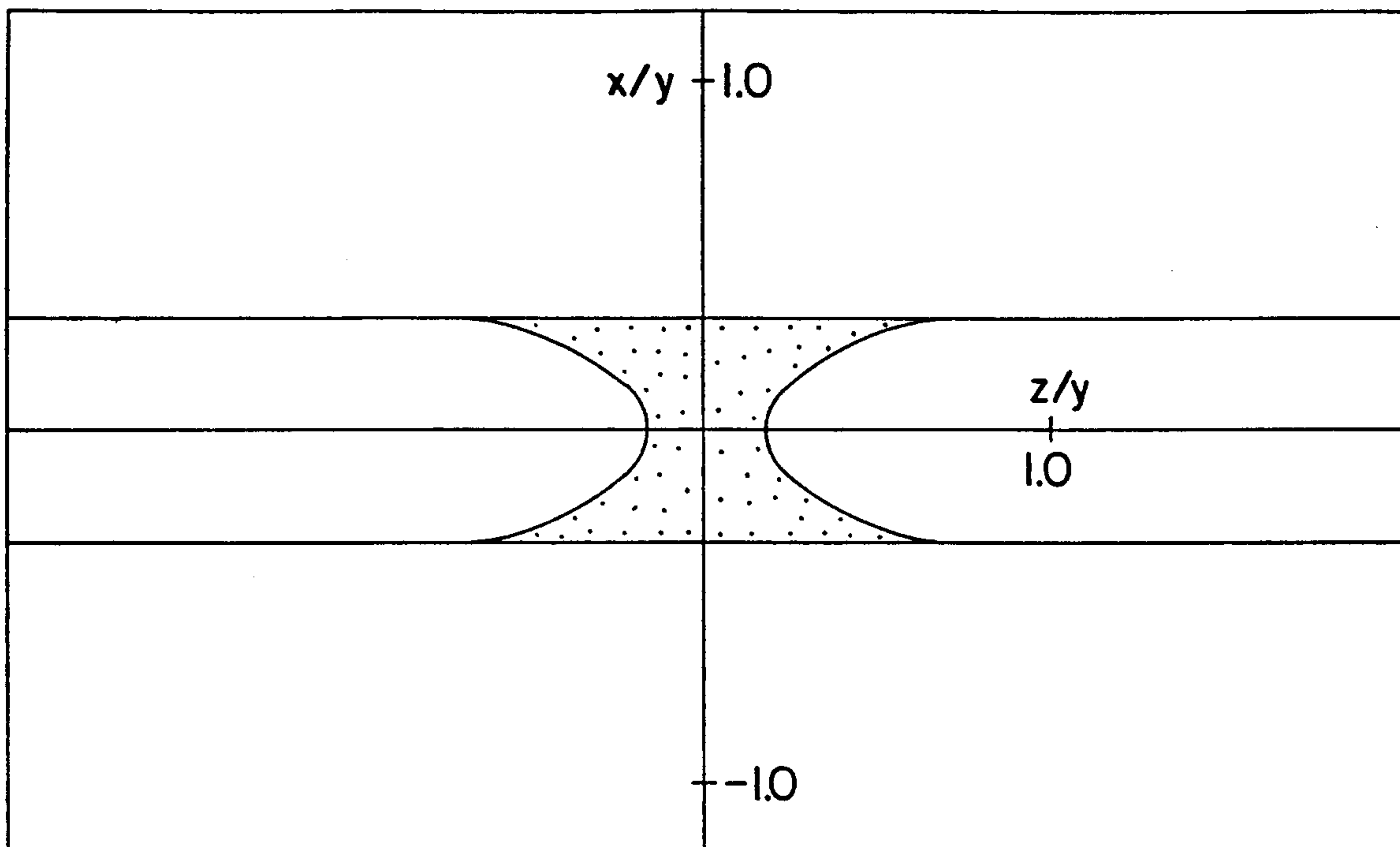

FIG. 9

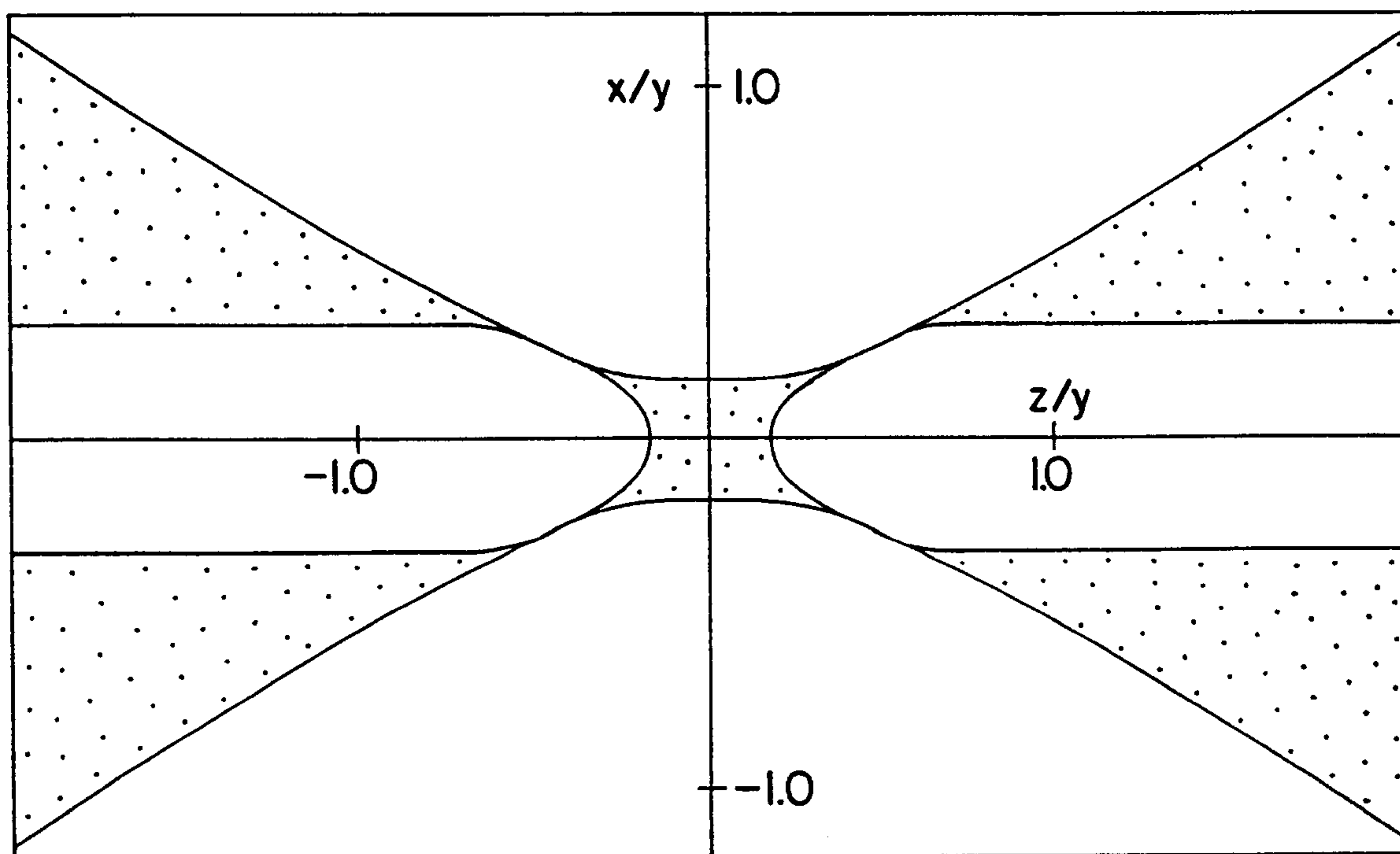

FIG. 10

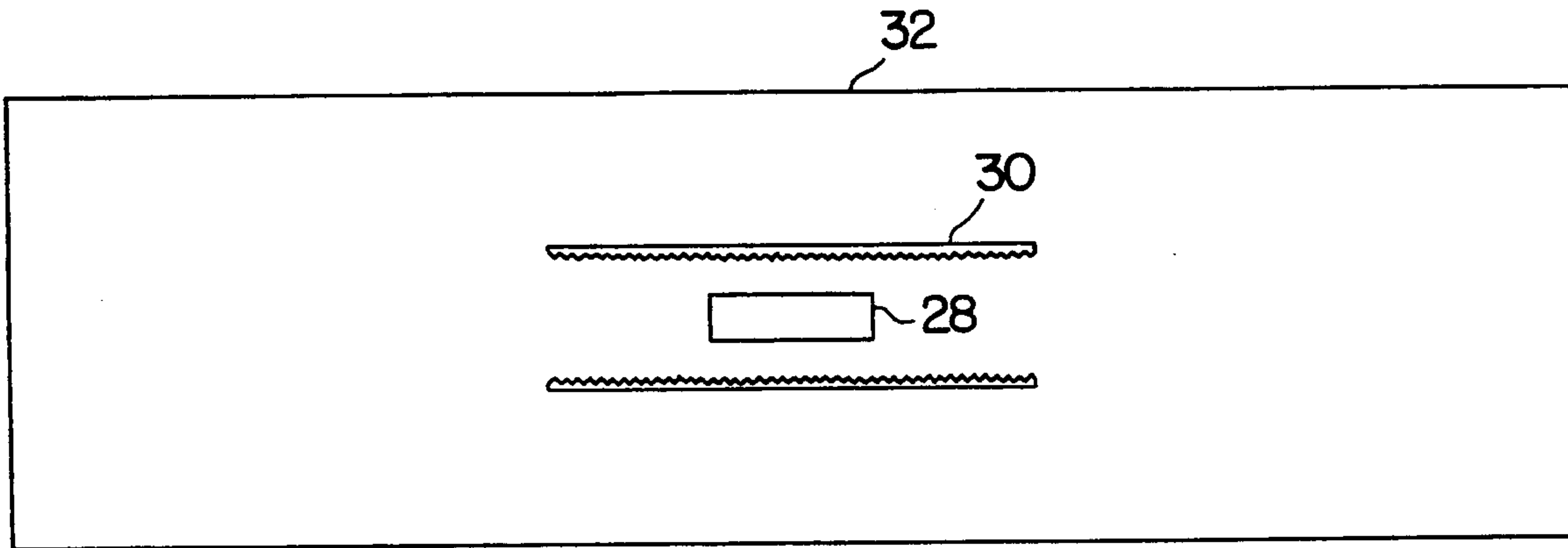

FIG. 11

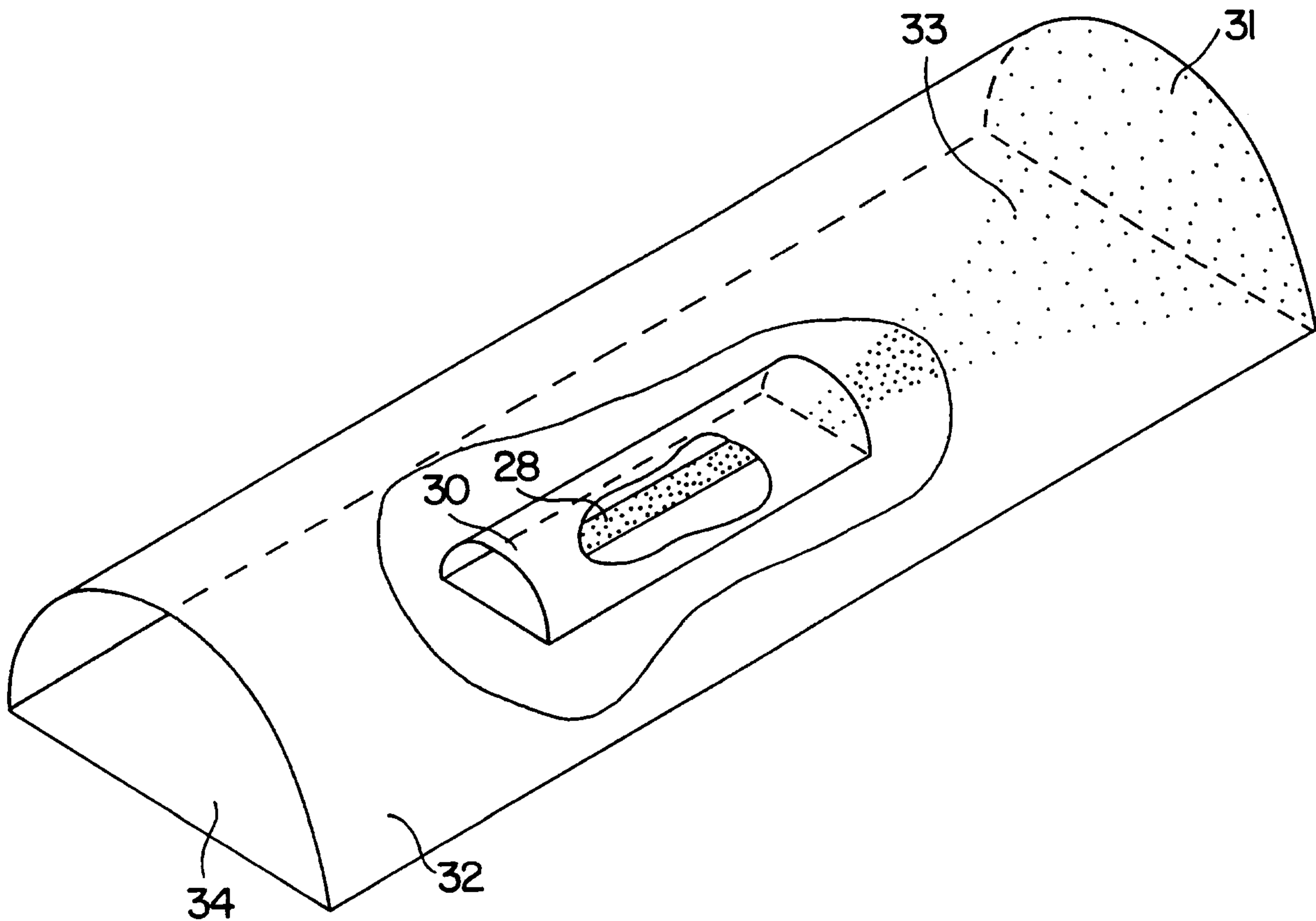

FIG. 12

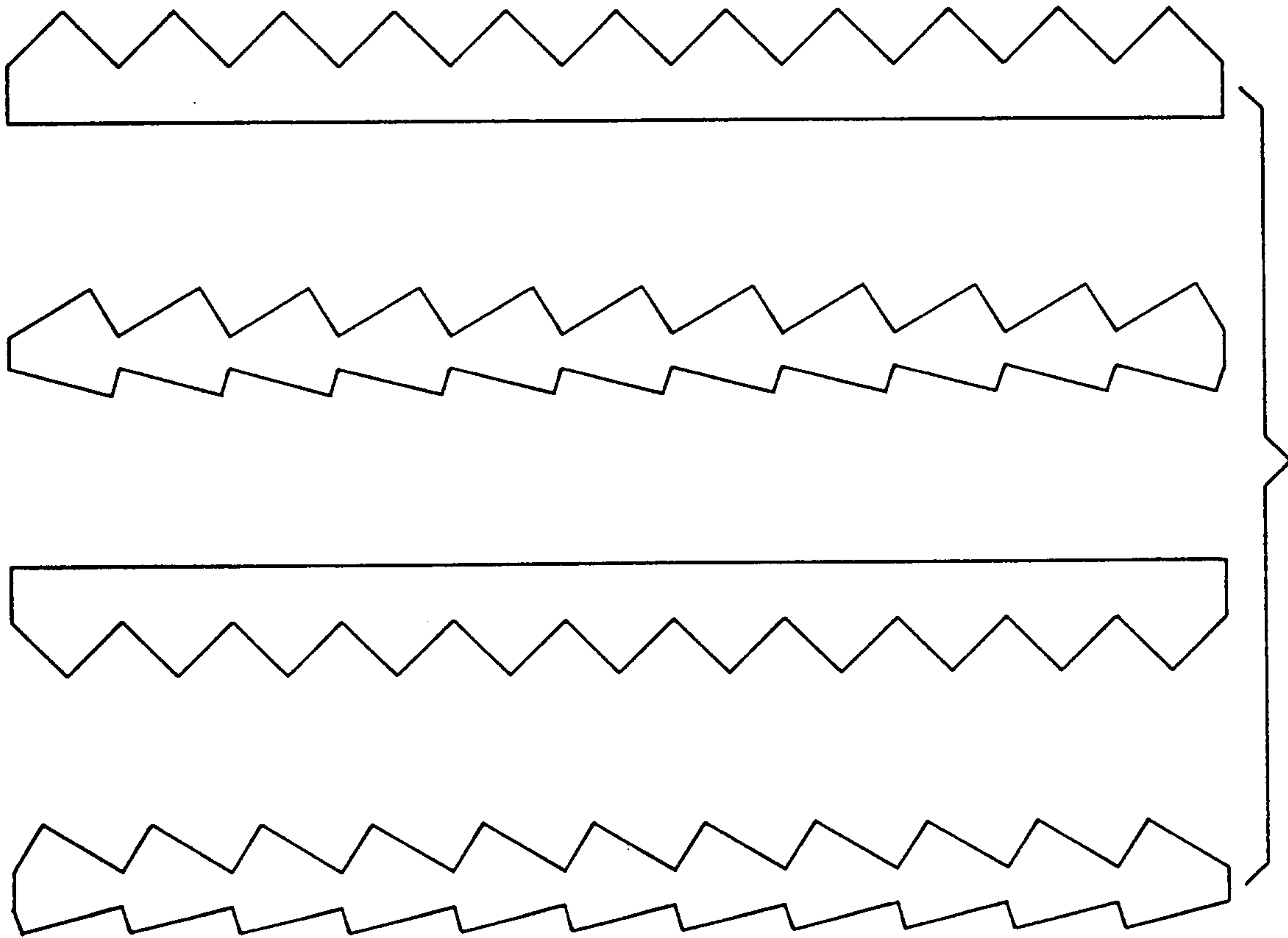

FIG. 13

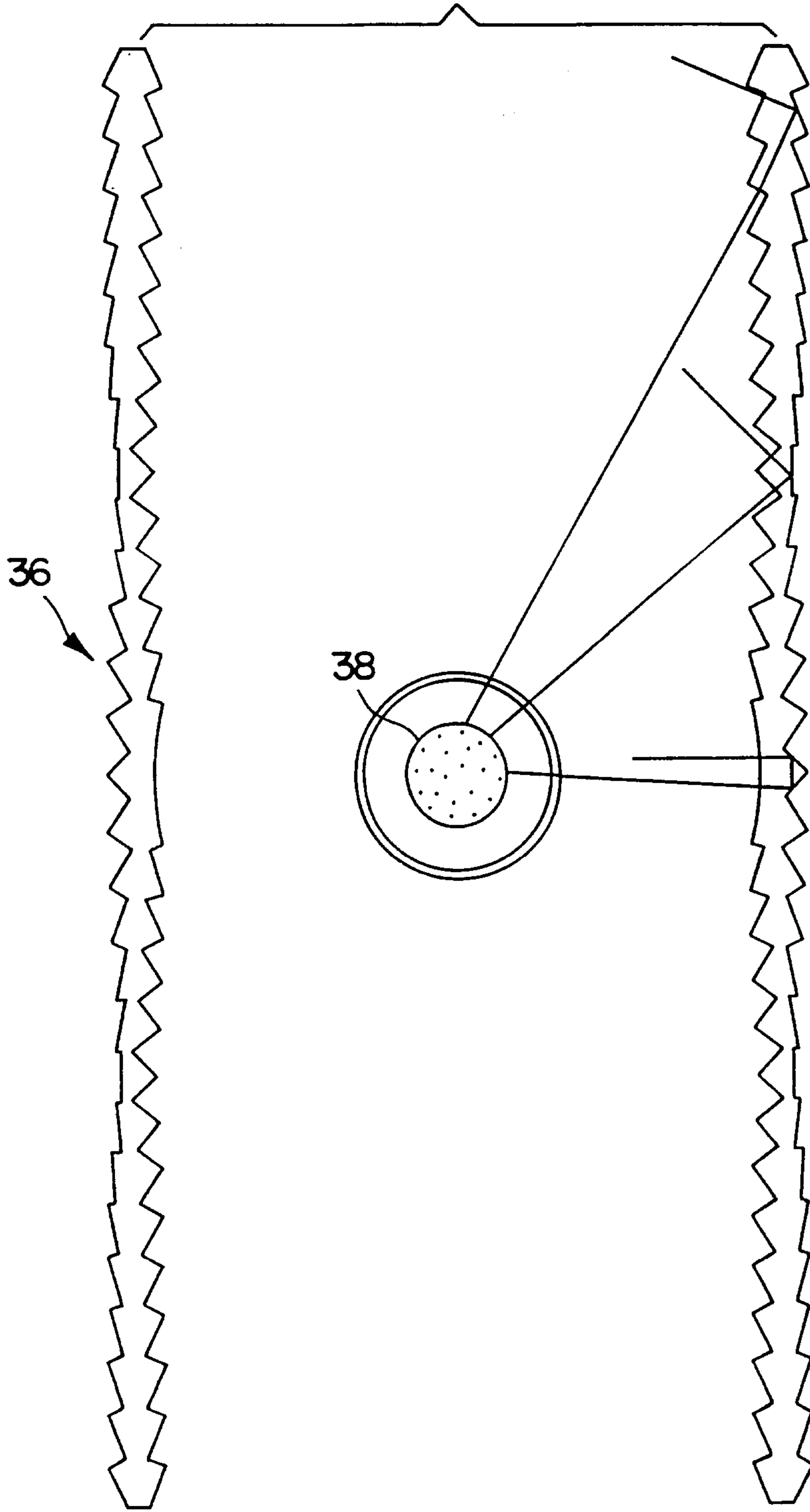

FIG. 14

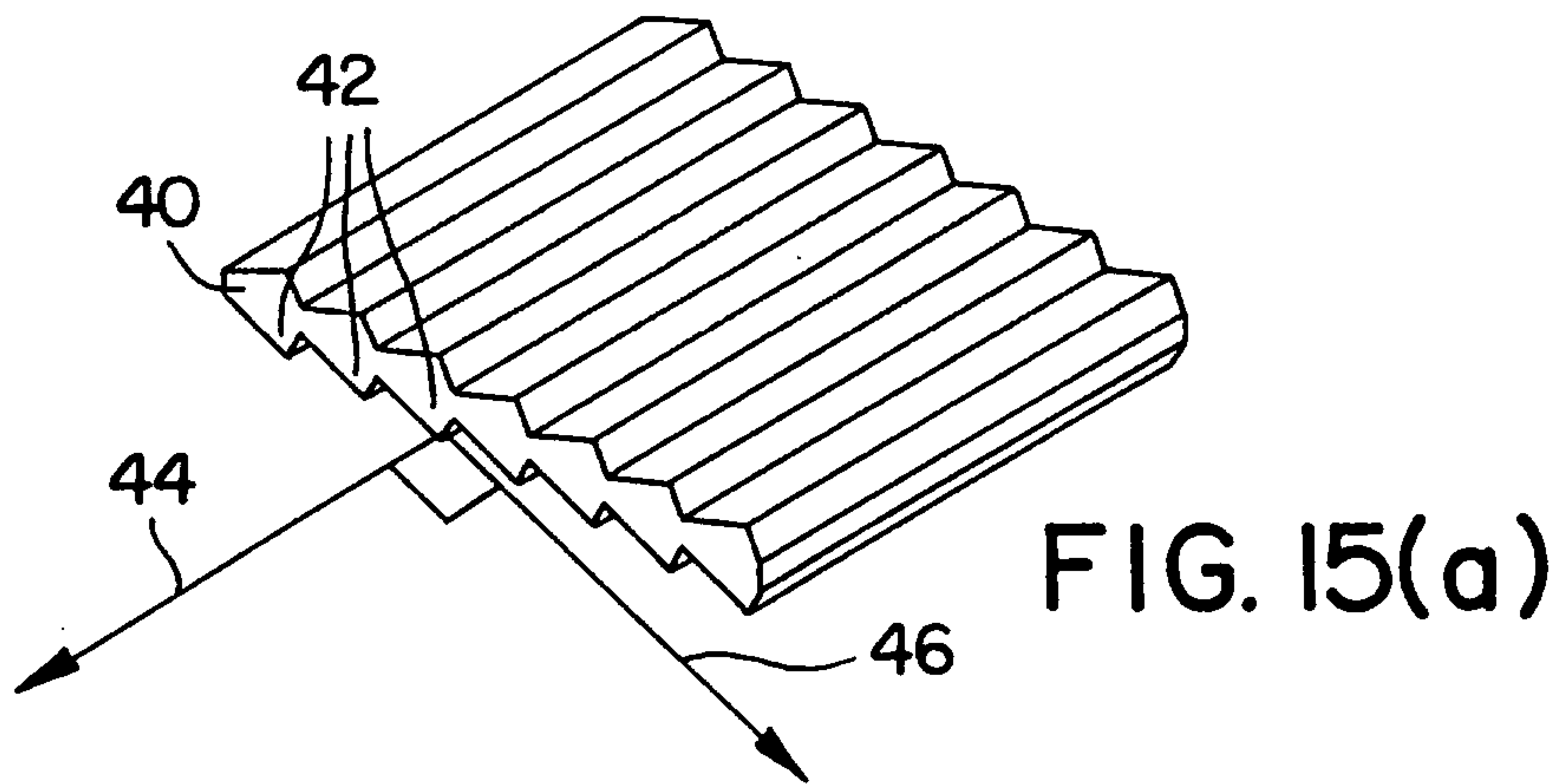

FIG. 15(a)

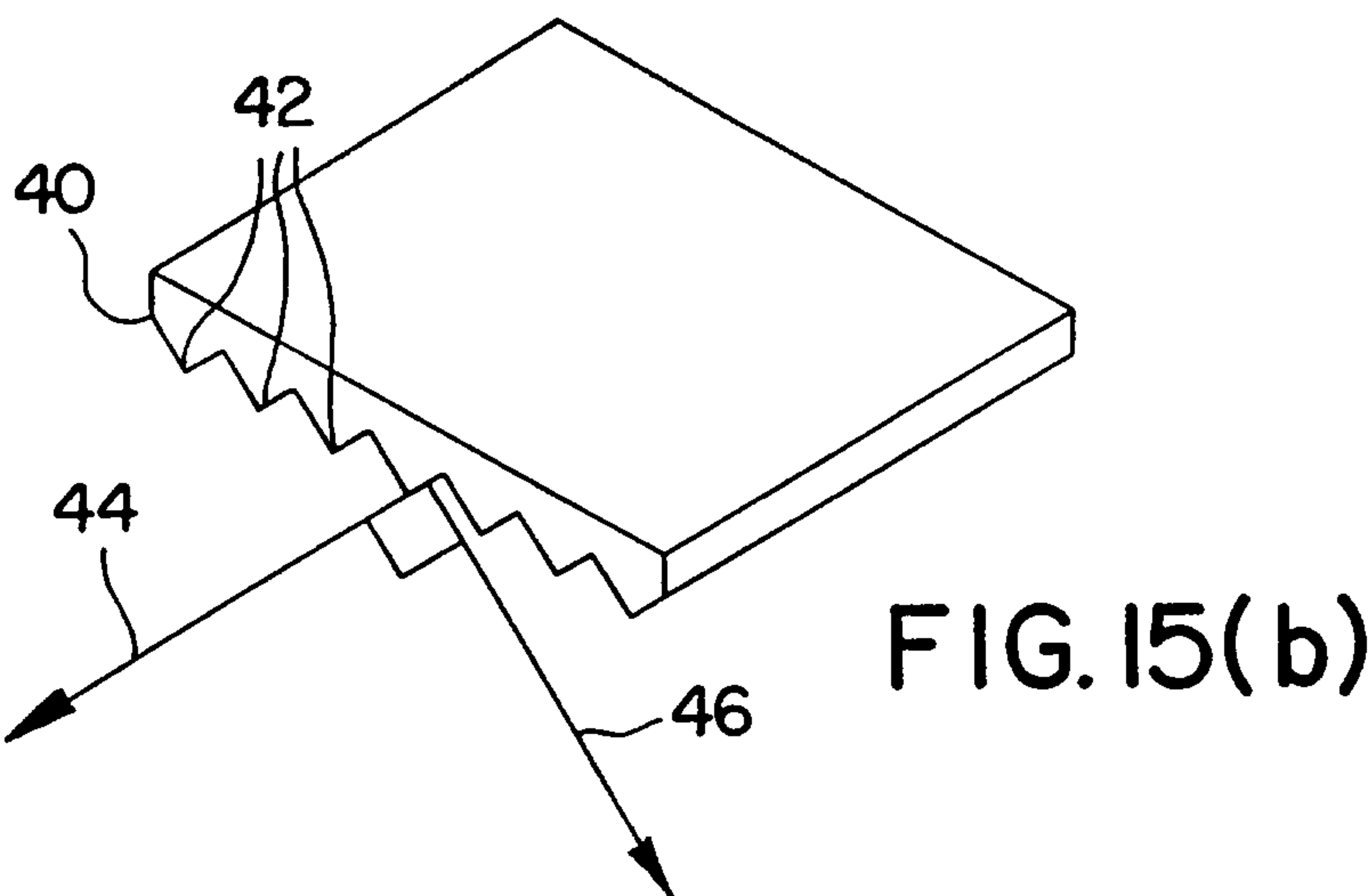

FIG. 15(b)

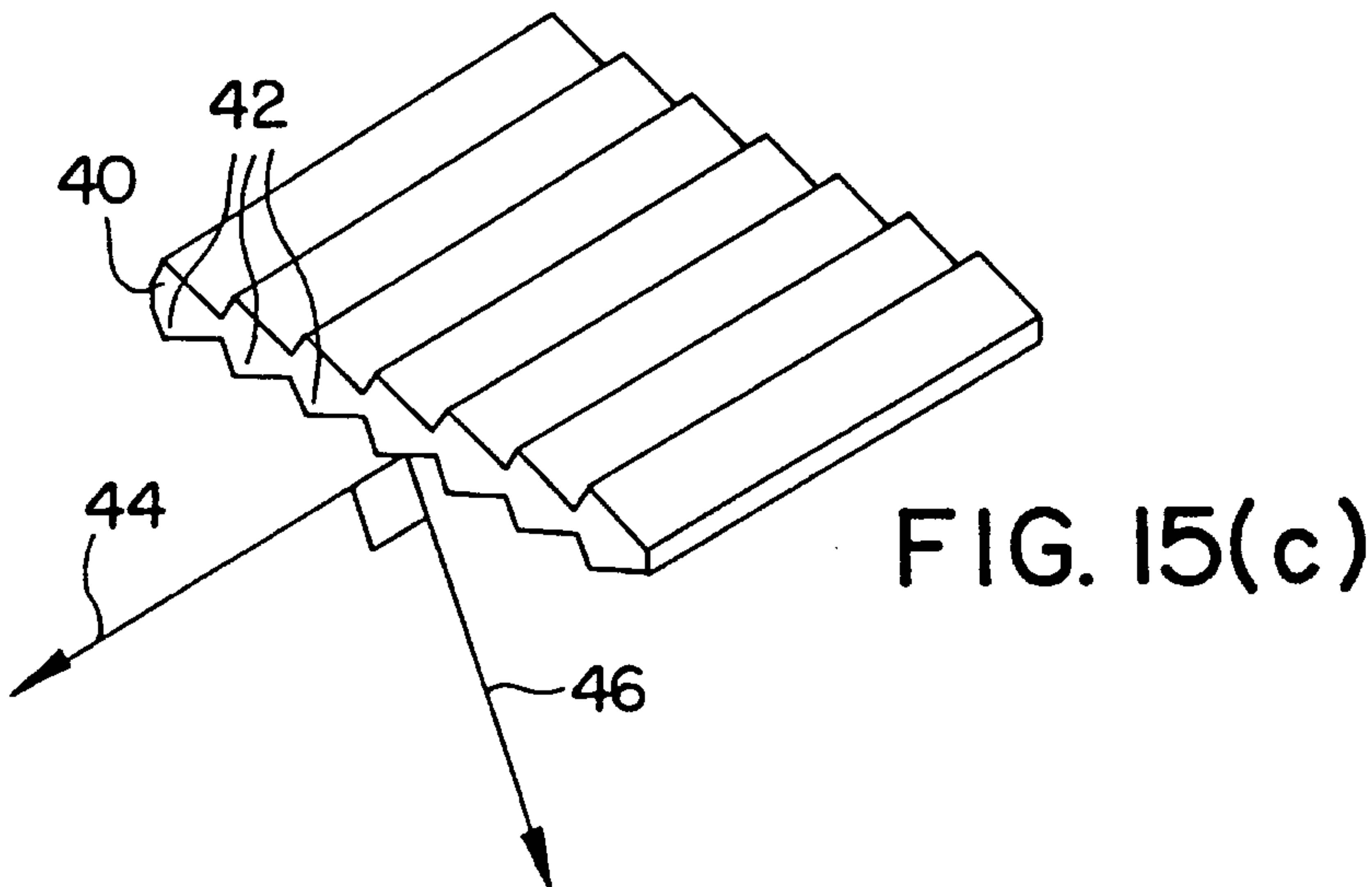

FIG. 15(c)

12/12

