

(19) World Intellectual Property Organization
International Bureau



(43) International Publication Date
12 April 2007 (12.04.2007)

PCT

(10) International Publication Number
WO 2007/041215 A2

(51) International Patent Classification:
A61B 5/00 (2006.01)

(21) International Application Number:
PCT/US2006/037850

(22) International Filing Date:
29 September 2006 (29.09.2006)

(25) Filing Language: English

(26) Publication Language: English

(30) Priority Data:
11/241,014 30 September 2005 (30.09.2005) US

(71) Applicant (for all designated States except US): **NELL-COR PURITAN BENNETT INCORPORATED**
[US/US]; 4280 Hacienda Drive, Pleasanton, CA 94588 (US).

(72) Inventor; and

(75) Inventor/Applicant (for US only): **MATLOCK, George**
[US/US]; 7755 Fairbrook Court, Pleasanton, CA 94588 (US).

(74) Agent: **SLAYDEN, Bruce, W., II**; Baker Botts L.L.P.,
1500 San Jacinto Center, 98 San Jacinto Blvd., Austin, TX
78701 (US).

(81) Designated States (unless otherwise indicated, for every kind of national protection available): AE, AG, AL, AM,

AT, AU, AZ, BA, BB, BG, BR, BW, BY, BZ, CA, CH, CN, CO, CR, CU, CZ, DE, DK, DM, DZ, EC, EE, EG, ES, FI, GB, GD, GE, GH, GM, HN, HR, HU, ID, IL, IN, IS, JP, KE, KG, KM, KN, KP, KR, KZ, LA, LC, LK, LR, LS, LT, LU, LV, LY, MA, MD, MG, MK, MN, MW, MX, MY, MZ, NA, NG, NI, NO, NZ, OM, PG, PH, PL, PT, RO, RS, RU, SC, SD, SE, SG, SK, SL, SM, SV, SY, TJ, TM, TN, TR, TT, TZ, UA, UG, US, UZ, VC, VN, ZA, ZM, ZW.

(84) Designated States (unless otherwise indicated, for every kind of regional protection available): ARIPO (BW, GH, GM, KE, LS, MW, MZ, NA, SD, SL, SZ, TZ, UG, ZM, ZW), Eurasian (AM, AZ, BY, KG, KZ, MD, RU, TJ, TM), European (AT, BE, BG, CH, CY, CZ, DE, DK, EE, ES, FI, FR, GB, GR, HU, IE, IS, IT, LT, LU, LV, MC, NL, PL, PT, RO, SE, SI, SK, TR), OAPI (BF, BJ, CF, CG, CI, CM, GA, GN, GQ, GW, ML, MR, NE, SN, TD, TG).

Declarations under Rule 4.17:

- as to applicant's entitlement to apply for and be granted a patent (Rule 4.17(ii))
- as to the applicant's entitlement to claim the priority of the earlier application (Rule 4.17(iii))

Published:

- without international search report and to be republished upon receipt of that report

For two-letter codes and other abbreviations, refer to the "Guidance Notes on Codes and Abbreviations" appearing at the beginning of each regular issue of the PCT Gazette.



WO 2007/041215 A2

(54) Title: FOLDING MEDICAL SENSOR AND TECHNIQUE FOR USING THE SAME

(57) Abstract: A sensor assembly is provided that includes a frame upon which electrical and optical components may be disposed and a covering, such as an overmold coating, provided about the frame. The frame may be moved between an open and a closed configuration, such as during the manufacture of the sensor assembly. The sensor assembly includes a retaining component configured to hold the sensor in the closed configuration when engaged. In one embodiment, the sensor may be placed on a patient's finger, toe, ear, and so forth to obtain pulse oximetry or other physiological measurements.

FOLDING MEDICAL SENSOR AND TECHNIQUE FOR USING THE SAME

BACKGROUND OF THE INVENTION

5 1. Field Of The Invention

The present invention relates generally to medical devices and, more particularly, to sensors used for sensing physiological parameters of a patient.

10 2. Description Of The Related Art

This section is intended to introduce the reader to various aspects of art that may be related to various aspects of the present invention, which are described and/or claimed below. This discussion is believed to be helpful in providing the reader with background information to facilitate a better understanding of the various aspects of the present invention. Accordingly, it should be understood that these statements are to be read in this light, and not as admissions of prior art.

15 In the field of medicine, doctors often desire to monitor certain physiological characteristics of their patients. Accordingly, a wide variety of devices have been developed for monitoring physiological characteristics. Such devices provide doctors and other healthcare personnel with the information they need to provide the best possible healthcare for their patients. As a result, such monitoring devices have become an indispensable part of modern medicine.

20 One technique for monitoring certain physiological characteristics of a patient is commonly referred to as pulse oximetry, and the devices built based upon pulse oximetry techniques are commonly referred to as pulse oximeters. Pulse oximetry may be used to measure various blood flow characteristics, such as the blood-oxygen saturation of hemoglobin in arterial blood, the volume of individual blood pulsations supplying the tissue, and/or the rate of blood pulsations corresponding to each heartbeat of a patient.

25 Pulse oximeters typically utilize a non-invasive sensor that is placed on or against a patient's tissue that is well perfused with blood, such as a patient's finger, toe, forehead or earlobe. The pulse oximeter sensor emits light and photoelectrically senses the absorption

30

and/or scattering of the light after passage through the perfused tissue. The data collected by the sensor may then be used to calculate one or more of the above physiological characteristics based upon the absorption or scattering of the light. More specifically, the emitted light is typically selected to be of one or more wavelengths that are absorbed or scattered in an amount related to the presence of oxygenated versus de-oxygenated hemoglobin in the blood. The amount of light absorbed and/or scattered may then be used to estimate the amount of the oxygen in the tissue using various algorithms.

In many instances, it may be desirable to employ, for cost and/or convenience, a pulse oximeter sensor that is reusable. One such type of pulse oximeter sensor is a clip-style sensor which is held on a patient by the force provided by a spring or other biasing mechanism. Such a clip-style sensor may then be removed by applying a countervailing force to the spring or biasing mechanism, thereby separating the ends of the sensor and allowing the sensor to be removed. In this manner, the clip-style sensor can be applied and removed many times, with the same or different patients.

Such reusable sensors, however, may be uncomfortable for the patient for various reasons. For example, the materials used in their construction may not be adequately compliant or supple or the structural features may include angles or edges. Furthermore, the reusable sensor should fit snugly enough that incidental patient motion will not dislodge or move the sensor, yet not so tight that it may interfere with pulse oximetry measurements. Such a conforming fit may be difficult to achieve over a range of patient physiologies without adjustment or excessive attention on the part of medical personnel. In addition, lack of a tight or secure fit may allow light from the environment to reach the photodetecting elements of the sensor. Such environmental light is not related to a physiological characteristic of the patient and may, therefore, introduce error into the measurements derived using data obtained with the sensor.

Reusable pulse oximeter sensors are also used repeatedly and, typically, on more than one patient. Therefore, over the life of the sensor, detritus and other bio-debris (sloughed off skin cells, dried fluids, dirt, and so forth) may accumulate on the surface of the sensor or in crevices and cavities of the sensor, after repeated uses. As a result, it may be desirable to quickly and/or routinely clean the sensor in a thorough manner. However, in sensors having a multi-part construction, as is typical in reusable pulse oximeter sensors, it

may be difficult to perform such a quick and/or routine cleaning. For example, such a thorough cleaning may require disassembly of the sensor and individual cleaning of the disassembled parts or may require careful cleaning using utensils capable of reaching into cavities or crevices of the sensor. Such cleaning is labor intensive and may be impractical
5 in a typical hospital or clinic environment.

SUMMARY

Certain aspects commensurate in scope with the originally claimed invention are set forth below. It should be understood that these aspects are presented merely to
10 provide the reader with a brief summary of certain forms of the invention might take and that these aspects are not intended to limit the scope of the invention. Indeed, the invention may encompass a variety of aspects that may not be set forth below.

There is provided a sensor assembly that includes: a frame, wherein the frame is configured to move between an open and a closed configuration; a covering provided over
15 at least part of the frame; at least one optical component disposed on the frame; and a retaining component configured to hold the frame in the closed configuration when engaged.

There is provided a sensor assembly that includes: a sensor body configured to move between an open and a closed position; an emitter disposed on the sensor body; a detector
20 disposed on the sensor body; and a retaining component configured to hold the sensor body in the closed configuration when engaged.

There is provided a sensor assembly that includes: a frame configured to move between an open and a closed position; an emitter disposed on the frame; a detector
disposed on the frame; and a covering provided over at least part of the frame to form a
25 sensor assembly.

There is provided a method of manufacturing a sensor that includes: situating an emitter and a detector on a frame; and coating the frame with a coating material to form a
sensor assembly, wherein the frame is substantially open when coated.

There is provided a method for acquiring physiological data that includes: emitting
30 two or more wavelengths of light from an emitter of a sensor assembly, wherein the sensor assembly is held in a closed configuration by one or more retaining components; detecting

transmitted or reflected light using a photodetector of the sensor assembly; and determining a physiological parameter based on the detected light.

There is provided a retaining component for use on a sensor assembly that includes: an elastic band configured to hold a sensor body in a substantially closed configuration.

5 There is provided a method of manufacturing a sensor body that includes: coating a frame with a coating material to form a sensor body, wherein the frame is substantially open when coated.

10 There is provided a sensor body that includes: a frame, wherein the frame is configured to move between an open and a closed configuration; a covering provided over at least part of the frame; and a retaining component configured to hold the frame in the closed configuration when engaged.

There is provided a sensor body that includes: a sensor body configured to move between an open and a closed position; and a retaining component configured to hold the sensor body in the closed configuration when engaged.

15 There is provided a sensor body that includes: a frame configured to move between an open and a closed position; and a covering provided over at least part of the frame to form a sensor assembly.

20 There is provided a frame of a sensor that includes: a frame configured to move between an open and a closed configuration; and a retaining component configured to hold the frame in the closed configuration when engaged.

25 There is provided a method for manufacturing a frame of a sensor that includes: forming a frame configured to move between an open and a closed configuration, wherein the frame comprises a retaining component configured to hold the frame in the closed configuration when engaged.

BRIEF DESCRIPTION OF THE DRAWINGS

Advantages of the invention may become apparent upon reading the following detailed description and upon reference to the drawings in which:

30 Fig. 1 illustrates a patient monitoring system coupled to a multi-parameter patient monitor and a sensor, in accordance with aspects of the present technique;

Fig. 2A illustrates a covered sensor in an open configuration, in accordance with aspects of the present technique;

Fig. 2B illustrates the sensor of Fig. 2A in a closed configuration;

Fig. 3 illustrates a covered sensor in a closed configuration, in accordance with aspects of the present technique;

Fig. 4A illustrates a covered sensor in an open configuration, in accordance with aspects of the present technique;

Fig. 4B illustrates the sensor of Fig. 4A in an intermediate configuration;

Fig. 5A illustrates a covered sensor in an open configuration, in accordance with aspects of the present technique; and

Fig. 5B illustrates the sensor of Fig. 5A in a closed configuration.

DETAILED DESCRIPTION OF SPECIFIC EMBODIMENTS

One or more specific embodiments of the present invention will be described below. In an effort to provide a concise description of these embodiments, not all features of an actual implementation are described in the specification. It should be appreciated that in the development of any such actual implementation, as in any engineering or design project, numerous implementation-specific decisions must be made to achieve the developers' specific goals, such as compliance with system-related and business-related constraints, which may vary from one implementation to another. Moreover, it should be appreciated that such a development effort might be complex and time consuming, but would nevertheless be a routine undertaking of design, fabrication, and manufacture for those of ordinary skill having the benefit of this disclosure.

It is desirable to provide a comfortable and conformable reusable patient sensor, such as for use in pulse oximetry or other applications utilizing spectrophotometry, that is easily cleaned and that is resistant to environmental light infiltration. In accordance with some aspects of the present technique, a reusable patient sensor is provided that is based upon a frame upon which the sensor components, such as light emitting diodes and photodetectors, may be situated. To simplify construction, the frame may be constructed or formed in an open configuration, as opposed to the closed configuration employed when the resulting sensor is in use. In embodiments where the sensor is constructed from

an open frame, a retaining or locking mechanism may be included on the sensor to hold the sensor in a closed configuration once folded or bent into the closed configuration.

Furthermore, the sensor may be covered, such as with a coating or overmold material, to provide patient comfort and a suitably conformable fit. In such embodiments, the frame may be covered in an open configuration to reduce the labor and complexity of the overmolding process. In addition, the retaining or locking mechanism may be provided as part of the frame that is covered, as part of the frame that is not covered, as part of the overmold material alone, or as a separate structure that is added combined with the covered sensor to hold the sensor in a closed configuration when in use.

Prior to discussing such exemplary sensors in detail, it should be appreciated that such sensors may be designed for use with a typical patient monitoring system. For example, referring now to Fig. 1, a sensor 10 according to the present invention may be used in conjunction with a patient monitor 12. In the depicted embodiment, a cable 14 connects the sensor 10 to the patient monitor 12. As will be appreciated by those of ordinary skill in the art, the sensor 10 and/or the cable 14 may include or incorporate one or more integrated circuit devices or electrical devices, such as a memory, processor chip, or resistor, that may facilitate or enhance communication between the sensor 10 and the patient monitor 12. Likewise the cable 14 may be an adaptor cable, with or without an integrated circuit or electrical device, for facilitating communication between the sensor 10 and various types of monitors, including older or newer versions of the patient monitor 12 or other physiological monitors. In other embodiments, the sensor 10 and the patient monitor 12 may communicate via wireless means, such as using radio, infrared, or optical signals. In such embodiments, a transmission device (not shown) may be connected to the sensor 10 to facilitate wireless transmission between the sensor 10 and the patient monitor 12. As will be appreciated by those of ordinary skill in the art, the cable 14 (or corresponding wireless transmissions) are typically used to transmit control or timing signals from the monitor 12 to the sensor 10 and/or to transmit acquired data from the sensor 10 to the monitor 12. In some embodiments, however, the cable 14 may be an optical fiber that allows optical signals to be conducted between the monitor 12 and the sensor 10.

In one embodiment, the patient monitor 12 may be a suitable pulse oximeter, such as those available from Nellcor Puritan Bennett Inc. In other embodiments, the patient monitor 12 may be a monitor suitable for measuring tissue water fractions, or other body fluid related metrics, using spectrophotometric or other techniques. Furthermore, the monitor 12 may be a multi-purpose monitor suitable for performing pulse oximetry and measurement of tissue water fraction, or other combinations of physiological and/or biochemical monitoring processes, using data acquired via the sensor 10. Furthermore, to upgrade conventional monitoring functions provided by the monitor 12 to provide additional functions, the patient monitor 12 may be coupled to a multi-parameter patient monitor 16 via a cable 18 connected to a sensor input port and/or via a cable 20 connected to a digital communication port.

The sensor 10, in the example depicted in Fig. 1, is a reusable sensor that is covered to provide a unitary or enclosed assembly. The sensor 10 includes an emitter 22 and a detector 24 which may be of any suitable type. For example, the emitter 22 may be one or more light emitting diodes adapted to transmit one or more wavelengths of light, such as in the red to infrared range, and the detector 24 may be a photodetector, such as a silicon photodiode package, selected to receive light in the range emitted from the emitter 22. In the depicted embodiment, the sensor 10 is coupled to a cable 14 that is responsible for transmitting electrical and/or optical signals to and from the emitter 22 and detector 24 of the sensor 10. The cable 14 may be permanently coupled to the sensor 10, or it may be removably coupled to the sensor 10 -- the latter alternative being more useful and cost efficient in situations where the sensor 10 is disposable.

The sensor 10 described above is generally configured for use as a "transmission type" sensor for use in spectrophotometric applications, though in some embodiments it may instead be configured for use as a "reflectance type sensor." Transmission type sensors include an emitter and detector that are typically placed on opposing sides of the sensor site. If the sensor site is a fingertip, for example, the sensor 10 is positioned over the patient's fingertip such that the emitter and detector lie on either side of the patient's nail bed. For example, the sensor 10 is positioned so that the emitter is located on the patient's fingernail and the detector is located opposite the emitter on the patient's finger pad. During operation, the emitter shines one or more wavelengths of light through the

patient's fingertip, or other tissue, and the light received by the detector is processed to determine various physiological characteristics of the patient.

5 Reflectance type sensors generally operate under the same general principles as transmittance type sensors. However, reflectance type sensors include an emitter and detector that are typically placed on the same side of the sensor site. For example, a reflectance type sensor may be placed on a patient's fingertip such that the emitter and detector are positioned side-by-side. Reflectance type sensors detect light photons that are scattered back to the detector.

10 For pulse oximetry applications using either transmission or reflectance type sensors the oxygen saturation of the patient's arterial blood may be determined using two or more wavelengths of light, most commonly red and near infrared wavelengths. Similarly, in other applications a tissue water fraction (or other body fluid related metric) or a concentration of one or more biochemical components in an aqueous environment may be measured using two or more wavelengths of light, most commonly near infrared
15 wavelengths between about 1,000 nm to about 2,500 nm. It should be understood that, as used herein, the term "light" may refer to one or more of infrared, visible, ultraviolet, or even X-ray electromagnetic radiation, and may also include any wavelength within the infrared, visible, ultraviolet, or X-ray spectra.

20 Pulse oximetry and other spectrophotometric sensors, whether transmission-type or reflectance-type, are typically placed on a patient in a location conducive to measurement of the desired physiological parameters. For example, pulse oximetry sensors are typically placed on a patient in a location that is normally perfused with arterial blood to facilitate measurement of the desired blood characteristics, such as arterial oxygen saturation measurement (SaO_2). Common pulse oximetry sensor sites
25 include a patient's fingertips, toes, forehead, or earlobes. Regardless of the placement of the sensor 10, the reliability of the pulse oximetry measurement is related to the accurate detection of transmitted light that has passed through the perfused tissue and has not been inappropriately supplemented by outside light sources or modulated by subdermal anatomic structures. Such inappropriate supplementation and/or modulation of the light
30 transmitted by the sensor can cause variability in the resulting pulse oximetry measurements.

As noted above, the sensor 10 discussed herein may be configured for either transmission or reflectance type sensing. For simplicity, the exemplary embodiment of the sensor 10 described herein is adapted for use as a transmission-type sensor. As will be appreciated by those of ordinary skill in the art, however, such discussion is merely exemplary and is not intended to limit the scope of the present technique.

Referring now to Figs. 2A and 2B, a first embodiment of the sensor 10 is depicted which includes a frame 50 covered with a covering material 52 in both an open and a closed configuration respectively. The frame 50 houses an emitter 22 and detector 24 within respective optical component housings. In the depicted embodiment, the emitter 22 and detector 24 are not covered by the covering material 52 and/or optically communicate through respective windows 54 that are substantially transparent to the wavelengths of interest and that are provided in the covering material 52.

In the depicted embodiment, the emitter 22 and detector 24 are provided substantially flush with the patient facing surfaces of the sensor 10, as may be suitable for pulse oximetry applications. For other physiological monitoring applications, such as applications measuring tissue water fraction or other body fluid related metrics, other configurations may be desirable. For example, in such fluid measurement applications it may be desirable to provide one or both of the emitter 22 and detector 24 recessed relative to the patient facing surfaces of the sensor 10. Such modifications may be accomplished by proper configuration or design of a mold or die used in overmolding the frame 50, as discussed below, and/or by proper design of the respective emitter housing and/or detector housing of the frame 50.

The frame 50 may be solid or skeletal (i.e., a framework of spaced apart beams and struts) depending on the rigidity and solidity desired of the frame 50. In addition the frame 50 may include different structures or regions composed of different materials or which have different physical properties, such as rigidity, elasticity, and so forth. The frame 50 generally defines the shape of the sensor 10 when coated, though, in some embodiments, portions of the sensor 10 may be formed from the covering material 52 without corresponding underlying frame structures. Alternatively, in other embodiments, portions of the frame 50 may not be covered and may form part of the exposed surface of the sensor 10. Indeed, though the sensor 10 is depicted in an exemplary covered

embodiment, in other embodiments, the frame 50 may not be covered but may instead primarily constitute the sensor body.

In certain embodiments, the frame 50 may be constructed, in whole or in part, from polymeric materials, such as thermoplastics, capable of providing a suitable rigidity or semi-rigidity for the different portions of the frame 50. Examples of such suitable materials include polyurethane, polypropylene and nylon, though other polymeric materials may also be suitable. In other embodiments, the frame 50 is constructed, in whole or in part, from other suitably rigid or semi-rigid materials, such as stainless steel, aluminum, magnesium, graphite, fiberglass, or other metals, alloys, or compositions that are sufficiently ductile and/or strong. For example, metals, alloys, or compositions that are suitable for diecasting, sintering, lost wax casting, stamping and forming, and other metal or composition fabrication processes may be used to construct the frame 50.

In addition, the frame 50 may be constructed as an integral structure or as a composite structure. For example, in one embodiment, the frame 50 may be constructed as a single piece from a single material or from different materials. Alternatively, the frame 50 may be constructed or assembled from two or more parts that are separately formed. In such embodiments, the different parts may be formed from the same or different materials. For example, in implementations where different parts are formed from different materials, each part may be constructed from a material having suitable mechanical and/or chemical properties for that part. The different parts may then be joined or fitted together to form the frame 50.

In addition, the frame 50 may be molded, formed, or constructed in a different configuration than the final sensor configuration or may be adjustable to various configurations. For example, the frame 50 for use in the sensor 10 may be initially formed in a generally open configuration or may be adjustable to such an open configuration. In such an embodiment, the frame 50 may be formed or adjusted to be in an open configuration such that the included angle (i.e., the angle formed by the top portion 56 and bottom portion 58 of the frame 50 pivoting about hinge region 60) is between about 5° to about 280°. In one embodiment, as will be appreciated by those of ordinary skill in the art, the open configuration may be a substantially flat configuration,

i.e., a configuration having an included angle of approximately 180° , as depicted in Fig. 2A.

In forming or adjusting the frame 50 in an open configuration, an included angle may be selected which facilitates subsequent manipulation and use of the frame 50. The included angle of the frame 50 may be chosen to facilitate or ease such tasks as inserting the emitter 22 and/or detector 24 within their respective housings, connecting signal transmission structures (such as flex circuitry) to the emitter 22 and/or detector 24, and/or covering the frame 50, and any attached components, with a covering material 52, such as an overmold material. During some or all of these different processes, the included angle of the frame 50 may be adjusted to facilitate the ongoing process. For example, the frame 50 may be provided in a flat configuration, i.e., 180° included angle, during the installation of optical components and conductive circuitry but may be adjusted to another included angle, such as 120° , for overmolding, or vice versa. The sensor 10, and therefore the frame 50, may be bent from the open configuration into a relatively closed configuration, as depicted in Fig. 2B, for subsequent use on a patient.

For example, in one embodiment, the frame 50 is overmolded in a relatively flat configuration to simplify the overmolding process, resulting in a sensor 10 as depicted in Fig. 2A. In one implementation, the covering material 52 is a thermoplastic elastomer or other conformable coating or material. In such embodiments, the thermoplastic elastomer may include compositions such as thermoplastic polyolefins, thermoplastic vulcanizate alloys, silicone, thermoplastic polyurethane, and so forth. As will be appreciated by those of ordinary skill in the art, the overmolding composition may vary, depending on the varying degrees of conformability, durability, wettability, elasticity, or other physical and/or chemical traits that are desired.

Selection of an overmold material as the covering material 52 may be based upon the desirability of a chemical bond between the frame 50 and the covering material 52. Such a chemical bond may be desirable for durability of the resulting overmolded sensor 10. For example, to prevent separation of the covering material 52 from the frame 50, a covering material 52 may be selected which bonds with some or all of the frame 50 once overmolded. In such embodiments, the covering material 52 and the portions of the frame

50 to which the covering material 52 is bonded are not separable, i.e., they form one continuous and generally inseparable structure.

Furthermore, in embodiments in which the covering material 52 employed is liquid or fluid tight, the sensor 10 may be easily maintained, cleaned, and/or disinfected by immersing the sensor into a disinfectant or cleaning solution or by rinsing the sensor 10 off, such as under running water. For example, in an open configuration of the sensor 10, as depicted in Fig. 2A, the sensor 10 may be immersed or rinsed with water or a disinfectant solution for easy cleaning. Of course, the sensor 10 may be cleaned in either the closed or open configuration. In particular, the covered sensor 10 may be generally or substantially free of crevices, gaps, junctions or other surface irregularities typically associated with a multi-part construction which may normally allow the accumulation of biological detritus or residue. Such an absence of crevices and other irregularities may further facilitate the cleaning and care of the sensor 10.

In an embodiment in which the frame 50 is completely or substantially covered, the resulting sensor 10 is formed as a unitary or integral sensor assembly. In one embodiment, the sensor 10 is formed by an injection molding process. In such an embodiment the frame 50, may be positioned within a die or mold of the desired shape for the sensor 10. A molten or otherwise unset overmold material may then be injected into the die or mold. For example, in one implementation, a molten thermoplastic elastomer at between about 400° F to about 450° F is injected into the mold. The overmold material may then be set, such as by cooling for one or more minutes or by chemical treatment, to form the sensor body about the frame 50. In certain embodiments, other sensor components, such as the emitter 22 and/or detector 24, may be attached or inserted into their respective housings or positions on the overmolded sensor body.

Alternatively, the optical components (such as emitter 22 and detector 24) and/or conductive structures (such as wires or flex circuits) may be placed on the frame 50 prior to overmolding. The frame 50 and associated components may then be positioned within a die or mold and overmolded, as previously described. To protect the emitter 22, detector 24, and or other electrical components, conventional techniques for protecting such components from excessive temperatures may be employed. For example, the emitter 22 and/or the detector 24 may include an associated clear window 54, such as a

plastic or crystal window, in contact with the mold to prevent coating from being applied over the window. In one embodiment, the material in contact with such windows may be composed of a material, such as beryllium copper, which prevents the heat of the injection molding process from being conveyed through the window to the optical components. For example, in one embodiment, a beryllium copper material initially at about 40°F is contacted with the windows associated with the emitter 22 and/or detector 24 to prevent coating of the windows and heat transfer to the respective optical components.

As will be appreciated by those of ordinary skill in the art, the injection molding process described herein is merely one technique by which the frame 50 may be covered to form a sensor body, with or without associated sensing components. Other techniques which may be employed include, but are not limited to, dipping the frame 50 into a molten or otherwise unset coating material to coat the frame 50 or spraying the frame 50 with a molten or otherwise unset coating material to coat the frame 50. In such implementations, the coating material may be subsequently set, such as by cooling or chemical means, to form the coating. Such alternative techniques, to the extent that they may involve high temperatures, may include thermally protecting whatever optical components are present, such as by using beryllium copper or other suitable materials to prevent heat transfer through the windows associated with the optical components, as discussed above.

The frame 30 may be covered by other techniques as well. For example, the covering material 52 may be a sheet, a sleeve, or a film material which is applied to the frame. Such a covering material 52 may be bonded, such as with an adhesive material, or mechanically fastened to the frame 50. For instance, a suitable film material may be an extruded or laminated film that is adhesively or mechanically bonded to the frame 50. Likewise, a suitable sheet material may be a single or multi-layer sheet material that is adhesively or mechanically bonded to the frame 50. Other exemplary covering material 52 include cast, foamed, or extruded materials suitable for attachment to the frame 50.

By such techniques, the frame 50, as well as the optical components and associated circuitry where desired, may be encased in a covering material 52 to form the sensor 10 or a sensor body to which one or more of the optical components may be added. Such a sensor 10 may be fitted to the finger, toe, ear, or other appendage of a patient when

the sensor 10 is in a closed configuration. To facilitate the fitting process, a retaining component 64 may be provided to secure the sensor 10 in a closed configuration for clinical use. For example, in the embodiment of Figs. 2A and 2B a retaining component 64 in the form of locking tabs 66 is provided. The locking tabs 66 may be formed as a part of the frame 50 which may or may not be covered. Alternatively, the locking tabs 66 may be formed from the covering material 52 or may be a separate component that is configured to be attached to the sensor 10 prior to use on a patient.

As will be appreciated by those of ordinary skill in the art, the retaining component 64, such as locking tabs 66, may be composed of a material or a combination of materials that provide the desired elasticity and resistance, such as polymeric materials (rubber, plastic, and so forth) or metals. Likewise, the retaining component 64 may take other forms than the exemplary locking tabs 66. For example, referring now to Fig. 3, a sensor 10 is depicted in which the retaining component 64 is an elastic band 70 configured to hold the sensor 10 in a closed configuration. The elastic band 70 may be formed separate from the remainder of the sensor 10 and applied prior to use. Alternatively, the elastic band 70 may be formed integrally with the sensor 10, such as in the form of an elastic strap that may be adjustably secured to maintain the sensor 10 in the desired configuration. Likewise the elastic band 70 may interface with the surface of the sensor 10 with or without an adhesive layer and/or a mechanical retention mechanism to facilitate the retention of the elastic band 70 to the sensor 10.

As will be appreciated by those of ordinary skill in the art, the retaining force provided by the retaining component 64 may be overcome or removed by a clinician in order to remove the sensor 10 from a patient or to adjust the fit of the sensor. In addition, within certain embodiments, the retaining component 64 may provide varying degrees of retention and/or separation of the top and bottom portions 56, 58 of the sensor 10. For example, in embodiments where the retaining component 64 is an elastic band 70, the elasticity of the band 70 may allow a range of retention such that different sized fingers or other digits may be accommodated by the sensor 10. Likewise, in embodiments where the retaining component 64 is provided as locking tabs 66, the locking tabs 66 may be provided with more than one locked or engaged position to provide a range of retained

positions for the sensor 10. In this manner, the sensor 10 may be comfortably and conformably fitted to a patient's finger, toe, ear, and so forth.

Other retaining components or arrangements that provide similar benefits are also possible. For example, referring now to Figs. 4A and 4B, a covered sensor 10 is depicted
5 having a retaining component 64 in the form of a snap fit 74. The snap fit 74 may be formed from a portion of the frame 50 that is not covered or may be formed from a portion of the covering material 52, such as a portion of an overmold material having a greater durometer than the portion configured to come in contact with a patient. As depicted in Fig. 4A, the sensor 10 may be formed or provided in an open configuration, as
10 discussed above. As depicted in Fig. 4B, the top portion 56 and bottom portion 58 may be pivoted about hinge region 60 toward a closed configuration. Once in the closed configuration the depicted snap fit 74 engages a fitted region 76 configured to conform to and complement the snap fit 74 to form a secure fit. The fitted region 76 may be formed
15 from a portion of the covering material 52 shaped to engage the snap fit 74 and/or may be formed from a portion of the covering material having a durometer sufficient to form a good fit with the snap fit 74 but sufficiently compliant to be engaged by the snap fit 74.

Similarly, referring now to Figs. 5A and 5B, the retaining component 64 may be formed by a first and a second portion 80, 82 of the sensor 10 which are configured to form an interference fit when engaged. In this embodiment, the sensor 10 may be formed
20 or adjusted to an open configuration, as depicted in Fig. 5A. Upon closing the sensor 10, such as about a finger 84, the first portion 80, here depicted as the male portion of the interference fit, is interferingly engaged with the second portion, i.e., the female portion of the interference fit. The first portion 80 and/or the second portion 82 may be formed from
25 respective portions of the frame 50 that are not covered or may be formed from respective portions of the covering material 52 having suitable durometers for the formation of the interference fit.

In addition, as illustrated in Fig. 5A, flaps or side extensions 88 of the covering material 52 on the sides of the sensor 10 are depicted which facilitate the exclusion of
30 environmental or ambient light from the interior of the sensor 10. Such extensions help prevent or reduce the detection of light from the outside environment, which may be inappropriately detected by the sensor 10 as correlating to the SaO_2 . Thus, the pulse

oximetry sensor may detect differences in signal modulations unrelated to the underlying SaO₂ level. In turn, this may impact the detected red-to-infrared modulation ratio and, consequently, the measured blood oxygen saturation (SpO₂) value. The conformability of the fit of sensor 10 and the use of side extensions 88, therefore, may help prevent or
5 reduce such errors.

While the exemplary sensors 10 discussed herein are provided as examples, other such devices are also contemplated and fall within the scope of the present disclosure. For example, other medical sensors and/or contacts applied externally to a patient may be advantageously applied using a sensor body as discussed herein. Examples of such
10 sensors or contacts may include glucose monitors or other sensors or contacts that are generally held adjacent to the skin of a patient such that a conformable and comfortable fit is desired. Similarly, and as noted above, devices for measuring tissue water fraction or other body fluid related metrics may utilize a sensor as described herein. Likewise, other spectrophotometric applications where a probe is attached to a patient may utilize a sensor
15 as described herein.

While the invention may be susceptible to various modifications and alternative forms, specific embodiments have been shown by way of example in the drawings and have been described in detail herein. However, it should be understood that the invention is not intended to be limited to the particular forms disclosed. Rather, the invention is to
20 cover all modifications, equivalents, and alternatives falling within the spirit and scope of the invention as defined by the following appended claims. Indeed, the present techniques may not only be applied to transmission type sensors for use in pulse oximetry, but also to retroflective and other sensor designs as well. Likewise, the present techniques are not limited to use on fingers and toes but may also be applied to placement
25 on other body parts such as in embodiments configured for use on the ears or nose.

CLAIMS

What is claimed is:

1. A sensor assembly, comprising:
5 a frame, wherein the frame is configured to move between an open and a closed configuration;
a covering provided over at least part of the frame;
at least one optical component disposed on the frame; and
a retaining component configured to hold the frame in the closed configuration when
10 engaged.
2. The sensor assembly of claim 1, wherein the covering comprises a sheet, a sleeve or a film material.
- 15 3. The sensor assembly of claim 1, wherein the covering is bonded to the frame.
4. The sensor assembly of claim 1, wherein the covering is mechanically fastened to the frame.
20
5. The sensor assembly of claim 1, wherein the covering comprises a thermoplastic elastomer.
6. The sensor assembly of claim 5, wherein the thermoplastic elastomer comprises at least one of a thermoplastic polyolefin, a thermoplastic vulcanizate alloy,
25 thermoplastic polyurethane, silicone, or a combination thereof.
7. The sensor assembly of claim 5, wherein the thermoplastic elastomer comprises an extruded or laminated film.
- 30 8. The sensor assembly of claim 1, wherein the retaining component is integral with the sensor assembly.

9. The sensor assembly of claim 1, wherein the retaining component is separable from the sensor assembly.

10. A sensor assembly, comprising:
5 a sensor body configured to move between an open and a closed position;
an emitter disposed on the sensor body;
a detector disposed on the sensor body; and
a retaining component configured to hold the sensor body in the closed configuration
when engaged.

10

11. A sensor assembly, comprising:
a frame configured to move between an open and a closed position;
an emitter disposed on the frame;
a detector disposed on the frame; and
15 a covering provided over at least part of the frame to form a sensor assembly.

15

12. A method of manufacturing a sensor, comprising:
situating an emitter and a detector on a frame; and
coating the frame with a coating material to form a sensor assembly, wherein the
20 frame is substantially open when coated.

20

13. A method for acquiring physiological data, comprising:
emitting two or more wavelengths of light from an emitter of a sensor assembly,
wherein the sensor assembly is held in a closed configuration by one or more retaining
25 components;
detecting transmitted or reflected light using a photodetector of the sensor assembly;
and
determining a physiological parameter based on the detected light.

25

14. A retaining component for use on a sensor assembly, comprising:
an elastic band configured to hold a sensor body in a substantially closed
configuration.

5 15. A method of manufacturing a sensor body, comprising:
coating a frame with a coating material to form a sensor body, wherein the frame is
substantially open when coated.

10 16. A sensor body, comprising:
a frame, wherein the frame is configured to move between an open and a closed
configuration;
a covering provided over at least part of the frame; and
a retaining component configured to hold the frame in the closed configuration when
engaged.

15 17. A sensor body, comprising:
a sensor body configured to move between an open and a closed position; and
a retaining component configured to hold the sensor body in the closed configuration
when engaged.

20 18. A sensor body, comprising:
a frame configured to move between an open and a closed position; and
a covering provided over at least part of the frame to form a sensor assembly.

25 19. A frame of a sensor, comprising:
a frame configured to move between an open and a closed configuration; and
a retaining component configured to hold the frame in the closed configuration when
engaged.

20. A method for manufacturing a frame of a sensor, comprising:
forming a frame configured to move between an open and a closed configuration,
wherein the frame comprises a retaining component configured to hold the frame in the
closed configuration when engaged.

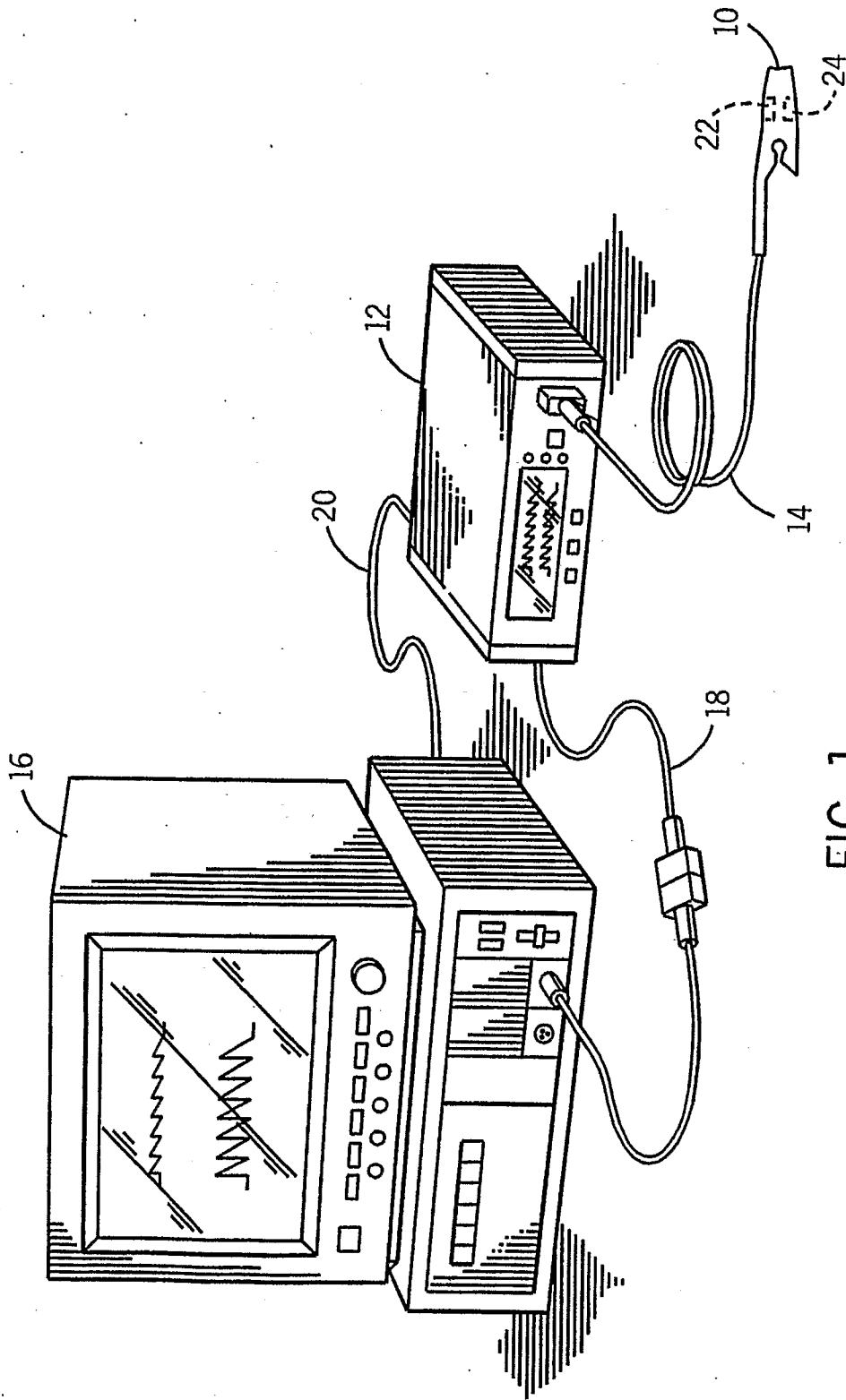

FIG. 1

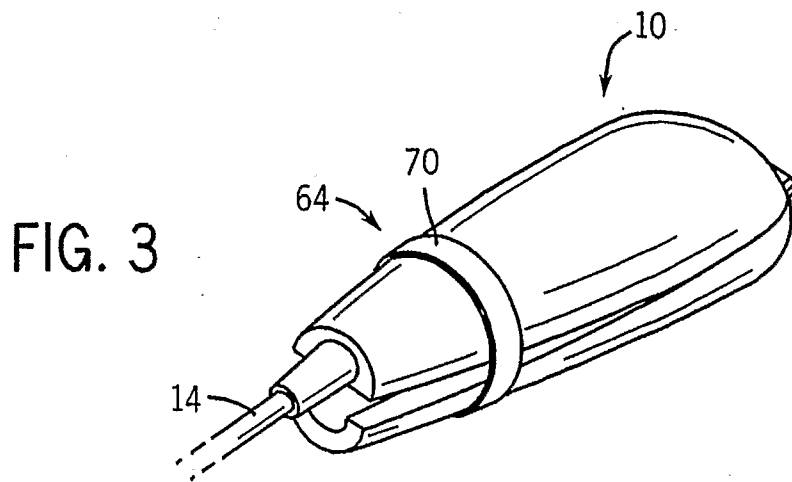
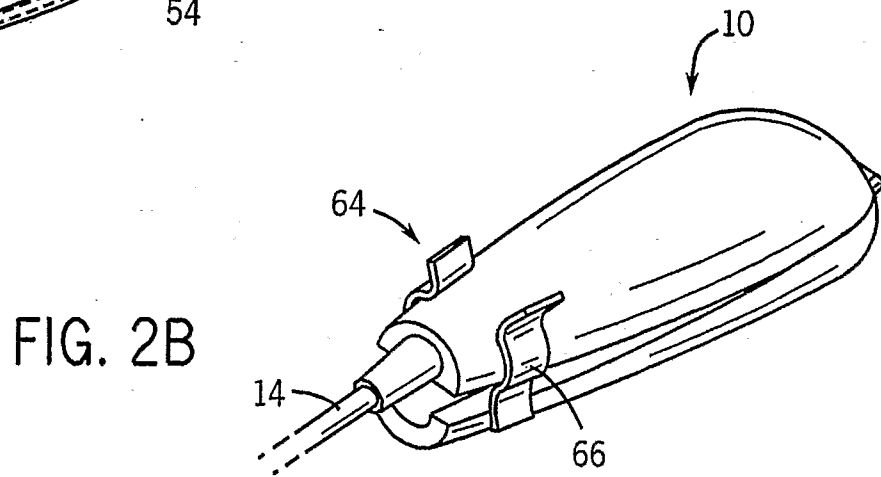
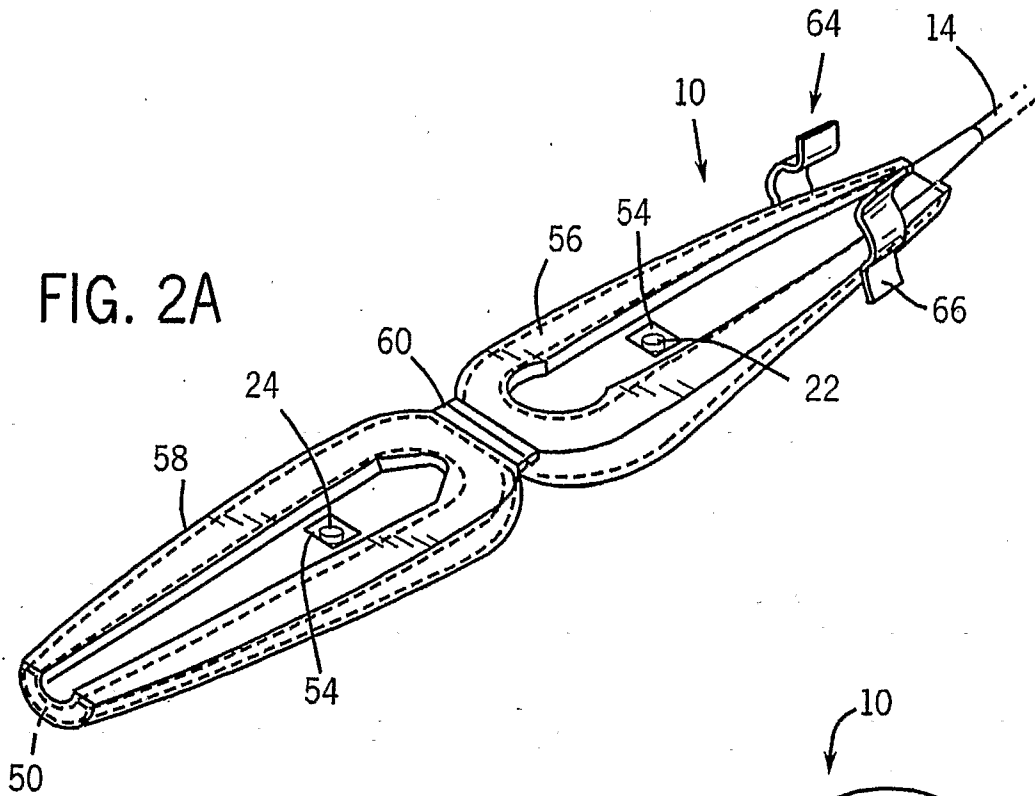

FIG. 4A

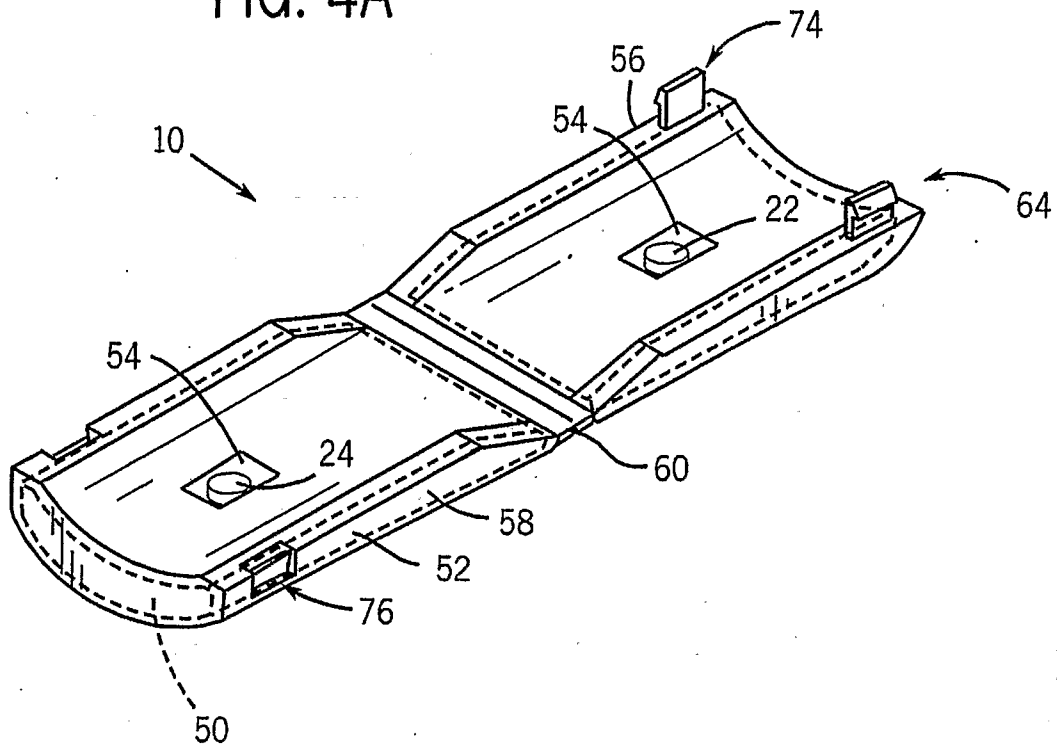
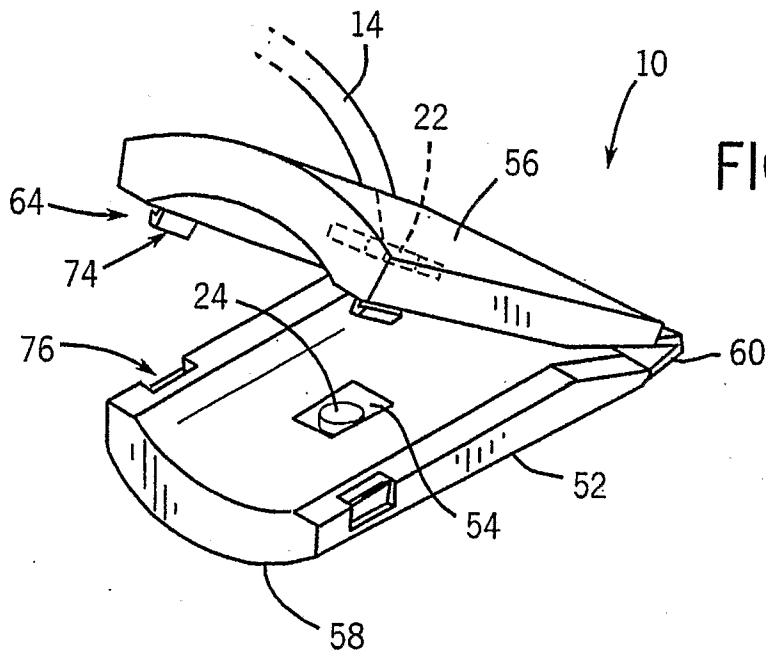

FIG. 4B



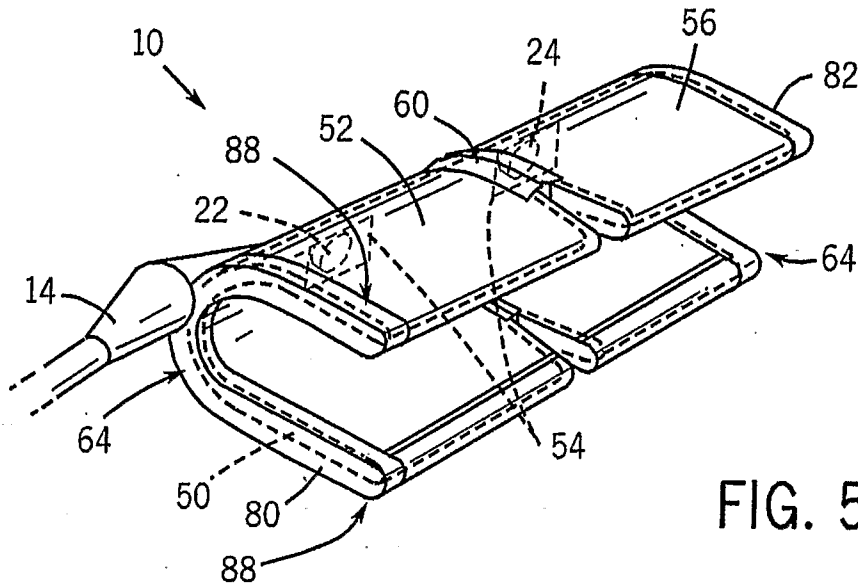

FIG. 5A

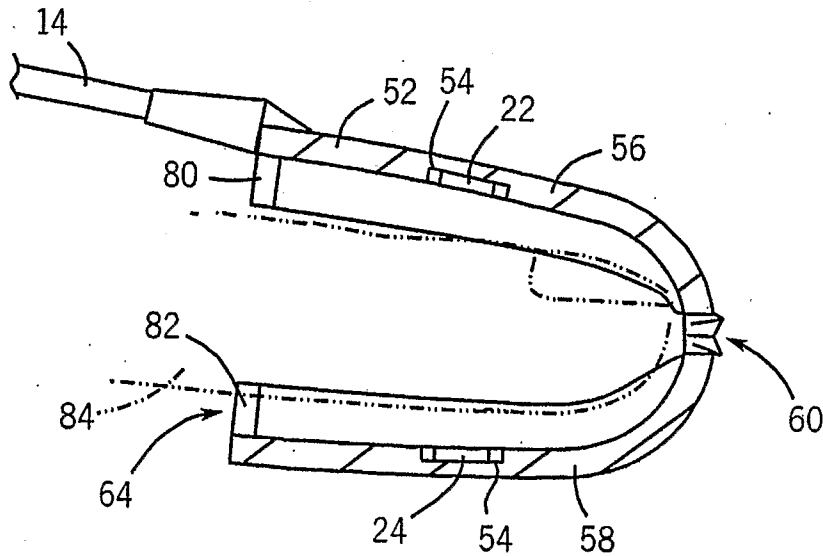

FIG. 5B