

(19) World Intellectual Property Organization
International Bureau



(43) International Publication Date
17 April 2008 (17.04.2008)

PCT

(10) International Publication Number
WO 2008/043177 A1

(51) International Patent Classification:

G01L 19/08 (2006.01) G01L 19/00 (2006.01)
G01L 19/14 (2006.01)

(74) Agent: KNOX, John W.; SMART & BIGGAR Box
11560, Vancouver Centre 650 West Georgia Street, Suite
2200, Vancouver, British Columbia V6B 4N8 (CA).

(21) International Application Number:

PCT/CA2007/001811

(81) Designated States (unless otherwise indicated, for every
kind of national protection available): AE, AG, AL, AM,
AT, AU, AZ, BA, BB, BG, BH, BR, BW, BY, BZ, CA, CH,
CN, CO, CR, CU, CZ, DE, DK, DM, DO, DZ, EC, EE, EG,
ES, FI, GB, GD, GE, GH, GM, GT, HN, HR, HU, ID, IL,
IN, IS, JP, KE, KG, KM, KN, KP, KR, KZ, LA, LC, LK,
LR, LS, LT, LU, LY, MA, MD, ME, MG, MK, MN, MW,
MX, MY, MZ, NA, NG, NI, NO, NZ, OM, PG, PH, PL,
PT, RO, RS, RU, SC, SD, SE, SG, SK, SL, SM, SV, SY,
TJ, TM, TN, TR, TT, TZ, UA, UG, US, UZ, VC, VN, ZA,
ZM, ZW.

(22) International Filing Date: 11 October 2007 (11.10.2007)

(25) Filing Language: English

(26) Publication Language: English

(30) Priority Data:
11/580,693 13 October 2006 (13.10.2006) US

(71) Applicant (for all designated States except US): SMAR-
TIRE SYSTEMS INC. [CA/CA]; 13151 Vanier Place,
Suite 150, Richmond, British Columbia V6V 2J1 (CA).

(84) Designated States (unless otherwise indicated, for every
kind of regional protection available): ARIPO (BW, GH,
GM, KE, LS, MW, MZ, NA, SD, SL, SZ, TZ, UG, ZM,
ZW), Eurasian (AM, AZ, BY, KG, KZ, MD, RU, TJ, TM),
European (AT, BE, BG, CH, CY, CZ, DE, DK, EE, ES, FI,
FR, GB, GR, HU, IE, IS, IT, LT, LU, LV, MC, MT, NL, PL,
PT, RO, SE, SI, SK, TR), OAPI (BF, BJ, CF, CG, CI, CM,
GA, GN, GQ, GW, ML, MR, NE, SN, TD, TG).

(72) Inventors; and

(75) Inventors/Applicants (for US only): SHEIKH-BA-
HAIE, Kian [CA/CA]; 117 Parkside Drive, Port Moody,
British Columbia V3H 4W8 (CA). LAMMERS, Shawn
[CA/CA]; 10540 Suncrest Drive, Delta, British Colum-
bia V4C 2N5 (CA). PATTERSON, Robert Gordon
[CA/CA]; 6550 Clinton Street, Burnaby, British Columbia
V5E 1A4 (CA).

Published:
— with international search report

(54) Title: FLUID PRESSURE SENSING METHOD AND APPARATUS

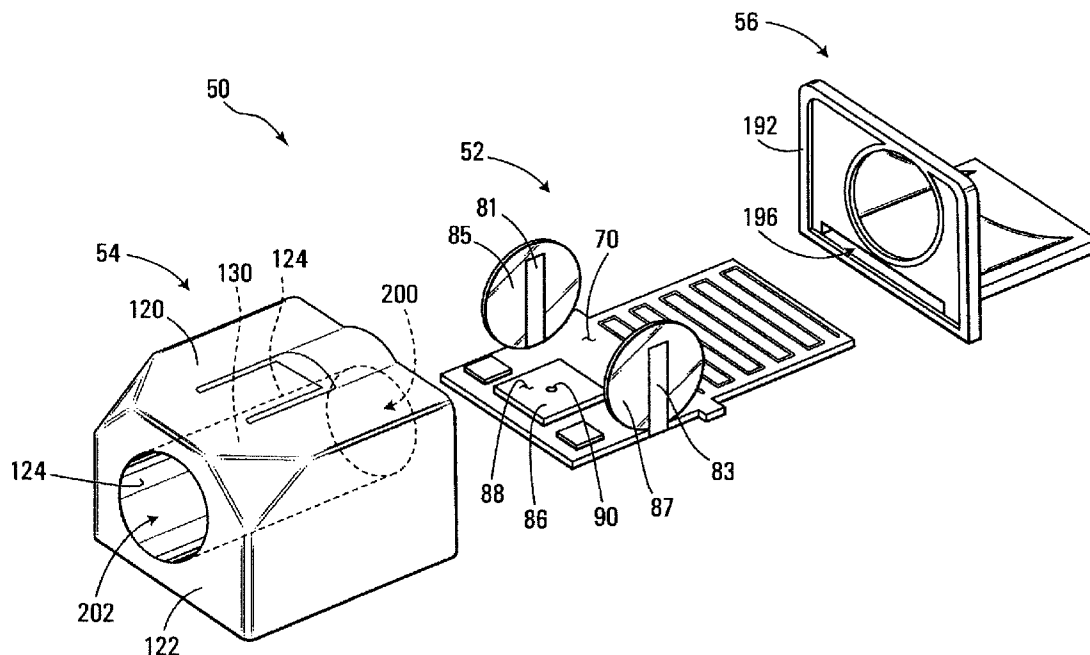

(57) Abstract: A method and apparatus for producing a circuit carrier for mounting components of a pressure sensing circuit, circuit carrier formed thereby, an apparatus for housing a pressure sensor circuit carrier to form a pressure sensing apparatus and a pressure sensing system using the pressure sensing apparatus and a coupler for coupling the pressure sensing apparatus to a pressurized system. A housing has provisions for aligning and urging a circuit carrier to sealingly position a pressure sensor adjacent an opening in a wall extending through of housing. The wall defines a pressure sensing chamber operable to cooperate with a pressure coupler having a profile that sealingly engages the wall.

WO 2008/043177 A1

FLUID PRESSURE SENSING METHOD AND APPARATUS

BACKGROUND OF THE INVENTION

1. Field of Invention

5 This invention relates to a fluid pressure sensing method and apparatus and components thereof.

2. Description of Related Art

10 Pressure sensors for pressurized systems are known. Some pressure sensors are designed for permanent installation on a pressurized system and may have a pipe coupling or hose coupling to facilitate connection to the system. Often, screw threads are involved on such couplings and threaded engagement with the coupling secures the pressure sensor thereto.

15 One example of an area where such sensors are used is in vehicle tire pressure monitoring. Typically, pressure sensors for tire pressure monitoring are formed with housings that have a cylindrical protrusion having an inside threaded wall for engagement with an outside threaded portion of a valve stem on a tire. Typically, the tire is filled with air and then the pressure sensor
20 is screwed on to the valve stem in such a manner that it cooperates with a valve actuator in the valve stem to cause pressurized fluid in the tire to be communicated to the pressure sensor.

25 A problem with the above type of sensor is that it must be removed to allow access to the valve in the valve stem in order to change the air pressure in the tire. This can be time consuming, especially where there are individual sensors on each wheel of a large transport truck for example.

-2-

SUMMARY OF THE INVENTION

In accordance with one aspect of the invention, there is provided a method of producing a circuit carrier for mounting components of a pressure sensing circuit. The method involves forming on a substrate a circuit portion and an antenna portion. Forming the antenna portion involves forming a radio frequency antenna on the antenna portion. The method further involves forming the circuit portion which involves causing at least one power supply mount for a power supply for the pressure sensing circuit to be formed at a side of the substrate such that the power supply projects outwardly from the substrate. Forming the circuit portion also involves causing a pressure sensor mount to be formed on the substrate such that when a pressure sensor is mounted to the mount a flat surface about a sensor opening of the pressure sensor is generally parallel and spaced apart from a first surface of the substrate and is adjacent the power supply. Forming the circuit portion further involves causing ancillary component mounts to be formed in the circuit portion, the ancillary component mounts being operable to facilitate mounting of ancillary components for effecting a transmitter function. Forming the circuit portion also involves causing circuit interconnections between the at least one power supply mount, the pressure sensor mount and the ancillary component mounts and the antenna to be formed on the substrate such that a pressure sensor mounted to the pressure sensor mount and ancillary components mounted to the ancillary component mounts are operable to receive power from a power supply mounted to the power supply mount and such that when the pressure sensor and ancillary components receive power from the power supply the transmitter function is effected, the transmitter function being operable to produce a transmittable signal in response to a pressure signal received from the pressure sensor, the transmittable signal being operable to be radiated by the antenna, for wireless reception by a remote receiver.

30 The power supply mount may include a battery mount.

-3-

The battery mount may include first and second battery mounts on opposite sides of the substrate, the pressure sensor mount being located between the first and second battery mounts.

5 The first and second battery mounts may be operably configured to facilitate mounting of disk-shaped batteries such that axes of the disk shaped batteries are generally parallel to a top surface of the substrate.

10 Forming the circuit portion and the antenna portion may involve causing the circuit portion to be located on a first end of the substrate and causing the antenna portion to be located on a second end of the substrate.

Forming the antenna portion may involve forming a serpentine conductor on the second end of the substrate.

15 Causing the ancillary component mounts to be formed in the circuit portion may involve causing switch contacts to be formed on the substrate, for mounting a switch thereto, and causing the circuit interconnections to be formed on the substrate comprises causing the circuit interconnections to connect the switch
20 contacts to at least one of the ancillary component mounts, the power supply mount and the pressure sensor mount.

25 Causing the switch contacts to be formed on the substrate may involve causing the switch contacts to be formed on a second surface of the substrate, wherein the second surface is generally parallel and spaced apart from the first surface.

30 Producing a pressure sensor circuit assembly may involve installing a power supply on the power supply mount of the circuit carrier and installing a pressure sensor on the pressure sensor mount of the circuit carrier, and installing ancillary components on the ancillary component mounts of the circuit carrier, such that the ancillary components are operable to effect the transmitter function.

-4-

Housing the pressure sensor circuit assembly may involve receiving the circuit portion in a cavity of a body having a wall defining a pressure sensing chamber such that the opening in the pressure sensor is aligned with an opening in the pressure chamber. The method may further involve urging the substrate in a direction tending to press the flat surface of the pressure sensor against a seal between the flat surface and a portion of the wall defining the pressure chamber, such that the opening in the pressure sensor is in fluid communication with the opening in the pressure chamber and such that the seal prevents ambient pressure from interfering with communication of fluid between the opening in the pressure sensor and the opening in the pressure chamber.

Receiving may involve aligning the opening in the pressure sensor with the opening in the pressure chamber.

Aligning may involve guiding the circuit assembly into a position relative to the pressure chamber such that the opening in the pressure sensor is aligned with the opening in the pressure chamber.

Guiding may involve confining lateral movement of the circuit assembly.

Guiding may involve guiding edges on opposite sides of the substrate to position the substrate relative to the pressure chamber while the substrate is moved into the cavity.

Urging may involve applying a force to a second surface of the substrate, the second surface being opposite the first surface.

Applying the force may involve causing the second surface of the substrate to bear upon a support in the cavity.

-5-

Causing the second surface of the substrate to bear upon the support may involve causing the second surface to bear upon first and second spaced apart supports.

5 The method may involve holding a resilient switch actuator adjacent switch contacts formed on the substrate.

Holding may involve receiving the switch actuator in an opening in the outer wall.

10

Holding may involve fastening a holder to the outer wall such that a surface of the switch actuator is accessible from outside the body.

15 In accordance with another aspect of the invention, there is provided a circuit carrier apparatus for a fluid pressure sensor. The apparatus includes a substrate having first and second opposite edges, first and second opposite ends and first and second opposite facing surfaces. The apparatus also includes a circuit portion on the first end and an antenna portion on the second end. The antenna portion includes a radio frequency antenna. The circuit portion may include at least one power supply mount for a power supply for the pressure sensing circuit, the power supply mount being located at a side of the substrate and such that the power supply projects outwardly from the substrate. The circuit portion may also include a pressure sensor mount formed on the substrate such that when a pressure sensor is mounted to the mount, a flat surface about a sensor opening on the pressure sensor is generally parallel and spaced apart from the first opposite facing surface and is adjacent the power supply. The circuit portion further includes ancillary component mounts formed in the circuit portion, the ancillary component mounts being operable to facilitate mounting of ancillary components for effecting a transmitter function. The circuit portion also includes circuit interconnections between the at least one power supply mount, the pressure sensor mount, the ancillary component mounts and the antenna such that a pressure sensor mounted to the pressure sensor mount and ancillary

20

25

30

-6-

components mounted to the ancillary component mounts are operable to receive power from a power supply mounted to the power supply mount and such that when the pressure sensor and ancillary components receive power from the power supply a transmitter function is effected, the transmitter function is operable to produce a transmittable signal in response to a pressure signal received from the pressure sensor, the transmittable signal being operable to be radiated by the antenna, for wireless reception by a remote receiver.

10 The power supply mount may include a battery mount.

The battery mount may include first and second battery mounts on opposite sides of the substrate, the pressure sensor mount being located between the first and second battery mounts.

15 The first and second battery mounts are operably configured to facilitate mounting of disk-shaped batteries such that axes of the disk shaped batteries are generally parallel to a top surface of the substrate.

20 The antenna portion may involve a serpentine conductor on the second end of the substrate.

25 The apparatus may include switch contacts formed on the substrate, for cooperating with a switch contactor, the switch contacts being connected by the circuit interconnections to at least one of the ancillary component mounts, the power supply mount and the pressure sensor mount.

The switch contacts may be formed on the second surface of the substrate.

30 The pressure sensor circuit apparatus may include the circuit carrier and may also include a power supply installed on the power supply mount, a pressure sensor installed on the pressure sensor mount and ancillary components

-7-

installed on the ancillary component mounts, such that the ancillary components are operable to effect the transmitter function.

5 In accordance with another aspect of the invention, there is provided an apparatus for housing a pressure sensor circuit. The apparatus includes a body which may include an outer wall defining a cavity operably configured to hold a substrate carrying a pressure sensor having a pressure sensing opening. The body also includes an inner wall inside the cavity defining a pressure sensing chamber, an opening in the inner wall, and a seal interface about the opening.

10 The body further includes aligning provisions for aligning the pressure sensor opening with the opening in the inner wall to provide for communication of fluid between the pressure sensing chamber and the pressure sensor opening. The body also includes urging provisions for urging the pressure sensor against a seal adjacent the seal interface, such that the opening in the pressure sensor is

15 in fluid communication with the opening in the inner wall and such that the seal prevents ambient pressure from interfering with communication of fluid between the opening in the pressure sensor and the opening in the inner wall.

The aligning provisions may include guiding provisions for guiding the substrate

20 into a position in which the opening in the pressure sensor is aligned with the opening in the inner wall.

The guiding provisions may include stops operable to contact the first and second sides of the substrate for confining lateral movement of the circuit

25 assembly.

The first and second sides of the substrate may have first and second edges respectively, and the stops may include first and second stops operably configured to bear on the first and second edges to laterally position the

30 substrate relative to the inner wall.

-8-

The urging provisions may include provisions for applying a force on the second opposite surface of the substrate.

5 The provisions for applying a force may include a support on the outer wall of the body and facing inside the cavity, wherein the second opposite surface of the substrate to bears upon the support.

10 The support may include first and second spaced apart supports on the outer wall and facing into the cavity, wherein the second opposite surface of the substrate to bears upon the fist and second supports.

15 The apparatus may further include holding provisions for holding a resilient switch actuator in the outer wall such that the switch actuator is operable to make contact with switch contacts formed on the second opposite surface of the substrate.

The holding provisions may include a switch opening and the switch opening may be operable to receive the switch actuator.

20 The holding provisions may further include a flat member having an opening permitting access to a surface of the switch actuator, the flat member being fastened to the body such that the resilient switch actuator provides a seal to prevent ingress and egress of fluid relative to the cavity through the switch actuator opening.

25 In accordance with another aspect of the invention, there is provided a pressure sensor apparatus. The pressure sensor apparatus includes a circuit carrier apparatus including a substrate having first and second opposite edges, first and second opposite ends and first and second opposite facing surfaces. The apparatus also includes a circuit portion on the first end and an antenna portion
30 on the second end. The antenna portion includes a radio frequency antenna and the circuit portion includes at least one power supply located at a side of the

substrate and such that the power supply projects outwardly from the substrate. The circuit portion also includes a pressure sensor having a flat surface and a pressure sensor opening on the flat surface, the flat surface being generally parallel and spaced apart from the first opposite facing surface and adjacent the power supply. The circuit portion further includes a transmitter connected to the pressure sensor for producing a signal for radiation by the antenna in response to a sense signal produced by the pressure sensor. The pressure sensor apparatus includes a housing for housing the circuit carrier apparatus. The housing includes a body that has an outer wall defining a cavity operably configured to hold the circuit portion of the substrate. The body also has an inner wall inside the cavity defining a pressure sensing chamber, an opening in the inner wall, a seal about the opening and aligning provisions for aligning the pressure sensor opening with the opening in the inner wall to provide for communication of fluid between the pressure sensing chamber and the pressure sensor opening. The body further has urging provisions for urging the pressure sensor against the seal, such that the opening in the pressure sensor is in fluid communication with the opening in the pressure sensing chamber and such that the seal prevents ambient pressure from interfering with communication of fluid between the opening in the pressure sensor and the opening in the pressure sensing chamber. The housing also includes potting material in the cavity and about the circuit portion for securing the substrate in the cavity. The housing further includes a cover for covering the antenna portion, the cover being sealingly engaged with the housing to prevent ingress and egress of fluid relative to the cavity.

The inner wall may define a first opening into the pressure sensing chamber, the first opening being operable to receive a pressure coupling for coupling fluid pressure from a pressurized system to the pressure sensing chamber.

The outer wall may define a second opening into the pressure sensing chamber, the second opening being generally coaxial with the first opening to permit a projection on the pressure coupling to be inserted into the first opening to extend

-10-

through the pressure sensing chamber such that a portion of the pressure coupling extends out of the second opening.

5 The aligning provisions may involve guiding provisions for guiding the substrate into a position in which the opening in the pressure sensor is aligned with the opening in the inner wall.

10 The guiding provisions may involve stops operable to contact the first and second sides of the substrate for confining lateral movement of the circuit assembly.

15 The first and second sides of the substrate may have first and second edges respectively, and the stops may include first and second stops operably configured to bear the first and second edges to laterally position the substrate relative to the inner wall.

The urging provisions may include provisions for applying a force to the second opposite surface of the substrate.

20 The provisions for applying a force may include a support on the outer wall of the body, the support facing inside the cavity, the second opposite surface of the substrate bearing upon the support.

25 The support may include first and second spaced apart supports on the outer wall and facing into the cavity, wherein the second opposite surface of the substrate to bears upon the support.

30 The circuit portion may include switch contacts formed on the second opposite facing side of the substrate, the switch contacts being operably connected to the pressure sensor and the apparatus may further comprise a resilient switch actuator and holding provisions for holding the resilient switch actuator in the

-11-

outer wall such that the switch actuator is operable to make contact with the switch contacts.

5 The holding provisions may include a switch opening holding the switch actuator.

10 The holding provisions may further include a flat member having an opening permitting access to a surface of the switch actuator the flat member being fastened to the body such that the resilient switch actuator provides a seal to prevent ingress and egress of fluid relative to the cavity through the switch actuator opening.

15 In accordance with another aspect of the invention, there is provided a pressure sensing system including the pressure sensor apparatus above and a pressure coupler operably configured to communicate with the pressure sensing chamber of the pressure sensor apparatus above to communicate fluid pressure to the pressure sensor.

20 The pressure coupler may include a projection having an inlet opening operably configured to communicate with a pressurized system to receive pressurized fluid therefrom, and the projection and the pressure sensing chamber may be operably configured such that the projection is sealingly received in the pressure sensing chamber and such that fluid entering the inlet opening is communicated to the pressure sensor through the pressure sensing chamber.

25 Other aspects and features of the present invention will become apparent to those ordinarily skilled in the art upon review of the following description of specific embodiments of the invention in conjunction with the accompanying figures.

30

BRIEF DESCRIPTION OF THE DRAWINGS

In drawings which illustrate embodiments of the invention,

- 5 **Figure 1** is a perspective view of a pressure sensing system according a first embodiment of the invention.
- Figure 2** is a cross-sectional view of a pressure sensor apparatus of the pressure sensing system of **Figure 1** connected to a pressure coupler.
- 10 **Figure 3** is an exploded perspective view of the pressure sensor apparatus shown in **Figure 1**.
- Figure 4** is a perspective view of a circuit carrier apparatus of the pressure sensor apparatus shown in **Figure 1**.
- 15 **Figure 5** is a perspective view of an underside of the circuit carrier apparatus shown in **Figure 4**.
- Figure 6** is a rear end view of a housing of the pressure sensor apparatus shown in **Figure 1**.
- 20 **Figure 7** is a perspective view showing a front, bottom, and left hand side of the housing shown in **Figure 6**.
- 25 **Figure 8** is a fragmented cross-sectional view of a portion of the housing shown in **Figure 6** with the circuit carrier apparatus disposed therein.
- 30 **Figure 9** is an exploded perspective view of the housing shown in **Figure 6**, with the circuit carrier apparatus installed therein, and ready to

-13-

receive a cover for sealing the circuit carrier apparatus within the housing.

5 **Figure 10** is a cross-sectional view of a pressure coupler according to a first alternative embodiment of the invention.

Figure 11 is a cross-section view of a pressure coupler according to a second alternative embodiment of the invention.

10 **Figure 12** is a cross-sectional view of a pressure coupler according to a third alternative embodiment of the invention.

Figure 13 is a cross-sectional view of a pressure coupler according to a fourth alternative embodiment of the invention.

15 **Figure 14** is a cross-sectional view of a pressure coupler according to a fifth alternative embodiment of the invention.

DETAILED DESCRIPTION

20 Referring to **Figure 1**, a pressure sensing system according to a first embodiment of the invention is shown generally at **10** and includes a pressure sensor apparatus **11** mounted on a pressure coupler shown generally at **12**.

25 Referring to **Figure 2**, the pressure coupler **12** in this embodiment includes a body **13** having an inlet opening **14** for receiving pressurized fluid from a pressurized system. In one embodiment, the pressurized system may include a tire (not shown) having a valve stem **17** operable to be received in the inlet opening **14**. In such an embodiment, the inlet opening **14** may be threaded as shown at **18**, for example, to receive corresponding threads **20** of
30 an end of the valve stem **17**.

-14-

In this embodiment, the body **13** also has a projection **16** having first and second passages **22** and **24** in communication with the inlet opening **14** which are connected to and in communication with a valve bore **26** operable to receive a valve core **28** in sealing engagement therein.

5

Adjacent the passages **22** and **24**, a solid portion **30** of the body is disposed approximately centrally in a bottom portion of the inlet opening **14** to bear upon a valve actuator **32** of the valve stem **17** when the threads **20** on the valve stem **17** are fully engaged with the threads **18** of the inlet opening **14**.

10

Thus, the valve of the valve stem **17** is opened as the valve stem is screwed into the inlet opening **14** by action of the valve actuator **32** being pressed inwardly due to it bearing upon the solid portion **30** as the pressure coupler is threaded thereon. Fluid in the tire with which the valve stem **17** is in communication, is operable to pass through the passages **22** and **24** to the valve bore **26**. A further passageway **33** provides for communication between the valve bore **26** and an external opening **34** on an exterior surface **36** of the projection **16**.

15

20

Referring to Figure **3**, the pressure sensor apparatus is shown in greater detail at **50** and includes a circuit carrier apparatus shown generally at **52**, a housing shown generally at **54** for housing the circuit carrier apparatus and a cover **56** for covering a portion of the circuit carrier apparatus.

25

Referring to Figure **4**, the circuit carrier apparatus **52** includes a substrate **60** which, in this embodiment, includes a printed wiring board. The substrate **60** has first and second opposite edges **62** and **64**, first and second opposite ends **66** and **68**, and first and second opposite facing surfaces **70** and **72** respectively. A circuit portion shown generally at **74** is located on the first end **66** of the substrate **60** and an antenna portion shown generally at **76** is located on the second end **68**. In this embodiment, the antenna portion **76** includes a radio frequency antenna shown at **78** comprised of a serpentine

30

-15-

conductor formed on a surface of the second end **68**. The serpentine conductor may be formed from an etched copper strip, for example.

5 The circuit portion **74** comprises, in this embodiment, first and second power supply mounts shown generally at **80** and **82** which, in this embodiment, are contact pads having through-holes through the substrate **60** for mounting pins of battery holders, for example to the substrate. In this embodiment, the first and second power supply mounts **80** and **82** are located on opposite sides of the substrate **60**, near the first and second edges **62** and **64** respectively so
10 that battery mounts such as battery holders **81** and **83** mounted thereto project upwardly from the first face surface **70** of the substrate to hold disk-shaped batteries **85** and **87** in an upright orientation, as shown in Figure **3** such that axes of the batteries are generally parallel to the first surface **70** of the substrate **60**.

15 Referring back to Figure **4**, the circuit portion **74** further comprises a pressure sensor mount shown generally at **84** which, in this embodiment, includes pads formed on the substrate to receive an integrated circuit pressure sensor such as an NPX-1 tire pressure sensor available from General Electric Industrial
20 Sensing of Billerica, MA, USA.

25 Referring back to Figure **3**, a pressure sensor **86** is shown mounted to the pressure sensor mount (**84**) and is located adjacent the power supply, and more particularly between the battery mounts **81** and **83**. The pressure sensor **86** has a flat surface **88** extending about a pressure sensing opening **90** on the pressure sensor. The flat surface **88** is generally parallel and spaced apart from the first face surface **70**.

30 Referring back to Figure **4**, the circuit portion **74** further includes ancillary component mounts, one of which is shown generally at **100**, for mounting ancillary components for effecting a transmitter function. Such ancillary

-16-

components may include transistors, resistors, capacitors, and a crystal for example.

5 In addition, the circuit portion **74** includes circuit interconnections, one of which is shown at **102**, operably configured to extend between the power supply mounts **80** and **82**, the pressure sensor mount **84**, the ancillary component mounts **100** and the antenna **78** such that when the pressure sensor **86** is mounted to the pressure sensor mount **84** and ancillary components are mounted to the ancillary component mounts **100** these
10 components are operable to receive power from a power supply mounted to the power supply mounts **80** and **82** such that a transmitter function is effected. The circuit interconnections and ancillary components connected thereto implement any of a plurality of commonly known RF transmitter circuits operable to produce an RF signal that will be radiated by the antenna
15 portion **76**. The transmitter function causes a transmittable signal to be produced by the ancillary components, in response to a pressure signal received from the pressure sensor **86**. The transmittable signal is radiated by the antenna portion **76** for wireless reception by a remote receiver.

20 Referring to Figure 5, in this embodiment, the second opposite face surface **72** has switch contacts **104** and **106** comprised of generally c-shaped traces on the second face surface **72**. The switch contacts **104** and **106** have legs **108** and **110** that are juxtaposed to co-operate with a switch contactor shown in Figure 8. The switch contacts **104** and **106** are connected by circuit
25 interconnections to at least one of the ancillary component mounts **100**, the power supply mounts **80** and **82** and the pressure sensor mount **84** to facilitate closing and opening a circuit involving at least one of the ancillary components connected to the ancillary component mounts **100**, the power supply connected to the power supply mounts **80** and **82** and the pressure
30 sensor **86** connected to the pressure sensor mount **84**. For example, the switch contacts **104** and **106** may be connected to certain pins of the pressure

-17-

sensor **86** to open and close a circuit associated therewith so as to place the pressure sensor **86** into a desired state of operation.

5 Referring back to Figure 3, the housing **54** includes a body **120** having an outer wall **122** and an inner wall **124**. Referring to Figure 6, the outer wall defines a cavity **126** operably configured to hold the circuit carrier apparatus **52** as shown in broken outline at **128**. The inner wall **124** is inside the cavity **126** and defines a generally cylindrical pressure sensing chamber **130**. The inner wall **124** has an opening shown in broken outline at **132** extending
10 between the pressure sensing chamber **130** and the cavity **126**. A seal interface **134** is disposed about the opening **132** and, in this embodiment, includes a flat surface having an annular groove extending about the opening **132** seen best at **135** in Figure 8.

15 The body **120** further includes alignment provisions including guides in the form of first and second stops provided by rigid portions of plastic **136** and **138** on opposite sides of a lower portion of the cavity **126**. The rigid portions of plastic **136** and **138** act to laterally align the circuit carrier apparatus **52** such that the pressure sensing opening **90** in the pressure sensor **86**, is
20 aligned with the opening **132** in the inner wall **124** for communication of fluid between the pressure sensing chamber **130** and the pressure sensing opening shown at **90** in Figure 3.

25 The first and second rigid portions of plastic **136** and **138** are operable to contact the first and second sides of the substrate **60** and more particularly in this embodiment the first and second edges **62** and **64** respectively, of the substrate, for confining lateral movement of the circuit apparatus in the cavity **126**. This serves to laterally position the substrate relative to the inner wall **124**. Referring to Figures 4 and 5, first and second alignment tabs **131** and
30 **133** on opposite sides of the substrate also assist in aligning the substrate in the cavity **126**.

-18-

5 The body **120** further includes urging provisions **139** for urging the pressure sensor against a seal **140** adjacent the seal interface **134** such that the pressure sensing opening **90** in the pressure sensor **86** is in fluid communication with the opening **132** in the pressure sensing chamber **130** and such that the seal **140** prevents ambient pressure from interfering with communication of fluid between the pressure sensing opening **90** and the pressure sensor and the opening **132** in the inner wall **124**. In this embodiment the urging provisions act to provide a force on the second face surface **72** of the substrate **60**. In this embodiment, the force is provided by first and second spaced apart supports **142** and **144** on the outer wall **122** and which face into the cavity **126**. The first and second spaced apart supports **142** and **144** have leading inclined surfaces, only one of which is shown at **145** in Figure **8**. In effect, the first and second supports **142** and **144** push the second surface **72** of the substrate **60** toward the inner wall **124** and thereby press the flat surface **88** on the pressure sensor **86** against the seal **140** to thereby effect sealing about the opening **132** while permitting fluid communication between the opening **132** in the inner wall **124** and the pressure sensing opening **90** in the pressure sensor **86**.

20 Referring to Figures **5** and **6**, it will be appreciated that the switch contacts **104** and **106** are positioned adjacent the outer wall **122** shown in Figure **6** and between the first and second supports **142** and **144** and face toward the outer wall **122**.

25 Referring to Figure **7**, the housing **54** is formed with holding provisions shown generally at **150** for holding a switch actuator as shown at **152** in Figure **8** in the outer wall **122** such that the switch actuator **152** is operable to make contact with the switch contacts **104** and **106** formed on the second face surface **72** of the substrate. To do this, referring to Figure **7**, the outer wall **122** has a switch opening **154** with a generally flat annular surface **156** surrounding the switch opening **154**.

-19-

Referring to Figure 8, in this embodiment, the resilient switch actuator **152** is formed of a resilient, elastic material such as rubber and is formed to include a shaft portion shown generally at **158**, a head portion shown generally at **160**, and a body portion shown generally at **162**. The body portion has an annular recess **164** and a lower concaved surface **166** to which is connected an electrical contact **168** which is secured to the concaved surface **166** by adhesive, for example. The concaved surface **166** with the electrical contact **168** thereon is formed such that in the rest position shown in Figure 8, the electrical contact **168** is not in contact with the switch contacts **104** and **106** on the second face surface **72** of the substrate **60**.

The outer wall **122** has an inner cylindrical surface **170** defining the switch opening **154**. The switch opening **154** receives the switch actuator **152** such that the cylindrical surface **170** bears upon the body portion **162** of the switch actuator **152** in relatively tight engagement therewith. A plastic washer **172** having an opening defined by an inner cylindrical wall **174** is operable to receive the shaft portion **158** of the switch actuator such that the head portion **160** extends on one side of the plastic washer **172** while the body portion **162** extends on an opposite side of the plastic washer **172**. This permits the plastic washer with resilient switch actuator **152** secured thereto to be placed on the flat annular surface **156** and laser welded thereto to secure the switch actuator **152** in place, in the switch opening **154**. The opening defined by the cylindrical surface **174** permits access to a surface **155**, in this embodiment the head portion **160** of the switch actuator **152**, to enable a user to press the head of the actuator. Since the switch actuator **152** is formed of resilient elastic rubber, the shaft portion **158** is dimensioned to be about as long as the thickness of the plastic washer **172** such that the shaft portion **158** is held tightly in the opening of the plastic washer **172**. The head portion **160** is larger than the shaft portion **158** and prevents ingress of moisture and fluid through the opening **154**. The body portion **162** is also larger than the shaft portion and seals the opening **154** from inside the cavity **126**.

-20-

When a user presses the head portion **160** inwardly in the direction of arrow **176**, the body portion **162** deforms such that the electrical contact **168** bridges the switch contacts **104** and **106** on the second face surface **72** of the substrate **60** to thereby complete the circuit to which the switch contacts **104** and **106** are connected.

Referring to Figure **9**, the circuit carrier apparatus **52** is received in the cavity **126** such that the batteries **85** and **87** are positioned on opposite sides of the inner wall **124**. Potting material **190** is injected into the cavity to secure the circuit assembly therein and to fill all voids in the cavity to essentially make the housing body **120** and the circuit carrier apparatus **52** a unitary device.

Referring back to Figures **3** and **9**, the cover **56** has a mating face **192** that mates with an edge **194** of the housing body **120**. In addition, the cover **56** has a cavity **196** dimensioned to snugly receive the second end **68** of the circuit carrier apparatus **52** therein when the face **192** is placed in contact with the edge **194**. The cover **56** is then laser welded to the housing body **120** to form a unitary pressure sensing device as shown at **10** in Figure **1**. The cover **56** thus covers the antenna portion and is sealingly engaged with the housing **54** to prevent ingress and/or egress of fluid relative to the cavity **126** in the housing and the cavity **196** in the cover **56**.

Still referring to Figure **3**, it will be appreciated that the inner wall **124** defines a first opening **200** into the pressure sensing chamber **130** and the outer wall **122** defines a second opening **202** of the pressure sensing chamber **130**. The second opening **202** is generally coaxial with the first opening **200** to permit the projection **16** on the pressure coupling **12** to be inserted into the first opening to extend through the pressure sensing chamber **130** such that a portion of the pressure coupler extends out of the second opening **202** as shown in Figures **1** and **2**.

-21-

In the embodiment shown, the portion that extends out of the second opening **202** is the threaded end **20** of the pressure coupling **12**. The threaded end emulates a valve stem and cooperates with air filling equipment such as an air hose at a service station, for example. This allows air to be admitted into the
5 tire without the requirement to remove the pressure sensor from the valve stem **17**, which greatly enhances the convenience of the apparatus.

First and second pairs **204** and **206** of O-ring seals are disposed on opposite sides of the opening **34** such that fluid in the opening **34** cannot flow out of the
10 inlet opening **14**. The housing **54** is dimensioned such that when the projection **16** is fully inserted into the pressure sensing chamber **130**, the opening **132** in the inner wall **124** is longitudinally aligned to communicate with an annular space **208** extending about the outer surface of the projection, adjacent the opening **34**. Referring to Figures **2** and **8**, fluid exiting the
15 opening **34** can enter the annular space **208** and move through the opening **132** in the inner wall **124** and into the pressure sensing opening **90** in the pressure sensor **86**, to cause fluid pressure at that opening to be the same as the fluid pressure in the system being measured, thereby enabling the pressure sensor **86** to sense fluid pressure in the system being measured.

20 The pressure coupling described and shown herein is only one of a plurality of different pressure coupling devices that may be used with the above described pressure sensor apparatus **11**. Referring to Figure **2**, the body **13** and projection **16** have a particular external profile comprised of a cylindrical wall having successive portions **210**, **212** and **214** of different diameters two
25 of which, **210** and **212**, have grooves for holding O-rings **204** and **206**, for example. This external profile is particularly well adapted to cooperate with the generally cylindrical inner wall **124** of the housing **120** of the pressure sensor apparatus **11**. In particular, the O-rings seal against the inner wall **124**
30 to provide the generally annular space **208** which is sealed off by the o-rings from ambient, but in communication with the opening **132** in the inner wall and in communication with the pressure sensor **86**, inside the housing **120**. The

-22-

portion **214** has a larger diameter than the other two portions **210** and **212**, and acts to align the projection **16** in the pressure sensing chamber formed by the inner wall **124**, to prevent off-axis movement of the pressure coupler relative to the pressure sensor apparatus **11**, which could otherwise occur due to the elastic nature of the O-rings.

While the pressure coupling described herein is one which is intended for use in monitoring tire pressure, for example, it will be appreciated that by maintaining the same or a similar outer wall profile, pressure couplers of different types having different ends but having the same wall profile as shown in Figure **2**, could be substituted for the pressure coupler described. Thus, for example, instead of the threaded end **20**, referring to Figure **10**, the pressure coupler might simply have a sealed stub end **220**, where the pressure sensor is not intended to be used on a system that requires the ability to admit fluid into or out of the pressurized system without removing the pressure sensor. The opposite end **222** may have a pipe thread **224**, for example. This type of coupler may be used to mount the pressure sensor apparatus **11** inside a vehicle wheel, for example.

Referring to Figure **11**, in another embodiment, the pressure coupler may have hose barbs **230** and **232** at opposite ends, replacing the threaded end (**20** in Figure **2**) and extending from the body **13**, for example, for connecting the pressure coupler to hoses or conduits in a pressurized system or, referring to Figure **12**, the pressure coupler may have pipe threads **240**, **242** at opposite ends. A pressure coupler of this type may be used to couple the pressure sensor apparatus **11** to an air brake system on a vehicle, for example, or to an air line of an air operated circuit breaker in a power station, for example.

Referring to Figure **13**, in another embodiment, the pressure coupler may have a pipe thread **244** at one end and a pvc pipe fitting **246** at an opposite end.

-23-

Referring to Figure 14, in another embodiment, the pressure coupler may simply have open ends, 250, 252, for example, and this may be used to allow a pressure sensor apparatus to be used to monitor ambient air pressure.

5

While specific embodiments of the invention have been described and illustrated, such embodiments should be considered illustrative of the invention only and not as limiting the invention as construed in accordance with the accompanying claims.

What is claimed is:

1. A method of producing a circuit carrier for mounting components of a pressure sensing circuit, the method comprising:

5

forming on a substrate a circuit portion and an antenna portion,

wherein forming said antenna portion comprises forming a radio frequency antenna on said antenna portion; and

10

wherein forming said circuit portion comprises:

15

causing at least one power supply mount for a power supply for the pressure sensing circuit to be formed at a side of said substrate such that the power supply projects outwardly from said substrate;

20

causing a pressure sensor mount to be formed on said substrate such that when a pressure sensor is mounted to said mount a flat surface about a sensor opening of the pressure sensor is generally parallel and spaced apart from a first surface of said substrate and is adjacent the power supply;

25

causing ancillary component mounts to be formed in said circuit portion, said ancillary component mounts being operable to facilitate mounting of ancillary components for effecting a transmitter function; and

30

-25-

causing circuit interconnections between said at least one power supply mount, said pressure sensor mount and said ancillary component mounts and said antenna to be formed on said substrate such that a pressure sensor mounted to said pressure sensor mount and ancillary components mounted to said ancillary component mounts and are operable to receive power from a power supply mounted to said power supply mount and such that when the pressure sensor and ancillary components receive power from the power supply the transmitter function is effected, the transmitter function being operable to produce a transmittable signal in response to a pressure signal received from the pressure sensor, the transmittable signal being operable to be radiated by said antenna, for wireless reception by a remote receiver.

2. The method of claim 1 wherein said power supply mount includes a battery mount.
3. The method of claim 2 wherein said battery mount includes first and second battery mounts on opposite sides of said substrate, said pressure sensor mount being located between said first and second battery mounts.
4. The method of claim 3 wherein said first and second battery mounts are operably configured to facilitate mounting of disk-shaped batteries such that axes of said disk shaped batteries are generally parallel to a top surface of said substrate.

-26-

- 5 5. The method of claim 1 wherein forming said circuit portion and said antenna portion comprises causing said circuit portion to be located on a first end of said substrate and causing said antenna portion to be located on a second end of said substrate.
6. The method of claim 5 wherein forming said antenna portion comprises forming a serpentine conductor on said second end of said substrate.
- 10 7. The method of claim 1 wherein causing said ancillary component mounts to be formed in said circuit portion comprises causing switch contacts to be formed on said substrate, for mounting a switch thereto, and wherein causing said circuit interconnections to be formed on said substrate comprises causing said circuit interconnections to connect
- 15 said switch contacts to at least one of said ancillary component mounts, said power supply mount and said pressure sensor mount.
8. The method of claim 7 wherein causing said switch contacts to be formed on said substrate comprises causing said switch contacts to be formed on a second surface of said substrate, wherein said second
- 20 surface is generally parallel and spaced apart from said first surface.
9. A method of producing a pressure sensor circuit assembly comprising installing a power supply on said power supply mount of the circuit carrier of claim 1, installing a pressure sensor on said pressure sensor
- 25 mount of the circuit carrier of claim 1 and, installing ancillary components on said ancillary component mounts of the circuit carrier of claim 1, such that said ancillary components are operable to effect the transmitter function.

-27-

- 10.** A method of housing the pressure sensor circuit assembly of claim **9**, the method comprising:

5 receiving said circuit portion in a cavity of a body having a wall defining a pressure sensing chamber such that said opening in said pressure sensor is aligned with an opening in said pressure sensing chamber; and

10 urging said substrate in a direction tending to press said flat surface of said pressure sensor against a seal between said flat surface and a portion of said wall defining said pressure sensing chamber, such that said sensor opening of the pressure sensor is in fluid communication with said opening in said pressure
15 sensing chamber and such that said seal prevents ambient pressure from interfering with communication of fluid between said sensor opening of the pressure sensor and said opening in said pressure sensing chamber.

20

- 11.** The method of claim **10** wherein receiving comprises aligning said sensor opening of the pressure sensor with said opening in said pressure sensing chamber.

25

- 12.** The method of claim **11** wherein aligning comprises guiding said circuit assembly into a position relative to said pressure chamber such that said sensor opening of the pressure sensor is aligned with said opening in said pressure sensing chamber.

30

- 13.** The method of claim **12** wherein guiding comprises confining lateral movement of said circuit assembly.

-28-

- 5
14. The method of claim 12 wherein guiding comprises guiding edges on opposite sides of said substrate to position said substrate relative to said pressure sensing chamber while said substrate is moved into said cavity.
- 15
15. The method of claim 10 wherein urging comprises applying a force to a second surface of said substrate, said second surface being opposite said first surface.
- 10
16. The method of claim 15 wherein applying said force comprises causing said second surface of said substrate to bear upon a support in said cavity.
- 15
17. The method of claim 16 wherein causing said second surface of said substrate to bear upon said support comprises causing said second surface to bear upon first and second spaced apart supports.
- 20
18. The method of claim 15 further comprising holding a switch actuator adjacent switch contacts formed on said substrate.
- 25
19. The method of claim 18 wherein holding comprises receiving said switch actuator in an opening in said wall.
- 30
20. The method of claim 19 wherein holding comprises fastening a holder to said wall such that a surface of said switch actuator is accessible from outside said body.
21. A circuit carrier apparatus for a fluid pressure sensor, the apparatus comprising:
- a substrate having first and second opposite edges, first and second opposite ends and first and second opposite facing surfaces;

a circuit portion on said first end and an antenna portion on said second end,

5 wherein said antenna portion comprises a radio frequency antenna; and

wherein said circuit portion comprises:

10 at least one power supply mount for a power supply for a pressure sensing circuit, said power supply mount being located at a side of said substrate and such that the power supply projects outwardly from said substrate;

15 a pressure sensor mount formed on said substrate such that when a pressure sensor is mounted to said mount, a flat surface about a sensor opening on the pressure sensor is generally parallel and spaced apart from the first opposite facing surface
20 and is adjacent the power supply;

25 ancillary component mounts formed in said circuit portion, said ancillary component mounts being operable to facilitate mounting of ancillary components for effecting a transmitter function; and

30 circuit interconnections between said at least one power supply mount, said pressure sensor mount and said ancillary component mounts and said antenna such that a pressure sensor mounted to

-30-

said pressure sensor mount and ancillary components mounted to said ancillary component mounts are operable to receive power from a power supply mounted to said power supply mount and such that when the pressure sensor and ancillary components receive power from the power supply a transmitter function is effected, the transmitter function being operable to produce a transmittable signal in response to a pressure signal received from the pressure sensor, the transmittable signal being operable to be radiated by said antenna, for wireless reception by a remote receiver.

5

10

15

22. The apparatus of claim **21** wherein said power supply mount includes a battery mount.

20

23. The apparatus of claim **22** wherein said battery mount includes first and second battery mounts on opposite sides of said substrate, said pressure sensor mount being located between said first and second battery mounts.

25

24. The apparatus of claim **23** wherein said first and second battery mounts are operably configured to facilitate mounting of disk-shaped batteries such that axes of said disk shaped batteries are generally parallel to a top surface of said substrate.

30

25. The apparatus of claim **21** wherein said antenna portion comprises a serpentine conductor on said second opposite end of said substrate.

-31-

- 5 **26.** The apparatus of claim **21** further comprising switch contacts formed on said substrate, for cooperating with a switch contactor, said switch contacts being connected by said circuit interconnections to at least one of said ancillary component mounts, said power supply mount and said pressure sensor mount.
- 27.** The apparatus of claim **26** wherein said switch contacts are formed on said second opposite facing surface of said substrate.
- 10 **28.** A pressure sensor circuit apparatus comprising the circuit carrier of claim **21** and further comprising:
- a power supply installed on said power supply mount;
- 15 a pressure sensor installed on said pressure sensor mount
- ancillary components installed on said ancillary component mounts, such that said ancillary components are operable to effect the transmitter function.
- 20 **29.** An apparatus for housing a pressure sensor circuit, the apparatus comprising:
- a body having:
- 25 an outer wall defining a cavity operably configured to hold a substrate carrying a pressure sensor having a pressure sensing opening;
- 30 an inner wall inside said cavity defining a pressure sensing chamber;

-32-

an opening in said inner wall;

a seal interface about said opening;

5 aligning means for aligning said pressure sensor opening with said opening in said inner wall to provide for communication of fluid between said pressure sensing chamber and said pressure sensing opening; and

10 urging means for urging said pressure sensor against a seal adjacent said seal interface, such that said pressure sensing opening is in fluid communication with said opening in said inner wall and such that the seal prevents ambient pressure from interfering with communication of
15 fluid between said pressure sensing opening and said opening in said inner wall.

20 **30.** The apparatus of claim **29** wherein said aligning means comprises guiding means for guiding said substrate into a position in which said pressure sensing opening is aligned with said opening in said inner wall.

25 **31.** The apparatus of claim **30** wherein said guiding means comprises stops operable to contact first and second sides of said substrate for confining lateral movement of said pressure sensor circuit.

30 **32.** The apparatus of claim **31** wherein said first and second sides of said substrate have first and second edges respectively, and wherein said stops include first and second stops operably configured to bear upon said first and second edges to laterally position said substrate relative to said inner wall.

-33-

- 5 **33.** The apparatus of claim **29** wherein said urging means comprises means for applying a force on a surface of said substrate.
- 34.** The apparatus of claim **33** wherein said means for applying a force comprises a support on said outer wall of said body and facing inside said cavity, wherein said surface of said substrate bears upon said support.
- 10 **35.** The apparatus of claim **34** wherein said support comprises first and second spaced apart supports on said outer wall and facing into said cavity, wherein said surface of said substrate bears upon said first and second supports.
- 15 **36.** The apparatus of claim **29** further comprising holding means for holding a switch actuator in said outer wall such that the switch actuator is operable to make contact with switch contacts formed on said surface of said substrate.
- 20 **37.** The apparatus of claim **36** wherein said holding means includes a switch opening and wherein said switch opening is operable to receive the switch actuator.
- 25 **38.** The apparatus of claim **37** wherein said holding means further comprises a flat member having an opening permitting access to a surface of said switch actuator said flat member being fastened to said body such that said switch actuator provides a seal to prevent ingress and egress of fluid relative to said cavity through said switch actuator opening.
- 30 **39.** A pressure sensor apparatus comprising:
- a) a circuit carrier apparatus comprising:

-34-

a substrate having first and second opposite edges, first and second opposite ends and first and second opposite facing surfaces;

5

a circuit portion on said first opposite end and an antenna portion on said second opposite end,

10

wherein said antenna portion comprises a radio frequency antenna; and

wherein said circuit portion comprises:

15

at least one power supply located at a side of said substrate and such that the power supply projects outwardly from said substrate;

20

a pressure sensor having a flat surface and a pressure sensor opening on said flat surface, said flat surface being generally parallel and spaced apart from the first opposite facing surface and adjacent the power supply;

25

a transmitter connected to said pressure sensor and said antenna for producing a signal for radiation by said antenna in response to a sense signal produced by said pressure sensor;

30

b) a housing for housing said circuit carrier apparatus, said housing comprising:

a body having:

-35-

an outer wall defining a cavity operably configured to hold the circuit portion of said substrate;

5 an inner wall inside said cavity defining a pressure sensing chamber;

an opening in said inner wall;

10 a seal about said opening in said inner wall;

aligning means for aligning said pressure sensor opening with said opening in said inner wall to provide for communication of fluid between said pressure sensing chamber and said pressure sensor opening; and

15

urging means for urging said pressure sensor against said seal, such that said pressure sensor opening is in fluid communication with said opening in said inner wall and such that said seal prevents ambient pressure from interfering with communication of fluid between said opening in said pressure sensor opening and said opening in said inner wall;

20

25

potting material in said cavity and about said circuit portion for securing said substrate in said cavity; and

30 a cover for covering said antenna portion, said cover being sealingly engaged with said housing to prevent ingress and egress of fluid relative to said cavity.

- 5 **40.** The apparatus of claim **39** wherein said inner wall defines a first opening into said pressure sensing chamber, said first opening being operable to receive a pressure coupling for coupling fluid pressure from a pressurized system to said pressure sensing chamber.
- 10 **41.** The apparatus of claim **40** wherein said outer wall defines a second opening into said pressure sensing chamber, said second opening being generally coaxial with said first opening to permit a projection on said pressure coupling to be inserted into said first opening to extend through said pressure sensing chamber such that a portion of said pressure coupling extends out of said second opening.
- 15 **42.** The apparatus of claim **41** wherein said aligning means comprises guiding means for guiding said substrate into said a position in which said pressure sensor opening is aligned with said opening in said inner wall.
- 20 **43.** The apparatus of claim **42** wherein said guiding means comprises stops operable to contact said first and second sides of said substrate for confining lateral movement of said circuit assembly.
- 25 **44.** The apparatus of claim **42** wherein said first and second sides of said substrate have first and second edges respectively, and wherein said stops include first and second stops operably configured to bear said first and second edges to laterally position said substrate relative to said inner wall.
- 30 **45.** The apparatus of claim **41** wherein said urging means comprises means for applying a force to said second opposite surface of said substrate.

-37-

- 5
46. The apparatus of claim 45 wherein said means for applying a force comprises a support on said outer wall of said body, said support facing inside said cavity, said second opposite facing surface of said substrate bearing upon said support.
- 10
47. The apparatus of claim 46 wherein said support comprises first and second spaced apart supports on said outer wall and facing into said cavity, wherein said second opposite facing surface of said substrate bears upon said support.
- 15
48. The apparatus of claim 46 wherein said circuit portion comprises switch contacts formed on said second opposite facing surface of said substrate, said switch contacts being operably connected to said pressure sensor and wherein said apparatus further comprises a switch actuator and holding means for holding said switch actuator in said outer wall such that said switch actuator is operable to make contact with said switch contacts.
- 20
49. The apparatus of claim 48 wherein said holding means includes a switch opening operably configured to hold said switch actuator.
- 25
50. The apparatus of claim 49 wherein said holding means further comprises a flat member having an opening permitting access to a surface of said switch actuator, said flat member being fastened to said body such that said switch actuator provides a sealing function to prevent ingress and egress of fluid relative to said cavity through said opening.
- 30
51. A pressure sensing system comprising the pressure sensor apparatus of claim 39 and a pressure coupler operably configured to communicate with said pressure sensing chamber to communicate fluid pressure to said pressure sensor.

-38-

52. The pressure sensing system of claim 51 wherein said pressure coupler comprises a projection having an inlet opening operably configured to communicate with a pressurized system to receive pressurized fluid therefrom, and wherein said projection and said pressure sensing chamber are operably configured such that said projection is sealingly received in said pressure sensing chamber and such that fluid entering said inlet opening is communicated to said pressure sensor through said pressure sensing chamber.

5

10

+

1/12

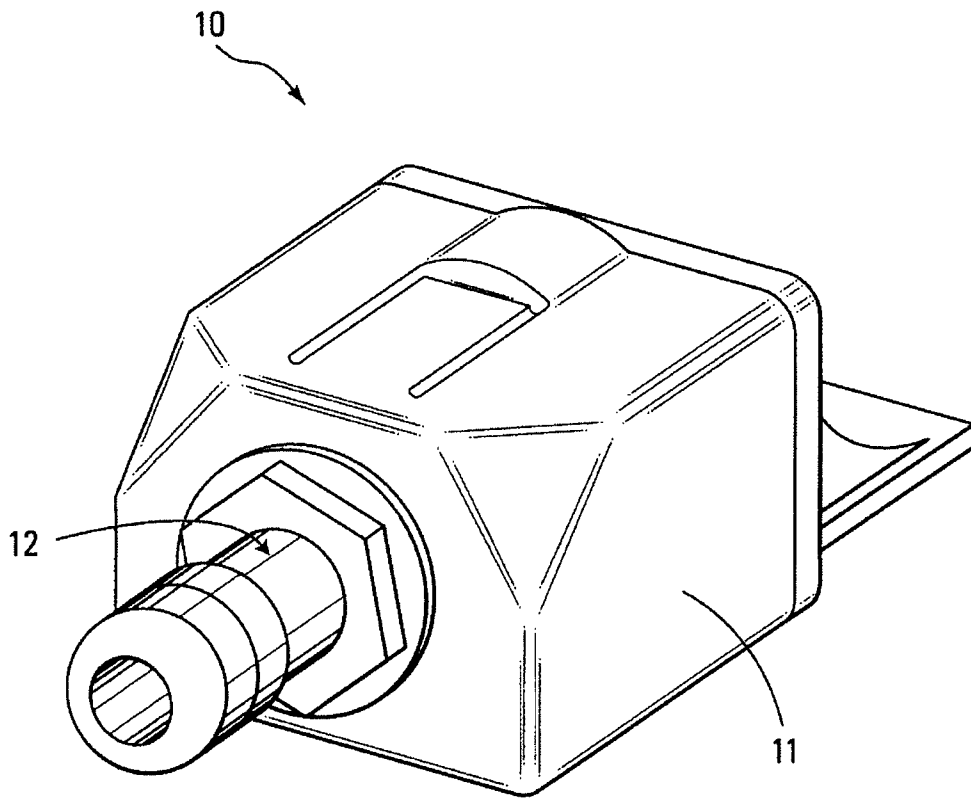

FIG. 1

+

+

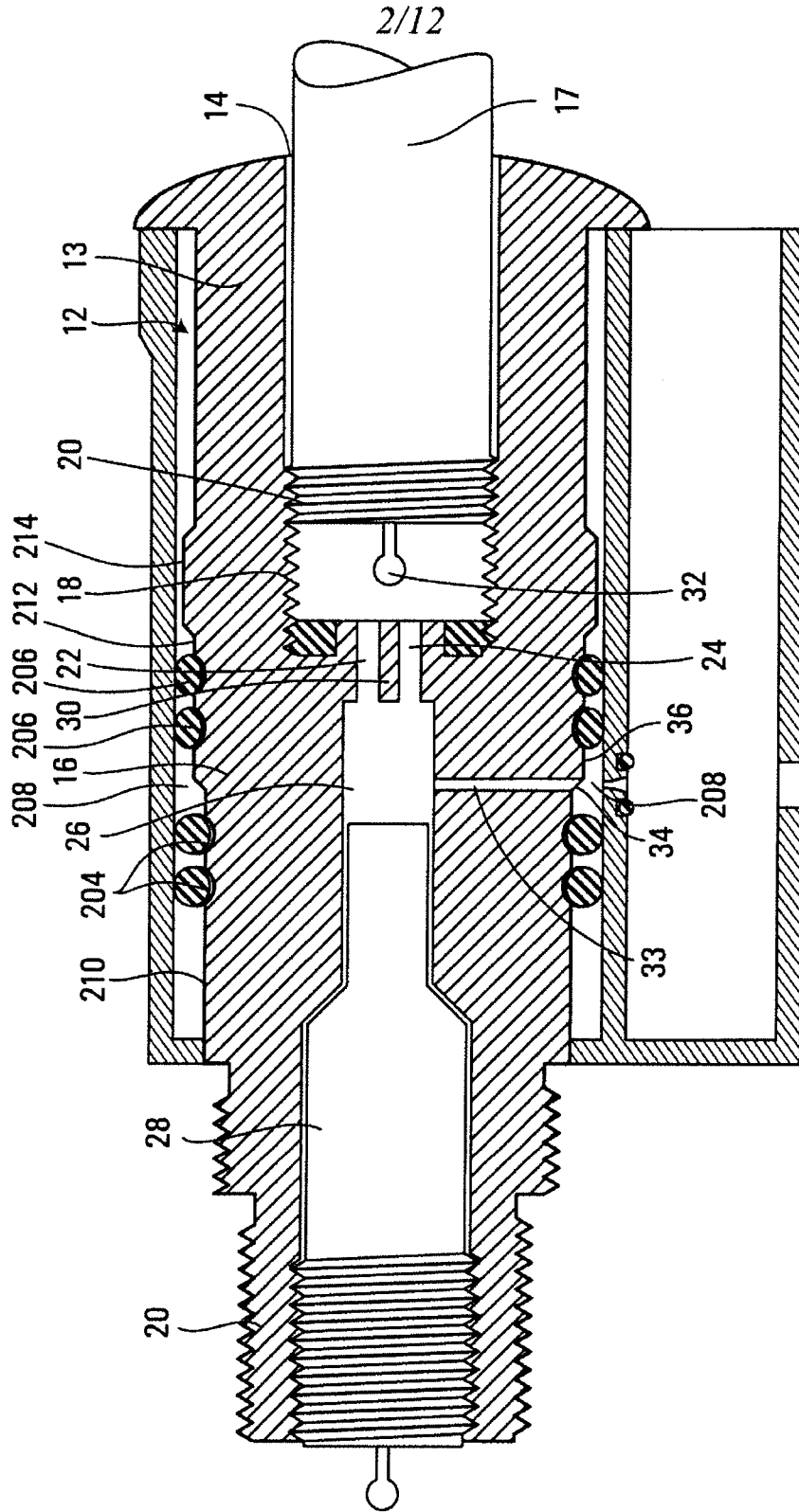

FIG. 2

+

+

3/12

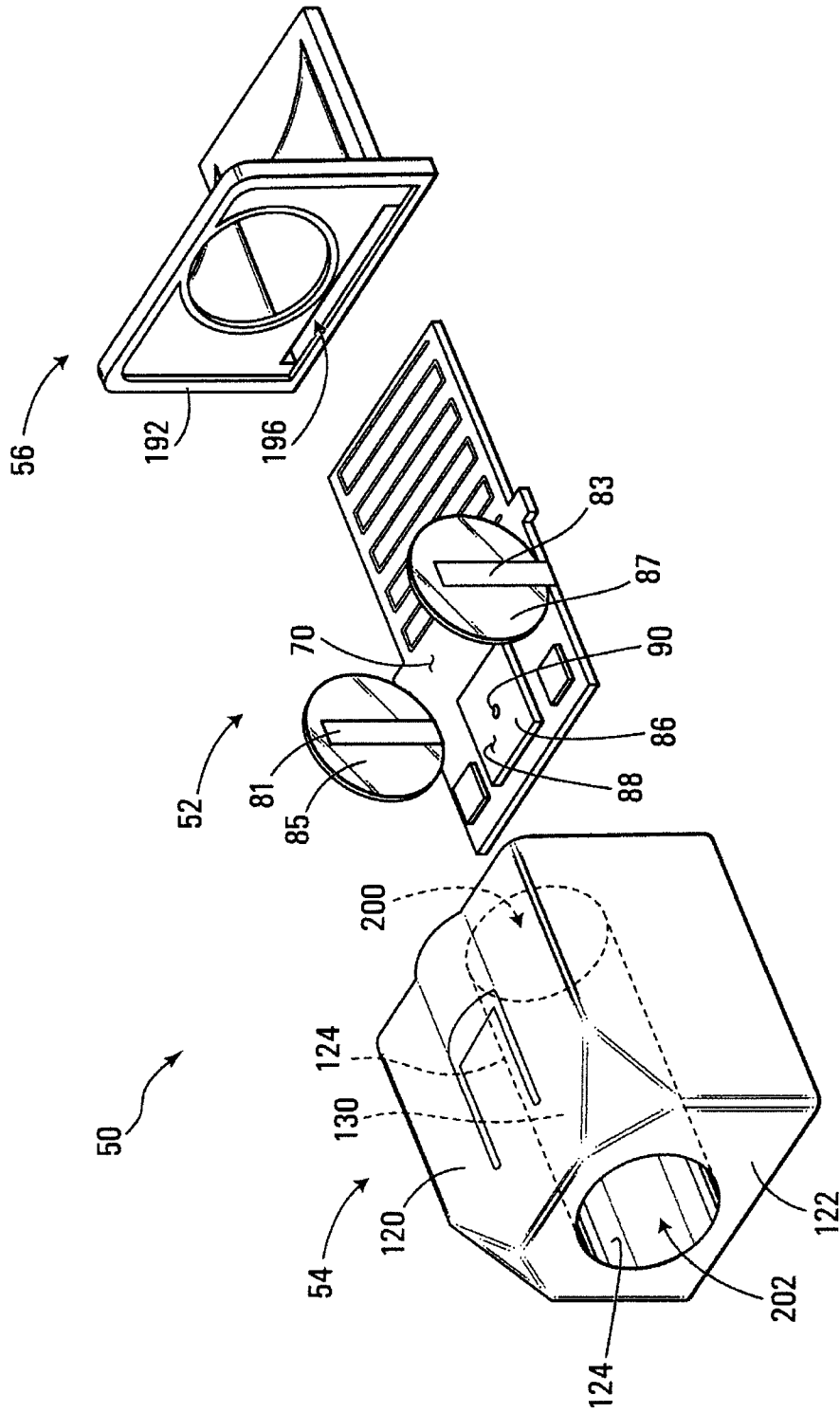

FIG. 3

+

+

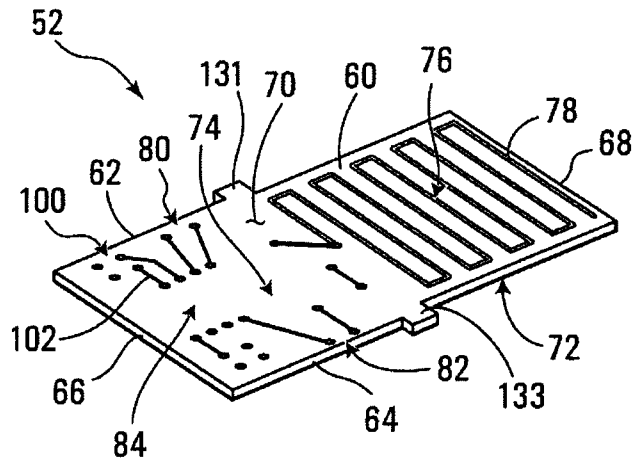

FIG. 4

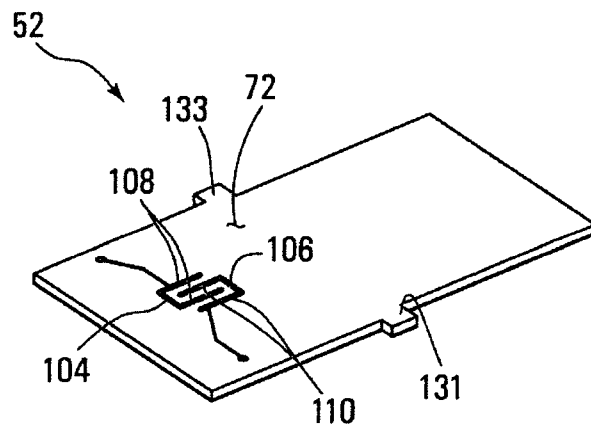

FIG. 5

+

+

5/12

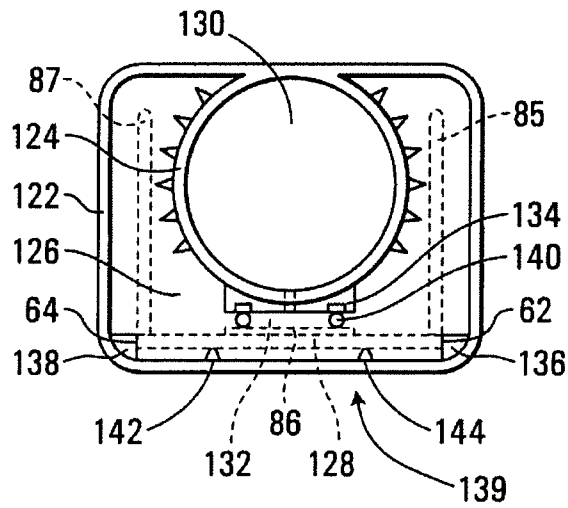

FIG. 6

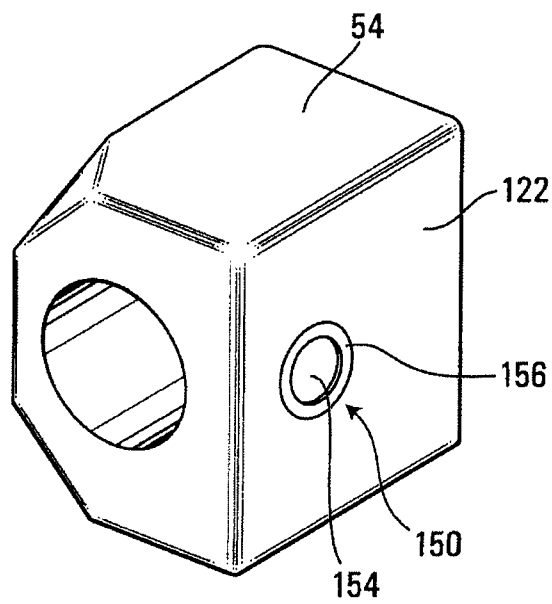

FIG. 7

+

+

6/12

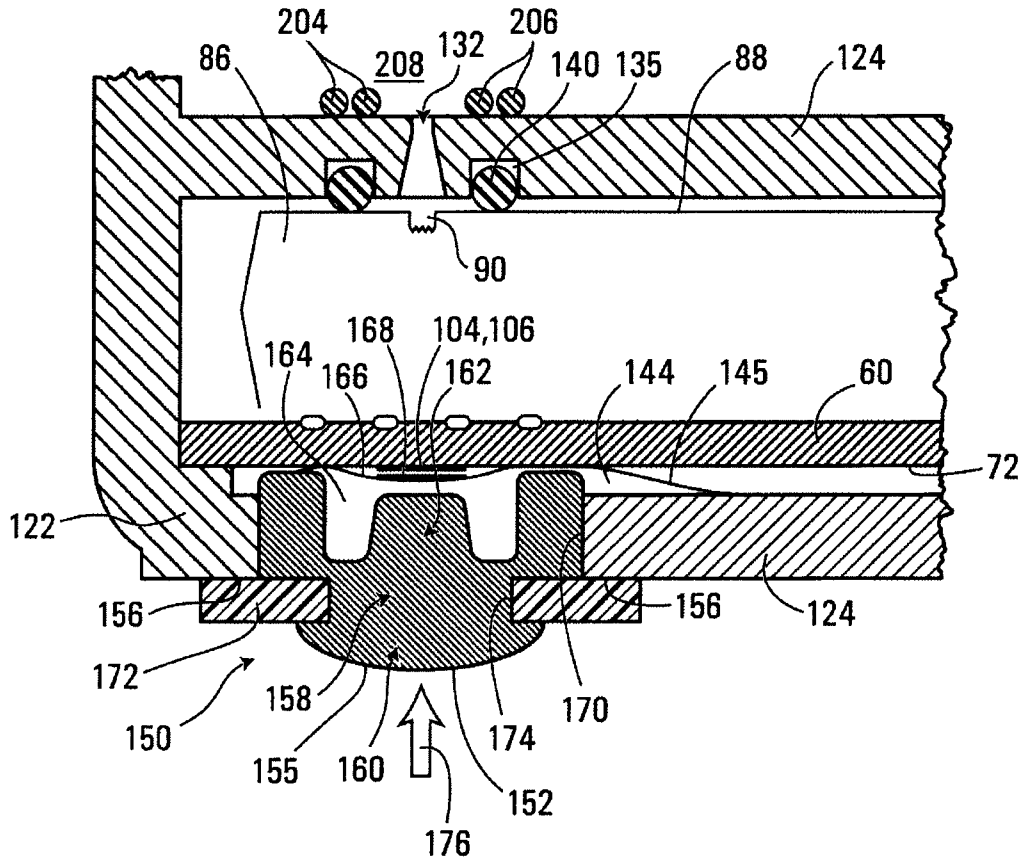

FIG. 8

+

+

7/12

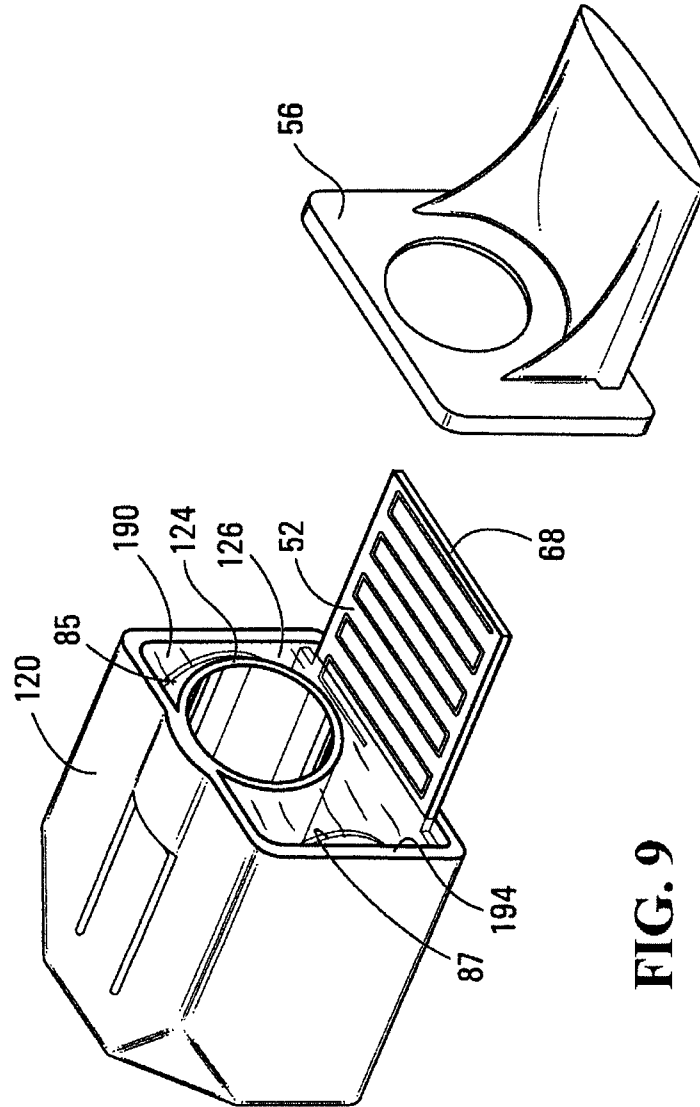

FIG. 9

+

+

8/12

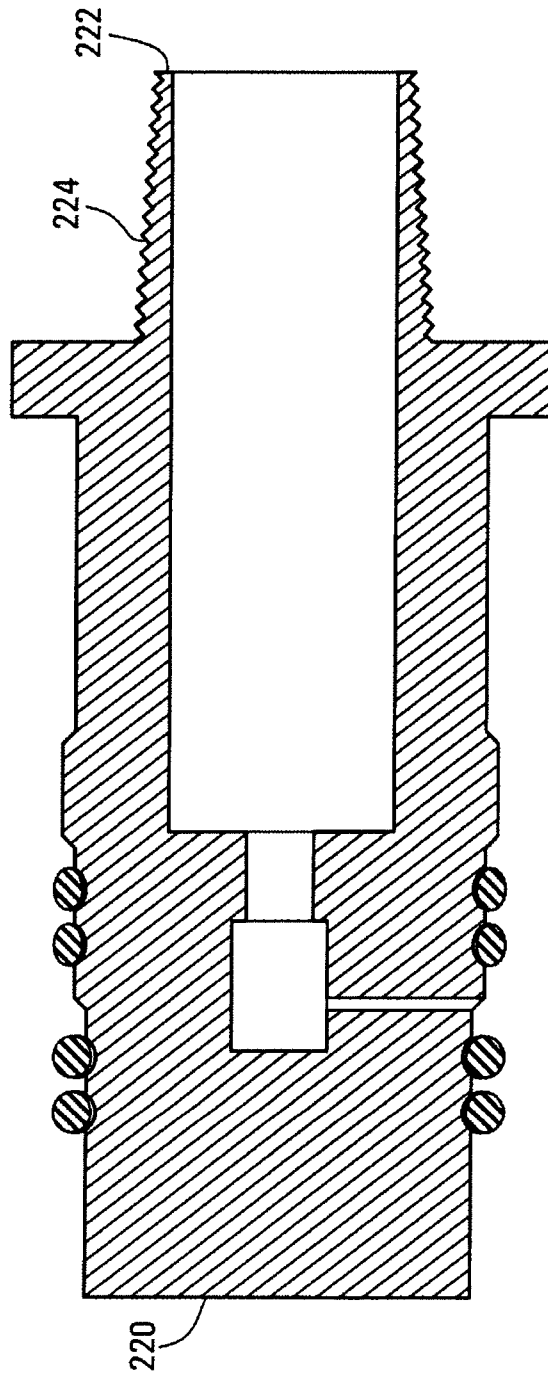

FIG. 10

+

+

9/12

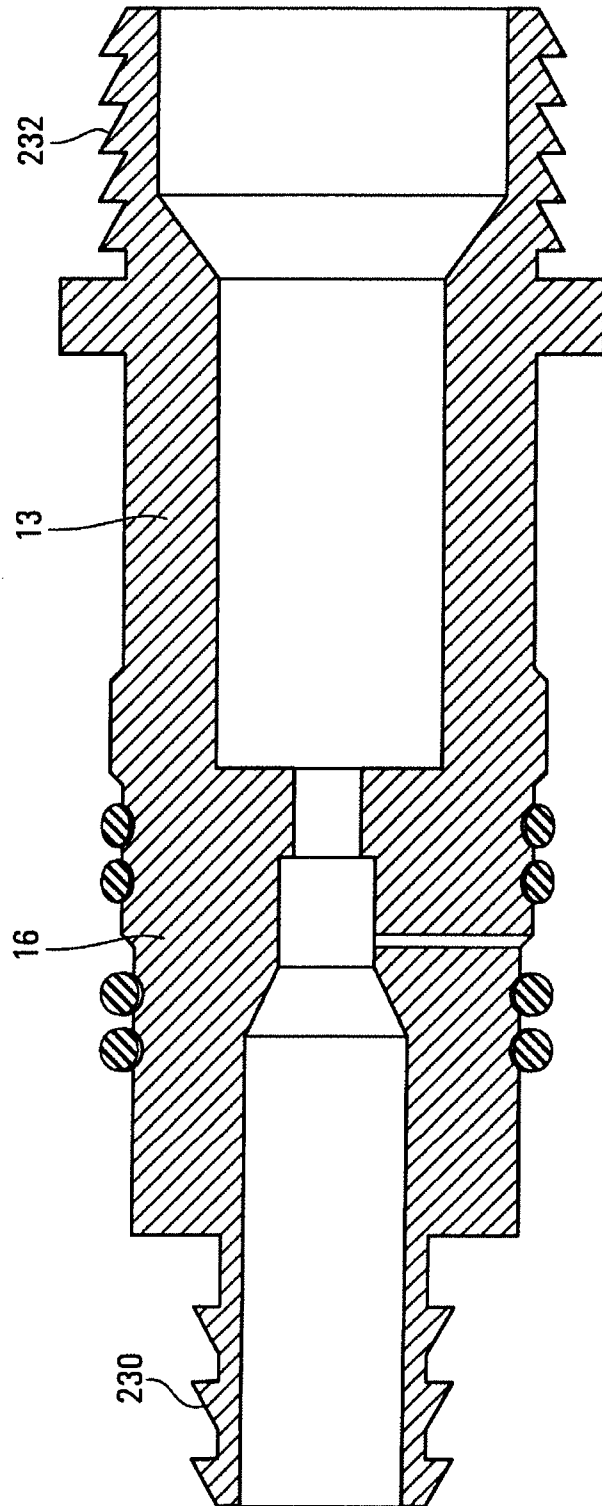

FIG. 11

+

+

10/12

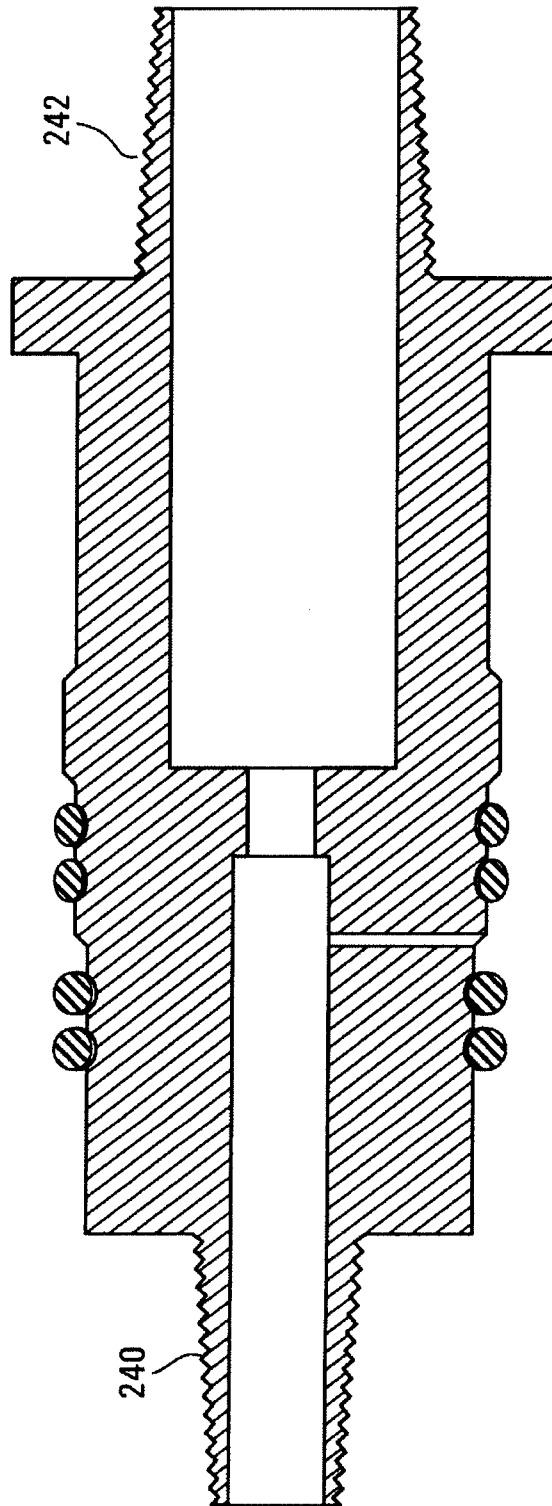

FIG. 12

+

+

11/12

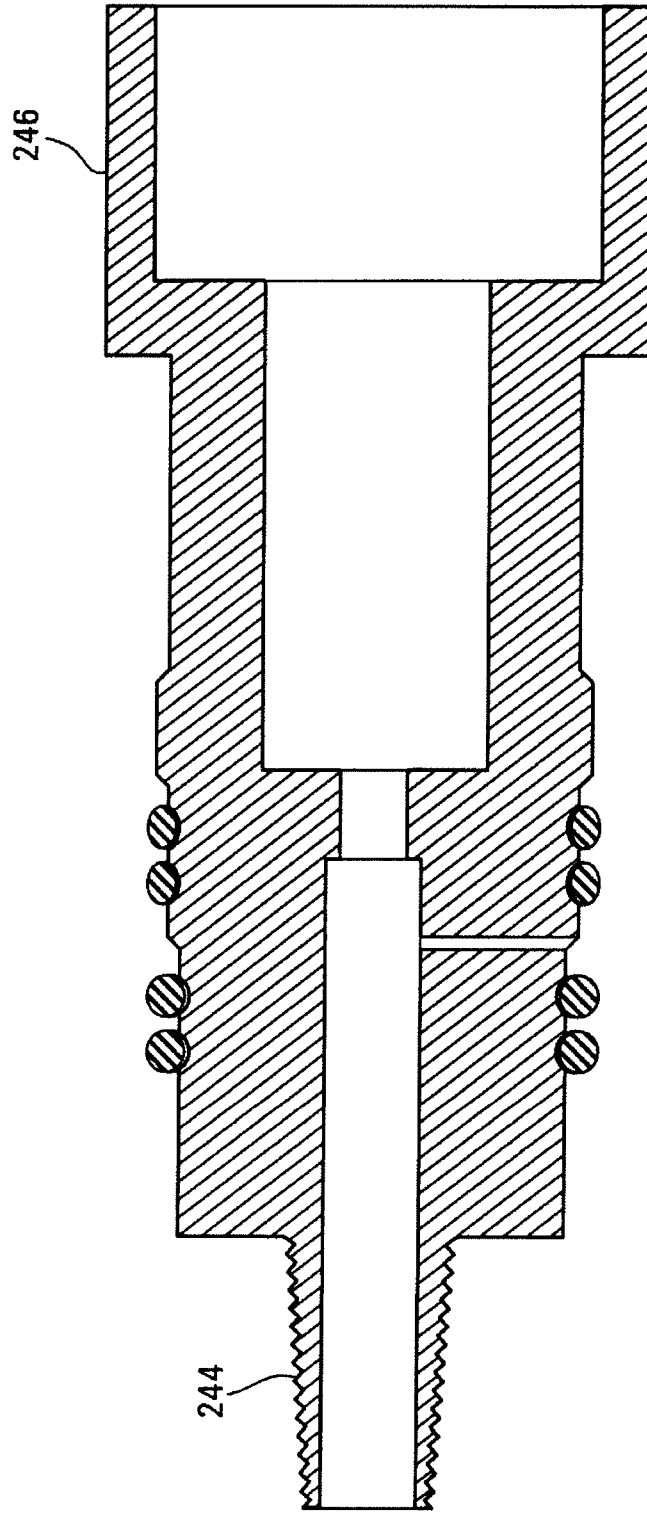

FIG. 13

+

+

12/12

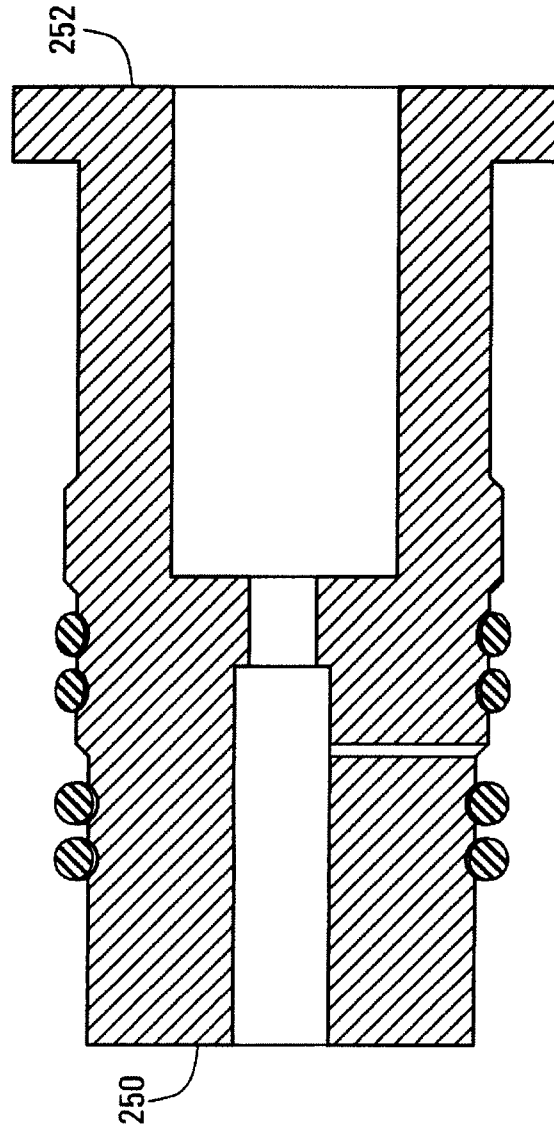

FIG. 14

+

INTERNATIONAL SEARCH REPORT

International application No.
PCT/CA2007/001811

<p>A. CLASSIFICATION OF SUBJECT MATTER IPC: G01L 19/08 (2006.01), G01L 19/14 (2006.01), G01L 19/00 (2006.01) According to International Patent Classification (IPC) or to both national classification and IPC</p>																	
<p>B. FIELDS SEARCHED</p> <p>Minimum documentation searched (classification system followed by classification symbols) IPC: G01L (2006.01); US classes: 73/146, 340/438, 340/441, 340/447 in combination with keywords</p> <p>Documentation searched other than minimum documentation to the extent that such documents are included in the fields searched</p> <p>Electronic database(s) consulted during the international search (name of database(s) and, where practicable, search terms used) Canadian Patent Database, USPTO West, Delphion. Keywords: pressure sensor, pressure transducer, substrate, circuit board, power supply, antenna, tire, tyre, housing, valve stem</p>																	
<p>C. DOCUMENTS CONSIDERED TO BE RELEVANT</p> <table border="1"> <thead> <tr> <th>Category*</th> <th>Citation of document, with indication, where appropriate, of the relevant passages</th> <th>Relevant to claim No.</th> </tr> </thead> <tbody> <tr> <td>A</td> <td>US2004/0055371 A1 (Sanchez et al.) 25 March 2004 (25-03-2004) * Para. 0018-0031; Fig. 1-7 *</td> <td>1-6, 9, 14, 21-25, 28-35, 39-47, 51, 52</td> </tr> <tr> <td>A</td> <td>US7116217 B2 (Okubo) 3 October 2006 (03-10-2006) * Col. 1, lines 25-34; col. 3, lines 9-51; Fig. 2 *</td> <td>1-4, 29-31, 39, 51, 52</td> </tr> <tr> <td>A</td> <td>US6799455 B1 (Neefeldt et al.) 5 October 2004 (05-10-2004) * Col. 1, line 66 to col. 2, line 8; col. 3, line 65 to col. 5, line 48; Fig. 3, 5 *</td> <td>1-4, 29-31, 29, 51, 52</td> </tr> <tr> <td>A</td> <td>US2006/0061463 A1 (Wilson, II) 23 March 2006 (23-03-2006) * Para 9, 11-14, 26-30, 36, 39, 49, 54-59; Fig. 2, 4, 5 *</td> <td>1-5, 9-17, 21-24, 28-35, 39, 51, 52</td> </tr> </tbody> </table>			Category*	Citation of document, with indication, where appropriate, of the relevant passages	Relevant to claim No.	A	US2004/0055371 A1 (Sanchez et al.) 25 March 2004 (25-03-2004) * Para. 0018-0031; Fig. 1-7 *	1-6, 9, 14, 21-25, 28-35, 39-47, 51, 52	A	US7116217 B2 (Okubo) 3 October 2006 (03-10-2006) * Col. 1, lines 25-34; col. 3, lines 9-51; Fig. 2 *	1-4, 29-31, 39, 51, 52	A	US6799455 B1 (Neefeldt et al.) 5 October 2004 (05-10-2004) * Col. 1, line 66 to col. 2, line 8; col. 3, line 65 to col. 5, line 48; Fig. 3, 5 *	1-4, 29-31, 29, 51, 52	A	US2006/0061463 A1 (Wilson, II) 23 March 2006 (23-03-2006) * Para 9, 11-14, 26-30, 36, 39, 49, 54-59; Fig. 2, 4, 5 *	1-5, 9-17, 21-24, 28-35, 39, 51, 52
Category*	Citation of document, with indication, where appropriate, of the relevant passages	Relevant to claim No.															
A	US2004/0055371 A1 (Sanchez et al.) 25 March 2004 (25-03-2004) * Para. 0018-0031; Fig. 1-7 *	1-6, 9, 14, 21-25, 28-35, 39-47, 51, 52															
A	US7116217 B2 (Okubo) 3 October 2006 (03-10-2006) * Col. 1, lines 25-34; col. 3, lines 9-51; Fig. 2 *	1-4, 29-31, 39, 51, 52															
A	US6799455 B1 (Neefeldt et al.) 5 October 2004 (05-10-2004) * Col. 1, line 66 to col. 2, line 8; col. 3, line 65 to col. 5, line 48; Fig. 3, 5 *	1-4, 29-31, 29, 51, 52															
A	US2006/0061463 A1 (Wilson, II) 23 March 2006 (23-03-2006) * Para 9, 11-14, 26-30, 36, 39, 49, 54-59; Fig. 2, 4, 5 *	1-5, 9-17, 21-24, 28-35, 39, 51, 52															
<p><input type="checkbox"/> Further documents are listed in the continuation of Box C. <input checked="" type="checkbox"/> See patent family annex.</p>																	
<table border="0"> <tr> <td>* Special categories of cited documents :</td> <td>"T" later document published after the international filing date or priority date and not in conflict with the application but cited to understand the principle or theory underlying the invention</td> </tr> <tr> <td>"A" document defining the general state of the art which is not considered to be of particular relevance</td> <td>"X" document of particular relevance; the claimed invention cannot be considered novel or cannot be considered to involve an inventive step when the document is taken alone</td> </tr> <tr> <td>"E" earlier application or patent but published on or after the international filing date</td> <td>"Y" document of particular relevance; the claimed invention cannot be considered to involve an inventive step when the document is combined with one or more other such documents, such combination being obvious to a person skilled in the art</td> </tr> <tr> <td>"L" document which may throw doubts on priority claim(s) or which is cited to establish the publication date of another citation or other special reason (as specified)</td> <td>"&" document member of the same patent family</td> </tr> <tr> <td>"O" document referring to an oral disclosure, use, exhibition or other means</td> <td></td> </tr> <tr> <td>"P" document published prior to the international filing date but later than the priority date claimed</td> <td></td> </tr> </table>			* Special categories of cited documents :	"T" later document published after the international filing date or priority date and not in conflict with the application but cited to understand the principle or theory underlying the invention	"A" document defining the general state of the art which is not considered to be of particular relevance	"X" document of particular relevance; the claimed invention cannot be considered novel or cannot be considered to involve an inventive step when the document is taken alone	"E" earlier application or patent but published on or after the international filing date	"Y" document of particular relevance; the claimed invention cannot be considered to involve an inventive step when the document is combined with one or more other such documents, such combination being obvious to a person skilled in the art	"L" document which may throw doubts on priority claim(s) or which is cited to establish the publication date of another citation or other special reason (as specified)	"&" document member of the same patent family	"O" document referring to an oral disclosure, use, exhibition or other means		"P" document published prior to the international filing date but later than the priority date claimed				
* Special categories of cited documents :	"T" later document published after the international filing date or priority date and not in conflict with the application but cited to understand the principle or theory underlying the invention																
"A" document defining the general state of the art which is not considered to be of particular relevance	"X" document of particular relevance; the claimed invention cannot be considered novel or cannot be considered to involve an inventive step when the document is taken alone																
"E" earlier application or patent but published on or after the international filing date	"Y" document of particular relevance; the claimed invention cannot be considered to involve an inventive step when the document is combined with one or more other such documents, such combination being obvious to a person skilled in the art																
"L" document which may throw doubts on priority claim(s) or which is cited to establish the publication date of another citation or other special reason (as specified)	"&" document member of the same patent family																
"O" document referring to an oral disclosure, use, exhibition or other means																	
"P" document published prior to the international filing date but later than the priority date claimed																	
Date of the actual completion of the international search 13 December 2007 (13-12-2007)		Date of mailing of the international search report 17 January 2008 (17-01-2008)															
Name and mailing address of the ISA/CA Canadian Intellectual Property Office Place du Portage I, C114 - 1st Floor, Box PCT 50 Victoria Street Gatineau, Quebec K1A 0C9 Facsimile No.: 001-819-953-2476		Authorized officer Arthur Smith 819-953-1360															

INTERNATIONAL SEARCH REPORT
Information on patent family members

International application No.
PCT/CA2007/001811

Patent Document Cited in Search Report	Publication Date	Patent Family Member(s)	Publication Date
US7116217	03-10-2006	DE602004000742D D1 EP1500528 A1 JP2005043282 A	01-06-2006 26-01-2005 17-02-2005
US2004055371	25-03-2004	NONE	
US6799455	05-10-2004	NONE	
US2006061463	23-03-2006	NONE	