

W. S. CRAIG.
 PORTABLE JIB CRANE.
 APPLICATION FILED SEPT. 3, 1910.

998,469.

Patented July 18, 1911.

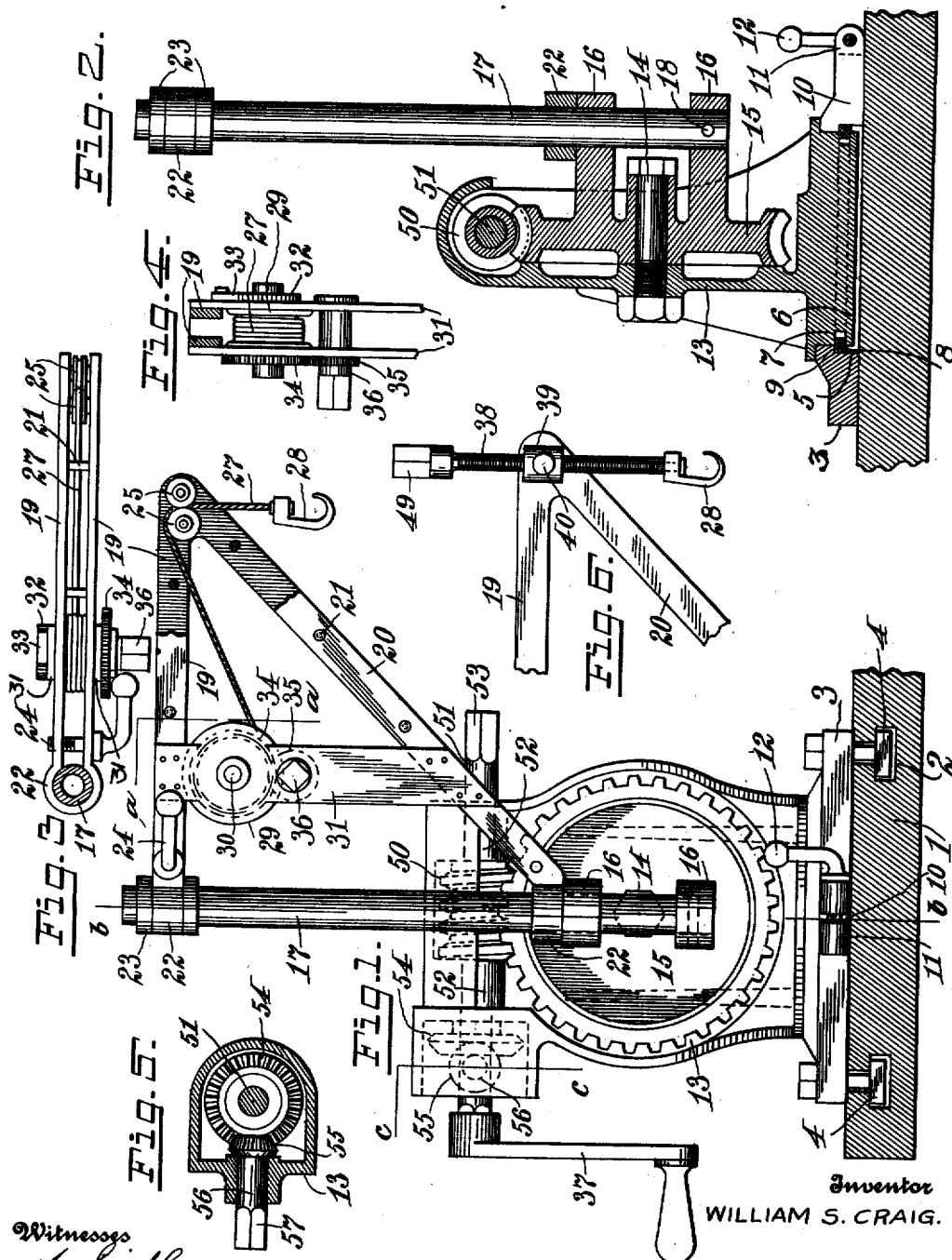

Witnesses
 W. Subler
 H. J. Smith

Inventor
 WILLIAM S. CRAIG.

R. J. McCarty
 his. Attorney

UNITED STATES PATENT OFFICE.

WILLIAM S. CRAIG, OF ST. MARYS, OHIO, ASSIGNOR OF ONE-HALF TO CHRISTIAN W. SCHMEHL, OF ST. MARYS, OHIO.

PORTABLE JIB-CRANE.

998,469.

Specification of Letters Patent. Patented July 18, 1911.

Application filed September 3, 1910. Serial No. 580,321.

To all whom it may concern:

Be it known that I, WILLIAM S. CRAIG, a citizen of the United States, residing at St. Marys, in the county of Auglaize and State of Ohio, have invented certain new and useful Improvements in Portable Jib-Cranes; and I do declare the following to be a full, clear, and exact description of the invention, such as will enable others skilled in the art to which it appertains to make and use the same, reference being had to the accompanying drawings, and to the letters and figures of reference marked thereon, which form a part of this specification.

This invention relates to new and useful improvements in portable jib cranes.

The object of the invention is to provide a device of the above type which is light in weight, of great strength and of simple construction, and which may be placed on a machine tool such as planers, shapers, milling-machines, lathes etc. and used to hoist the face plates and chucks to position and the work to a position to be operated upon by the tool.

Referring to the drawings, Figure 1 is a side elevation of the device attached to a portion of the machine tool; Fig. 2 is a section on the line *b b* of Fig. 1; Fig. 3 is a top plan view of the jib; Fig. 4 is a section on the line *a a* of Fig. 1; Fig. 5 is a section on the line *c c* of Fig. 1; and Fig. 6 is a view of a modified form of mechanism.

Referring more particularly to the drawings, 1 represents a plate portion of a machine tool provided with T slots 2. Mounted on the plate 1 is a base member 3 attached thereto by a suitable number of T bolts 4 which enter the T slots 2. The base member 3 is provided with a central opening 5 in which a pivot member 6 is adapted to rest. To maintain the pivot member 6 in position, said member is provided with a recess 7 which receives a resilient ring 8, said ring being adapted to engage a shoulder 9 of the base member 3. To secure the pivot member 6 in position, the base member 3 is provided with a clamp which consists of a kerf 10, lugs 11 and a hand screw 12 which passes through the lugs 11. Mounted upon the pivot member 6 is a standard or housing 13 supporting a pivot 14 on which a worm gear 15 is adapted to oscillate. The gear 15 is provided with lugs 16 which support a tubular post 17, said

post being attached to one of the lugs by means of a pin 18. The post 17 supports a jib which consists of upper horizontal members 19 and brace members 20; both members consisting of right and left portions separated by stays 21. The right and left members pass around the post 17 and form upper and lower loops 22, thereby allowing the jib to swing on the post, the upper loop lying between collars 23 and the lower loop resting against the upper lug 16. To clamp the jib in position, the right and left members of the horizontal portion 19 are provided with a hand screw 24 which is adapted to tighten the upper loop 22 around the post. The jib thus constructed may be provided with a windlass constructed as follows. Mounted at the outer end and between the right and left portions of the jib are sheaves 25 between which a cable 27 passes. The outer end of the cable is provided with a hook 28 and the inner end passes around, and is attached to, a drum 29. The drum 29 is mounted on a shaft 30 journaled in plates 31 attached to the jib. On one end of the shaft 30 is mounted a ratchet 32 adapted to be engaged by a pawl 33 to lock the drum 29 in position; and the other end of the shaft is provided with a gear 34 in mesh with a pinion 35. The pinion 35 is on a shaft 36, one end of which is adapted to receive an interchangeable crank 37, shown in Fig. 1. It will thus be seen that the hook 28 may be elevated or lowered by means of the crank in a well known manner. In lieu of the above described windlass, the construction shown in Fig. 6 may be adopted. In this construction the hook 28 is attached to the lower end of a screw 38 which passes through a nut 39 provided with trunnions 40 journaled in the jib. The upper end of the screw 38 is provided with a square portion 49 adapted to receive the crank 37. By rotating the screw 38, the hook 28 and the load carried thereby, may be elevated or lowered.

In addition to elevating and lowering the load by the windlass or screw, the load may be elevated or lowered by swinging the jib on the pivot 14 as follows. The gear 15 meshes with a worm 50 mounted on a shaft 51 journaled in bearings 52 and provided with square portions 53 adapted to receive the crank 37. It will be seen that if the worm 50 and the gear 15 are rotated in one

direction, the jib, the hook and the work to which it is attached, will be lowered; and if the worm and gear are rotated in the opposite direction, the jib and the work carried thereby will be elevated. To secure a greater lifting effort than is possible by attaching the crank 37 to the shaft 51, the shaft 51 is provided with a bevel gear 54 which meshes with a smaller bevel gear 55 mounted on, or a part of, a stub shaft 56, said shaft having bearing in the standard or housing 13, and provided with a square portion 57 adapted to receive the crank 37. The device as thus constructed is of great strength and is capable of lifting a weight many times greater than its own. It may therefore be placed on a machine tool by a single person, and set in position a piece of work the weight of which, under other circumstances, would require assistance.

Without limiting myself to the precise form and arrangement shown and described, I claim:

1. In a device of the type specified, the combination of a support, a gear mounted on said support, a jib mounted on said gear and adapted to engage a piece of work, and a worm adapted to rock said gear whereby

the jib and work carried thereby, are elevated and lowered. 30

2. In a device of the type specified, the combination of a base-plate, a support pivotally attached to said plate, a gear pivoted on said support, a jib mounted on said gear, and a worm adapted to rock said gear to elevate and lower said jib. 35

3. In a device of the type specified, the combination of a supporting member, a gear pivoted on said supporting member, a jib mounted on said gear, a worm in mesh with said gear, a shaft on which said worm is mounted, a bevel gear on said shaft, and a smaller bevel gear in mesh with said larger bevel gear whereby said jib may be elevated or lowered. 45

4. In a device of the type specified, the combination of a supporting member, a jib pivotally mounted thereon, a windlass-mounted on said jib and means for rocking said jib. 50

In testimony whereof I affix my signature, in presence of two witnesses.

WILLIAM S. CRAIG.

Witnesses:

GEORGE MEYERS,
JACOB T. KOENIG.