

(No Model.)

T. D. NOONE.
CATERPILLAR TRAP.

No. 523,682.

Patented July 31, 1894.

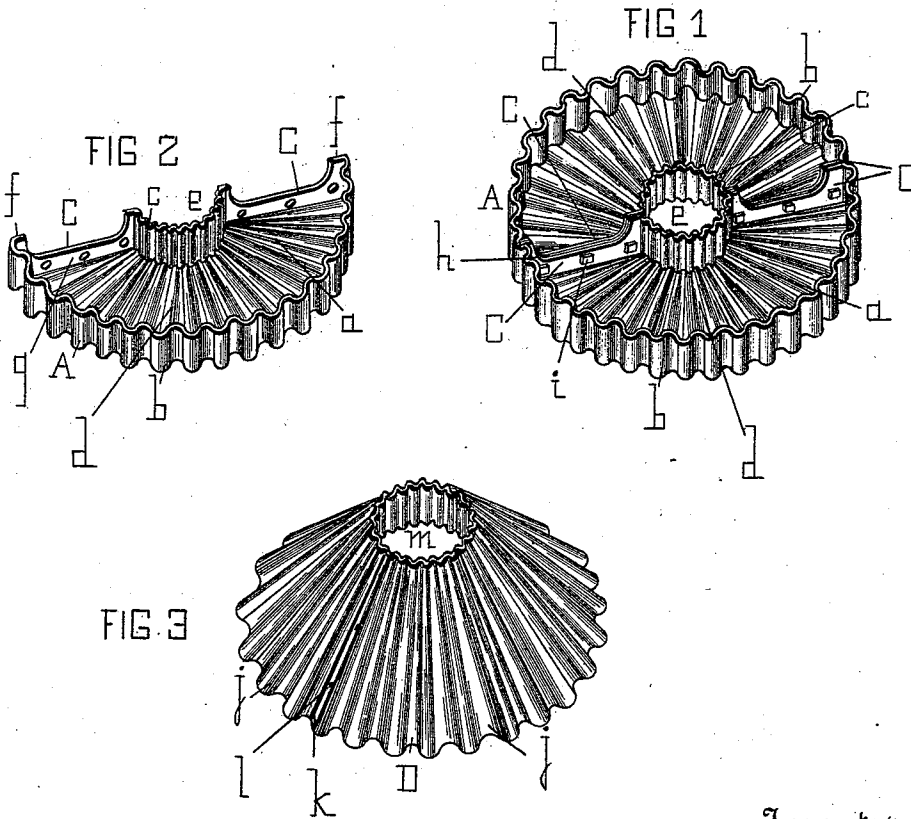
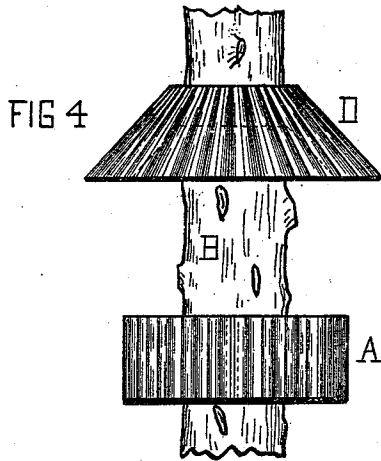

Witnesses
John H. Sample
Wm. A. Hoffmann

Inventor
Thomas D. Noone
by Francis D. Pastorius.
Attorney

UNITED STATES PATENT OFFICE.

THOMAS D. NOONE, OF CAMDEN, NEW JERSEY.

CATERPILLAR-TRAP.

SPECIFICATION forming part of Letters Patent No. 523,682, dated July 31, 1894.

Application filed March 13, 1894. Serial No. 503,449. (No model.)

To all whom it may concern:

Be it known that I, THOMAS D. NOONE, a citizen of the United States, residing at Camden, in the county of Camden and State of New Jersey, have invented certain new and useful Improvements in Caterpillar-Traps; and I do declare the following to be a full, clear, and exact description of the invention, such as will enable others skilled in the art to which it appertains to make and use the same, reference being had to the accompanying drawings, and to the letters of reference marked thereon, which form a part of this specification.

The invention is for preventing caterpillars from ascending the trunk of a tree, and is an improvement on the caterpillar-trap for which Letters Patent No. 505,226, were granted to me on the 19th day of September, 1893. The several parts composing the invention are corrugated to permit of the necessary spreading consequent upon the growth and increased diameter of the tree to which it may be applied.

It consists in a corrugated double-cylinder closed by a corrugated bottom so as to form an annular vessel capable of holding a sticky liquid, and a corrugated trunk-opening in the center, together with a corrugated shedder.

For facility in placing the corrugated-trap on a trunk of a tree, it is divided diametrically and the connecting edges provided with flanges the ends of which are higher than the middle. In practice the corrugated central-opening is brought together around the trunk, and after packing is placed between the flanges they are bolted together. The corrugated shedder is used to prevent rain from dropping into and diluting the sticky liquid which catches and destroys the caterpillars.

On reference to the accompanying sheet of drawings making part of this specification: Figure 1 is a perspective view of a corrugated caterpillar-trap which embodies my invention. Fig. 2 is a section of the corrugated-trap in perspective. Fig. 3 is a perspective top-view of the corrugated-shedder; and Fig. 4 is a side elevation of a tree-trunk, and the corrugated-trap with its corrugated-shedder fixed to it.

Similar letters refer to similar parts in the several views.

A is a double-cylinder or trap preferably made of sheet metal and composed of the corrugated bottom, *a*, which is integral with the corrugated cylinders or sides, *b, c*, which form a corrugated annular-space, *d*, for containing a sticky-liquid, and a corrugated central-opening, *e*, for the trunk B of a tree.

For placing the corrugated-trap around the trunk B, it is divided diametrically, and the contacting edges provided with flanges C, the ends, *f*, of which are higher than the middle, *g*. In applying the corrugated-trap to the trunk B, the flanges C are brought together around it, and after packing, *h*, is placed between them they are bolted together as shown at, *i*. The central or middle reduction, *g*, in the height of each flange, is to permit the sticky-liquid of the annular-space, *d*, to circulate over the flanges, and thus prevent the caterpillars from crawling over them to the tree-trunk, and to be destroyed while endeavoring to cross the sticky-liquid.

To intercept rain and keep it from dropping into the trap and diluting the sticky-liquid, I fix a corrugated sheet metal shedder D around the trunk B, at a suitable distance above the trap. It is in sections, *j*, provided with flanges, *k*, which are bolted together at, *l*, for catching and dropping rain beyond the outer rim of the trap. The corrugated inner-rim forms the trunk-opening, *m*.

I claim—

1. A caterpillar trap, composed of the divided corrugated double cylinders *b, c* and a corrugated bottom *a* at right angles to the cylinders and integral therewith, the whole forming an annular space capable of holding a sticky liquid, combined with bolting flanges which form the dividing walls between the sections of the cylinders, said walls being higher at the ends than at the middle thereof, substantially as and for the purposes described.

2. A caterpillar-trap composed of a divided and corrugated double-cylinder having a corrugated central-opening for embracing a tree-trunk, and a corrugated-bottom between the cylinders forming an annular-space capable of holding a sticky-liquid, bolting-flanges which

are higher at the ends than at the middle, and a corrugated rain-shedder embracing the same tree-trunk at a suitable distance above the trap, for the purpose shown and described.

- 5 3. A caterpillar-trap having its corrugated members provided on their inner ends with the bolting-flanges C which are united laterally together and constructed to form the corrugated collar, c, which is adapted to embrace
10 the trunk of a tree, each section having its bolting-flange extending radially from the

corrugated trunk-collar to the corrugated and vertical segmental-shell and forming with the corrugated flat-bottom of the member a semi-circular receptacle, for the purpose shown and described. 15

In testimony whereof I affix my signature in presence of two witnesses.

THOMAS D. NOONE.

Witnesses:

FRANCIS D. PASTORIUS,
JAMES M. CASSADY.