

CALLINAN LAWRIE

Private Bag 7, Kew

Victoria 3101, Australia

Facsimile:

61 (3) 853.0062

61 (3) 853.0728

A U S T R A L I A

87 1437

PATENT

NOTICE OF ENTITLEMENT

I, MICHAEL EDER, of Weidengasse 9, A-9900 Lienz, Austria, being the applicant and the person nominated for grant of patent in respect of Australian Patent Application No. 36210/93

state the following:-

STANDARD PCT-CONVENTION FILING

- (a) The person nominated for the grant of the patent:
 - (i) is one of the actual inventors of the invention and has entitlement from the other actual inventor by virtue of assignment; and
 - (ii) is one of the applicants of the basic application; and
 - (iii) has entitlement from the other applicant of the basic application by virtue of assignment.
- (b) The basic application listed:
 - (i) in the declaration made under Article 8 of the PCT is the first application made in a Convention country in respect of the invention.

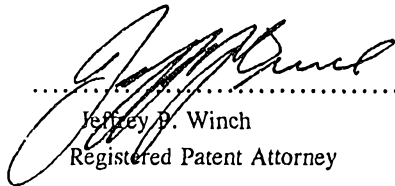
.....
Jeffrey P. Winch
Registered Patent Attorney

27 April 1995
.....
Date

To: The Commissioner of Patents





AU9336210

(12) PATENT ABRIDGMENT **(11) Document No. AU-B-36210/93**
(19) AUSTRALIAN PATENT OFFICE **(10) Acceptance No. 671437**

(54) Title
SPRAYING DEVICE

International Patent Classification(s)
(51)⁵ **B05B 015/04** **B05B 015/12**

(21) Application No. : **36210/93**

(22) Application Date : **16.03.93**

(87) PCT Publication Number : **WO94/02254**

(30) Priority Data

| (31) Number | (32) Date | (33) Country |
|----------------|-----------------|-------------------|
| 1443/92 | 15.07.92 | AT AUSTRIA |

(43) Publication Date : **14.02.94**

(44) Publication Date of Accepted Application : **29.08.96**

(71) Applicant(s)
MICHAEL EDER

(72) Inventor(s)
MICHAEL EDER; FRANZ WALDNER

(74) Attorney or Agent
CALLINAN LAWRIE , Private Bag 7, KEW VIC 3101

(56) Prior Art Documents
JP 03-026370
FR 115590
EP 260539

(57) Claim

1. A spray treatment apparatus comprising : a support for articles and a collector device for collecting the spray medium which passes said articles and said support, wherein said collector device has an endlessly circulating belt which is independent of said support, including means which bear against said belt for bringing spray medium which lies on said belt together to form at least one line of said spray medium, which is narrower than said belt width, and wherein there is further provided a removal device which bears against said belt and which is arranged downstream of said line-forming means in the conveying direction, for removal of said line or lines from said belt.



| | | |
|--------------------------------------------------------------------------------------------------------------------------------------------------------------------------------------------------------------------------------------------------------------------------------------------------------------------------------------------------------------------------------------------------------------------------------------------------------------------------------------------------------------------|------------------------------------------------------------------------------------------------------------------------------------------------------------------------------------------------------------------------------------------------------|----------------------------------------------------------------------------------------------------------------------------------------------------|
| <p>(51) Internationale Patentklassifikation 5 : B05B 15/04, 15/12</p> | <p>A1</p> | <p>(11) Internationale Veröffentlichungsnummer: WO 94/02254 (43) Internationales Veröffentlichungsdatum: 3. Februar 1994 (03.02.94)</p> |
| <p>(21) Internationales Aktenzeichen: PCT/AT93/00048 (22) Internationales Anmeldedatum: 16. März 1993 (16.03.93) (30) Prioritätsdaten: A 1443/92 15. Juli 1992 (15.07.92) AT (71)(72) Anmelder und Erfinder: EDER, Michael [AT/AT]; Weidengasse 9, A-9900 Lienz (AT). (72) Erfinder; und (75) Erfinder/Anmelder (nur für US) : WALDNER, Franz [AT/AT]; Industriestraße 17-19, A-9990 Lienz (AT). (74) Anwälte: TORGLER, Paul usw. ; Wilhelm-Greilstraße 16, A-6020 Innsbruck (AT).</p> | <p>(81) Bestimmungsstaaten: AU, CZ, FI, HU, JP, NO, SK, US, europäisches Patent (AT, BE, CH, DE, DK, ES, FR, GB, GR, IE, IT, LU, MC, NL, PT, SE).</p> <p>Veröffentlicht <i>Mit internationalem Recherchenbericht.</i></p> <p>67 14 37</p> | |

(54) Title: SPRAYING DEVICE

(54) Bezeichnung: VORRICHTUNG ZUR SPRITZBEHANDLUNG

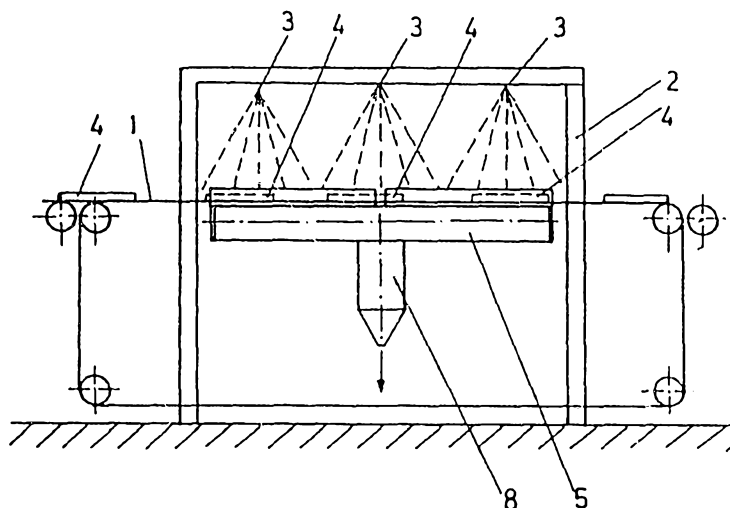

(57) Abstract

A spraying device, in particular for spray-painting objects (4), has a conveyor (1) for transporting the objects and a collector (5) for collecting the medium sprayed past the objects and the conveyor. The collector has an endless circulating belt (5) independent from the conveyor (1) and a device (7, 8) which rests on the belt (5) for removing the medium sprayed thereon.

(57) Zusammenfassung

Vorrichtung zur Spritzbehandlung, insbesondere zur Spritzlackierung von Gegenständen (4) mit einer Fördereinrichtung (1) zum Transport der Gegenstände und mit einer Auffangvorrichtung (5) zum Auffangen des an den Gegenständen und der Fördereinrichtung vorbeistreichenden Spritzmediums. Erfindungsgemäß ist vorgesehen, daß die Auffangvorrichtung ein von der Fördereinrichtung (1) unabhängiges, endlos umlaufendes Band (5) aufweist und daß eine an diesem Band (5) anliegende Abnahmevorrichtung (7, 8) zum Abnehmen von auf dem Band liegendem Spritzmedium vorhanden ist.

Spray treatment device

The invention concerns a spray treatment device, in particular for spray painting articles, comprising a conveyor device or support for the articles and a collector device for collecting the spray medium which passes the articles and the conveyor device or support.

5 When applying spray media or agents (for example when spraying on liquid paint or powder) to articles (workpieces), the problem which arises is that of removing the spray medium which does not go onto the article, and then disposing of it in an environmentally friendly fashion.

10 It is already known for excess spray medium (overspray) to be collected in water which is permeated with coagulation agent, and then to extract therefrom a slurry. The resulting slurry is of course "specialist waste", and the disposal thereof is correspondingly problematical and expensive. In addition the water surface to produce
15 the collection effect cannot be arranged in just any spatial positions and a high level of mechanically technical expenditure is necessary to carry this technology into effect.

 It is further known for the spray medium excess which is deposited on conveyor belts for the articles by an automatic spray
20 machine to be removed mechanically by being scraped or scratched off. Those systems serve primarily for cleaning the conveyor belts. Such a system does not provide for specifically collecting the excess spray medium and for re-use thereof. In addition the conveyor belts have to be dried after the removal operation, before they can come into contact
25 with the articles again. The speed of transportation movement of the spray medium excess is linked to a low speed of transportation movement of the articles in the spray machine, so that a considerable amount of time is lost between the step of spraying on the spray medium and removing the excess from the conveyor belts. Due to the increased
30 evaporation of solvents, that not only results in a greater degree of environmental pollution, but it also results in greater difficulties in

removing the spray medium from the conveyor belts.

In addition, it is already known from German laid-open application (DE-OS) No 28 23 958, in a spray cubicle or booth in which the articles are suspended on hooks, to use a circulating belt to form a vertical curtain for the portion of the spray medium which passes the articles, with the spray medium which is deposited on the belt then being stripped from the belt mechanically.

In accordance with an aspect of the invention, the basic starting point taken by the invention is an automatic spray treatment apparatus in which the articles are automatically moved continuously or stepwise by a conveyor device or support. So that the spray medium which is sprayed past the articles can be collected as completely as possible and possibly fed to re-use thereof, the invention provides that the collector device has an endlessly circulating belt which is independent of the conveyor device and that there is provided a removal device which bears on the belt, for removing spray medium lying on the belt.

In that apparatus, the conveyor device will desirably be so designed that it affords as little engagement surface area as possible for the spray medium, which is advantageously possible for example by the provision of two or more juxtaposed narrow conveyor belts. The endless collector belt runs on the side of the articles which is remote from the spray jets, the spray medium impinging on the collector belt being removed therefrom by means of a removal device which bears against the belt. An important consideration in that respect is the fact that the endlessly circulating belt, for collecting the excess spray medium, is movable independently of the conveyor device (preferably narrow juxtaposed conveyor belts). That makes it possible for the conveyor speed of the belt for collecting the spray medium to be adjusted independently of the conveyor speed of the articles through the spray installation. It is thus possible for the conveyor speed to be adapted

to the respective spray media used, for example by means of an infinitely variable control drive for the belt. In particular it is possible for the belt for collecting the excess spray medium to be caused to run substantially faster than the conveyor device which is responsible for transporting the articles through the spray apparatus. In that way, in particular when dealing with solvent-bearing paints, it is possible to prevent excessive evaporation of solvent, which on the one hand protects the environment and which on the other hand permits the paint to be more easily removed from the belt, because of the lower viscosity.

The belt for collecting the spray medium may advantageously be movable transversely to the conveying direction of the conveyor device. That permits a more space-saving arrangement of the belt provided for collecting the spray medium and the removal device, as well as the associated drive assemblies. In addition such an arrangement for collecting the excess spray medium can be easily subsequently fitted to many existing types of automatic spray treatment apparatuses.

Particularly in the case of larger installations (wider belts for collecting the excess spray medium), there is the problem of removing the spray medium from the collector belt as completely as possible. In order to resolve that problem, it is provided in accordance with the invention that there is firstly formed on the belt, for example by means of lips pressed thereagainst, one (or more) line of the spray medium, on the belt, the width of which is substantially less than the belt width. Then in a second step that line of spray medium is completely removed from the belt by a removal unit. With that mode of operation it is also possible satisfactorily to involve the edge regions of the belt. In addition, that separation in terms of forming the line or lines of spray medium and removal thereof from the belt makes it possible to use smaller components which are better adapted to their respective functions and which, besides a better removal effect, also

permit easier handling (in particular cleaning when changing colour).

A two-stage removal operation of that kind, in which firstly a line of spray medium is formed on the collector belt and then that line is removed by way of a removal device, can also be used in spray
5 treatment apparatuses in which the articles are not moved automatically by a conveyor device, but also rest in operationally fixed supports. Further advantageous features of the invention can also be used both in spray treatment apparatuses with automatic transportation of the articles and also in spray treatment apparatuses with supports which are
10 stationary in operation. In order to cover those two options with one term, the present application uses the term "support" both for supports which are fixed in operation and also for moving supports (top run of the conveyor device) of an automatic spray treatment apparatus.

Further advantages and features of the invention are described
15 in greater detail hereinafter with reference to the following specific description. In the drawing:

Figure 1 is a diagrammatic side view of an embodiment of the spray treatment apparatus according to the invention, in which the articles are automatically moved by way of a conveyor device,

20 Figure 2 is a diagrammatic plan view of the Figure 1 embodiment,

Figure 3 is a side view of the belt for collecting the excess spray medium together with a removal device,

Figure 4 is a plan view of Figure 3,

Figure 5 is a front view of Figure 3,

25 Figure 6 shows a detail of a device for applying an additional agent (solvent) and a lip as a line-forming means,

Figure 7 is a plan view of Figure 6,

Figure 8 shows a spray treatment apparatus in which the articles lie on supports which are fixed in operation, with an embodiment of the
30 system according to the invention for catching and collecting the excess spray medium,

Figure 9 is a plan view of Figure 8,

Figures 10 and 11 are a side view of an embodiment in which the supports together with the belt for collecting the excess spray medium can be pivoted upwardly,

5 Figure 12 is a diagrammatic view in longitudinal section through a part of an embodiment of a belt for collecting excess spray material,

Figure 13 is a highly diagrammatic view to illustrate re-use of the collected spray medium (paint),

10 Figures 14a - f show alternative configurations of the invention in a plan view onto the belt for collecting excess paint material,

Figures 15a - e show alternative configurations of the invention in a diagrammatic side view onto the belt for collecting excess spray medium,

15 Figures 16a - c show alternative configurations of the belt with the application of additional agents,

Figures 17a - c show alternative configurations of the belt with the belt guided in a triangular arrangement, and

Figure 18 shows a specific belt support.

20 Figures 1 and 2 show an automatic apparatus for spray treatment (spray painting) of articles comprising a conveyor device 1 for moving the articles to be painted through the actual spray cubicle or booth 2. The spray medium is applied to the articles 4 from above by way of spray nozzles 3 which are not shown in detail.

25 To collect the spray medium which goes past the articles 4, an endlessly circulating belt 5 is disposed just beneath the conveyor device 1. The top run of the endless belt which is past over direction-changing rollers 6 (of which one is driven) is disposed in parallel relationship just beneath the supports for the articles 4, which, in the present embodiment, are formed by a plurality of endlessly circulating,
30 narrow conveyor belts of the conveyor device 1. The intermediate space between the conveyor belts is wider than the belt width itself so that

the conveyor belts offer the spray medium the smallest possible engagement surface area, and most of the spray medium which does not pass onto the articles goes onto the belt 5. The belt for collecting the spray medium runs transversely relative to the conveying direction
5 of the conveyor device 1. That permits the belt 5 to be guided in parallel just below the conveyor belts 1, while the line-forming lips 7 which are still to be described and the removal pipe 8 can be arranged laterally outside the conveyor device 1. In that way the conditions in respect of space are put to optimum use and the collector belt with
10 removal device, in accordance with the invention, can be subsequently fitted in existing automatic spray installations. The fact that the belt is guided just beneath the support for the articles 4 (0.2 mm to 5 cm, preferably 0.2 mm to 2 cm), prevents excess paint material from undesirably impinging on the underside of the articles 4 (overspray).

15 In accordance with a preferred feature of the invention removal of the spray medium which lies on the belt 5 is effected by a procedure whereby a line 9 of the spray medium, which is narrower than the width of the belt 5, is firstly formed by way of line-forming means. The line 9 of spray medium is then removed from the belt by way of a removal
20 device which bears against the belt. In the present embodiment said line-forming means comprise two lips 7 which can be resiliently pressed against the belt 5 and which are set at a slight angle of inclination relative to the conveying direction 10 of the belt 5 and thus form a single line 9 of the spray medium, which extends on the middle of the
25 belt 5. That line 9 can be easily and completely removed by a removal pipe 8 which is resiliently pressed against the belt from below.

Figures 3 to 5 show the belt 5 and further details of the spray medium removal system. Arms 12 for the lips 7 are mounted pivotably about a vertical axis 13 on a frame 11. In addition the arms 12 can be
30 moved in the direction of the arrows 14, that is to say lifted off the belt 5 or pressed thereagainst. In operation the angular position of

the carrier arms 12 is approximately as shown in Figure 4, a small spacing remaining between the lips 7 in the middle of the belt, and the line of paint formed by the lips 7 issuing through that spacing. In operation that angular positioning is maintained by suitable stops, in which case the carrier arms 12 together with lips 7 are pressed against the belt 5 in a vertical direction from above. For that purpose for example pneumatic devices or springs (not shown) can be provided. For the purposes of cleaning the lips 7, the arms 12 can be lifted off and pivoted forwardly about the vertical axes 13. That is a decisive handling advantage, in particular when changing colours.

For removal of the central line of paint formed on the belt 5 by the lips 7, the arrangement has a removal pipe 15 which is resiliently pressed from below against the belt 5 (for example by way of a pneumatic device or a spring device (not shown)). In this embodiment, the contact location of the edge of the pipe is just downstream of the direction-changing roller 6. At this point, it is possible for the edge of the pipe to be pressed snugly against the belt 5. The completely removed line of spray medium issues in the direction of the arrow 16 downwardly out of the pipe 15 and can be collected in a collecting container. From the container, it is possible for the paint to be used again. The pipe 15 can also be lowered in a vertical direction and then possibly removed, and can thus be easily cleaned. In principle it is also possible to adopt other removal devices such as for example channels which are easy to clean.

In order in particular when using solvent paints to produce the original viscosity and/or to facilitate formation of the line of paint or removal of the spray medium on the belt 5, a preferred embodiment of the invention can provide that a device 15 for applying an additional agent, preferably a paint solvent, is arranged just upstream of the removal device 5 or just upstream of the line-forming means (lips 7) respectively. The device 15 can have a continuous supply line 17 for

the additional agent and a plurality of nozzles 16 which are distributed over the width of the belt 5. The additional agent can be applied in a very wide range of different ways. For example it can be applied by spraying or by dropwise trickling. Advantageously, the device 15 for
5 applying the additional agent and the line-forming means (lips 7) form a structural unit, insofar as they are jointly fixed to the carrier arm 12, as shown in Figures 6 and 7. In that way the device 15 can always be set in an accurately defined relative position with respect to the lips 7 and can move away from the belt, jointly with the lips 7.

10 As Figure 6 shows, the side 7a of the lip, that is towards the spray medium, includes an acute angle α with the belt surface 5a. That has proven to be advantageous in regard to a good line-forming function and a low level of material wear on the belt 5.

Figures 8 and 9 show an apparatus for the spray treatment of
15 articles 4, wherein the article 4, in operation, rests on fixed supports and is not automatically transported. The supports are formed by thin wires 18 which are stretched transversely over the endlessly circulating belt 5. The wires 18 on which the article 4 is supported by way of support portions 20 on the wires 18 are held laterally in holders 21
20 which are fixed on carriages 22. The carriages 22 can be displaced in the belt conveying direction on rails 19 and thus permit adaptation to the article 4 to be laid thereon. In principle those carriages 18 could be used for automatic transportation of an article. In the case of the embodiment illustrated in Figures 8 and 9 however the idea is that,
25 before the article is fitted in position, the carriages 18 are displaced along the rails 19 into the appropriate position and are then clamped fast there.

The top run of the endless belt 5 extends just beneath the supports 18 and thus prevents the unintended deposit of overspray on the
30 underside of the article 4. The thin wires 18 afford scarcely any engagement surface area for the spray medium to land thereon which can

thus be collected entirely by the subjacent belt 5, insofar as the spray medium does not in any case impinge on the article 4. A removal system is provided on the vertical region of the belt 5 which is guided in a generally L-shaped configuration, for removal of the excess spray medium
5 which is on the belt 5. The removal system has a device 15 for applying solvents, a line-forming means in the form of one or more lips resiliently pressed against the belt 5 and finally a removal device 8 in the form of a pipe. The belt 5 is driven by way of a drive 23 and a drive belt 24.

10 Removal on a vertical region of the belt 5, as shown in Figure 8, permits the individual components to be arranged in a compact and easily accessible manner.

Upon manual spraying of articles 4 which rest on non-slip supports 20 on the wires 18, a preferred alternative form of the
15 invention provides that the support (wires 18 with members 20) with the belt 5 for collecting the excess spray medium is mounted on a main body 27 pivotably about a horizontal axis 26. For upward pivotal movement the arrangement may have a for example pneumatic displacement device 25 which, as shown in Figure 11, has a stroke travel H. The relative
20 position as between the article and the collector belt remains fixed due to the common upward pivotal movement of the support and the belt. In particular the belt 5 can still be guided just beneath the articles 4. The upward pivotal movement permits good accessibility for the surface of the articles 4 for manual application of paint by way of a spray gun
25 (not shown).

For good removal of the spray medium on the belt, the belt 5 itself is also of importance, besides the above-mentioned line-forming lips and the removal pipe. It has been found desirable if the belt 5 for collecting the spray medium has a surface structure 28, that is to
30 say, it does not have an entirely smooth surface (Figure 12). If the belt has a structured base fabric, that surface structure, that is to

say slightly raised portions and depression portions, can be formed by the structured base fabric 29 (for example of polyester in warp and weft) showing through a thin coating lying thereon (for example a few tenths of a millimetre of urethane). That structured surface also has
5 advantages in regard to minimum possible reflection of the spray medium particles which impinge on the belt 5. A Shore hardness in accordance with DIN 53505 in the range of 70-100 is particularly desirable in regard to good removal of paint from the belt 5.

Figure 13 diagrammatically shows how the spray medium which has
10 been removed from the belt 5 by way of the lips 7 and the removal pipe 8 can be re-used. The spray medium passes out of the pipe 8 into a storage container 31 and from there by way of a pump 32 into a device for detecting its viscosity. In the device 34, solvent is added from a solvent container 35 in dependence (control line 40) on the detected
15 viscosity 33, in order to restore the viscosity of the spray medium to a predetermined value. As the speed of the belt 5 can be selected to be very high, scarcely any solvent escapes on the way to the removal location, so that the addition of solvent is restricted to small amounts. The reprocessed spray medium then passes into the storage
20 container 36 from which it is conveyed by way of a pump 37 to the actual spray nozzles 3. The essential consideration in regard to Figure 13 is that the spray medium which is removed from the belt is ultimately fed to the nozzles 3 again in an automatic circuit, and therefore there is no need to dispose of it. That not only reduces environmental
25 pollution, but it also provides considerable savings on material costs.

Alternatively or in addition to the addition in the external device 34, the solvent for adjusting viscosity can also be added to the spray medium on the belt, before it is removed from the belt 5 (which also makes it easier to remove the spray medium from the belt). The
30 application of solvent can be effected in an unregulated manner, for example on the basis of manually set experimental values. It seems more

advantageous however (as is shown in Figure 13) for the addition of solvent to be regulated by way of the line 41 and the metering control device 42, in dependence on the detected viscosity. It is also possible for solvent to be added in amounts which can be predetermined easily, by way of the device 15, with subsequent adjustment to the correct viscosity then being effected in the device 34.

Figures 14a - f show alternative configurations of the invention. In Figure 14a the arrangement has a plurality of successively arranged lips 7 which overlap one behind the other in the central region, in the conveying direction 10. That arrangement is distinguished by particularly complete removal of the spray medium on the belt 5. It should be mentioned in this respect that complete removal of spray medium from the belt 5 is admittedly advantageous in the case of the present invention, but it is not absolutely necessary in contrast to the conveyor belts of earlier apparatuses. In contrast, absolutely complete cleaning was necessary with the earlier conveyor belts, in order reliably to prevent contamination of the newly applied articles. In the case of the belt 5 according to the invention, a small amount of spray medium which is transported around on the belt does not in principle interfere with the mode of operation of the arrangement. In order to clean the belt prior to a change in colour, it can be provided that, after termination of the spraying operation, the belt continues to run on and is thus definitively cleaned of the preceding colour. That can be easily achieved by a suitable control device for the belt drive.

In the alternative configuration shown in Figure 14b, there is a single curved lip 7 with central through opening 7a for forming a narrow line 9 of spray medium which can be removed by the removal pipe 8. In the embodiment shown in Figure 14c the lips 7 are mounted rotatably in the direction indicated by the arrows 35.

In the embodiments shown in Figures 14b and e, the spray medium

is removed in one stage, that is to say, no line of spray medium is formed on the belt 5, but on the contrary the spray medium which is disposed on the belt 5 is guided along the lips 7 laterally into a pipe 8'.

5 In the embodiment shown in Figure 14f, the spray medium is removed into a lateral pipe 8' by a roller 6' which rotates in opposite relationship, and around which a further endlessly guided belt can also be passed.

 Figures 15a to e show further embodiments of the invention. In
10 the alternative configuration shown in Figures 15a and b, the spray medium is removed into a channel 36, the removing lip 7 being formed integrally with the channel 36. As Figure 15c shows, the channel 36 can be fitted to a vertical part of the belt 5 which is guided in an L-shaped configuration. As shown in Figure 15d, the lip 7 can also be
15 displaceable in the conveying direction 10 of the belt. The alternative configuration shown in Figure 15e has a roller member 37 with perforated peripheral portion, around which the belt 5 is passed. In that arrangement the top side of the belt bears against the peripheral surface of the roller member 37, in which case the spray medium passes
20 into the interior of the roller member 37 and can flow axially out of same.

 As already described with reference to Figures 6 and 7, the application of an additional agent, in particular a solvent of the paint used, can be advantageous in terms of improved removal of the paint and
25 re-use thereof. Figures 16a to c show alternative ways illustrating how that additional agent can be applied.

 In Figure 16a the arrangement has a spray nozzle 45 for applying the additional agent to the belt 5. Figure 16b shows an applicator roller member 46 at the underside of the belt, for uniformly applying
30 the additional agent to the belt 5. Such application of the additional agent can also be effected by way of a felt strip 47, as shown in Figure 16c.

In the alternative configuration shown in Figures 16a to c, the additional agent is applied to the belt 5 upstream of the middle region of the belt 5 in which the spray medium which has been sprayed past the articles impinges on the belt. When therefore the spray medium impinges on the belt, the belt is already provided with an additional agent which subsequently facilitates the removal thereof by way of the lip 7 or a removal pipe (not shown) or the like.

Figures 17a to c show alternative configurations in terms of the way in which the belt 5 of the collector device is guided, with the belt 5 being passed over bar or beam members 50a, 50b and 50c which are arranged in a triangle. While affording a compact construction and a short belt length, that arrangement makes it possible for the spray medium 48 to be sprayed on by way of the nozzles 3 on the one hand, while permitting removal of the spray medium 48, which has been sprayed past the articles 4, from the belt 5, by means of the devices 7 and 8 on the other hand, at locations which are spatially well separated from each other, at different sides of the triangle. The removal operation can be effected in particular by first forming a line of spray medium by way of lips 7, followed by removal of that line of spray medium by way of a removal pipe 8.

In order to ensure that the line-forming lips 7 bear properly and satisfactorily against the belt 5, the arrangement may have two rounded-off supports 49 as is shown in Figure 18. The belt is free between those two rounded-off supports 49, that is to say, it is not supported by a support. A line-forming lip 7 which is diagrammatically shown in Figure 18 is pressed against the belt from above in that region.

The lips 7, the removal device 8 and/or the collector or storage containers for removed spray medium can be cooled. That increases the so-called "pot time" during which the paint can be re-used, which is of advantage in particular when using two-component paints.

The claims defining the invention are as follows:-

1. A spray treatment apparatus comprising : a support for articles and a collector device for collecting the spray medium which passes said articles and said support, wherein said collector device has an endlessly circulating
5 belt which is independent of said support, including means which bear against said belt for bringing spray medium which lies on said belt together to form at least one line of said spray medium, which is narrower than said belt width, and wherein there is further provided a removal device which bears against
10 said belt and which is arranged downstream of said line-forming means in the conveying direction, for removal of said line or lines from said belt.

2. The apparatus according to claim 1, for the spray painting of said articles.

3. The apparatus according to claim 1 or claim 2, wherein said line-forming means form a single spray medium line.

4. The apparatus according to claim 3, wherein said spray medium line is on the middle of said belt.

5. The apparatus according to any one of the preceding claims, wherein said line-forming means and/or said removal device includes at least one lip which is set inclinedly relative to the conveying direction of said belt.

6. The apparatus according to claim 5, wherein said at least one lip is resiliently pressed against said belt.

7. The apparatus according to claim 5 or claim 6 wherein said at least one lip is fixed on a carrier arm which is displaceable relative to said belt.

8. The apparatus according to any one of claims 5 to 7, wherein said at least one lip comprises a material which is elastic in itself.

9. The apparatus according to claim 8, wherein said at least one lip is constructed of metals.

10. The apparatus according to any one of claims 5 to 9, wherein that side of said at least one lip which is towards said spray medium includes an acute angle (α) with the surface of said belt.



11. The spray treatment apparatus according to any one of claims 2 to 10, comprising a conveyor device for transporting said articles wherein said belt for collecting said spray medium is movable transversely to the conveying direction of said conveyor device.

5 12. The apparatus according to claim 11, wherein said articles lie on said conveyor device.

10 13. The apparatus according to one of claim 11 or claim 12, wherein said conveyor device has two or more endlessly circulating narrow transportation belts or the like, wherein the intermediate space between said transportation belts or the like is greater than their respective belt widths.

14. The apparatus according to one of the preceding claims, wherein said belt is guided just below said support for said articles.

15 15. The apparatus according to claim 14, wherein said belt is from 0.2 mm to 5 cm below said support for said articles.

16. The apparatus according to any one of the preceding claims, wherein said removal device has at least one pipe which is adapted to be pressed against said belt.

17. The apparatus according to claim 16, wherein said at least one pipe is resiliently pressed against said belt.

18. The apparatus according to claim 17, wherein said at least one pipe is pressed against said belt in the region of a direction-changing roller for said belt.

19. The apparatus according to any one of the preceding claims, wherein there is provided a device for applying to said belt an additional agent.

20. The apparatus according to claim 19, wherein said additional agent is a paint solvent.

21. The apparatus according to claim 19 or claim 20, wherein said device for applying said additional agent includes at least one nozzle for spraying on said additional agent.

30 22. The apparatus according to any one of claims 19 to 21, wherein



said device for applying said additional agent includes at least one applicator roller for said additional agent, said at least one roller bearing against said belt.

23. The apparatus according to any one of claims 19 to 22, wherein said device for applying said additional agent includes at least one applicator which is in contact with said belt and which comprises porous or fibrous material.

24. The apparatus according to claim 23, wherein said fibrous material is felt.

25. The apparatus according to any one of claims 19 to 24, wherein said device for applying said additional agent - as viewed in the conveying direction of said belt is arranged upstream of that region at which said spray medium that passes said articles impinges onto said belt.

26. The apparatus according to any one of claims 19 to 25, wherein said device for applying said additional agent and said line-forming means form a structural unit.

27. A spray treatment apparatus according to any one of the preceding claims, wherein said support has thin wires, threads or the like which are stretched over said belt, wherein said threads, wires or the like are stretched between holders which are mounted on displaceable carriages.

20

28. The apparatus according to any one of claims 1 to 27, wherein the top run of said endless belt is guided parallel to said support or said conveyor device just below same.

25

29. The apparatus according to claim 28, wherein said top run of said belt is from 0.2 mm to 5 cm below said support or conveyor device.

28

30. The apparatus according to claim 29, wherein said top run of said belt is from 0.2 mm to 2 cm below said support or conveyor device.

30

31. The apparatus according to any one of claims 1 to 30, wherein said support together with said belt is mounted on a main body pivotally about axis.

32. The apparatus according to claim 31, wherein said axis is



substantially horizontal.

33. The apparatus according to any one of the preceding claims, wherein said support together with belt is upwardly pivot able.

34. The apparatus according to claim 33, including a pneumatic adjustment device for said upward pivoting of said support together with said belt.

35. The apparatus according to any one of claims 1 to 34, wherein said belt for collecting said spray medium has a surface structure.

36. The apparatus according to claim 35, wherein said belt has at least one structured base fabric which shows through a thin coating disposed thereon.

37. The apparatus according to claim 36, wherein said coating is a plastics material.

38. The apparatus according to any one of claims 1 to 37, wherein the top side of said belt for collecting said spray medium has a Shore hardness in accordance with DIN 53505 of from 70 - 100.

39. The apparatus according to any one of claims 1 to 38, wherein the peripheral speed of said belt for collecting said spray medium is controllable.

40. The apparatus according to claim 39, wherein said peripheral speed is steplessly controllable.

41. The apparatus according to any one of claims 1 to 40, wherein the peripheral speed of said belt for collecting said spray medium is higher than the transportation speed of said conveyor device.

42. The apparatus according to any one of claims 1 to 41, wherein said spray medium which is removed from said belt is collected and fed to a storage container for said spray medium.

43. The apparatus according to claim 43, wherein the viscosity of said removed spray medium is detected and - to produce a given spray medium viscosity - solvent is added to the spray medium in dependence on the detected viscosity.

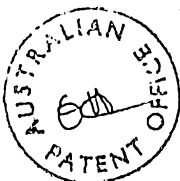

44. The apparatus according to claim 43, wherein said solvent is added to said spray medium on said belt, upstream of said removal device for removal from said belt.

5 45. The apparatus according to claim 44, wherein said solvent is added upstream of said line-forming axis.

46. The apparatus according to any one of claims 1 to 45, wherein said removal device and/or said storage container are at least partially cooled.

10 47. The apparatus according to any one of claims 1 to 46, wherein said belt is guided over two supports, wherein at least one part of said line forming medium or of the said removal device is pressed against the belt which is free between said supports.

48. The apparatus according to claim 47, wherein said supports are rounded.

15 49. The apparatus according to any one of claims 1 to 48, wherein said belt is guided around three rollers which are arranged in a triangle, wherein impingement of said spray medium and removal thereof from said belt are effected at different sides of said triangle.

50. The apparatus according to claim 49, wherein said triangle is a right-angled triangle.

51. A spray treatment apparatus, substantially as described herein with reference to the accompanying drawings.

DATED this 4th day of June, 1996.

MICHAEL EDER
By his Patent Attorneys:
CALLINAN LAWRIE

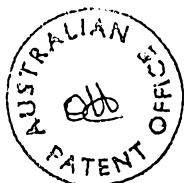

Fig. 1

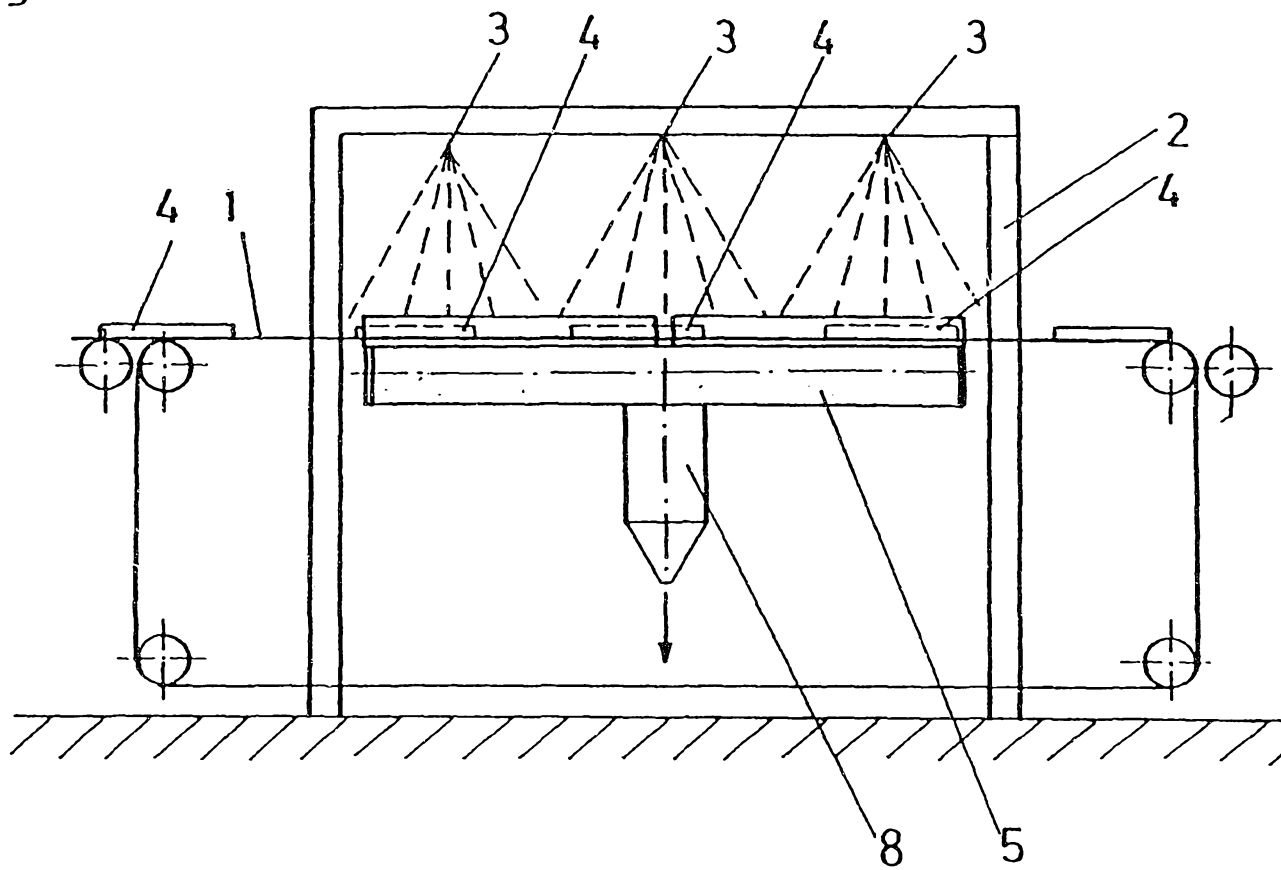

Fig. 2

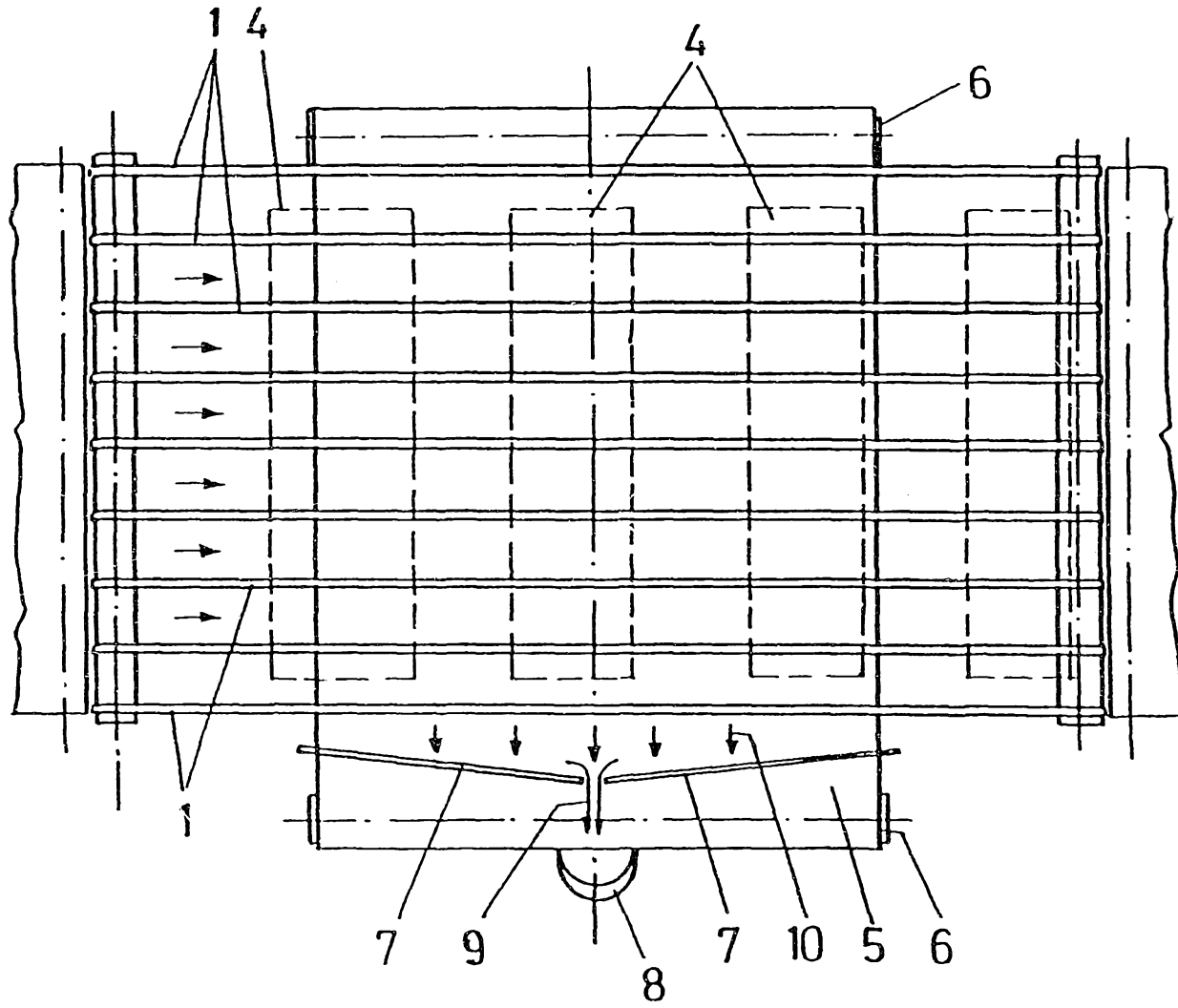

Fig. 3

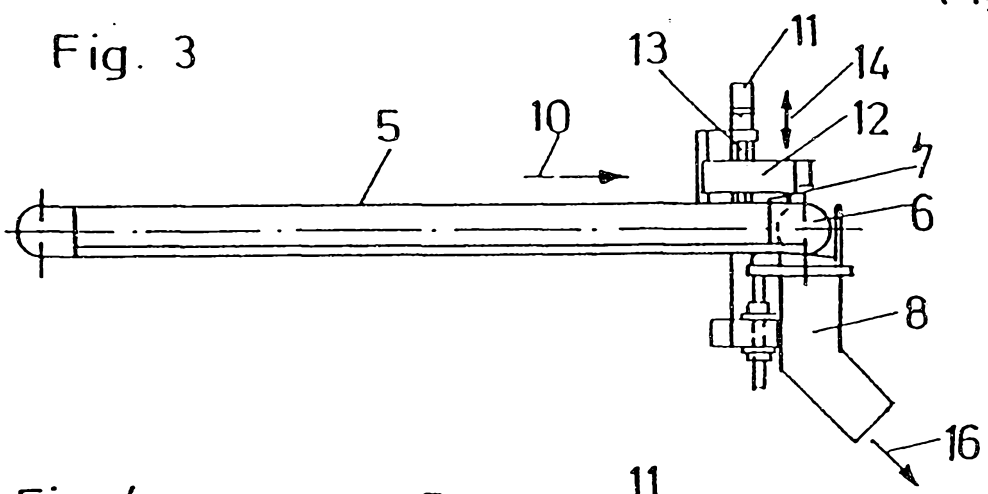

Fig. 5

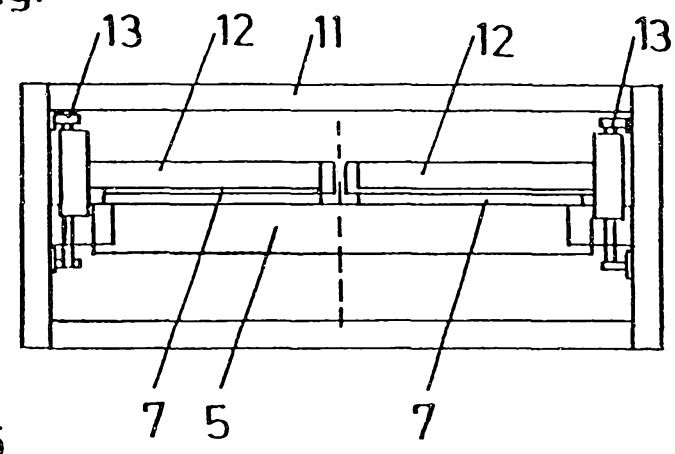
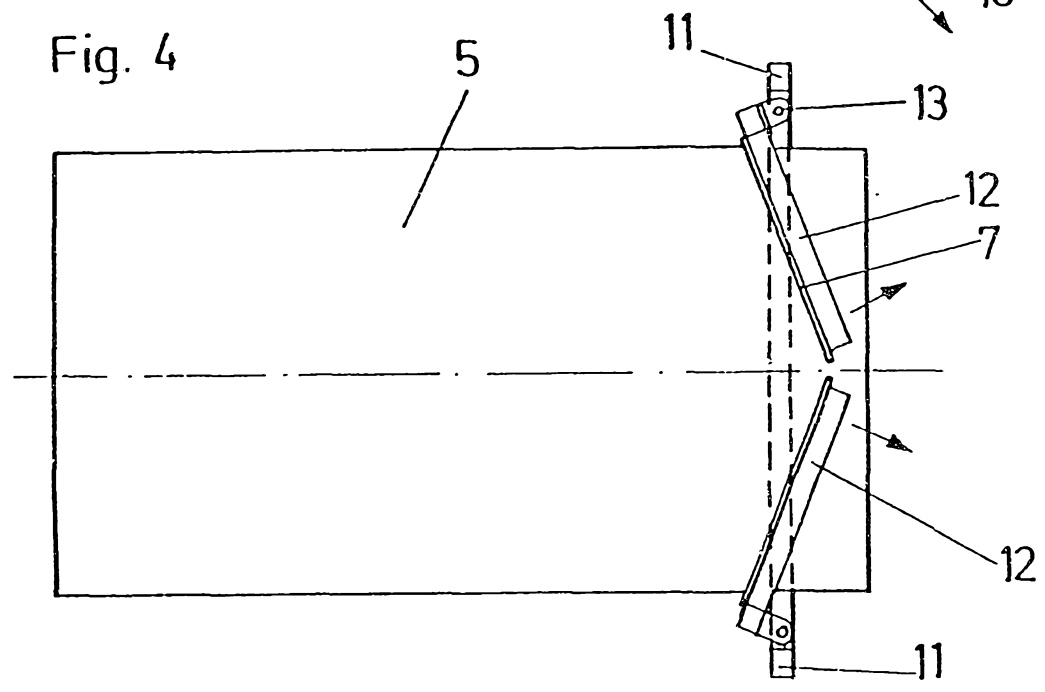

Fig. 4



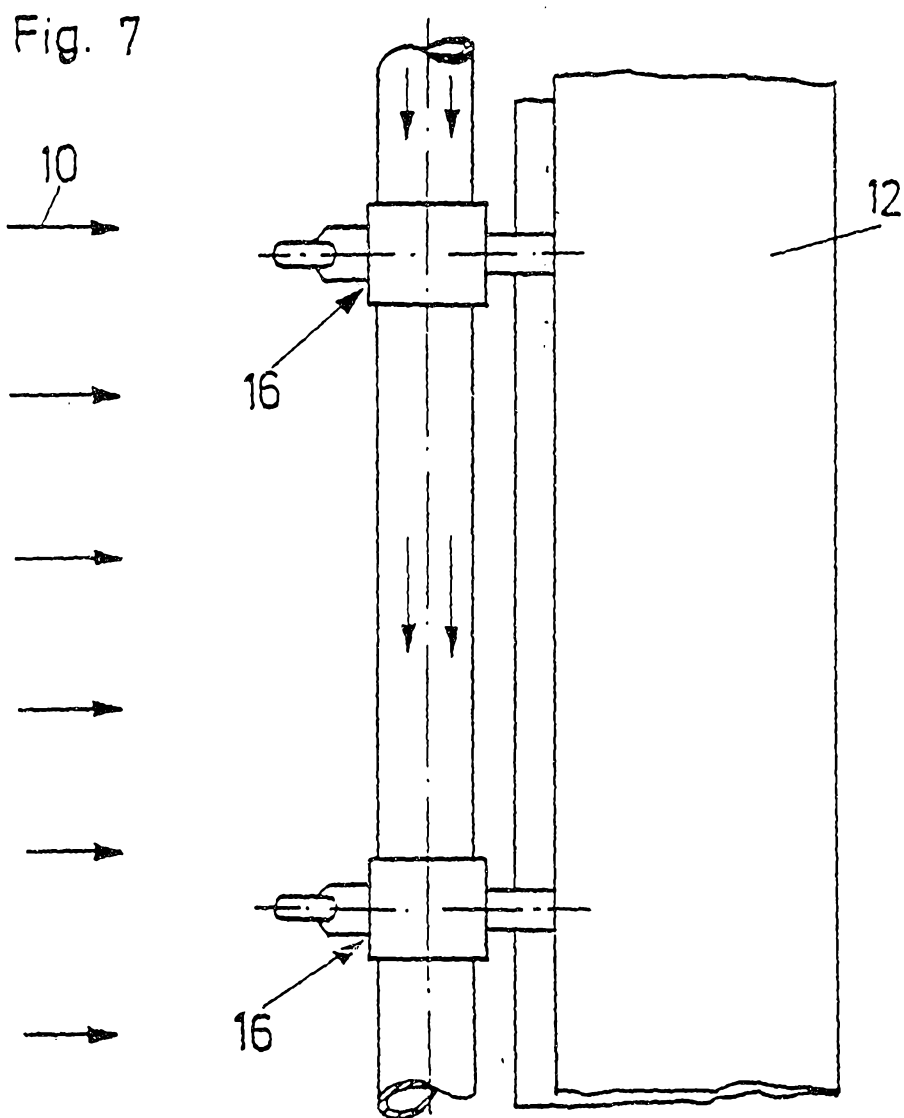
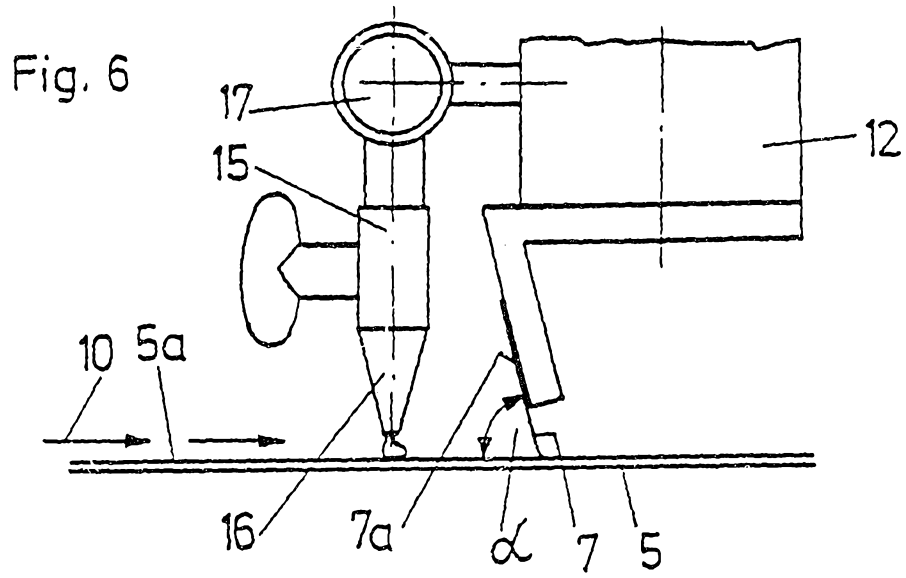
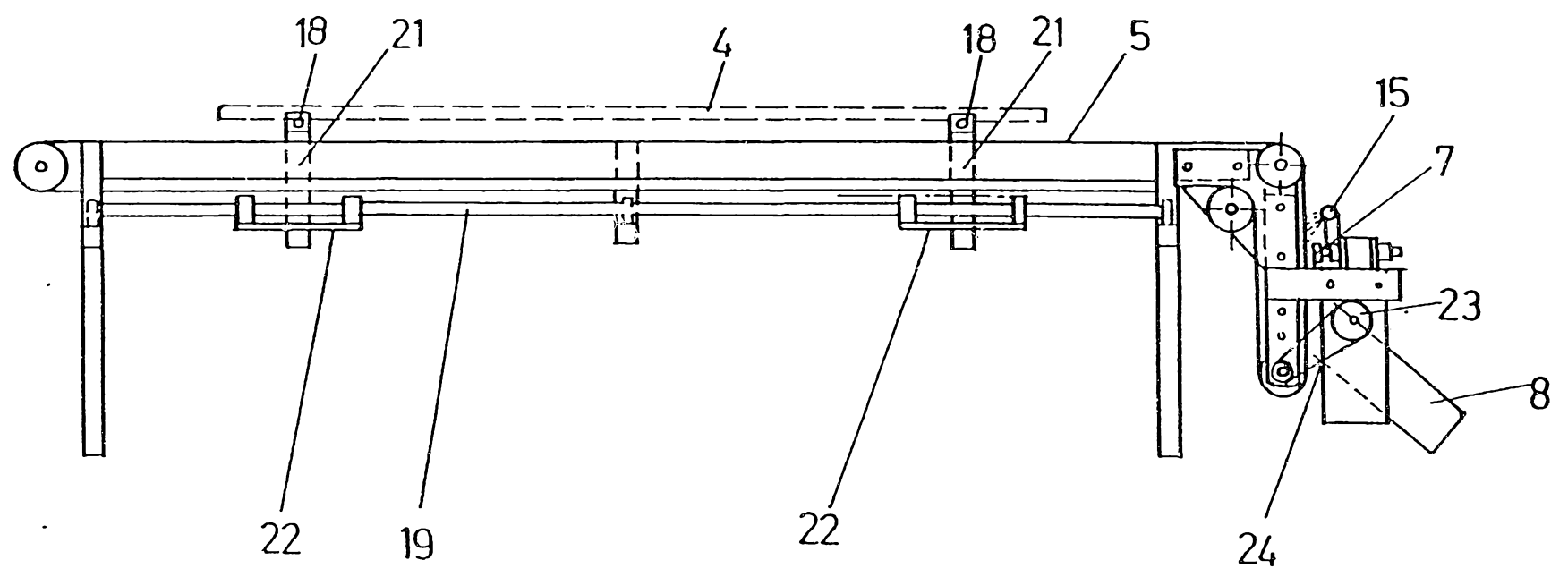

Fig. 8



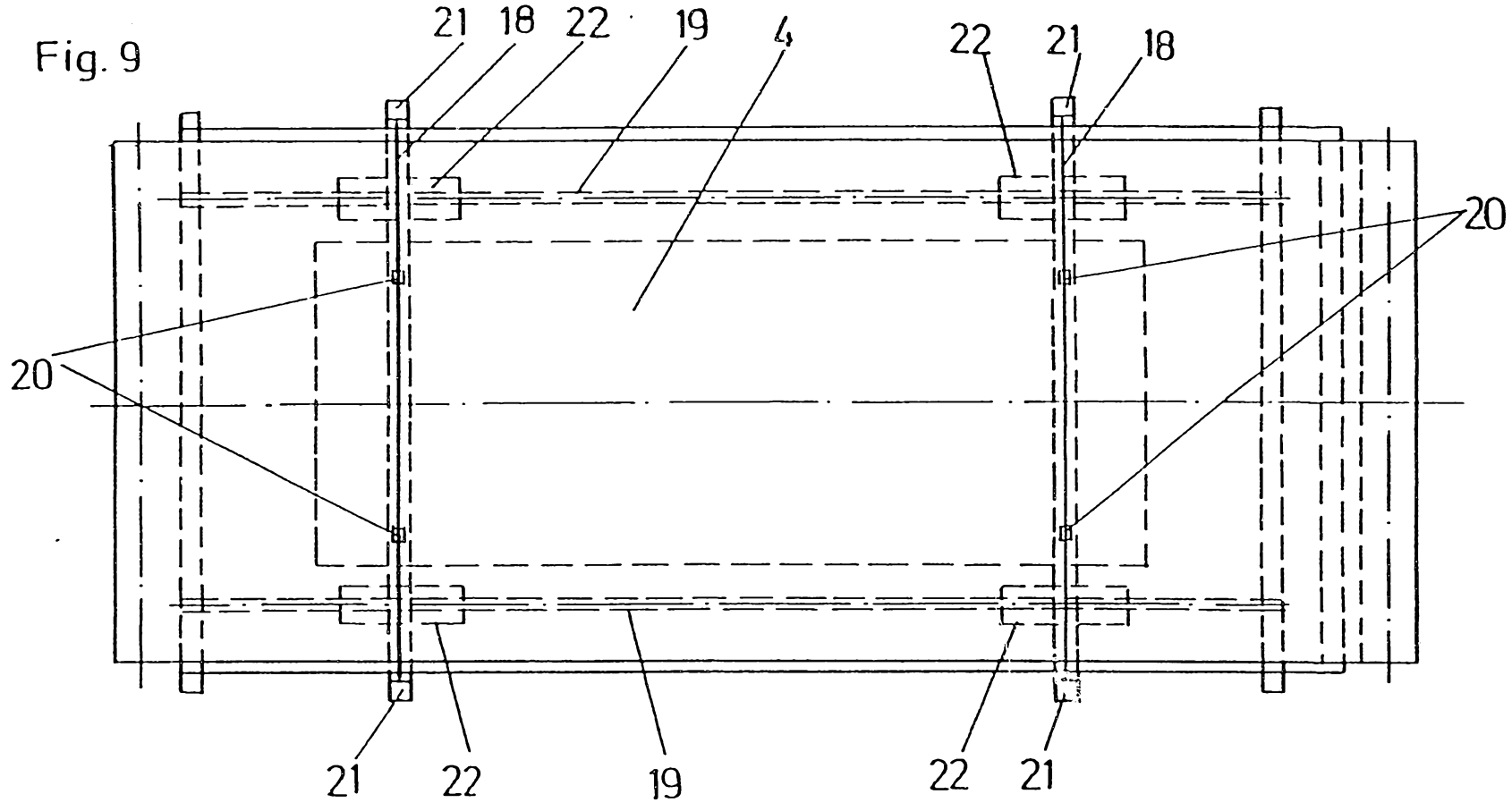

Fig. 10

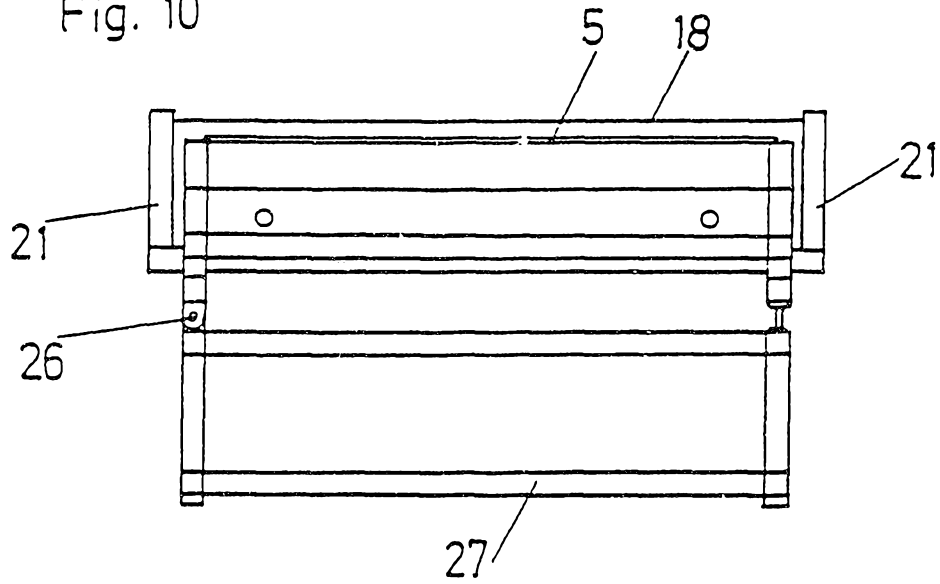

Fig. 11

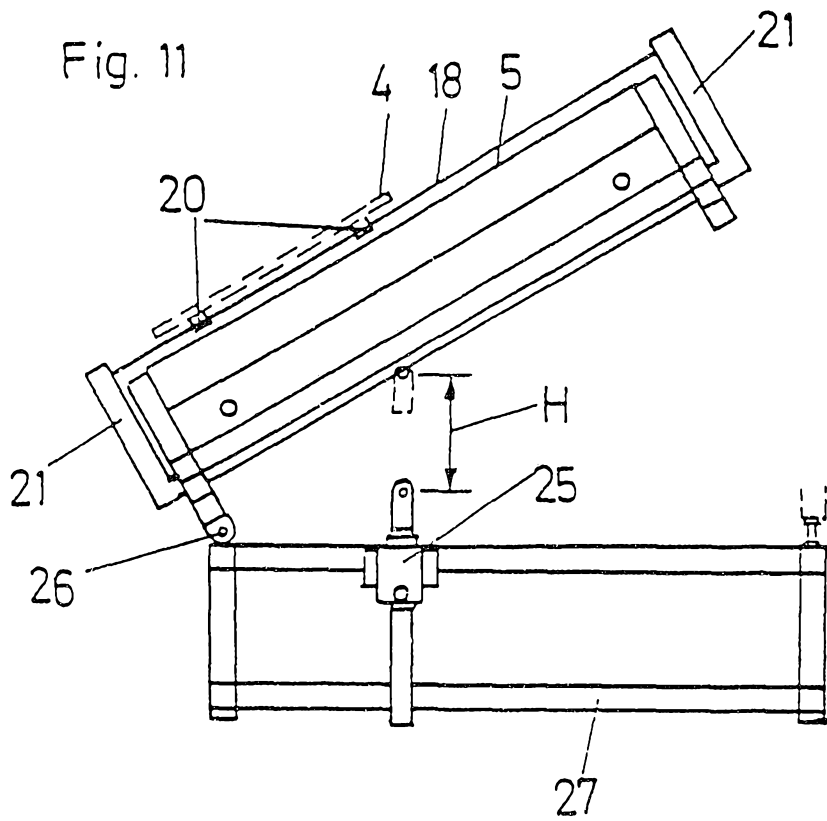

Fig. 12

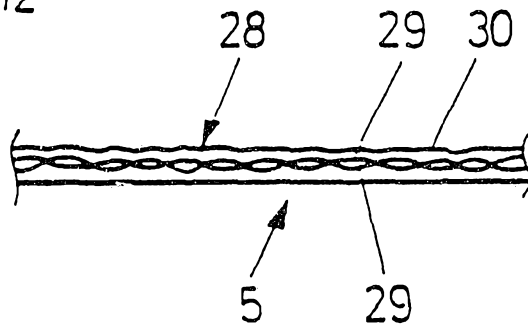
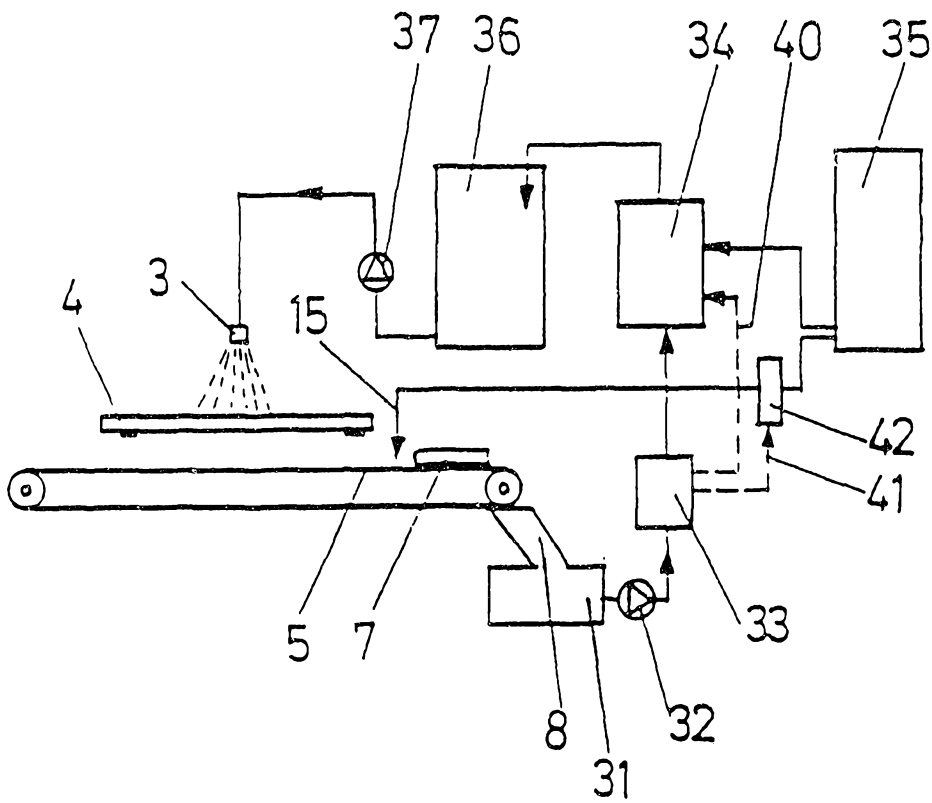

Fig. 13



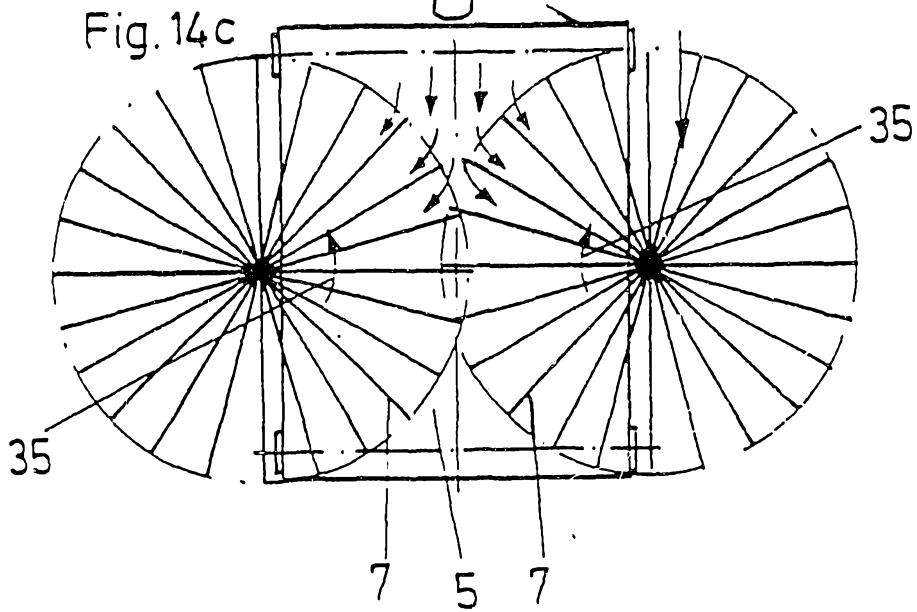
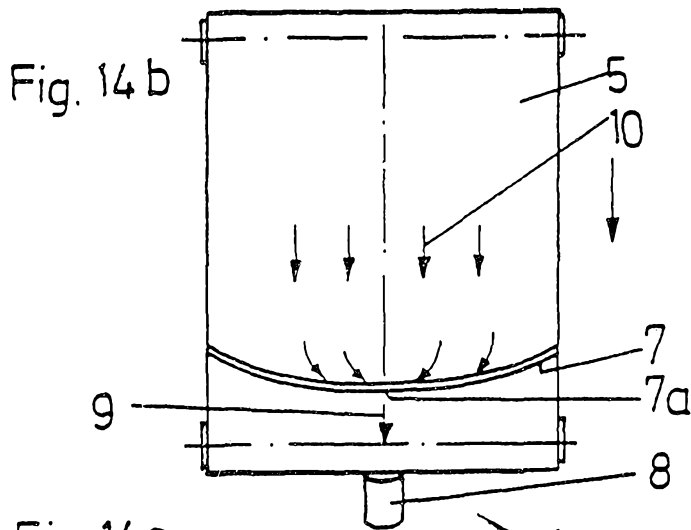
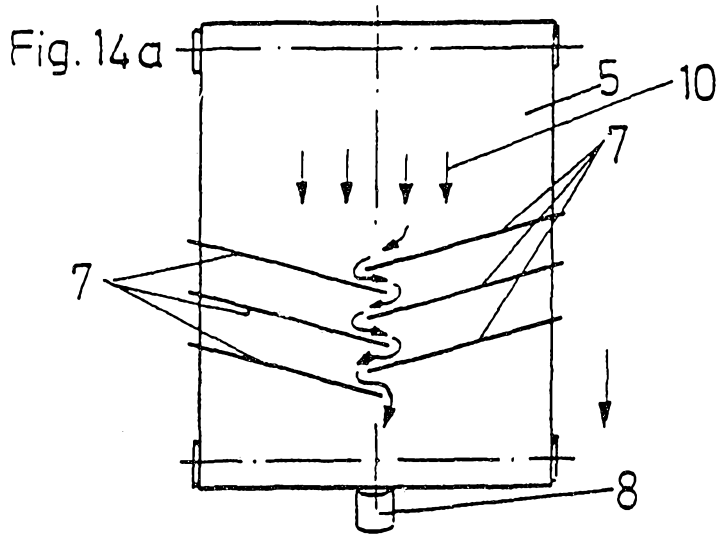

Fig.14 d

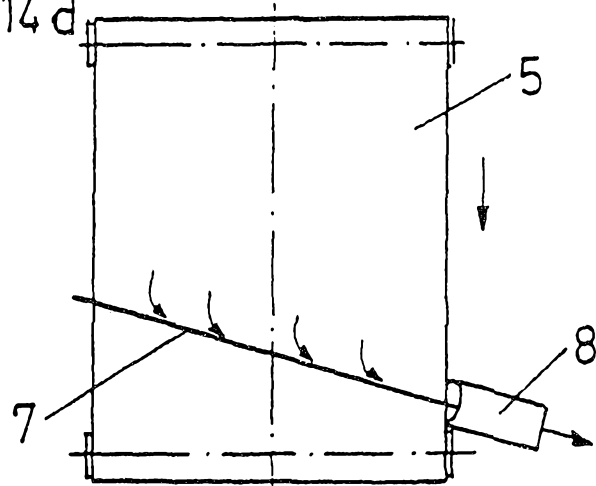

Fig.14 e

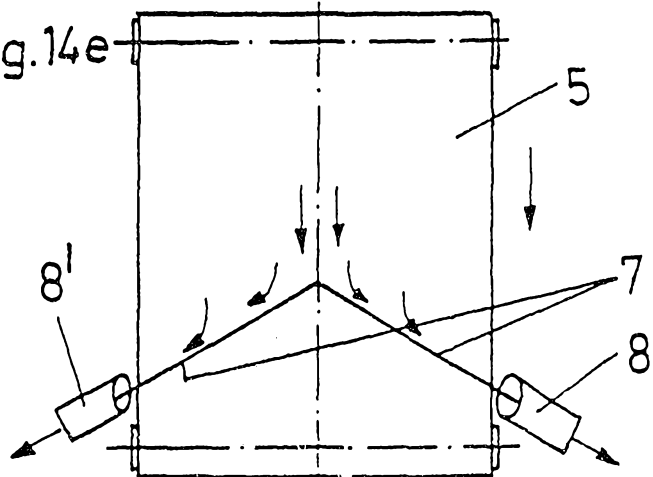
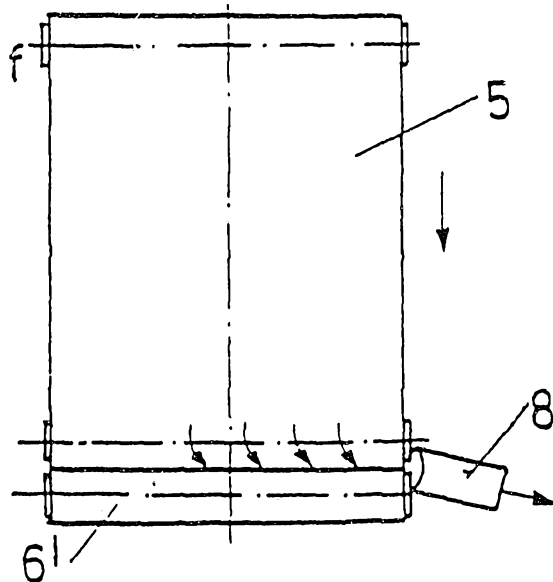

Fig.14 f



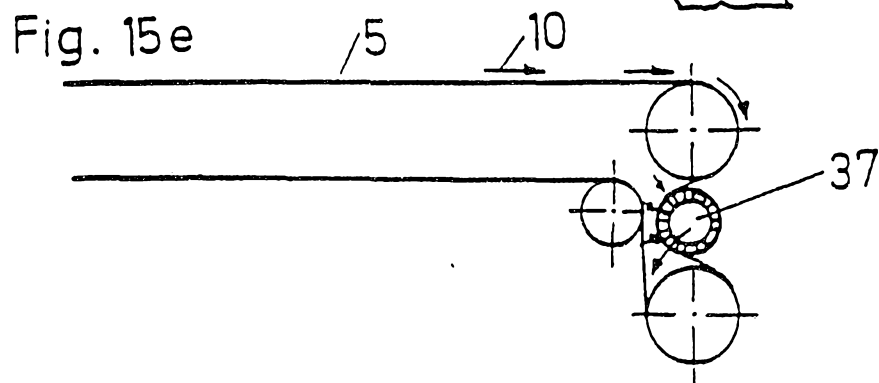
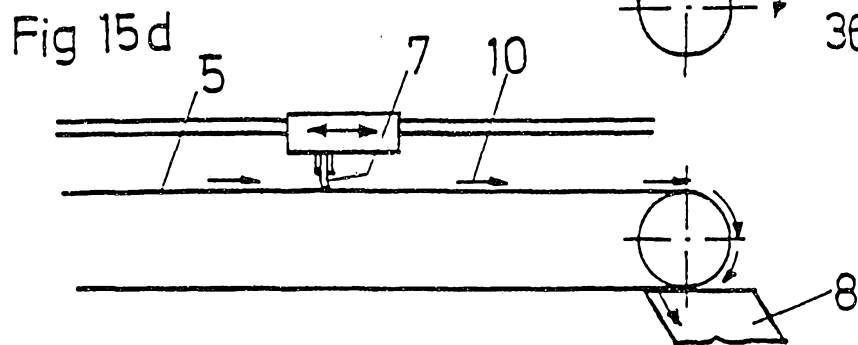
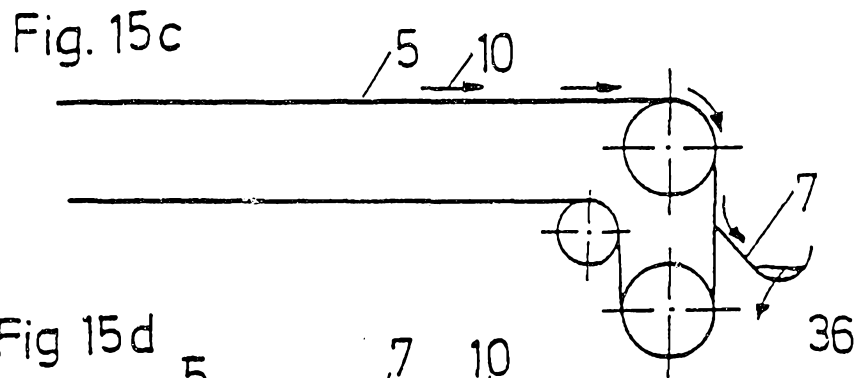
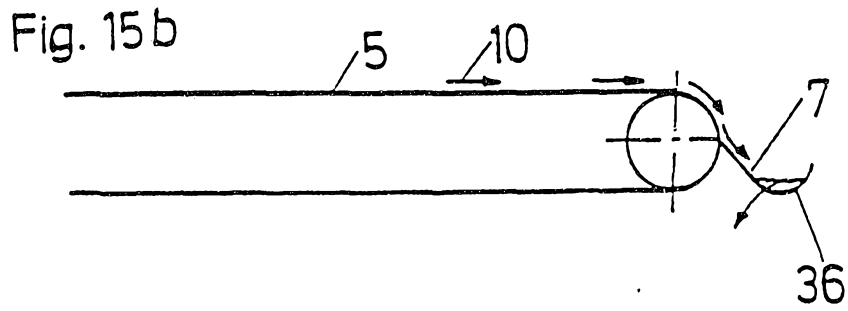
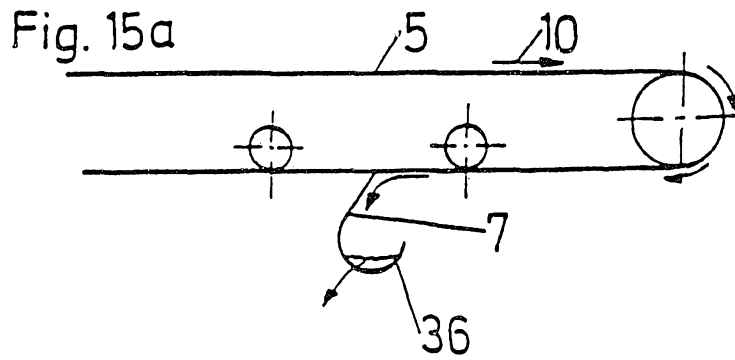

FIG. 16a

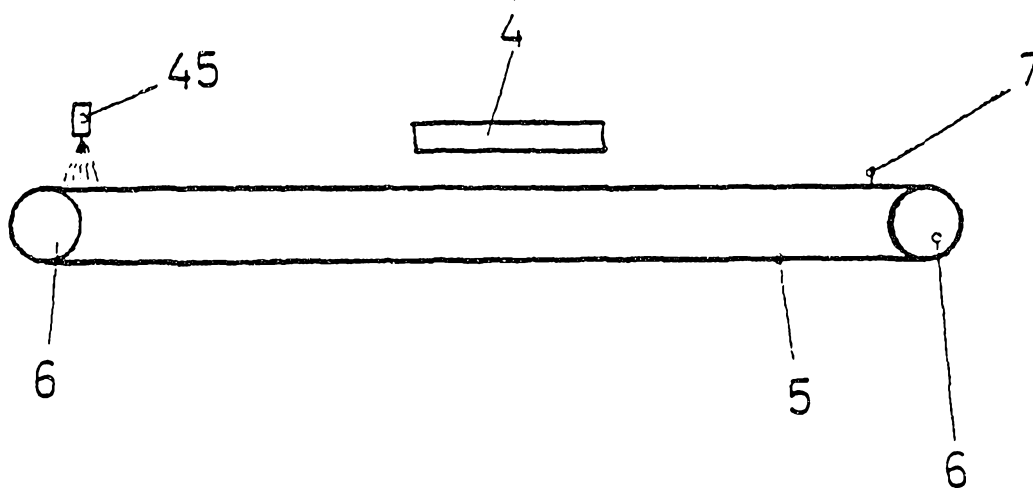

FIG. 16b

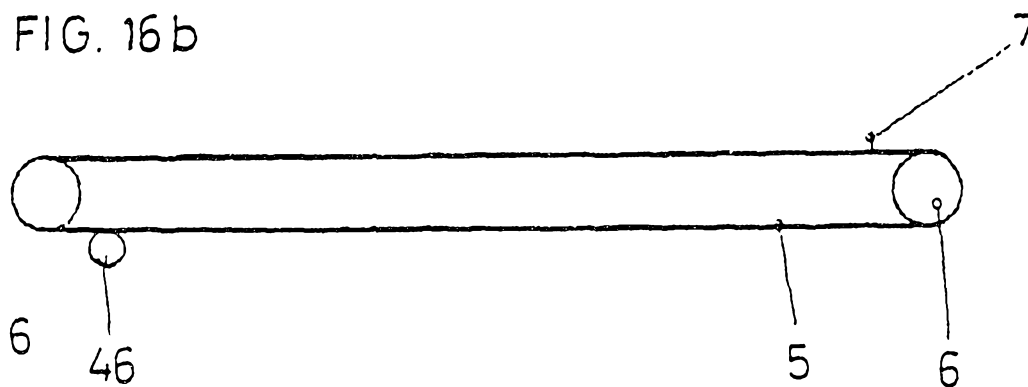

FIG. 16c

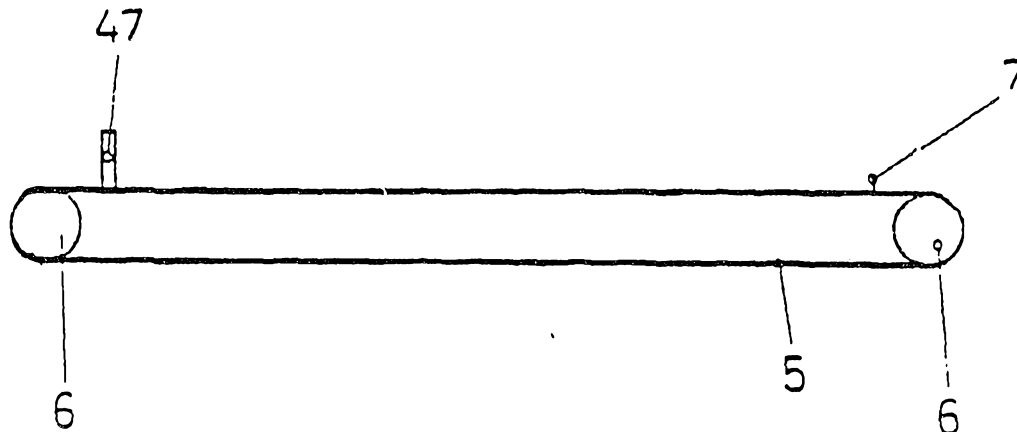

FIG. 17a

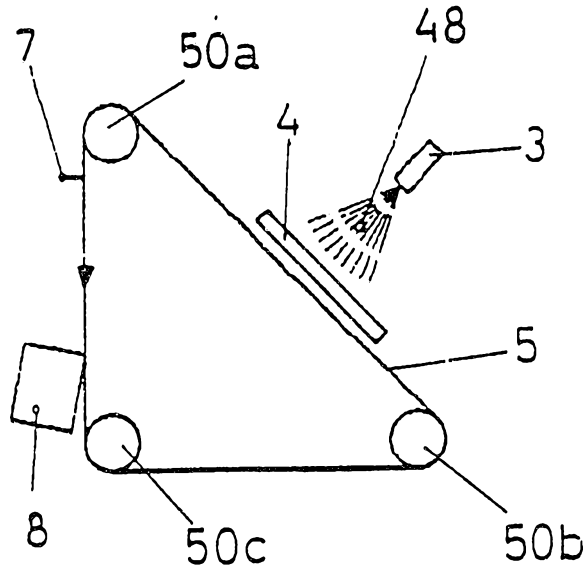

FIG. 17b

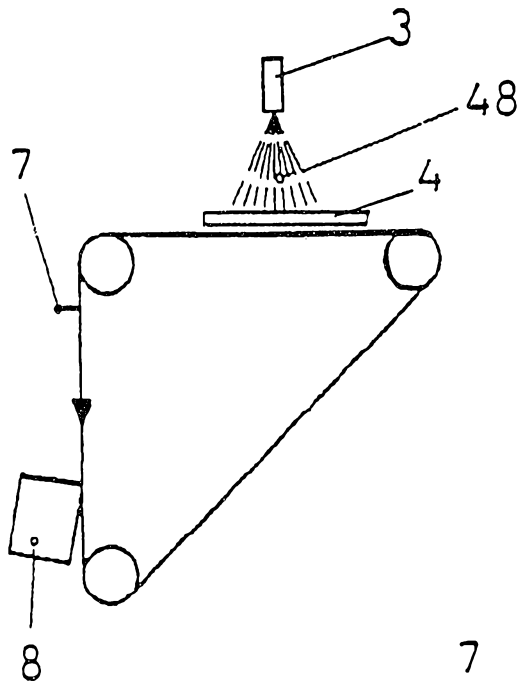

FIG. 17c

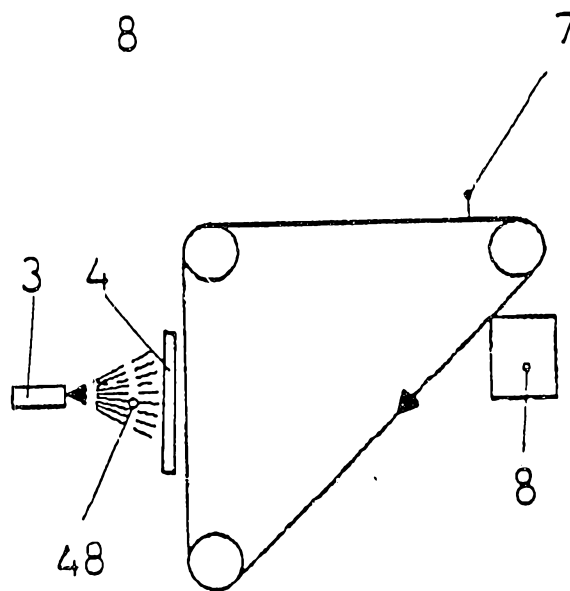
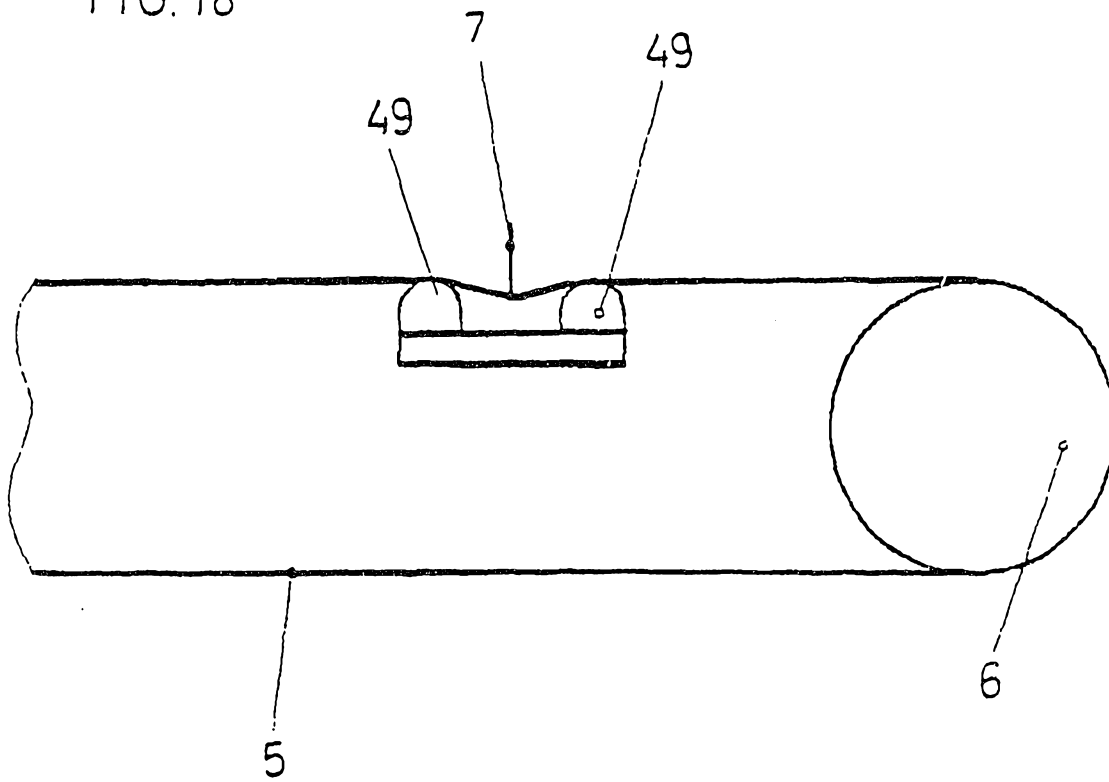

FIG. 18



INTERNATIONAL SEARCH REPORT

International application No.
PCT/AT 93/00048

A. CLASSIFICATION OF SUBJECT MATTER
IPC 5 B05B15/04; B05B15/12
According to International Patent Classification (IPC) or to both national classification and IPC

B. FIELDS SEARCHED
Minimum documentation searched (classification system followed by classification symbols)
IPC 5 B05B

Documentation searched other than minimum documentation to the extent that such documents are included in the fields searched

Electronic data base consulted during the international search (name of data base and, where practicable, search terms used)

C. DOCUMENTS CONSIDERED TO BE RELEVANT

| Category* | Citation of document, with indication, where appropriate, of the relevant passages | Relevant to claim No. |
|-----------|-------------------------------------------------------------------------------------------------------------------------------------------|-----------------------|
| X | PATENT ABSTRACTS OF JAPAN vol. 015, no. 145 (C-0823) 12 April 1991 & JP,A,30 26 370 (NORDSON KK) 4 February 1991 see abstract | 1,19,27 |
| A | FR,A,115 590 (TUNZINI AMELIORAIR) 7 July 1972 see page 3, line 6 - page 7, line 8; figures 1-4 | 1,3,19, 32 |
| A | EP,A,0 260 539 (KOPPERSCHMIDT-MUELLER GMBH & CO KG) 23 March 1988 see claims 1,2 | 1,2,18, 19 |
| A | DD,A,236 023 (VEB KOMBINAT ANLAGEN- UND GERATEBAU HALLE) 28 May 1986 see the whole document | 1,12,13, 15,25 |

Further documents are listed in the continuation of Box C. See patent family annex.

* Special categories of cited documents:
 "A" document defining the general state of the art which is not considered to be of particular relevance
 "E" earlier document but published on or after the international filing date
 "L" document which may throw doubts on priority claim(s) or which is cited to establish the publication date of another citation or other special reason (as specified)
 "O" document referring to an oral disclosure, use, exhibition or other means
 "P" document published prior to the international filing date but later than the priority date claimed
 "T" later document published after the international filing date or priority date and not in conflict with the application but cited to understand the principle or theory underlying the invention
 "X" document of particular relevance; the claimed invention cannot be considered novel or cannot be considered to involve an inventive step when the document is taken alone
 "Y" document of particular relevance; the claimed invention cannot be considered to involve an inventive step when the document is combined with one or more other such documents, such combination being obvious to a person skilled in the art
 "&" document member of the same patent family

Date of the actual completion of the international search: 29 October 1993 (29.10.93)
Date of mailing of the international search report: 05 November 1993 (05.11.93)

Name and mailing address of the ISA/
European Patent Office
Facsimile No.
Authorized officer
Telephone No.

ANNEX TO THE INTERNATIONAL SEARCH REPORT
ON INTERNATIONAL PATENT APPLICATION NO.

AT 9300048
SA 71080

This annex lists the patent family members relating to the patent documents cited in the above mentioned international search report.
The members are as contained in the European Patent Office EDP file on

The European Patent Office is in no way liable for these particulars which are merely given for the purpose of information. 29/10/93

| Patent document cited in search report | Publication date | Patent family member(s) | Publication date |
|----------------------------------------|------------------|-------------------------|------------------|
| FR-A-2115590 | 07-07-72 | None | |
| EP-A-0260539 | 23-03-88 | DE-A- 3631270 | 24-03-88 |
| | | JP-A- 63077563 | 07-04-88 |
| | | US-A- 4836137 | 06-06-89 |
| DD-A-236023 | | None | |

| I. KLASSIFIKATION DES ANMELDUNGSGEGENSTANDS (bei mehreren Klassifikationssymbolen sind alle anzugeben) ⁶ | | |
|-------------------------------------------------------------------------------------------------------------------------------------------------------------------------------------------------------------------------------------------------------------------------------------------------------------------------------------------------------------------------------------------------------------------------------------------------------------------------------------------------------------------------------------------------------------------------------------------------------------------------------------------------------------------------------------------------------------------------------------------------------------------------------------------------------------------------------------------------------------------------------------------------------------------------------------------------------------------------------------------------------------------------------------------------------------------------------------------------------------------------------------------------------------------------------------------------------------------------------------------------------------------------------------------------------------------------------------------------------------------------------------------------------------------------------------------------------------------------------------------------------------------------------------------------------------------------------------------------------------------------------------------------------------------------------------------------------------------------------------------------------------------------------------------------------------------------------------------------|--------------------------------------------------------------------------------------------------------------------------------------------------------|----------------------------------|
| Nach der Internationalen Patentklassifikation (IPC) oder nach der nationalen Klassifikation und der IPC | | |
| Int.Kl. 5 B05B15/04; B05B15/12 | | |
| II. RECHERCHIERTE SACHGEBIETE | | |
| Recherchierter Mindestprüfstoff ⁷ | | |
| Klassifikationssystem | Klassifikationssymbole | |
| Int.Kl. 5 | B05B | |
| Recherchierte nicht zum Mindestprüfstoff gehörende Veröffentlichungen, soweit diese unter die recherchierten Sachgebiete fallen ⁸ | | |
| | | |
| III. EINSCHLAGIGE VERÖFFENTLICHUNGEN ⁹ | | |
| Art. ^o | Kennzeichnung der Veröffentlichung ¹¹ , soweit erforderlich unter Angabe der maßgeblichen Teile ¹² | Betr. Anspruch Nr. ¹³ |
| X | PATENT ABSTRACTS OF JAPAN vol. 015, no. 145 (C-0823)12. April 1991 & JP,A,30 26 370 (NORDSON KK) 4. Februar 1991 siehe Zusammenfassung --- | 1,19,27 |
| A | FR,A,2 115 590 (TUNZINI AMELIORAIR) 7. Juli 1972 siehe Seite 3, Zeile 5 - Seite 7, Zeile 8; Abbildungen 1-4 --- | 1,3,19, 32 |
| A | EP,A,0 260 539 (KOPPERSCHMIDT-MUELLER GMBH & CO KG) 23. März 1988 siehe Ansprüche 1,2 --- | 1,2,18, 19 |
| | | -/-- |
| <p>^o Besondere Kategorien von angegebenen Veröffentlichungen ¹⁰ :</p> <p>"A" Veröffentlichung, die den allgemeinen Stand der Technik definiert, aber nicht als besonders bedeutsam anzusehen ist</p> <p>"E" älteres Dokument, das jedoch erst am oder nach dem internationalen Anmeldedatum veröffentlicht worden ist</p> <p>"L" Veröffentlichung, die geeignet ist, einen Prioritätsanspruch zweifelhaft erscheinen zu lassen, oder durch die das Veröffentlichungsdatum einer anderen im Recherchenbericht genannten Veröffentlichung belegt werden soll oder die aus einem anderen besonderen Grund angegeben ist (wie ausgeführt)</p> <p>"O" Veröffentlichung, die sich auf eine mündliche Offenbarung, eine Benutzung, eine Ausstellung oder andere Maßnahmen bezieht</p> <p>"P" Veröffentlichung, die vor dem internationalen Anmeldedatum, aber nach dem beanspruchten Prioritätsdatum veröffentlicht worden ist</p> <p>"T" Spätere Veröffentlichung, die nach dem internationalen Anmeldedatum oder dem Prioritätsdatum veröffentlicht worden ist und mit der Anmeldung nicht kollidiert, sondern nur zum Verständnis des der Erfindung zugrundeliegenden Prinzips oder der ihr zugrundeliegenden Theorie angegeben ist</p> <p>"X" Veröffentlichung von besonderer Bedeutung; die beanspruchte Erfindung kann nicht als neu oder auf erfinderischer Tätigkeit beruhend betrachtet werden</p> <p>"Y" Veröffentlichung von besonderer Bedeutung; die beanspruchte Erfindung kann nicht als auf erfinderischer Tätigkeit beruhend betrachtet werden, wenn die Veröffentlichung mit einer oder mehreren anderen Veröffentlichungen dieser Kategorie in Verbindung gebracht wird und diese Verbindung für einen Fachmann naheliegend ist</p> <p>"&" Veröffentlichung, die Mitglied derselben Patentfamilie ist</p> | | |
| IV. BESCHEINIGUNG | | |
| Datum des Abschlusses der internationalen Recherche | Absenddatum des internationalen Recherchenberichts | |
| 29. OKTOBER 1993 | 05. 11. 93 | |
| Internationale Recherchenbehörde | Unterschrift des bevollmächtigten Bediensteten | |
| EUROPÄISCHES PATENTAMT | JUGUET J.M. | |

| III. EINSCHLAGIGE VERÖFFENTLICHUNGEN (Fortsetzung von Blatt 2) | | |
|----------------------------------------------------------------|------------------------------------------------------------------------------------------------------------------|--------------------|
| Art ° | Kennzeichnung der Veröffentlichung, soweit erforderlich unter Angabe der maßgeblichen Teile | Betr. Anspruch Nr. |
| A | DD,A,236 023 (VEB KOMBINAT ANLAGEN- UND GERÄTEBAU HALLE) 28. Mai 1986 siehe das ganze Dokument ----- | 1,12,13, 15,25 |

**ANHANG ZUM INTERNATIONALEN RECHERCHENBERICHT
 ÜBER DIE INTERNATIONALE PATENTANMELDUNG NR.**

AT 9300048
 SA 71080

In diesem Anhang sind die Mitglieder der Patentfamilien der im obengenannten internationalen Recherchenbericht angeführten Patendokumente angegeben.

Die Angaben über die Familienmitglieder entsprechen dem Stand der Datei des Europäischen Patentamts am
 Diese Angaben dienen nur zur Unterrichtung und erfolgen ohne Gewähr.

29/10/93

| Im Recherchenbericht angeführtes Patendokument | Datum der Veröffentlichung | Mitglied(er) der Patentfamilie | Datum der Veröffentlichung |
|---------------------------------------------------|-------------------------------|-----------------------------------|-------------------------------|
| FR-A-2115590 | 07-07-72 | Keine | |
| EP-A-0260539 | 23-03-88 | DE-A- 3631270 | 24-03-83 |
| | | JP-A- 63077563 | 07-04-88 |
| | | US-A- 4836137 | 06-06-89 |
| DD-A-236023 | | Keine | |

EPO FORM P/473

Für nähere Einzelheiten zu diesem Anhang : siehe Amtsblatt des Europäischen Patentamts, Nr.12/82