

ADAMS & PECKOVER.

Cooking Stove.

No. 61,790.

Patented Feb. 5, 1867.

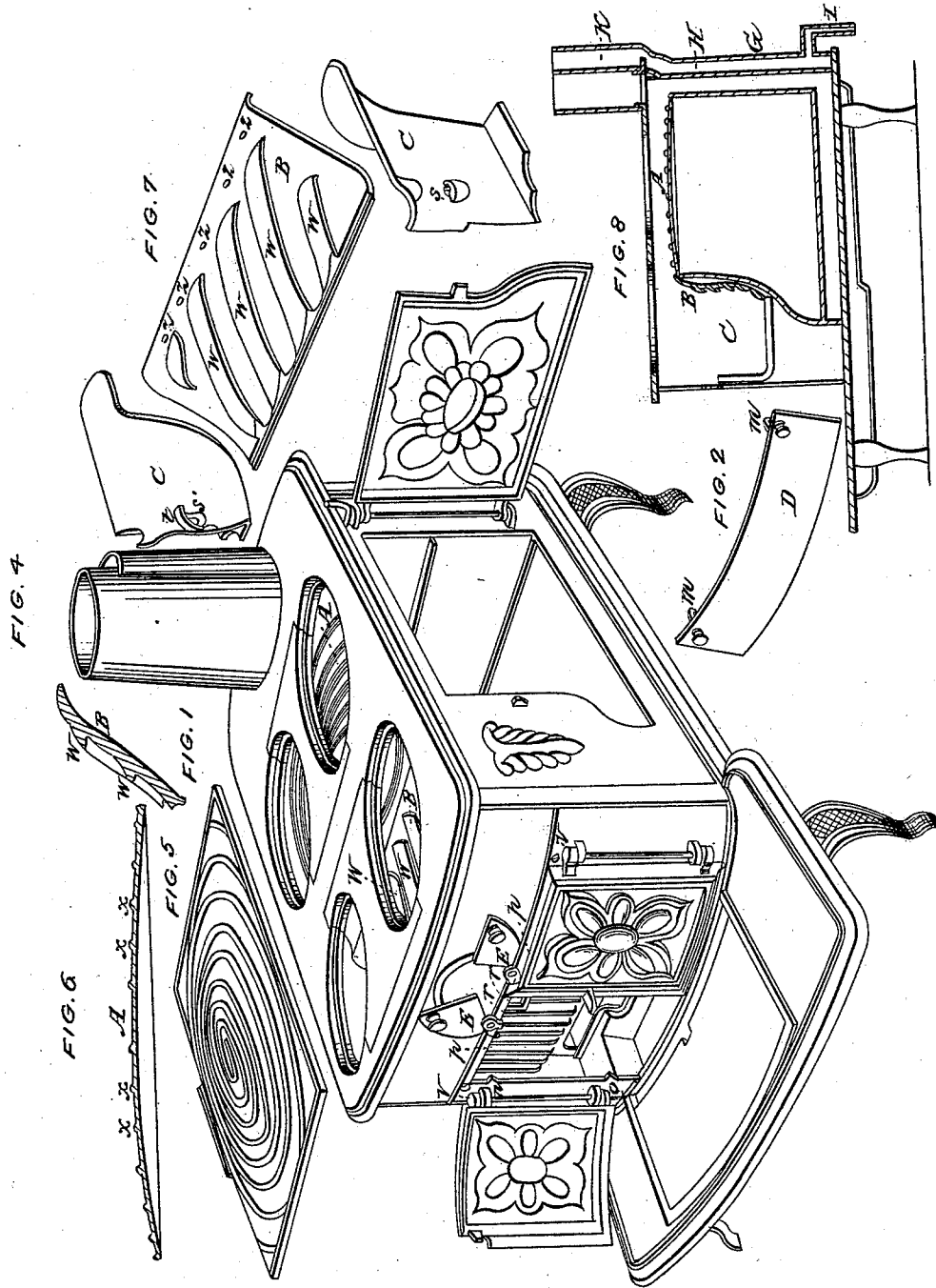

WITNESSES:

C. G. Hall
Stam. J. Fisher

INVENTORS:

Edmond C. Adams
Ralph Peckover

ADAMS & PECKOVER.

Cooking Stove.

No. 61,790.

Patented Feb. 5, 1867.

FIG. 3

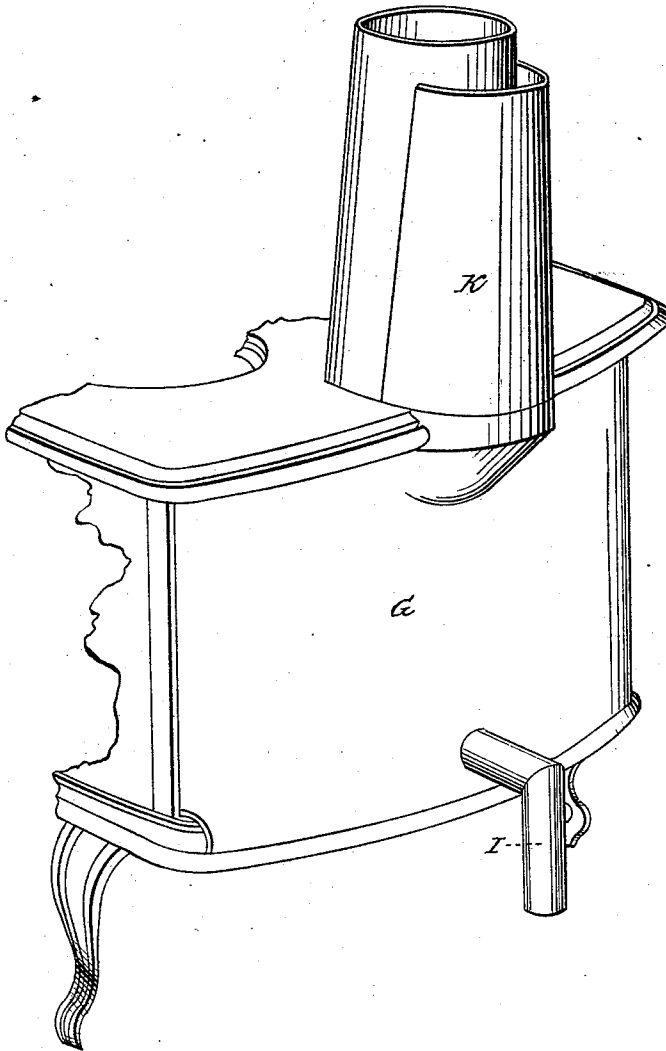

WITNESSES:

C. G. Hall
Wm. S. Peckover

INVENTORS:

Edmund Adams
Joseph Peckover

United States Patent Office.

FEDERAL C. ADAMS AND JOSEPH PECKOVER, OF CINCINNATI, OHIO.

Letters Patent No. 61,790, dated February 5, 1867.

IMPROVEMENT IN COOKING STOVES.

The Schedule referred to in these Letters Patent and making part of the same.

TO ALL WHOM IT MAY CONCERN:

Be it known that we, FEDERAL C. ADAMS and JOSEPH PECKOVER, of Cincinnati, in the county of Hamilton, and State of Ohio, have invented certain new and useful Improvements in Stoves; and we do hereby declare that the following is a full, clear, and exact description of the construction and operation of the same, reference being had to the annexed drawings, making a part of this specification, in which—

Figure 1 is a perspective view of a stove containing our improvements.

Figure 2 is a view of our combined duster and blower.

Figure 3 is a view of the back of the stove, showing the hot-air apparatus.

Figure 4 is a view in cross-section of the fire-back.

Figure 5 is a perspective view of the top plate of the oven.

Figure 6 is a longitudinal sectional view of the same.

Figure 7 is a perspective view of the plate forming the back and sides of the fire-chamber, detached.

Figure 8 is a longitudinal sectional view of the stove.

Like letters represent like parts in each of the figures.

Our improvements are as follows: First, we make the top plate of the oven slightly convex above and concave below, and strengthen it by a spiral rib cast upon the top, as shown in the drawings, in which the plate is marked A. It is shown in place in fig. 1, detached, and in perspective in fig. 5, and in section in figs. 6 and 8. The purpose of the curvature of the plate is to permit it to expand and contract upward and downward without cracking, while additional strength is imparted to it by the spiral rib *x x x*. Second, the fire-back is formed of a plate, having a space between it and the front of the oven, so that air may pass under the fire-back through this space and through the holes *z z z z* at the top, for the purpose of supplying oxygen for the combustion of the smoke and gas, and preventing the front of the oven from being overheated. The fire-back is also provided with projections or lips, *w w w*, running obliquely from top to bottom upon its front surface, and forming, by their overhanging edges, troughs or spouts for the passage of air from below to a point at or near the holes *z z z z*, thereby increasing the supply of oxygen without unduly cooling the oven. This front plate, which is marked B, is shown in perspective in figs. 1 and 7, and in section in figs. 4 and 8. It is made somewhat shorter than the space between the sides of the stove to permit it to expand freely in the direction of its length. The side pieces C C, fig. 7, are provided with curved flanges to cover the ends of the fire-back and keep it in place without the use of catches, and are also curved so as to form air spaces between themselves and the sides of the stove, into which air is admitted through the openings *v v*, and from which it is fed to the fire from the openings *s s*, protected by the overhanging lips *t t*. Third, the combined duster and blower D, fig. 2, is provided with catches or hooks, *m m*, which seize the projections on the opposite sides of the front of the stove. Two of these projections are near the top and two near the bottom, one of the top projections being shown at *n* and the other at *o*. When hooked by means of the top projections, the screen D acts as a blower for kindling the fire, and when attached to the projections at the bottom it acts as a duster to prevent ashes from flying into the room when the fire is poked or stirred. Fourth, the quadrant-shaped doors E E, at the front of the stove, are each hinged at one corner, as shown in fig. 1. Just below the corner is a projection, *p*, which, when the door is opened, strikes against the projection *r* on the stove and limits the movement. The latter projection also limits the movement of the door in closing. This arrangement avoids the difficulty of expansion and binding in sliding doors, and is much more manageable than doors hinged in the ordinary way. Fifth, the heating apparatus at the rear of the stove, formed by the additional plate G, figs. 1, 3, and 8, forming the space H, fig. 8, between such plate and the back plate of the stove. The air to be heated is fed to the heating chamber through the pipe I, and is conducted away for distribution through the pipe K, at the top.

Having thus described our improvements, what we claim as new and of our invention therein, and desire to secure by Letters Patent, is—

1. The concavo-convex oven top A, substantially as and for the purpose described.
2. The concavo-convex oven top A, in combination with the spiral strengthening rib or its equivalent, substantially as described.
3. The short fire-back B, with its air holes *z* and air tubes *w*, substantially as described.

4. The sides C C, with their flanges and air holes *v s*, in combination with the air passages on the sides of the stove, substantially as described.
5. The combined duster and blower D, in combination with the grate and the projections *n o*, or their equivalents, at the top and bottom of the front opening, substantially as described.
6. The quadrant-shaped doors E E, arranged, attached, and operating, substantially as described.
7. Holding the fire-back in place by the overlapping sides of the end lining plates, so as to dispense with the use of catches, and permit the fire-back to expand and contract freely, substantially as described.

FEDERAL C. ADAMS,
JOSEPH PECKOVER.

Witnesses:

E. G. HALL,
FRED. S. FISHER.