

W. B. SCAIFE.
Domestic Boiler.

No. 108,524.

Patented Oct. 18, 1870.

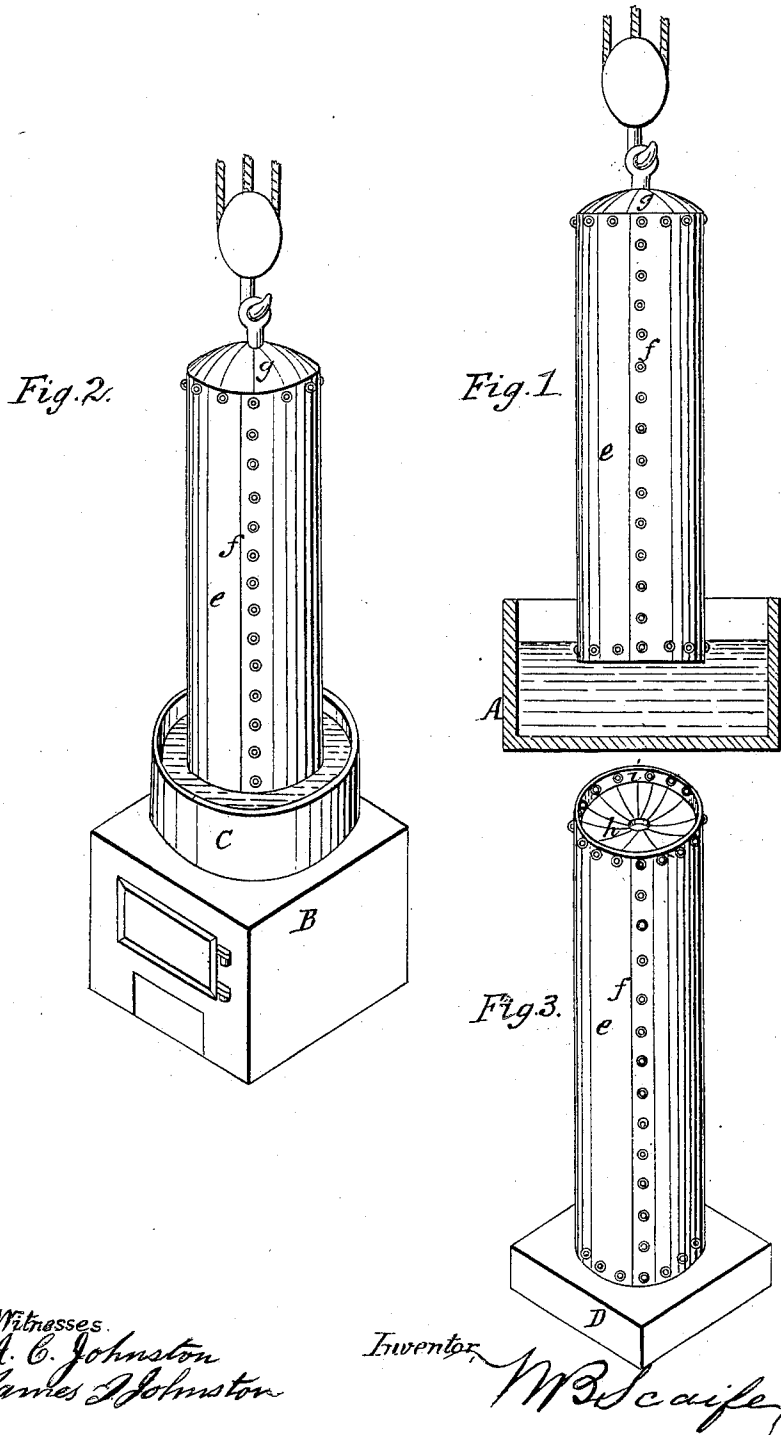

Witnesses.
A. C. Johnston
James Johnston

Inventor,
W. B. Scaife

UNITED STATES PATENT OFFICE.

WILLIAM B. SCAIFE, OF PITTSBURG, PENNSYLVANIA.

IMPROVEMENT IN KITCHEN-BOILERS.

Specification forming part of Letters Patent No. **108,524**, dated October 18, 1870.

To all whom it may concern:

Be it known that I, WILLIAM B. SCAIFE, of Pittsburg, in the county of Allegheny and State of Pennsylvania, have invented a new and useful Improvement in Kitchen-Boilers, the same being a new article of manufacture; and I do hereby declare the following is a full and exact description thereof, reference being had to the accompanying drawing, and to the letters of reference marked thereon.

The nature of my invention consists in making a new article of manufacture—viz., a kitchen-boiler having the ends first secured to it by means of rivets, and the joints around the rivets and the ends of the boiler subsequently immersed in a bath of muriate of zinc, and then in a bath of molten solder, and finally “soaking” the joints with soft solder, as hereinafter described.

To enable others skilled in the art to make and use my invention, I will proceed to describe my method of constructing kitchen-boilers.

In the accompanying drawing, which forms part of my specification, Figure 1 represents the boiler suspended so that the lower end of its shell and the flange of its bottom are immersed in a bath of muriate of zinc. Fig. 2 represents the boiler, after being removed from the bath of muriate of zinc, suspended and immersed in like manner in a bath of molten solder. Fig. 3 represents the boiler after being removed from the bath of molten solder, with its bottom end inverted for the purpose of closing the joint between the shell and flange of the bottom by what is known among tanners, plumbers, and gas-fitters as the “soaking process.”

In the accompanying drawing, A represents a bath of muriate of zinc, (zinc held in solution by muriatic acid.) B represents a furnace, provided with a vessel, C, for melting solder. D represents a block provided with a concavity for receiving the upper end of the boiler and holding it in an inverted position, as shown in Fig. 3.

The shell *e* of the boiler is constructed in the ordinary manner, except that the joint or seam *f* is riveted and then brazed. The dome-shaped head *g*, or other form of head, is then fitted and riveted to its place in the shell *e*. The bottom *h* is then fitted in, the shell marked and then removed from it, and openings for

the rivets punched in the flange *i*. After the several parts are thus constructed and prepared, the shell A and its head *g* are galvanized with zinc; also the bottom *h* and the rivets to be used for securing it in the shell.

After the several parts are galvanized, by the well-known art of galvanizing iron, the bottom *h* is riveted to its place in the shell A. The boiler is then suspended so that the lower end of the shell A and the flange *i* of the bottom *h* shall be immersed in a bath of muriate of zinc, as shown in Fig. 1. After remaining in this bath for one or two minutes it is removed from it, and jarring off the surplus of the muriate of zinc adhering to it, the same parts of the boiler are immersed in the molten solder, as shown in Fig. 2.

After remaining in the molten solder for a short time, the boiler is removed and inverted, as shown in Fig. 3. The operator then takes a stick of solder, and, placing one end of it on the joint or seam between the flange *i* and the shell *e*, moves it slowly around on the joint or seam, thereby melting the solder and soaking it into the joint or seam, through the medium of the heat which the parts acquired while immersed in the molten solder, thus making the boiler its own soldering-iron, for the purpose of forming a soaked joint or seam between the flange of the bottom and shell of the boiler.

By constructing kitchen-boilers by the method hereinbefore described, the manufacturer is enabled to make a cheap, durable, and perfectly steam-tight boiler without resorting to slow and vexatious process of calking and testing now in common use.

Having thus described the nature, construction, and advantages of my new article of manufacture and method for constructing kitchen-boilers, what I claim as my invention is—

A new article of manufacture—viz., a kitchen-boiler having the ends first secured in it by rivets, and the joints around the rivets and ends of the boiler subsequently immersed in a bath of muriate of zinc, and then in a bath of molten solder, and finally soaking the joints with soft solder, as herein described, and for the purpose set forth.

W. B. SCAIFE.

Witnesses:

A. C. JOHNSTON,
JAMES J. JOHNSTON.