

73136

M P Thatcher's

Imp: in Pad Locks

PATENTED
JAN 7 1868

Fig: 1

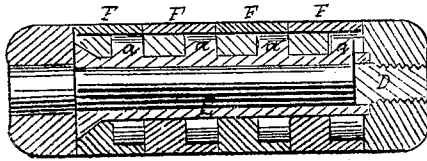

Fig: 2

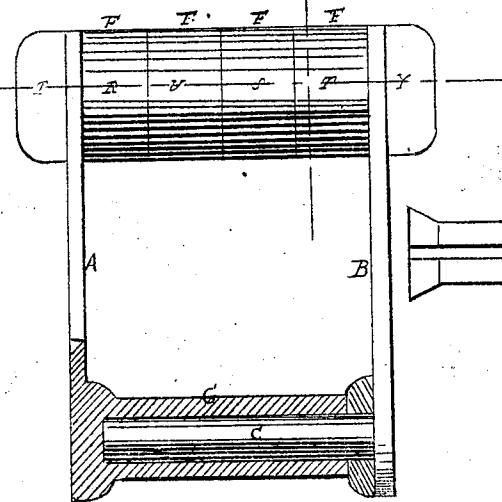
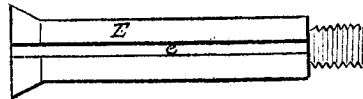

Fig: 3



Fig: 4



Witnesses
[Signature]
[Signature]

Inventor
M. P. Thatcher
per
Alexander & Masson
[Signature]

United States Patent Office.

M. P. THATCHER, OF PONTIAC, MICHIGAN.

Letters Patent No. 73,136, date January 7, 1868.

IMPROVEMENT IN PADLOCKS.

The Schedule referred to in these Letters Patent and making part of the same.

TO ALL WHOM IT MAY CONCERN:

Be it known that I, M. P. THATCHER, of Pontiac, in the county of Oakland, and in the State of Michigan, have invented certain new and useful Improvements in Padlocks; and do hereby declare that the following is a full, clear, and exact description thereof, reference being had to the accompanying drawings, and to the letters of reference marked thereon.

In the annexed drawings, making part of this specification, A and B represent two metallic plates, which form the side pieces of this lock. The plate A has upon its inner side, near each end, two hollow cylinders. G represents one, and E the other of these cylinders. The cylinder E has a long slot, *e*, running from one end of it to the other, and communicating with its centre opening. Surrounding the cylinder E is a series of wheels, F F, which fit loosely over and revolve upon it. The eye of each one of these wheels is provided with a cross-slot, the object of which will be described. The plate B is provided on its inner side, near each end, with two shafts, C and D. The shaft C fits snugly within the cylinder G of plate A. Shaft D is provided with a series of wings, *a a*, which, when the said shaft is inserted in cylinder E, project through the slot *e e* and between the wheels F F. Each of the wheels has a portion of the metal on one face turned away, leaving a socket or cup, and it is in these sockets that the wings *a a* rest. The wheels F are each provided on their peripheries with a series of letters, and one letter of each series is placed immediately over the cross-groove in the wheel, so as to indicate where the groove is. A mark is made upon each of the plates A and B, as seen at T and Y, which indicate the line of the groove in cylinder E, and also show on what line the letters on the wheels and over the cross-grooves should be placed. The letters R U S T, in this case, stand over the grooves in the wheels, and by arranging these letters in line with the letters T and Y, on the plates, the shaft D, with its wings, will draw out from cylinder E. Should one of the grooves in one of the wheels not be in line, the shaft D could not be drawn out. Those letters which indicate the direction of the grooves in the wheels, are of course the key to the lock, for without knowing these the lock cannot be opened.

Having thus fully described my invention, what I claim as new, and desire to secure by Letters Patent, is—

The arrangement of the plates A and B with their shafts and cylinders, as constructed and used, in combination with the wheels F F, as and for the purpose specified.

In testimony that I claim the foregoing, I have hereunto set my hand, this 31st day of August, 1867.

M. P. THATCHER.

Witnesses:

A. W. BURTT,
J. D. HOLMES.