

(12) STANDARD PATENT
(19) AUSTRALIAN PATENT OFFICE

(11) Application No. **AU 2006308435 B2**

(54) Title
Single or multiple stage blower and nested volute(s) and/or impeller(s) therefor

(51) International Patent Classification(s)
A61M 16/00 (2006.01) **F04B 17/00** (2006.01)
A61M 1/00 (2006.01)

(21) Application No: **2006308435** (22) Date of Filing: **2006.10.27**

(87) WIPO No: **WO07/048206**

(30) Priority Data

(31) Number	(32) Date	(33) Country
60/841,202	2006.08.31	US
60/775,333	2006.02.22	US
60/730,875	2005.10.28	US

(43) Publication Date: **2007.05.03**

(44) Accepted Journal Date: **2013.02.14**

(71) Applicant(s)
ResMed Limited

(72) Inventor(s)
Reed, Nicholas Jerome;Kenyon, Barton John;Smith, Ian Malcolm;Wilson, Andrew

(74) Agent / Attorney
Halfords IP, Level 7 1 Market Street, Sydney, NSW, 2000

(56) Related Art
WO 2004/108198
WO 2004/112873
US 2003/0168064
US 2001/0014290
US 5893705

(19) World Intellectual Property Organization
International Bureau



(43) International Publication Date
3 May 2007 (03.05.2007)

PCT

(10) International Publication Number
WO 2007/048206 A1

- (51) **International Patent Classification:**
A61M 16/00 (2006.01) F04B 17/00 (2006.01)
A61M 1/00 (2006.01)
- (21) **International Application Number:** PCT/AU2006/001617
- (22) **International Filing Date:** 27 October 2006 (27.10.2006)
- (25) **Filing Language:** English
- (26) **Publication Language:** English
- (30) **Priority Data:**
60/730,875 28 October 2005 (28.10.2005) US
60/775,333 22 February 2006 (22.02.2006) US
60/841,202 31 August 2006 (31.08.2006) US
- (71) **Applicant (for all designated States except US):** RESMED LTD [AU/AU]; 1 Elizabeth Macarthur Drive, Bella Vista, New South Wales 2153 (AU).
- (72) **Inventors; and**
- (75) **Inventors/Applicants (for US only):** KENYON, Barton, John [AU/AU]; C/- ResMed Ltd, 1 Elizabeth Macarthur Drive, Bella Vista, New South Wales 2153 (AU). REED, Nicholas, Jerome [AU/AU]; C/- ResMed Ltd, 1 Elizabeth Macarthur Drive, Bella Vista, New South Wales 2153 (AU). WILSON, Andrew [AU/AU]; C/- ResMed Ltd, 1 Elizabeth Macarthur Drive, Bella Vista, New South Wales 2153 (AU). SMITH, Ian, Malcolm [AU/AU]; C/- ResMed Ltd, 1 Elizabeth Macarthur Drive, Bella Vista, New South Wales 2153 (AU).
- (74) **Agents:** DAVIDSON, Geoffrey, Robert et al.; Halford & Co., 1 Market Street, Sydney, New South Wales 2000 (AU).
- (81) **Designated States (unless otherwise indicated, for every kind of national protection available):** AE, AG, AL, AM, AT, AU, AZ, BA, BB, BG, BR, BW, BY, BZ, CA, CH, CN, CO, CR, CU, CZ, DE, DK, DM, DZ, EC, EE, EG, ES, FI, GB, GD, GE, GH, GM, GT, HN, HR, HU, ID, IL, IN, IS, JP, KE, KG, KM, KN, KP, KR, KZ, LA, LC, LK, LR, LS, LT, LU, LV, LY, MA, MD, MG, MK, MN, MW, MX, MY, MZ, NA, NG, NI, NO, NZ, OM, PG, PH, PL, PT, RO, RS, RU, SC, SD, SE, SG, SK, SL, SM, SV, SY, TJ, TM, TN, TR, TT, TZ, UA, UG, US, UZ, VC, VN, ZA, ZM, ZW.
- (84) **Designated States (unless otherwise indicated, for every kind of regional protection available):** ARIPO (BW, GH, GM, KE, LS, MW, MZ, NA, SD, SL, SZ, TZ, UG, ZM, ZW), Eurasian (AM, AZ, BY, KG, KZ, MD, RU, TJ, TM), European (AT, BE, BG, CH, CY, CZ, DE, DK, EE, ES, FI, FR, GB, GR, HU, IE, IS, IT, LT, LU, LV, MC, NL, PL, PT, RO, SE, SI, SK, TR), OAPI (BF, BJ, CF, CG, CI, CM, GA, GN, GQ, GW, ML, MR, NE, SN, TD, TG).
- Declaration under Rule 4.17:**
— of inventorship (Rule 4.17(iv))

[Continued on next page]

(54) **Title:** SINGLE OR MULTIPLE STAGE BLOWER AND NESTED VOLUTE(S) AND/OR IMPELLER(S) THEREFOR

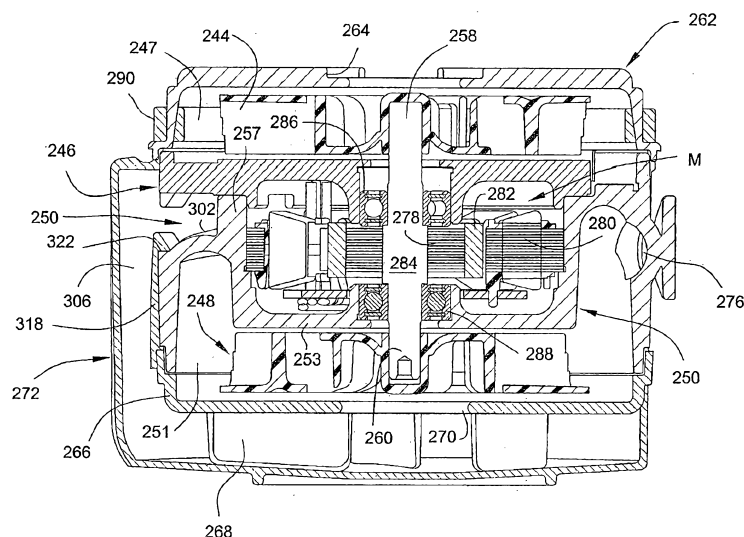

(57) **Abstract:** A single ended or double-ended blower comprising a blower motor assembly (M) supporting opposed first (258) and second (260) shaft ends, the first (258) and second (260) shaft ends having respective first (244) and second (248) impellers attached thereto and enclosed within first (247) and second (251) volutes, respectively, wherein the first volute (247) is connected to an inlet (264) and the second volute (251) is connected to an outlet (276); and the blower motor assembly (M) supported in a chassis enclosure (238); a radially outer inter-stage path between the first (247) and second (251) volute, wherein the second (251) volute is at least partially substantially concentrically nested with the radially outer inter-stage gas path.

WO 2007/048206 A1



Published:

— with international search report

For two-letter codes and other abbreviations, refer to the "Guidance Notes on Codes and Abbreviations" appearing at the beginning of each regular issue of the PCT Gazette.

TITLE OF THE INVENTION

SINGLE OR MULTIPLE STAGE BLOWER AND NESTED VOLUTE(S) AND/OR
IMPELLER(S) THEREFOR

CROSS REFERENCE TO PRIORITY APPLICATIONS

[0001] This application claims the benefit of U.S. Provisional Application No. 60/730,875, filed October 28, 2005, U.S. Provisional Application No. 60/841,202, filed August 31, 2006 and U.S. Provisional Application No. 60/775,333, filed February 22, 2006, each incorporated herein by reference in its entirety.

BACKGROUND OF THE INVENTION

1. Field of the Invention

[0002] The present invention relates to an apparatus for supplying breathable gas to a human, used in, for example, Continuous Positive Airway Pressure (CPAP) treatment of Obstructive Sleep Apnea (OSA), other respiratory diseases and disorders such as emphysema, or the application of assisted ventilation.

2. Description of Related Art

[0003] CPAP treatment of OSA, a form of Noninvasive Positive Pressure Ventilation (NIPPV), involves the delivery of a pressurized breathable gas, usually air, to a patient's airways using a conduit and mask. Gas pressures employed for CPAP can range, e.g., from 4 cm H₂O to 30 cm H₂O (typically in the range of 8-15 cmH₂O), at flow rates of up to 180 L/min (measured at the mask), depending on patient requirements. The pressurized gas acts as a pneumatic splint for the patient's airway, preventing airway collapse, especially during the inspiratory phase of respiration.

[0004] Typically, the pressure at which a patient is ventilated during CPAP is varied according to the phase of the patient's breathing cycle. For example, the ventilation apparatus may be pre-set, e.g., using control algorithms, to deliver two pressures, an inspiratory positive airway pressure (IPAP (e.g., 4-8 cmH₂O)) during the

inspiration phase of the respiratory cycle, and an expiratory positive airway pressure (EPAP (e.g., 10-20 cmH₂O)) during the expiration phase of the respiratory cycle. An ideal system for CPAP is able to switch between IPAP and EPAP pressures quickly, efficiently, and quietly, while providing maximum pressure support to the patient during the early part of the inspiratory phase.

[0005] In a traditional CPAP system, the air supply to the patient is pressurized by a blower having a single impeller, i.e., a single stage blower. The impeller is enclosed in a volute, or housing, in which the entering gas is trapped while pressurized by the spinning impeller. The pressurized gas gradually leaves the volute and travels to the patient's mask, e.g., via an air delivery path typically including an air delivery tube.

[0006] Other blowers utilize a pair of impellers with, for example, one on either side of the motor but fixed to a common output shaft. Such configurations are disclosed in commonly-owned U.S. Patent No. 6,910,483 and in commonly-owned co-pending application Serial No. 10/864,869, filed June 10, 2004, each incorporated herein by reference in its entirety.

[0007] Single-stage blowers are often noisy and are not as responsive as two-stage blowers in that they require longer periods of time to achieve the desired pressure. Two-stage blowers tend to generate less noise since they can run at lower speeds to generate the desired pressure, and are more responsive. On the other hand, two stage or double-ended blowers tend to be too large for certain applications.

SUMMARY OF THE INVENTION

[0008] One aspect of the present invention relates generally to a single or multiple stage, e.g., two or more stages, variable-speed blower assembly that provides faster pressure response time with increased reliability and less acoustic noise, and in a smaller package.

[0009] Another aspect of the present invention relates to an impeller for use with a blower assembly for the treatment of sleep disordered breathing.

[0010] To this end, the exemplary embodiments described herein have various structural aspects that are particularly advantageous. One aspect relates to the blower motor assembly, and specifically, to the elimination of a typical motor housing, thus reducing both size and weight. With the elimination of the motor housing, the space between the motor body and the chassis in which the motor body is supported, defines the first volute for pressurized air between the first and second stage impellers.

[0011] In an embodiment, an annular dividing seal between the motor body and chassis divides the substantially radial space into two portions. A first or upper portion houses the upper half of the blower motor assembly and includes a gas inlet for supplying unpressurized gas to a first stage impeller located at the upper end of the motor. The second or lower portion houses the lower half of the blower motor assembly and includes the first volute and a second gas inlet to a second stage impeller located at the lower or opposite end of the motor. In other words, a first volute in the upper portion supplies gas to the second inlet at the second stage impeller by means of an inter-stage path, and a second volute located within the motor body, and axially beneath the first volute, moves the air to the chassis outlet. This axially nested arrangement of the volutes and the inter-stage path provides significant space savings.

[0012] Another structural aspect of an exemplary embodiment relates to the support of the blower motor assembly on a plurality of springs within the chassis, providing vibrational isolation of the blower motor assembly from the chassis. Another related feature is the utilization of a plastic material for the blower motor assembly top cover; a relatively soft, flexible polymer, such as silicone rubber, for both the dividing seal between the blower motor assembly and chassis and for the coupling between the blower motor assembly outlet and the chassis outlet; and metals such as aluminum or magnesium for the motor cap and motor body. The combination of dissimilar materials for various component parts tends to damp out vibration and thus reduce noise.

[0013] In order to reduce inertia and thus enhance responsiveness in terms of pressure variations, the first and second stage impellers are of the double-shroud type, but the pair of shrouds on the respective impellers are not identical. Rather, one shroud

extends from a center hub of the impeller a relatively short distance in a radially outward direction. The other shroud extends radially outwardly to the outer edges of the impeller blades, but with a center opening having an inner diameter similar to the outer diameter of the smaller shroud. This configuration, sometimes referred to herein as an “alternating shroud” configuration, facilitates manufacture and reduces inertia by reducing the amount of material in the outer portion of the impeller, without sacrificing impeller rigidity requirements. This approach also reduces the sensitivity to variations in the gap between impeller and cover.

[0014] In another embodiment, nested volutes components are fastened together about the blower motor, and are at the same time sandwiched between upper and lower lids or covers that may be snap-fit onto (or otherwise suitably attached to) the respective volutes components, providing an axially compact and easily assembled unit. This assembly is also adapted to be received in a cup-shaped, open-ended flexible sleeve.

[0015] The impeller vanes or blades are continuously curved in a radial direction, but also taper in width in the radially outer portions, along edges adjacent the smaller-diameter shroud. Moreover, the outermost transverse edges of the blades or vanes may be stepped along their respective transverse widths. This design reduces turbulence noise at the tips of the blades and in addition, the impellers are preferably made of a polypropylene rather than the conventional polycarbonate so as to provide even further acoustic damping properties.

[0016] In an alternative embodiment, the larger diameter shroud may have a truncated frusto-conical shape, with a corresponding taper along one edge of the impeller blades in a radial length direction, such that at least the radially outer portions of the blades taper in width in a radially outer direction.

[0017] Another feature relates to having a matching taper along an adjacent surface of the one or both of the top and bottom lids or covers to provide a substantially constant distance between the tapered blade edges and adjacent lid or cover surfaces.

[0018] Preferably, the first and second stage impellers are secured at opposite ends of the motor output shaft for rotation about a common axis. The impellers are placed in fluid communication with one another by the gas flow path such that they cooperatively pressurize gas in the first and second volutes before exiting the chassis outlet.

[0019] Accordingly, in one aspect, the invention relates to a double-ended blower comprising a blower motor assembly supporting opposed first and second shaft ends, the first and second shaft ends having respective first and second impellers attached thereto and enclosed within first and second volutes, respectively, wherein the first volute is connected to an inlet and the second volute is connected to an outlet; and the blower motor assembly supported in a chassis enclosure; a radially outer inter-stage path between the first and second volute, wherein the second volute is at least partially substantially concentrically nested with the radially outer inter-stage gas path.

[0020] In another aspect, the invention relates to a double-ended blower comprising a blower motor assembly supporting opposed first and second shaft ends, the first and second shaft ends having respective first and second impellers attached thereto; the blower motor assembly supported within a chassis enclosure and comprising a motor body including a bottom wall, a peripheral sidewall and a top cover and wherein the top cover is provided with a flexible seal that engages an inner wall of the chassis enclosure.

[0021] In another aspect, the invention relates to a blower comprising a blower motor assembly supporting a shaft with a shaft end provided with an impeller, said impeller having a plurality of curved vanes, each vane tapering in width in radially outer portions thereof.

[0022] Another aspect of the invention is directed to an impeller comprising a top shroud; a bottom shroud; and a plurality of vanes extending from the top shroud to the bottom shroud, each said vane including a top edge at a radially inner portion of the vane in contact with the top shroud and a bottom edge at a radially outer portion of the vane in contact with the bottom shroud, such that a radially inner portion of the vane at

the bottom edge of each vane is not in contact with or adjacent the bottom shroud and a radially outer portion of the vane at the top edge of each vane is not in contact with or adjacent the top shroud.

[0023] In still another aspect, the invention relates to a double-ended blower comprising: a blower motor including oppositely extending first and second shaft ends, supporting first stage and second stage impellers, respectively; first and second volute components on opposite sides of the motor and secured to each other; an upper lid or cover attached to the first volute and a lower lid or cover attached to the second volute, the first volute component and the upper lid or cover defining a first volute in which the first stage impeller is mounted, the second volute component and the lower lid or cover defining a second volute in which the second impeller is mounted, the first and second volutes connected by a spiral inter-stage gas path substantially concentric with the first and second shaft ends.

[0024] These and other aspects will be described in or apparent from the following detailed description of preferred embodiments.

BRIEF DESCRIPTION OF THE DRAWINGS

[0025] FIGURE 1 is a perspective view of a blower motor assembly in accordance with the first exemplary embodiment of the invention;

[0026] FIGURE 2 is a perspective view of the blower motor assembly of Figure 1, but rotated in a counter-clockwise direction about, a vertical center axis of the assembly approximately 90°;

[0027] FIGURE 3 is another perspective view of the blower motor assembly as shown in Figure 1, but with a top cover of the assembly removed;

[0028] FIGURE 4 is a perspective view of a blower motor assembly in accordance with another exemplary embodiment of the invention;

[0029] FIGURE 5 is a an exploded perspective view illustrating the blower motor assembly of Figure 4 in combination with a chassis;

[0030] FIGURE 6 is a perspective view similar to Figure 5, but with the blower motor assembly inserted within the chassis;

[0031] FIGURE 7 is a cross-section taken along the line 7-7 of Figure 6;

[0032] FIGURE 8 is a perspective view of an impeller of the kind incorporated into the blower motor assemblies shown in Figures 1 and 4;

[0033] FIGURE 9 is a perspective view of the opposite side of the impeller shown in Figure 8;

[0034] FIGURE 10 is a section taken through line 10-10 of Figure 9;

[0035] FIGURES 10-1 to 10-6 are views of an impeller according to another embodiment of the present invention;

[0036] FIGURES 10-7 to 10-10 are views of the impeller with three alternative embodiments of the chamfering of the vane or blade tips;

[0037] FIGURE 11 is a perspective view, partially in section, of the blower motor assembly and chassis, similar to Figure 6 but with a top lid placed over the chassis, and with part of the chassis and first stage impeller removed;

[0038] FIGURE 12 is a view of the blower motor assembly and chassis of Figure 11, but from a slightly different perspective, and with supporting springs removed for clarity sake;

[0039] FIGURE 13 is a sectional view similar to Figure 12 but with the blower motor assembly sectioned as well;

[0040] FIGURE 14 is a plan view of the chassis, with the chassis lid and blower motor assembly removed;

[0041] FIGURE 15 is a bottom plan view of the blower motor assembly shown in Figure 4;

[0042] FIGURE 16 is a perspective view of a flexible sleeve for use with a blower motor assembly in accordance with another embodiment;

[0043] FIGURE 17 is a top plan view of the sleeve shown in Figure 16;

[0044] FIGURE 18 is a side elevation of the sleeve shown in Figure 17, sectioned along line 18;

[0045] FIGURE 19 is a bottom plan view of the sleeve shown in Figure 16;

[0046] FIGURE 20 is a perspective view, partially cut away, of the sleeve of Figure 16 assembled over a blower motor assembly;

[0047] FIGURE 21 is a cross-section of a blower motor and sleeve assembly located within a chassis enclosure; and

[0048] FIGURE 22 is a partial perspective of a variation of the flexible sleeve shown in Figures 16-21.

[0049] FIGURE 23 is an exploded assembly view of a blower motor assembly in accordance with another embodiment;

[0050] FIGURE 24 is a section view of the assembled blower motor assembly of Figure 23;

[0051] FIGURE 25 is a perspective view of a first volute component used in the embodiment illustrated in Figures 23 and 24;

[0052] FIGURE 26 is a perspective view of assembled first and second volute components from the embodiment illustrated in Figures 23 and 24;

[0053] FIGURE 27 is a perspective view of the assembly of Figure 26 but in an inverted position;

[0054] FIGURE 28 is another perspective view of the assembled first and second volute components shown in Figures 26 and 27;

[0055] FIGURE 29 is a perspective view similar to that shown in Figure 28 but rotated approximately 180°;

[0056] FIGURE 30 is a perspective view similar to Figure 28 but with the assembled components rotated slightly in a counterclockwise direction and tilted to a more upright position;

[0057] FIGURE 31 is a perspective view of the top lid or cover taken from Figure 23;

[0058] FIGURE 32 is a perspective view of the top lid or cover of Figure 31, but with the lid or cover in an inverted position;

[0059] FIGURE 33 is a perspective view of the bottom lid or cover taken from Figure 23;

[0060] FIGURE 34 is a bottom plan view of the bottom lid or cover shown in Figure 33;

[0061] FIGURE 35 is a perspective view of a flexible sleeve taken from Figure 23; and

[0062] FIGURE 36 is a another perspective view of the sleeve shown in Figure 23.

DETAILED DESCRIPTION OF ILLUSTRATED EMBODIMENTS

a) General

[0063] Referring initially to Figures 1, 2 and 3, a blower motor assembly 10 in accordance with an exemplary embodiment generally includes a motor body 12 having a top cover 14 and a bottom cover 16. The motor itself is of conventional design and

therefore need not be described in detail, other than to note that an output shaft (represented by center axis 48 in Figure 7) projects from opposite upper and lower ends of the motor but does not extend through the top and bottom covers 14, 16 of the assembly. In this regard, it should be understood that references herein to terms such as "upper," "lower," "top" and "bottom," etc. are for convenience only as viewed in connection with the drawings, and are not intended to be limiting in any way.

[0064] A gas inlet opening 18 is provided in the top cover 14 and a gas outlet 20 is provided in a side wall of the motor housing 12. A power cable 22 extends from the motor body for connection to a power source.

[0065] Before describing the blower motor assembly 10 in detail, reference is made to Figures 5-7 and 11-14 that illustrate a chassis enclosure (or simply, chassis) 24 that is adapted to receive the blower motor assembly 10. More details of the chassis 24 can be found in U.S. Patent Application No. 10/533,840, filed May 4, 2005, incorporated herein by reference in its entirety. More specifically, the blower motor assembly may be supported on a bottom wall 26 of the chassis 24 via a plurality of coil springs 28 (one shown in Figures 1, 2). Three such springs are employed in the exemplary embodiment but the number and arrangement of such springs may vary. Springs 28 are seated in pockets or recesses 30 (see Figures 5 and 14) formed in the bottom wall 26 of the chassis 24, with the upper ends of the springs engaged in aligned similar pockets or recesses 31 in the underside of the bottom cover 16 of the blower motor assembly 10 (see Figure 15).

[0066] A gas inlet conduit 32 in chassis 24 (see Figure 7) supplies gas to the blower motor assembly 10, while gas outlet tube 34 connects to the gas outlet opening 20 of the blower motor assembly 10 when the latter is fully seated in the chassis.

[0067] The blower motor assembly 10 is preferably not enclosed within a typical outer motor enclosure or housing. As a result, the blower motor body 12 (Figures 1-3) itself is able to be installed within a smaller chassis, while maintaining a necessary gap between the motor body 12 and the peripheral side wall 36 of the chassis 24 for establishing the first-to-second stage gas path (as explained in further detail below). Note

that wall 36 of the chassis 24 may be of double-wall construction (Figure 7) or of single-wall construction (Figures 11-13). By supporting the blower motor assembly 10 on springs 28 (or other suitable vibration damping components), and spaced from the peripheral side wall 36 and lid 38 of the chassis, the blower motor is vibrationally isolated from the chassis 24.

[0068] Upon insertion of the blower motor assembly 10 into the chassis 24, a chassis lid 38 (Figures 7 and 11-13) is located over the blower motor assembly, closing the upper open end of the chassis.

[0069] With this general description in mind, the components as well as the operation of the device will now be described in greater detail.

b) Blower Motor Assembly

[0070] It should be noted here that the blower motor assembly 10 shown in Figures 1-3 is slightly different from the blower motor assembly 110 of Figures 4-7 and 11-14. The assembly shown in Figures 1-3 is shown with various details, some of which are related to manufacturing considerations that may or may not appear in the assembly shown in Figures 4-7 and 11-14 and vice versa, particularly with respect to the blower motor body, top cover and bottom cover. In this regard, the external component of the blower motor assembly in Figures 4-7 and 11-14 are designated by similar reference numbers as used in Figures 1-3, but with the prefix "1" added. To this extent, assemblies 10 and 110 may be considered different embodiments although they are similar in terms of overall configuration and function. In addition, and, for purposes of this disclosure, the internal components of blower motor assemblies 10 and 110 should be considered substantially identical.

[0071] With particular reference to Figures 7 and 11-13, the blower motor assembly 110 includes a motor body 112 formed with an interior chamber 40 defined by a bottom wall 42 of the body 112, an inner side wall 44 and a motor cap or end bell 46. The motor coil and armature (omitted for clarity) are secured within the motor body 112 in conventional fashion and an output shaft, shown schematically at 48, extends in

opposite directions through the motor cap 46 and the bottom wall 42 of the body 112. The cap 48 and the bottom wall 42 may include suitable bearing supports for the shaft. Note that the motor cap 46 engages an upper peripheral edge 52 of the motor body 112 and, via lateral flange 54 and vertical lip 56, engages an internal shoulder 58 of the top cover 114. The space 60 (also referred to herein as the "first volute") between the motor cap 46 and the blower motor assembly top cover 114 is occupied by the first stage impeller 62 that is secured to the upper end of the motor output shaft 48 via a center hub or bushing 50.

[0072] The blower motor body 112 is also formed with a depending skirt or outer wall 64 that is connected at its upper end to the inner side wall 44 by a generally horizontal flange 66. The flange 66 and thus the upper end of the outer wall 64 spirals downwardly about the inner side wall 44, forming the second stage volute (described further herein)--while the lower end of the outer wall 64 is engaged by the blower motor assembly bottom cover 116 by a telescoping fit indicated at 68. The space 70 (also referred to herein as the "second volute") between the bottom cover 116 and the bottom wall 42 of the blower motor body 112 is occupied by a second stage impeller 72 that is secured to the lower end of the motor output shaft 48 via a center hub or bushing 75. The blower motor body 112 and cap 46 are preferably made of aluminum or other suitable heat conducting material for good thermal conduction, such as magnesium. The heat conducting material can help to convectively cool the motor and has good heat transfer characteristics. In addition, the heat taken away from the motor can be applied to heat the pressurized gas traveling to the patient, e.g., via the air delivery tube. Alternatively, the heat can simply be diverted away from the motor and the air delivery tube.

[0073] The top cover 114 of the blower motor assembly includes upper and lower portions 74, 76, respectively. The upper portion may be constructed of a relatively rigid plastic or other suitable lightweight material and has a generally inverted cup-shape, with a center opening or aperture 118 through which air is supplied to the first stage impeller 62. The lower portion 76 of the top cover is in the form of a depending skirt, attached to the upper portion 74 adjacent the shoulder or edge 58 by adhesive or any other suitable means. The lower portion 76 is preferably constructed of a flexible

polymer or rubber material (e.g., silicone rubber) that enables the top cover 114 to seal against the inner peripheral wall 36 of the chassis 24 at 78. The significance of this sealing arrangement will be described further below.

[0074] The gas outlets 20 and 120, respectively, of the blower motor assemblies 10 and 110 are also formed of a flexible material, such as silicone rubber. This results in a flexible sealed connection to the chassis gas outlet tube 34 when the blower motor assemblies 10 or 110 are inserted and properly oriented within the chassis 24. The gas outlets 20, 120 each include an outer oval-shaped peripheral rim 82, 182 and an inner, round rim 84, 184 define the outlet openings 86, 186 and that, respectively, are adapted to engage complimentary surfaces on the inner wall of the chassis 24, with rims 84, 184 specifically designed to be sealably engaged by the round outlet tube 34 of the chassis.

c) Impellers

c1) First Embodiment – Alternating Double Shroud Impeller

[0075] The first and second stage impellers 62, 72 may be identical in design (though must be of mirrored geometry to suit the present embodiment) and, accordingly, only the impeller 62 will be described in detail. With particular reference to Figures 8-10, impeller 62 is of one-piece molded plastic construction, although other suitable materials and manufacturing techniques could be employed. The impeller 62 comprises a plurality of continuously curved or straight vanes or blades 88 sandwiched between a pair of disk-like shrouds 90, 92. The smaller shroud 92 incorporates the hub or bushing 50 that receives the upper end of the motor shaft 48. The shroud 92 overlaps an inner portion of the vanes 88, i.e., the outer diameter (OD) of the smaller shroud is substantially smaller than the OD of the larger shroud 90. The latter is formed with a relatively large center opening 94, but this shroud extends to the radially outer tips of the vanes. Making the OD of the smaller shroud 92 slightly smaller than the diameter of the center opening 94 in shroud 90, facilitates the molding process used to manufacture the impellers (by allowing the impeller to be easily moulded in one piece).

[0076] By utilizing the differentially sized shrouds (specifically by having only one shroud in the outer portion of the impeller), the inertia of the impellers 62, 70 is reduced while the overall rigidity of the impellers is maintained. In this regard, both impellers 62, 72 are preferably constructed of a polycarbonate or polypropylene material (the latter of which provides acoustic dampening properties that dampen the resonance of the impellers). Glass fibre reinforcement may be employed to increase the stiffness of the polypropylene or polycarbonate if required.

[0077] The radially outer portions 96 of the vanes or blades 88 taper in width and the transverse tip edges 98 may be stepped, as best seen in Figure 10. Each vane may have a profile appropriate for the intended goal and such profile may be tapered. For example, each vane may taper in plan view (i.e., the edge thickness of each vane may taper from a larger width to a narrower width from inside to outside), and/or each vane may taper in elevation view (i.e., the height of each vane along the length may taper from a larger height to a smaller height from inside to outside). This may be achieved by tapering the vane or blade edges adjacent the smaller-diameter shroud so that at least the radially outer portion of the blade tapers to a reduced width at the radially outer end of the impeller. In addition, the cross-section thickness of the vanes may be variable or tapered. These vane features are intended to reduce noise, and the stepped specifically function to break up pressure pulses around the tips of the vanes. In alternative embodiment the trailing edges of the impeller blades may be disrupted by other disturbances, such as but not limited to dimpling or roughening. Such disturbances break up the smooth flow of air trailing off the blade edges and assist in reducing noise.

[0078] In one embodiment, illustrated in Figures 10-7 to 10-9, the tip of the impellers between the edge surface 88.3 which extends beyond the smaller shroud 92 and the transverse tip edges 98 is chamfered or notched to create a transition surface 99 at the tip. Examples of this transition surface include a straight chamfer 99.1 (Figures 10-7), a convex chamfer, for example arcuate 99.2 (Figure 10-8), or a concave notch 99.3 (Figures 10-9).

[0079] The chamfer or notch dimension is preferably between 0.5-5 mm along each edge (98 and 88.3), more preferably about 2 mm, from the notional corner that is

formed by extending the planes of the transverse tip edges 98 and the edge surfaces 88.3 to intersect, as shown in Figure 10-10. The dimension along each edge is not required to be the same.

[0080] The chamfering or notching of the blade as described is intended to further reduce noise, including decreasing the blade passing tones.

[0081] The exterior or outer surfaces of the bottom covers 16, 116 are also provided with a plurality of fixed vanes 100 that may be arranged in three sets of two as shown in Figure 15, but other arrangements are contemplated as well. These vanes serve to reduce the degree of swirl or spin of the gas before it flows gas into the second stage impeller 72 as further described herein.

c2) Second Embodiment – Tapered, Alternating Double Shroud Impeller

[0082] Figures 10-1 to 10-6 illustrate an impeller 62.1 according to an alternative design of the present invention. Like impeller 62 shown in Figs. 8-10, impeller 62.1 includes an alternating shroud design, but in addition it is tapered in elevation view, e.g., the height of each vane varies or tapers along its radial length as shown, for example, in Figs. 10-1 and 10-6. Each vane may also be tapered in widthwise direction, as seen in plan view. This tapered alternating shroud impeller combines the advantages of an alternating shroud impeller (lower costs, lower inertia and better balance) with the advantages of a tapered impeller (more uniform radial air velocity through the impeller and hence lower noise and higher efficiency). As a side benefit, the tapered alternating shroud design also provides excellent stiffness and resistance to bending, drooping, or “creep”.

[0083] As noted above, impeller 62.1 has a tapered design and includes a plurality of continuously curved or straight vanes or blades 88.1 sandwiched between a pair of disk-like shrouds 90.1, 92.1. Each vane 88.1 includes a first edge 88.2 and a second edge 88.3. The radially outer portion 88.4 (Fig. 10-4) of each edge 88.2 abuts or is in contact with or adjacent to an inside surface of shroud 90.1, while the radially inner portion 88.5 (Fig. 10-5) of the edge 88.2 of each vane extends further radially inwardly

beyond shroud 90.1 and is visible through opening 90.2 (also referred to as the “small diameter” of shroud 92.1). Conversely, the radially inner portion of each edge 88.3 abuts or is in contact with or adjacent to an inside surface of shroud 92.1, while the radially outer portion of each edge 88.3 of each vane extends further radially outwards beyond shroud 92.1. and is visible in Figure 10-1. The tapered design is created in this example by forming shroud 90.1 in a truncated frusto-conical shape, while shroud 92.1 is generally planar (see Fig. 10-6). The vanes 88.1 between the shrouds are shaped to fit in the space between the shrouds, such that the vanes gradually taper from the radially inner portion to the radially outer portion of the impeller along the larger-diameter shroud.

[0084] The small and large diameters 90.2, 90.3, respectively, of the truncated cone form a slanted wall 90.4 that is angled relative to shroud 92.1. The angle α is in the range of 0-60°, preferably between 10-30°, depending on the application. By contrast, the shrouds in Figs. 8-10 extend in generally parallel planes, although they may be of varying thickness. The smaller shroud 92.1 incorporates the hub or bushing 50.1 that receives the upper end of the motor shaft 48. The shroud 92.1 overlaps an inner portion of the vanes 88.1, i.e., the outer diameter (OD) of the smaller shroud 92.1 is substantially smaller than the OD of the larger shroud 90.1. Shroud 90.1 is formed with opening 90.2 that does not cover the radially inner portions of the vanes, but shroud 90.1 extends to the radially outer tips of the vanes. Making the OD of the smaller shroud 92.1 slightly smaller than the diameter of the center opening 90.2 in shroud 90.1, facilitates the molding process used to manufacture the impellers.

[0085] By utilizing the differentially sized shrouds (specifically by having only one shroud in the outer portion of the impeller), the inertia of the impellers 62.1 is reduced while the overall rigidity of the impellers is maintained. In this regard, impeller 62.1 is preferably constructed of a polycarbonate or polypropylene material which provides acoustic dampening properties (the latter of which dampens the resonance of the impellers). Glass fiber reinforcement may be employed to increase the stiffness of the polypropylene or polycarbonate if required.

[0086] The radially outer portions 96.1 of the vanes or blades 88.1 may taper in width and the transverse tip edges 98.1 may be stepped, similar to what is shown in Figure 10-6 and/or notched or chamfered 99 as shown in figures 10-7 to 10-10 and described above.

[0087] These vane features are intended to reduce noise, and stepped edges specifically function to break up pressure pulses around the tips of the vanes. In alternative embodiment the trailing edges of the impeller blades may be disrupted by other disturbances, such as but not limited to dimpling or roughening. Such disturbances break up the smooth flow of air trailing off the blade edges and assist in reducing noise.

[0088] Impeller 62.1 is also strong (higher rpms possible) and is even lower inertia (faster response) and possibly quieter than impeller 62, which is a generally parallel arrangement. Further, impeller 62.1 can be made in one piece due to its design.

[0089] The tapered alternating shroud embodiment is low cost and has good balance, very low inertia, low noise, and high strength. The use of a tapered, shrouded design also involves less material usage. The tapered design can also result in more even gas velocity, e.g., velocity is kept constant between the radially inner and outer ends of the vanes.

[0090] The gap between the top of the impeller and the top cover of a double shrouded impeller is not as sensitive to tolerances, compared to a single shroud impeller. On single shrouded (or open) impellers, the top gap is very sensitive to variation, as the air can spill over the top of the blade if the top cover is relatively far away.

d) Volute

[0091] Returning to Figures 7 and 11-13, it will be seen that the first volute is defined by the space 60 (enclosing the first stage impeller 62 and also including an annular volute region immediately outward of the impeller) which is formed by the underside of the top cover 114 and the upper (or outer) side of the motor cap 46. After leaving the first volute 60 (a high velocity region), the air follows an inter-stage (i.e., a stage-to-stage) path 102 which is a radially outer, downward spiral path in the area

between the outer peripheral skirt 64 of the blower motor body 112 and the inner wall 36 of the chassis 24 leading to an inlet opening 104 in the blower motor body bottom cover 116. This inlet opening feeds the air pressurized by the first impeller 62 within the first volute 60 and transferred to the second stage impeller 72 and the second volute 70 via the inter-stage (stage-to-stage) path 102, with the gas flow into the opening 104 smoothed (deswirled) by vanes 100.

[0092] The second volute, as noted above, is defined by the chamber or space 70 enclosing the second stage impeller 72 and continuing in an upward spiral path between the outer and inner walls 64, 44, respectively, of the motor housing, leading to the gas outlet 20, 120.

[0093] It will be appreciated that having the inter-stage (stage-to-stage) path 102 nested concentrically outside the first volute 60 and the second volute 70 provides considerable savings in the overall size of the blower motor assembly, thus enabling it to be installed in a smaller chassis.

[0094] The first and second volutes may have similar or different shapes. However, the first volute can be said to “ramp down”, while the second volute can be said to “ramp up”. Each ramp profile is preferably smooth, but each can also have a stepped gradient as well.

e) Operation

[0095] In operation, and using the embodiment of Figures 4-15 as an example, gas, typically air or oxygen, is supplied to the blower motor assembly 110 via conduit 32 and hole 33. The air is then drawn in through inlet opening 118 and into the first stage impeller 62. The impeller spins the gas and, in combination with the first volute 60 pressurizes the gas. After decelerating as it leaves the first volute, it flows in a downward spiral on the inter-stage (stage-to-stage) path 102, moving into the space between the motor body 112 and the chassis wall 36. Note that the seal at 78 between the motor body top cover 114 and the chassis wall 36 prevents pressurized gas from escaping back into the nonpressurized area above the inlet opening 118. The flexible nature of the seal also contributes to the vibration isolation of the blower motor assembly relative to the chassis enclosure.

[0096] The gas, guided by fixed vanes 100, now flows into the second impeller 72 which, in combination with the second volute 70, further pressurizes the gas until it reaches the motor body assembly outlet 120 and exits via the chassis outlet tube 34.

[0097] While the blower described herein can be used for use in CPAP, NIPPV and BiLevel treatment of OSA, it should be noted that the blower could also easily be used or adapted for use with invasive ventilation as well.

f) Alternative Flexible Sleeve Embodiment

[0098] In an alternative arrangement, a blower motor assembly 200 (Figures 20, 21), similar to the assemblies described hereinabove, is substantially enclosed by a cup-shaped, flexible sleeve 202, best seen in Figures 16-19. The sleeve 202 includes a peripheral side wall 204 and a bottom wall 206. The bottom wall 206 of the sleeve may be formed with internal curved vanes 208 that surround the second stage inlet opening of the blower motor assembly in a manner similar to the arrangement of vanes 100 described above. The vanes 208 are preferably formed integrally with the bottom wall 206, but could be separately applied, if desired, by for example, a suitable adhesive. The vanes could also be formed on the underside of the blower motor assembly bottom cover as in the previously described embodiments. A plurality of support feet 210 are shown

integrally molded within circular recesses 212 formed in the bottom wall 232. Another support arrangement could be one large cylindrical web 211 on the bottom outer face 233 of the sleeve, as shown in Figure 22.

[0099] The peripheral side wall 204 of the sleeve 202 is substantially circular in cross-section, but with a pair of “flats” 214, 216 on either side of an aperture 218 adapted to receive the gas outlet connector boss 220 (see Figure 20). The upper end of the sleeve may be formed with a reduced diameter portion defining an upper rim 222 connected to the adjacent remaining sleeve portion by a radial shoulder 224. Note that the rim 222 merges with the main portion of the sidewall 204 at the flats 214, 216 such that the shoulder 224 terminates at locations 226, 228. Rim 222 terminates at an internal, circular flange or lip 230 located radially inwardly of the rim 222. It will be appreciated that other equivalent attaching and/or sealing arrangements at the open end of the sleeve are within the scope of this invention.

[00100] When applied over the motor body as shown in Figures 20 and 21, the rim 222 of the sleeve engages the peripheral rim of the top cover 232 in a snug, elastic fashion, with lip 230 seated in a circular groove 234 in the cover. This elastic engagement provides a sufficient seal to prevent escape of air/gas from the space between the motor body and the sleeve.

[00101] Figure 21 illustrates the blower motor assembly located within a chassis enclosure 238. It will be appreciated that when pressurized gas/air flows between the stage 1 and stage 2 volutes radially between the blower motor assembly 200 and the flexible sleeve 202), the flexible sleeve may be expanded radially outwardly into at least partial engagement with an interior wall 240 of the chassis enclosure 238. In this condition, vibrations will still be isolated by the air cushion inside the sleeve. In other words, the pressurized inter-stage gas/air thereby at least partially supports the blower motor assembly in a manner that isolates vibration while it also cushions the motor from damage during rough handling, transport, etc. In this regard, the resilient and flexible support feet 210 replace the springs 28, thus eliminating discrete components that can be difficult to handle and assemble.

[00102] A hole 236 in the shoulder 224 (Figure 17) is utilized for wires connected to the blower motor within the motor body. Alternatively, a notch could be provided in the upper lip or rim 222, opposite the aperture 218.

[00103] The flexible sleeve 202 may be made of any suitable flexible material, such as rubber, silicone, silicone rubber or a thermoplastic elastomer (TPE).

[00104] Incorporation of a flexible sleeve permits the size of the blower motor assembly to be reduced since the interstage air/gas now performs two functions in one space, i.e., the flowpath between stages and a vibration isolating and bump cushioning element. In addition, the device may be made quieter since more space is made available to the inlet muffler volume. A further advantage is the elimination of the flexible seal portion 76 of the top cover as described hereinabove.

g) Alternative Blower Motor Assembly Embodiment

[00105] Figure 23 is an exploded view of another alternative embodiment of a blower motor assembly 242 including a first stage impeller 244 associated with a first volute component (also referred to herein as a motor cap or end bell) 246 and a second stage impeller 248 associated with a second volute component (also referred to as the motor body) 250. The blower motor assembly is axially stackable so capable of automatic assembly. Additionally, the volute components are axially compact, and sandwiched between upper and lower lids as described below.

[00106] The first and second volute components 246, 250 are coupled together with the motor M therebetween. For example, the first volute component 246 may include a plurality of holes 252 to receive threaded screws 254 for fastening the first volute component to the second volute component provided with aligned threaded holes for receiving the screws 254. Alternatively, or in addition, the second volute component 250 can be adhesively coupled to the first volute component 246, or the first volute component can be press fit onto the second volute component.

[00107] A rotor 256 of the motor is positioned within between volute components 246 and 250, and the rotor includes a first shaft end 258 coupled to the first

impeller 244 and a second axially aligned shaft end 260 coupled to the second stage impeller 258. A top lid or cover 262 includes an inlet 264 and is positioned over the first impeller, and a bottom lid or cover 266 is positioned under and adjacent the second stage impeller 248. The bottom lid includes a plurality of vanes 268 surrounding an inlet 270. Thus, the top lid or cover 262 in cooperation with the first volute component 246 define a chamber or first volute 247 (Fig. 24) in which the first impeller 244 is located, while the lower lid or cover 266 in cooperation with the underside of the second volute component 250 defines, in combination with the lower lid or cover 266 another chamber or second volute 251, directly below a bottom wall 253 of the second volute component 250, in which the second impeller 244 is located. An inter-stage gas path between the first and second volutes is described in greater detail below.

[00108] A flexible motor sleeve 272 (Figures 23, 24, 35 and 36) surrounds substantially the entire assembly, but includes a cut out portion 274 to receive the outlet 276 of the second volute component 250. The sleeve 272 is an elastomeric component that dampens vibration and/or resonance of internal components. The use of the sleeve 272 may result in fewer parts as compared to common motor assemblies. The sleeve 272 may be insert-molded onto aluminium, or it may co-molded onto the top and/or bottom lids.

[00109] Figure 24 shows additional details of the motor M and its positional relationship to the first and second volutes. The motor M includes a laminated stack 278, a plurality of windings 280 and rotor magnet 282. The motor shaft 284 (which includes shaft ends 258, 260) is supported by upper and lower bearings 286, 288. Further, the volute components 246, 250 are at least partially nested, which provides for a compact and space saving design, particularly in the axial direction, while the sleeve 272 also helps conserve space in a radial direction. The sleeve 272 is sealingly coupled to the motor assembly, e.g., using a thickened portion 290 of silicone around its upper surface, as shown in Figures 24 and 33, stretched about the edge of the upper lid or cover 262.

[00110] Figure 25 shows the first volute component 246 with a part annular ramp surface 292 defining a flow channel 294 extending approximately 180° with increasing depth from an "inlet" end of the channel at 296 to an "outlet" end 298. Figures 26-30 illustrate the first and second volute components 246, 250 in combination,

without the motor. These figures illustrate the inter-stage path of a gas (for example, air) as it is channelled from the first impeller 244 to the second impeller 248, and hence from the first volute 247 to the second volute 251. This inter-stage path is generally concentric relative to the motor shaft 284 and defines a transition zone designed to ramp downwardly in a spiral fashion from the first volute to the second volute. More specifically, the first two arrows in Figure 26 lie on surface 292 of channel 294 in the first volute, and the third arrow lies on a more steeply-inclined ramp surface on the outside of the second volute component 250, which, in turn, continues along a substantially horizontal surface 302, also on the second volute component 250.

[00111] This arrangement allows the gas to decelerate as it ramps down and expands. Note that a groove 304 is now formed between surface 302 and the underside of the first volute component 246. This groove is tapered in the circumferential direction, with surface 302 rising slightly toward the first volute component 246 as best seen in Figures 28-30 so as to encourage forward and continued movement gas remaining in the first volute 246 and any decelerated gas in the inter-stage path, about the second volute component 250. A notch 255 in an inner wall 257 of the second volute component 250 permits passage of the motor wires (not shown).

[00112] In use, the gas spirals downwardly through the transitional zone and enters into the area 306 which also extends below the bottom lid or cover 266 and then into the opening 270 and into the second volute 251. Vanes 268 reduce the degree of swirl or spin as the gas flows to the second volute where the gas is then swirled about the volute 251 via second impeller 248 and upwardly to the outlet 276.

[00113] As shown in Figures 23 and 31 the top lid or cover 262 includes a flat upper surface 307 provided with the inlet opening 264 and a peripheral depending skirt 308. An outlet hood 310 depends from a portion of the skirt 308 and covers the transition zone between the first and second volutes, allowing the gas to move radially outwards to fill the stage-to-stage or inter-stage path. Attachment tabs 312, 314 and 316 serve to attach the upper lid to the underside of the first volute component 246.

[00114] With reference to Figures 23, 24, 33 and 34, the bottom lid 266 is also formed with upstanding attachment tabs 314, 316, 318 on skirt 320 adapted to engage a peripheral rim 322 on the second volute component 250. With the first volute component 246 securely fastened to the second volute component 250 via screw fasteners 254, and with the upper and lower lids 262, 266 snap-fit onto, or otherwise attached to the first and second volutes components, respectively, it will be appreciated that assembly of the compact unit is easily achieved. The flexible sleeve 272, best seen in Figures 23 and 24, 35 and 36 is telescopically received over the motor/volute assembly so as to further define the inter-stage gas path, as described above in connection with the embodiment illustrated in Figure 21, and the manner in which the sleeved blower motor assembly described in connection with Figures 23-36 operates is otherwise similar to the embodiment shown in Figures 16-21.

[00115] With regard to the impellers 244 and 248, each of the blades may be tapered towards the outside of the impeller, e.g., to axially move the blade tips from the cut-off to decrease the blade pass tone. This structure may also maintain the cross-sectional area as moving out from the center of the impeller closer to constant. This will encourage the airflow to maintain contact with the blades, to increase efficiency and/or decrease noise. In another variant, the surfaces of the components adjacent the impellers could be tapered to match the impeller shapes, thereby providing a constant distance between those surfaces and the impeller blade edges. The impellers 244, 248 also have an alternating shroud design as described above which can also help reduce noise.

[00116] The motor assembly thus described has a low inertia which may allow for use in other applications, e.g., to respond quickly for other therapies and/or to increase response of transducer(s). Further, the temperature of the motor is cooler, and drag from the bearing heat is less due to running the slower speeds of the motor, which helps with reliability. Also, the integrated volutes can help conduct heat into the air path to warm the air, which also has the effect of improving the reliability of the motor. Further, the generated heat can warm the air path, which can be advantageous in cooler conditions. Another benefit is that there is less pressure across the bearings as a result of multistage air path.

h) Additional Features

[00117] In another variant, a mode of operation may be provided where the flow through the motor is intentionally oscillated to be faster than the breathing rate. The results can be useful for diagnostic purposes, e.g., to determine open or closed airway or for other diagnostic purposes. Suitable oscillation techniques are described in commonly owned U.S. Patent No. 5,704,345. Such information can also be used to activate an active vent.

[00118] A thermal cutout may be provided on the motor. The cutout would monitor the heat in the motor casing, and shut off power in the event of an overheat.

[00119] In another embodiment, the impellers could be structured to spin in either the same directions or in opposite directions.

[00120] In yet another variant, the blower assembly could include a port for water egress, such as holes at the bottom of the sleeve, to protect against water pooling at the bottom of the motor if it spills back from an attached humidifier.

[00121] Further, the motor housing body and the first and second volute components may be integrated.

[00122] While the invention has been described in connection with what are presently considered to be the most practical and preferred embodiments, it is to be understood that the invention is not to be limited to the disclosed embodiments, but on the contrary, is intended to cover various modifications and equivalent arrangements included within the spirit and scope of the invention. For example, while many aspects of the invention relate to double ended or multi-stage blowers (two or more stages), single stage blowers are also contemplated. On the other hand, each end of the motor shaft may include multiple impellers. Also, the various embodiments described above may be implemented in conjunction with other embodiments, e.g., aspects of one embodiment may be combined with aspects of another embodiment to realize yet other embodiments. Further, each component or feature alone for any given embodiment may constitute an independent embodiment. In addition, while the invention has particular application to patients who suffer from OSA, it is to be appreciated that patients who suffer from other illnesses (e.g., congestive heart failure, diabetes, morbid obesity, stroke,

bariatric surgery, etc.) can derive benefit from the above teachings. Moreover, the above teachings have applicability with patients and non-patients alike in non-medical applications.

WHAT IS CLAIMED IS:

1. A double-ended blower comprising:

a blower motor assembly supporting opposed first and second shaft ends, said first and second shaft ends having respective first and second impellers attached thereto and enclosed within first and second volutes, respectively, wherein the first volute is connected to an inlet and the second volute is connected to an outlet; and said blower motor assembly supported in a chassis enclosure; a radially outer inter-stage path between the first and second volute, wherein said second volute is at least partially substantially concentrically nested with the radially outer inter-stage gas path.

2. The double-ended blower of claim 1, wherein said blower motor assembly is supported on a plurality of resilient members and otherwise spaced from said chassis enclosure to thereby substantially vibrationally isolate said blower motor from said chassis enclosure.

3. The double-ended blower of claim 1, wherein said blower motor assembly includes a motor body including a bottom wall, a peripheral sidewall, a motor cap and top and bottom covers, wherein said first impeller is located in a first space between said motor cap and said top cover, and said second impeller is located in a second space between said bottom wall and said bottom cover.

4. The double-ended blower of claim 3, wherein said second volute is located radially inward of said inter-stage path.

5. The double-ended blower of claim 4, wherein said first volute is located radially inward of said inter-stage path.

6. The double-ended blower of claim 5, wherein said second volute is located wholly within said motor body.

7. The double-ended blower of claim 4, wherein an underside of said bottom wall of said blower motor assembly is provided with a plurality of fixed vanes for deswirling air entering the second volute.

8. The double-ended blower of claim 3, wherein said top cover is provided with an inlet opening for supplying un-pressurized gas to said first impeller, said inlet opening in fluid communication with a gas inlet to said chassis enclosure.

9. The double-ended blower of claim 1, wherein said top cover is provided with a flexible seal that engages an inner wall surface of said chassis enclosure.

10. The double-ended blower of any one of claims 1-9, wherein each impeller includes a plurality of vanes that taper in width in a radially outer portion thereof.

11. The double-ended blower of claim 10, wherein each vane has a stepped transverse edge at a radially outer end thereof.

12. A double-ended blower of any one of claims 1-11, wherein each impeller includes a plurality of curved vanes, each vane tapering in width in a radially outer portion thereof.

13. The double-ended blower of claim 12, wherein each vane has a stepped transverse edge at its radially outermost end.

14. The double-ended blower of any one of claims 12-13, wherein each impeller is constructed of polycarbonate material.

15. The double-ended blower of any one of claims 12-13, wherein each impeller is constructed of polypropylene material.

16. The double-ended blower according to any one of claims 12-15, wherein each vane has a stepped transverse edge at its radially outermost end.

17. The double-ended blower according to any one of claims 12-16, wherein each impeller is formed with surface disturbances along trailing edges thereof.

18. The double-ended blower of any one of claims 1-11, wherein each impeller comprises:

a top shroud;

a bottom shroud,

a plurality of vanes extending from the top shroud to the bottom shroud, each said vane including a top edge at a radially inner portion of the vane in contact with the top shroud and a bottom edge at a radially outer portion of the vane in contact with the bottom shroud, such that a radially inner portion of the vane at the bottom edge of each vane is not in contact with or adjacent the bottom shroud and a radially outer portion of the vane at the top edge of each vane is not in contact with or adjacent the top shroud.

19. The double-ended blower of claim 18, wherein each said vane has a width that is approximately constant from the radially inner portion to the radially outer portion.

20. The double-ended blower of claim 18, wherein each said vane has an edge thickness and/or height that varies from the radially inner portion the radially outer portion.

21. The double-ended blower of claim 20, wherein the edge thickness and/or height tapers down from the radially inner portion to the radially outer portion.

22. The double-ended blower of any of claims 18-21, wherein the top shroud is of truncated frusto-conical shape, having a surface that is angled relative to the bottom shroud in the range of about 15-25 degrees.

23. The double-ended blower of claim 18, wherein the inter-stage gas path includes a ramped surface internal to said first volute which merges with a peripheral external surface on said second volute.

24. The double-ended blower of claim 23, wherein said bottom cover is formed with an inlet for supplying gas from said inter-stage gas path to said second volute.

25. The double-ended blower of claim 23, wherein said peripheral external surface on said second volute forms one portion of a peripheral groove that tapers in a circumferential direction.

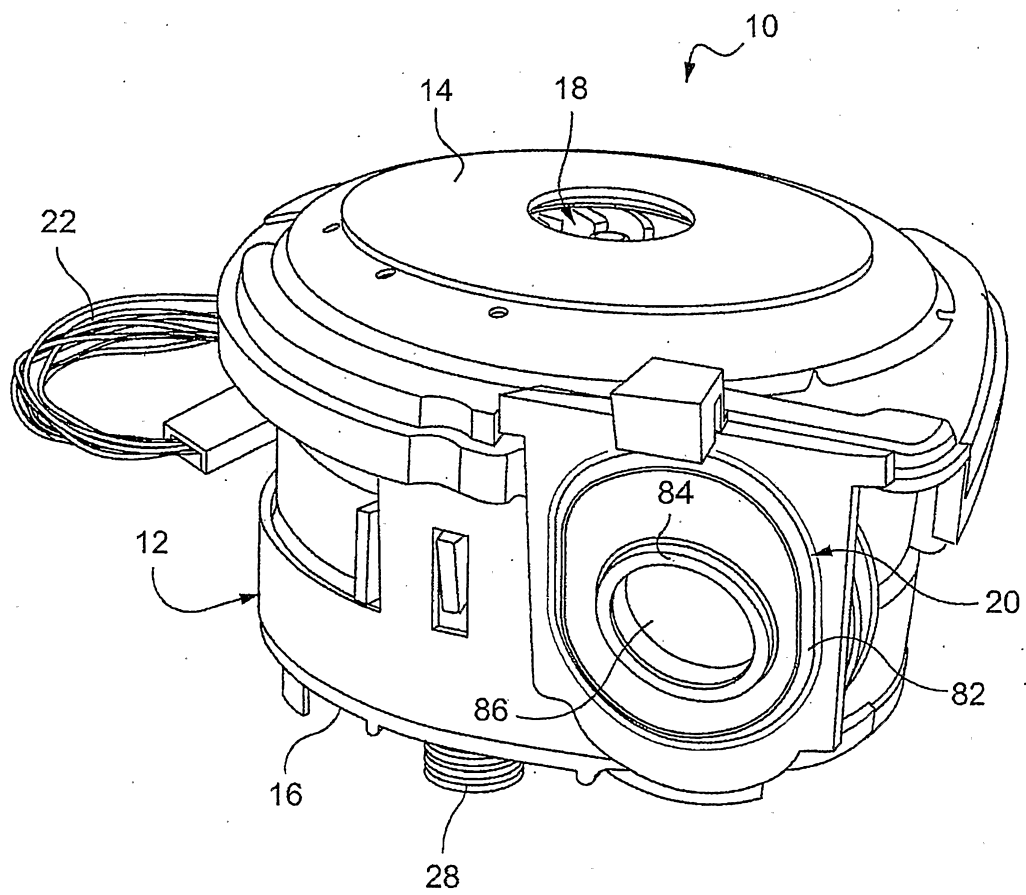

Fig. 1

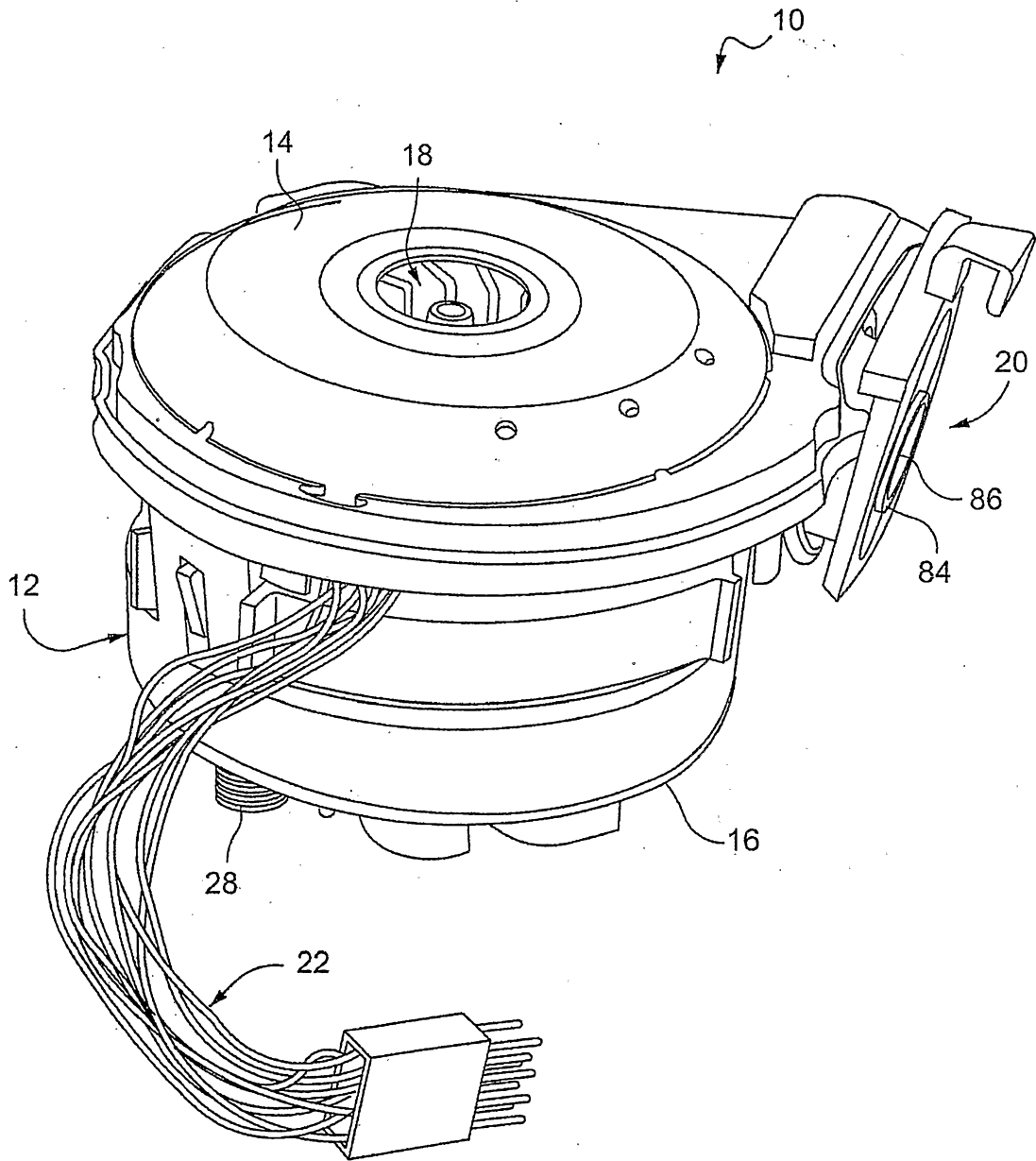

Fig. 2

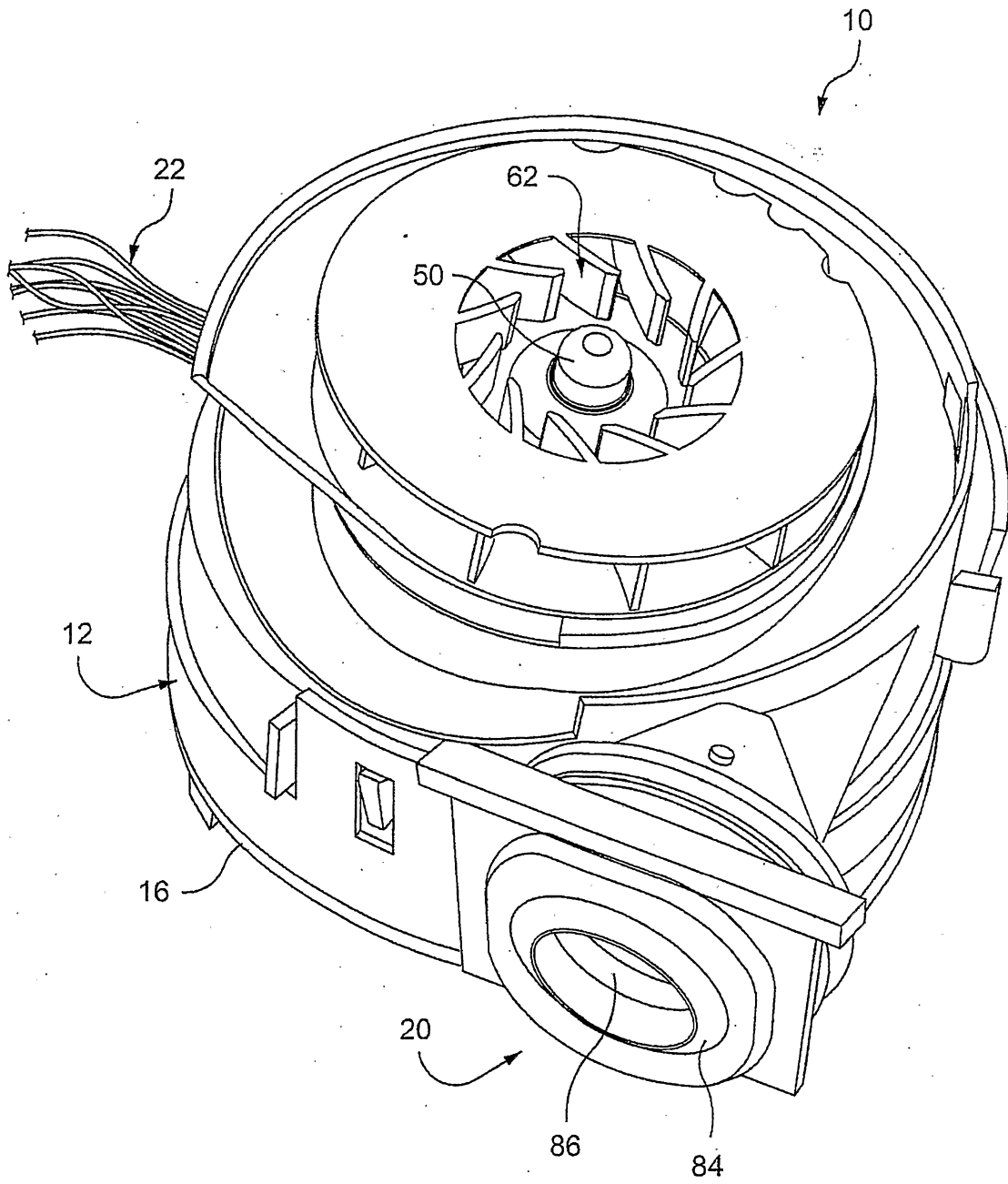

Fig. 3

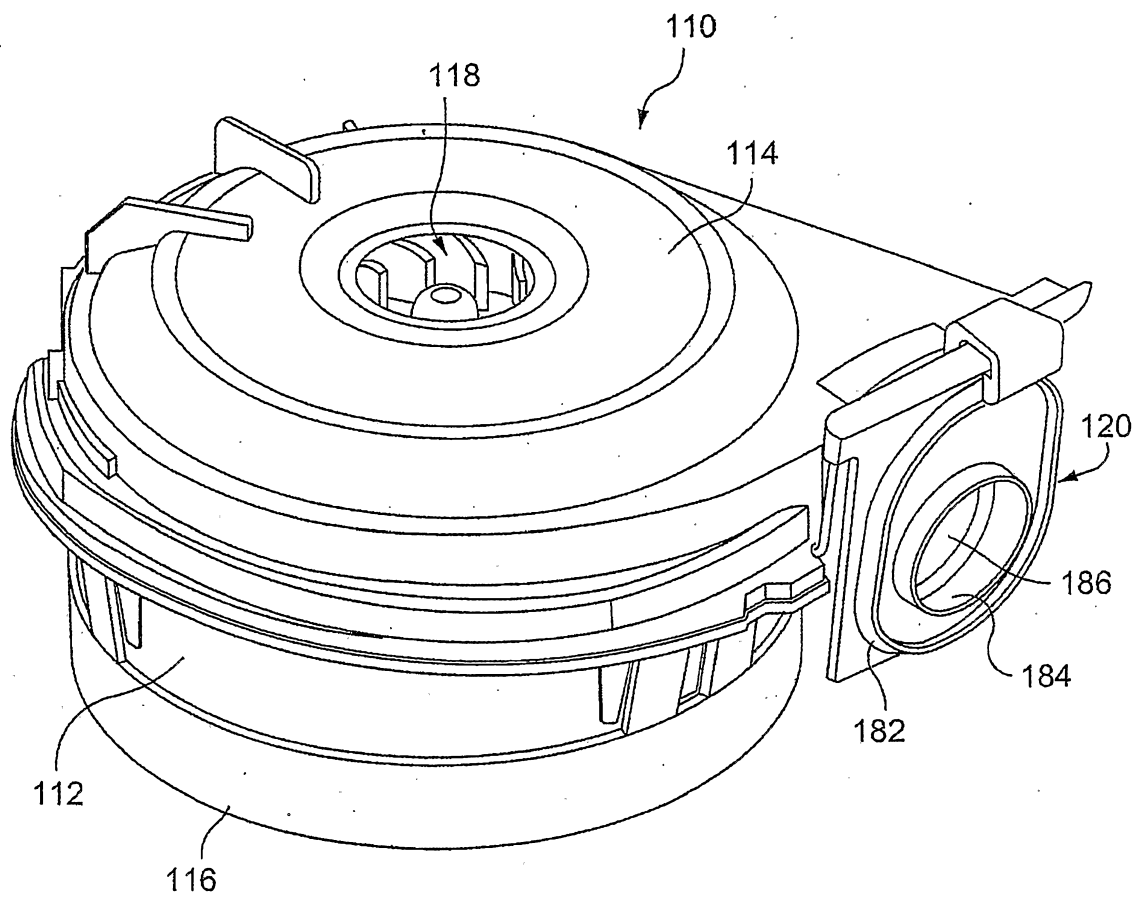

Fig. 4

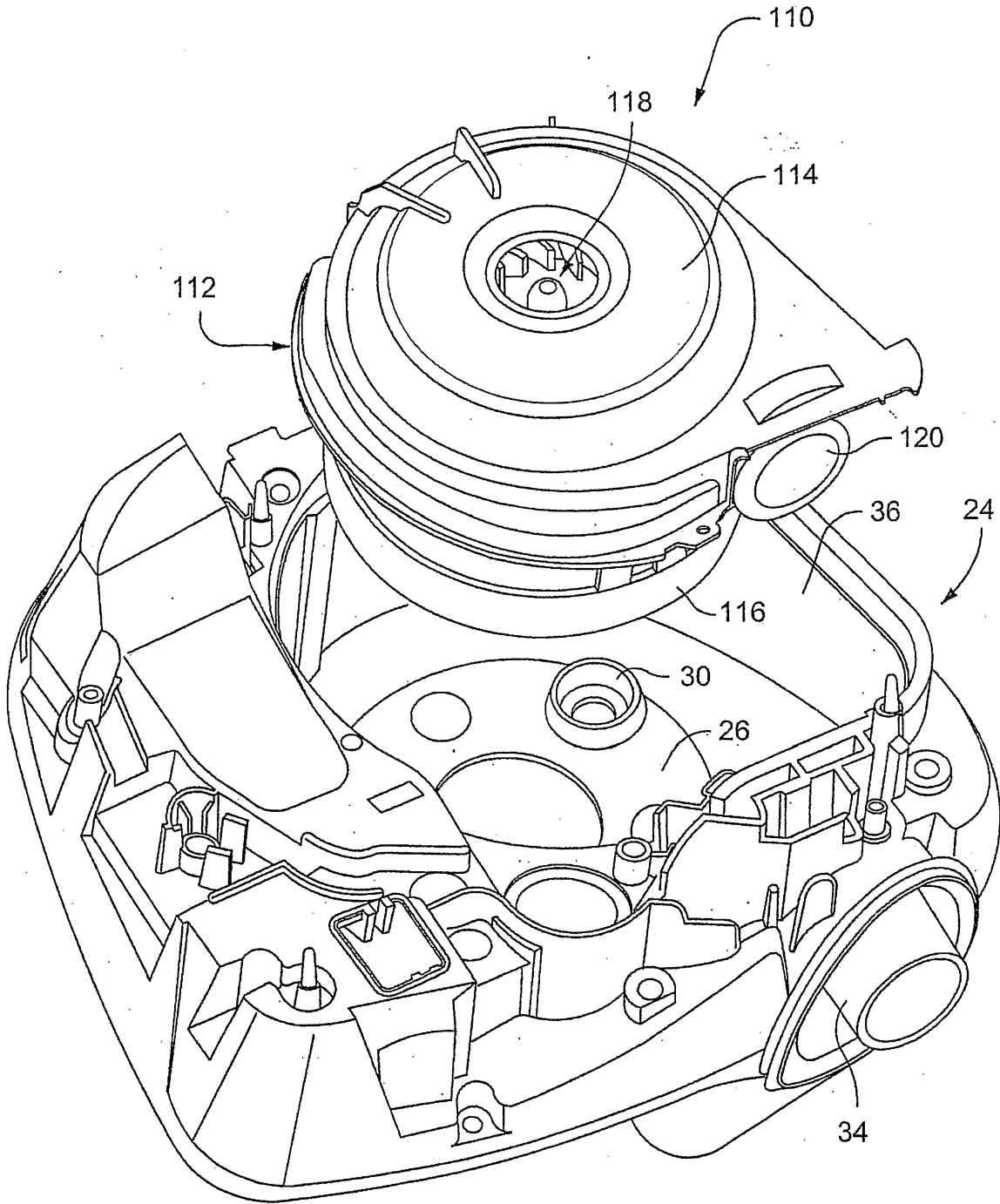

Fig. 5

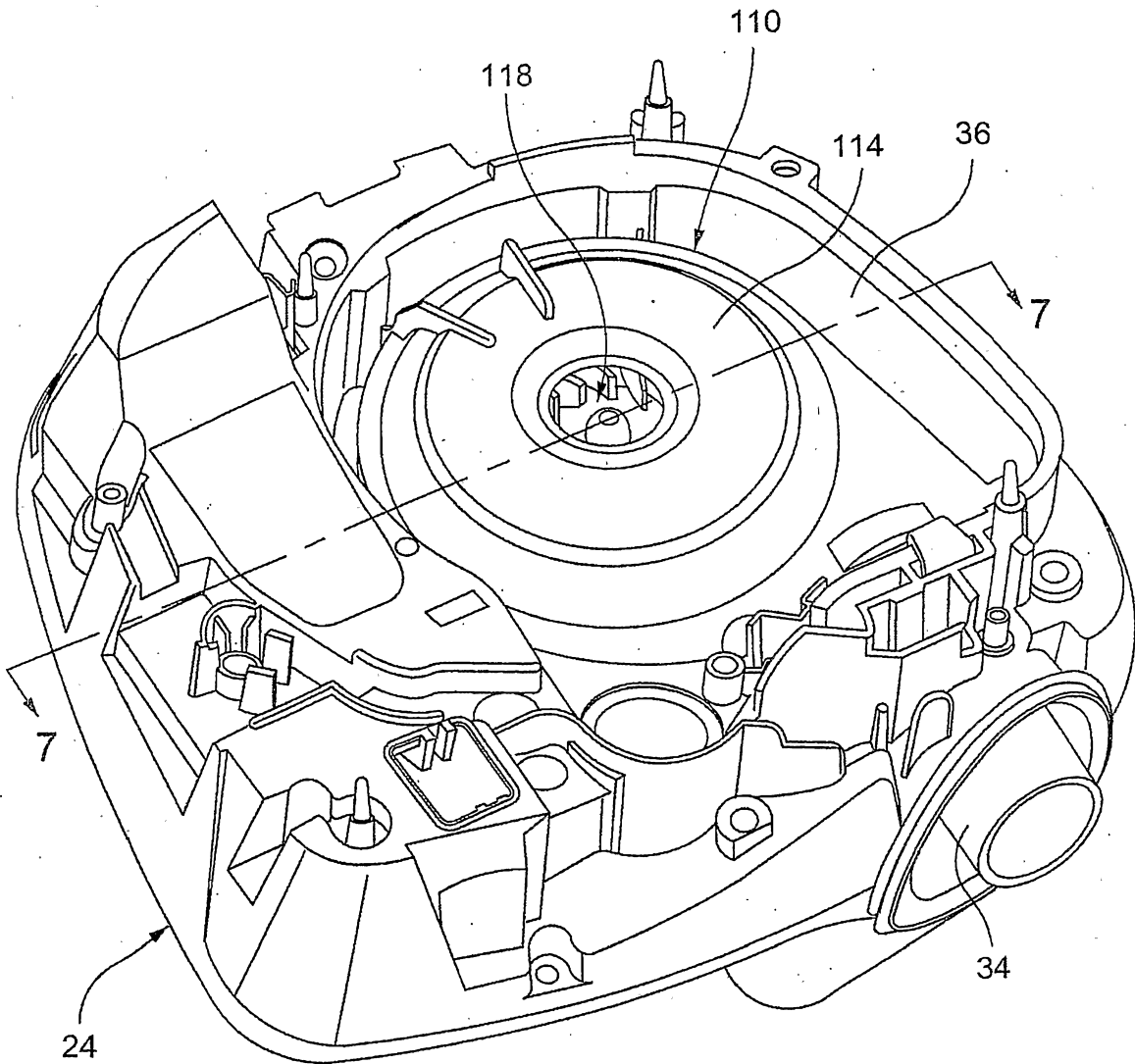
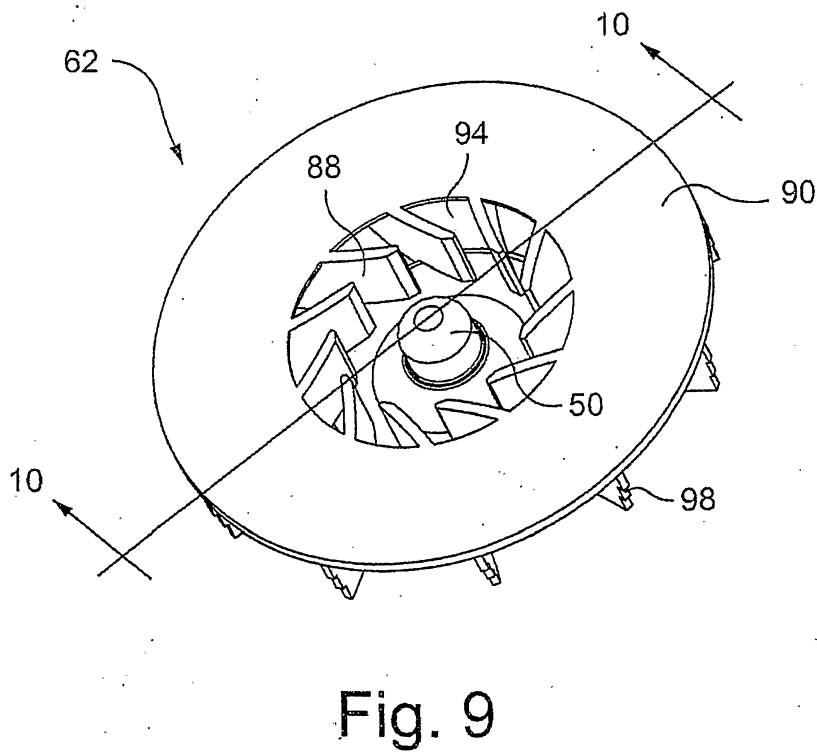
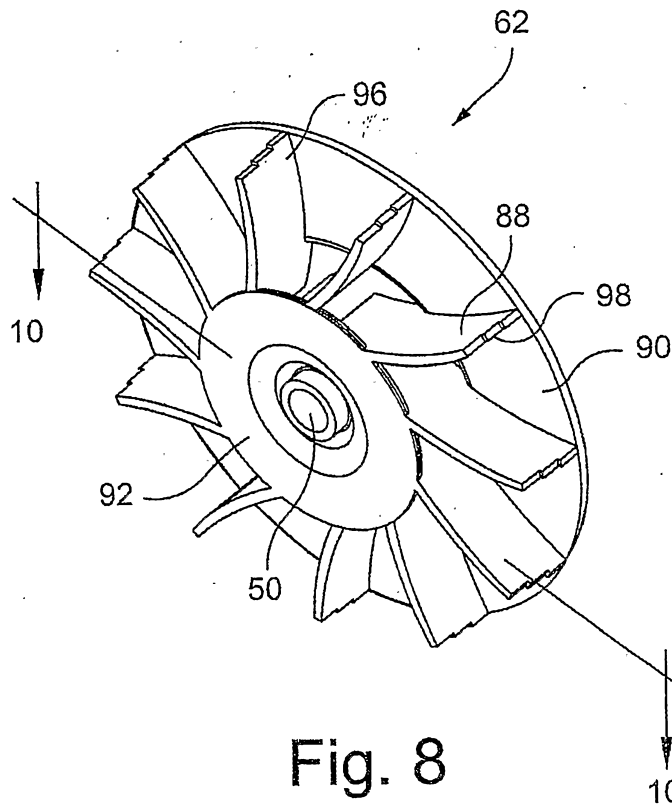

Fig. 6



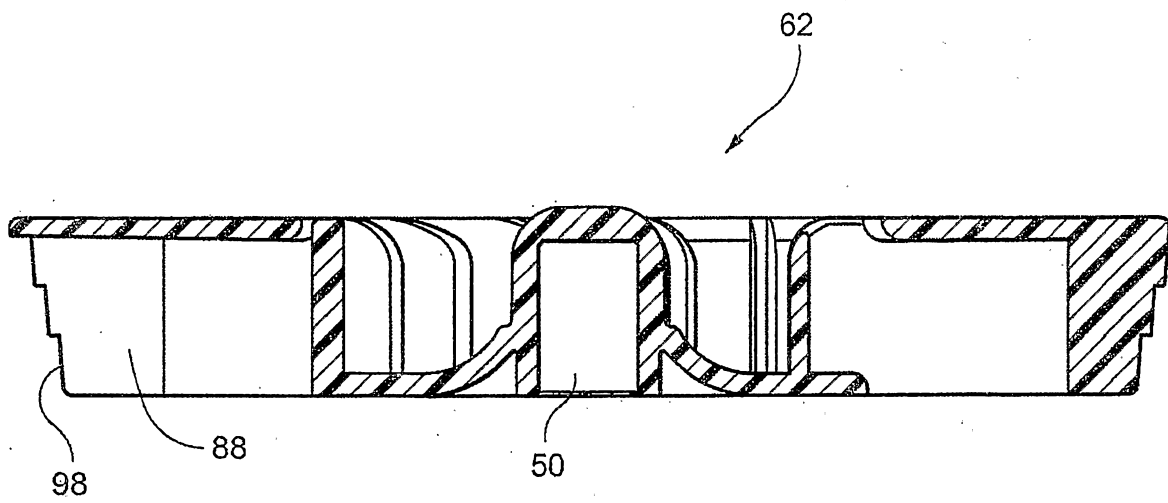

Fig. 10

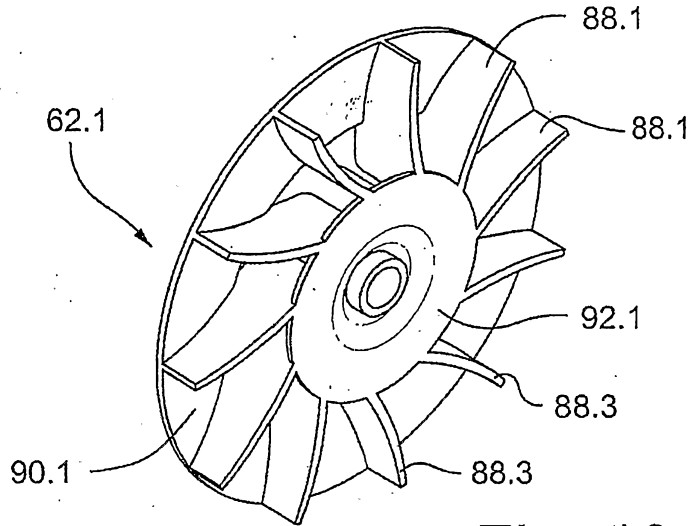

Fig. 10-1

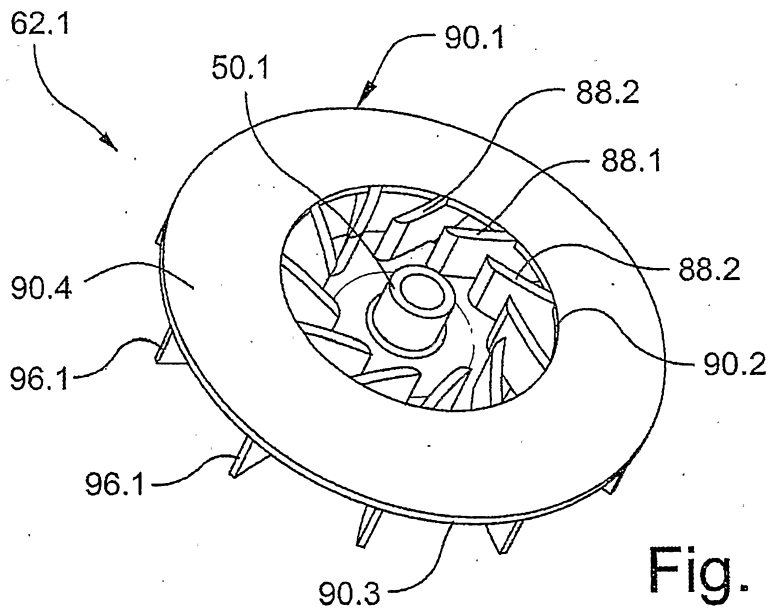

Fig. 10-2

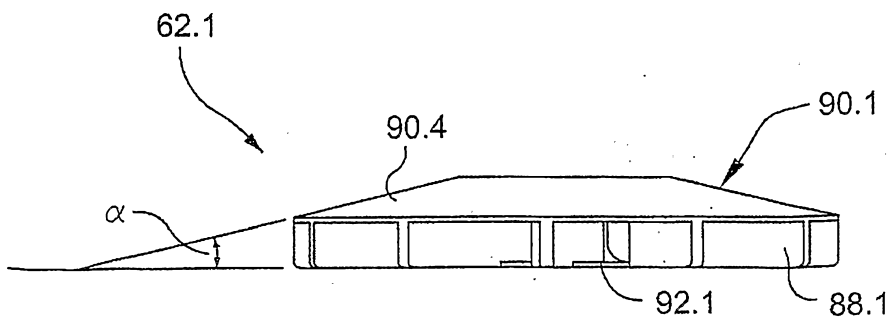

Fig. 10-3

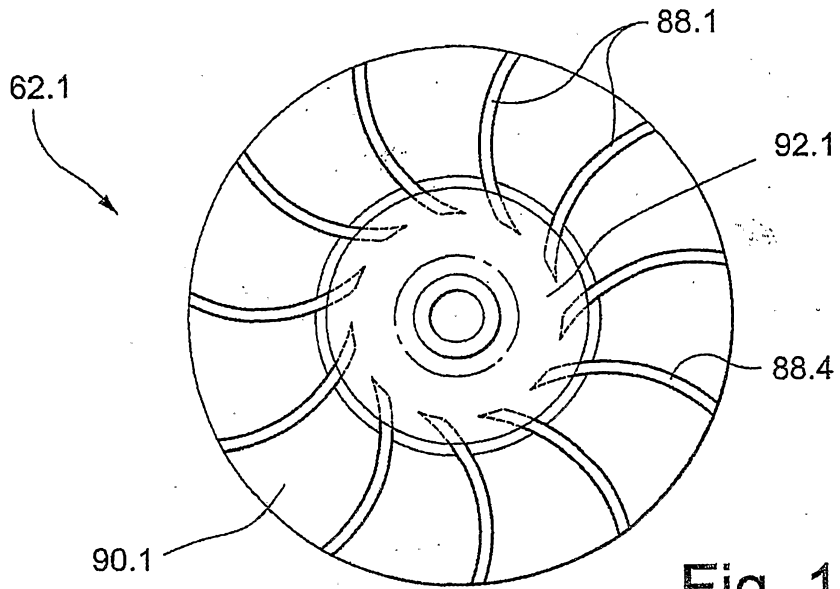

Fig. 10-4

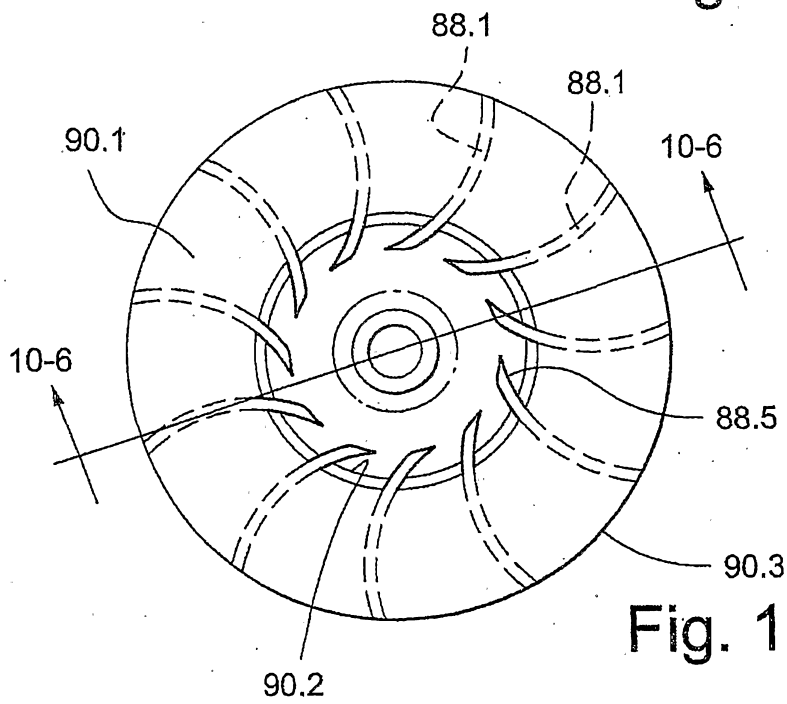

Fig. 10-5

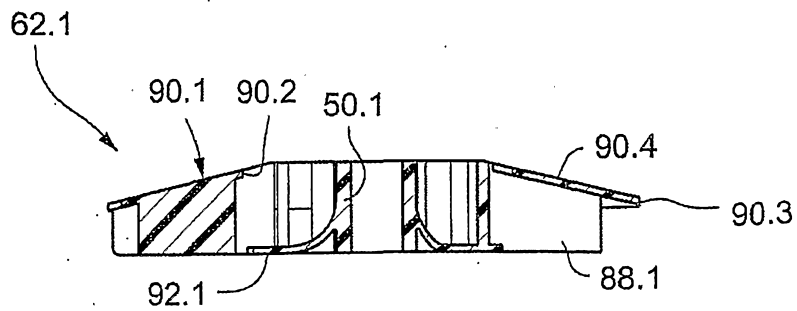
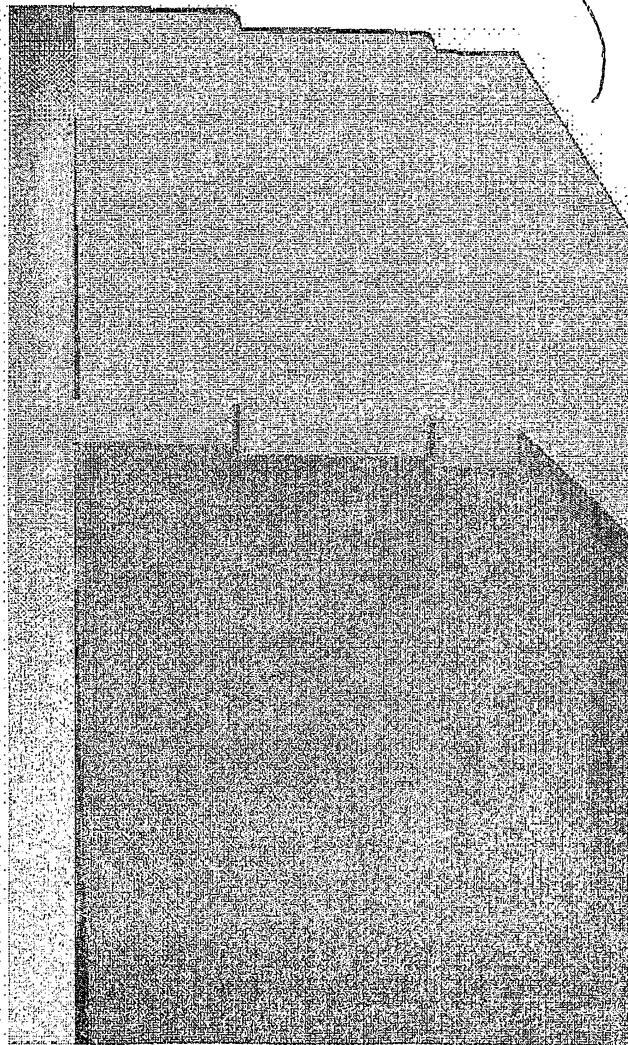

Fig. 10-6



99.1

Fig. 10-7

88.3

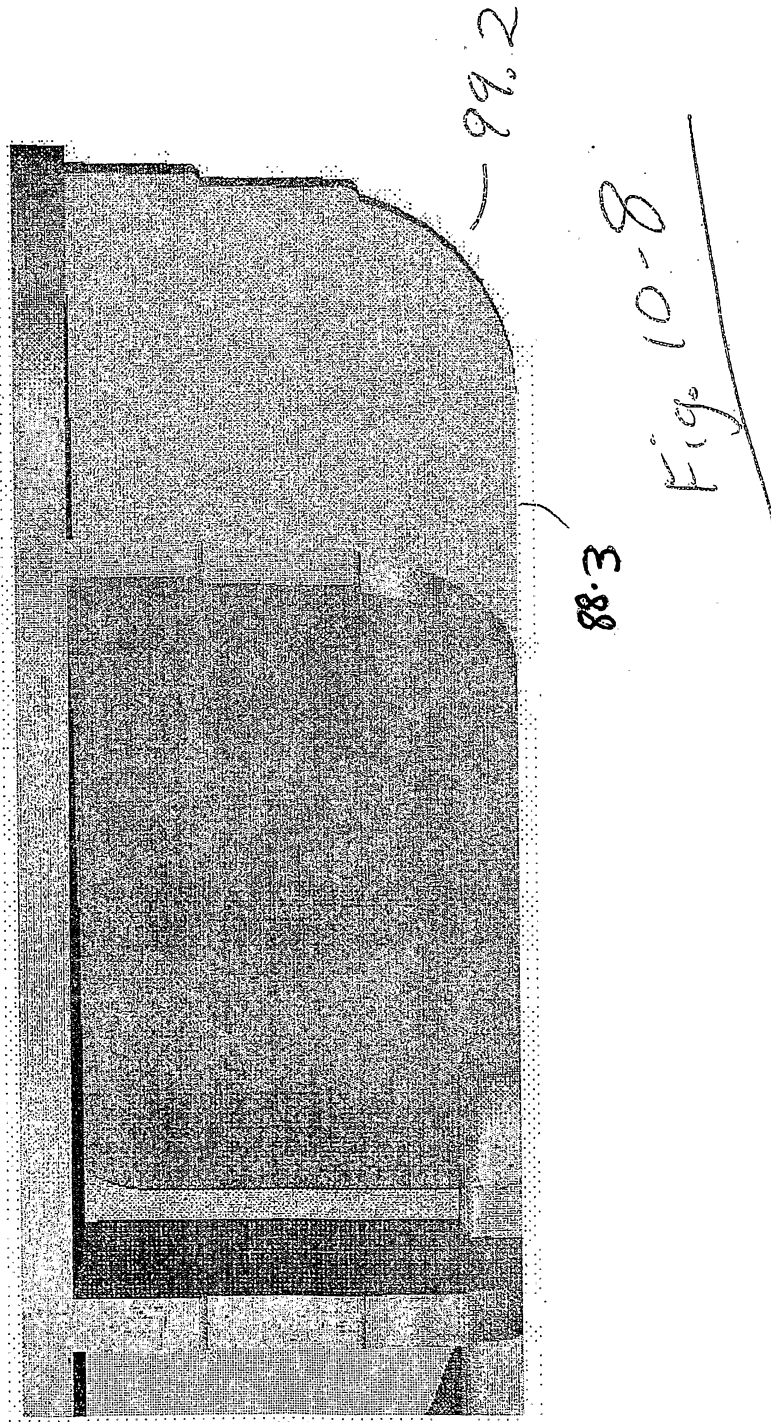

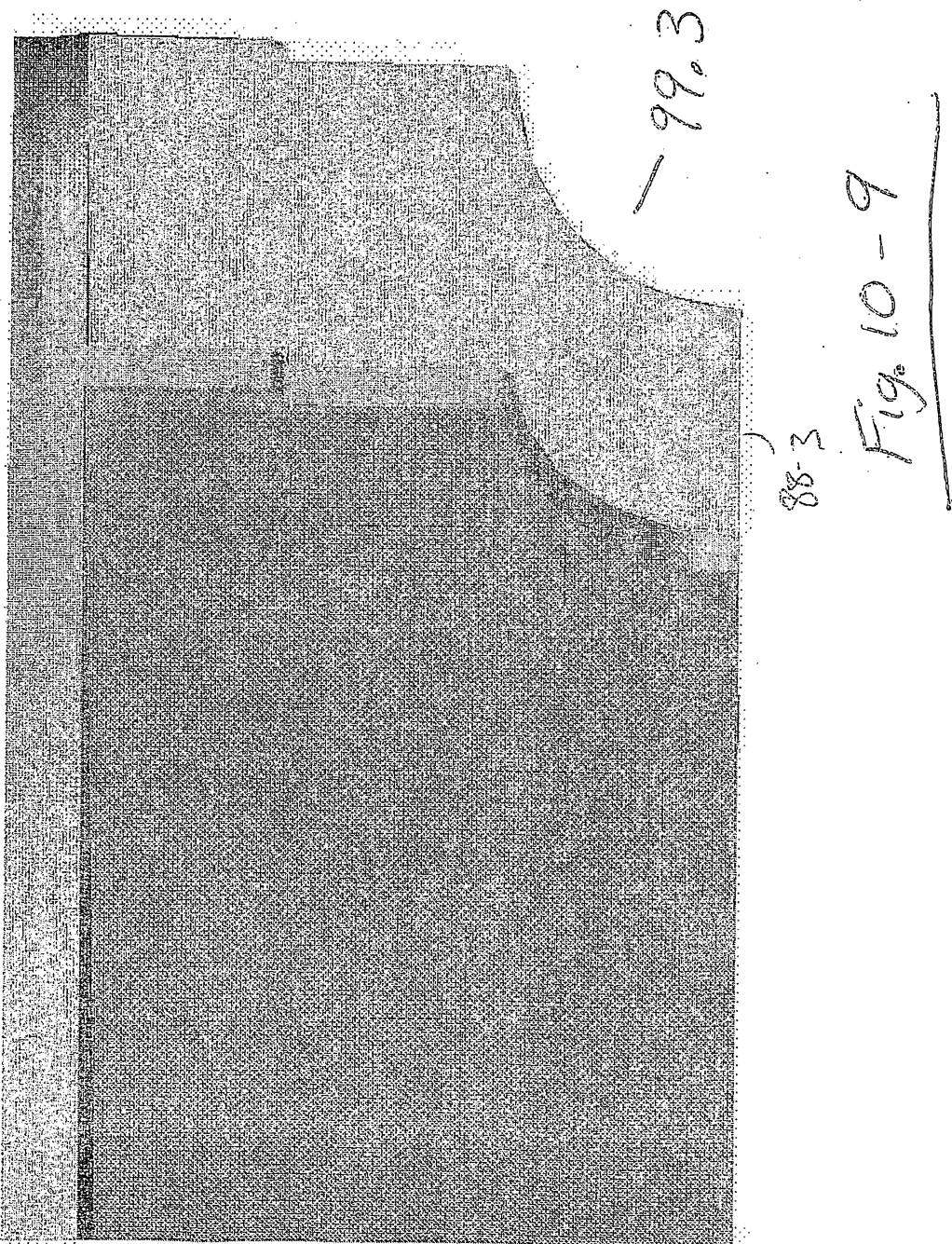

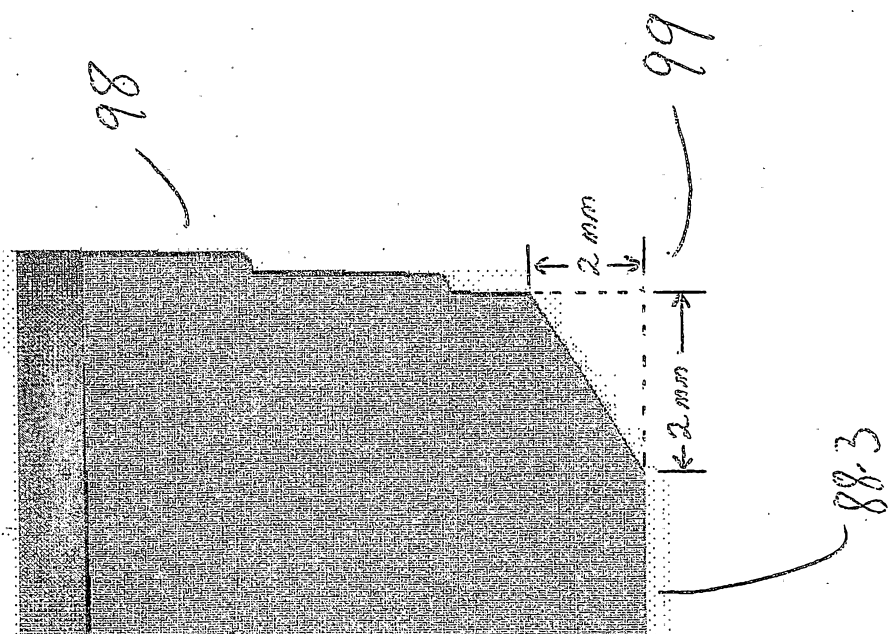

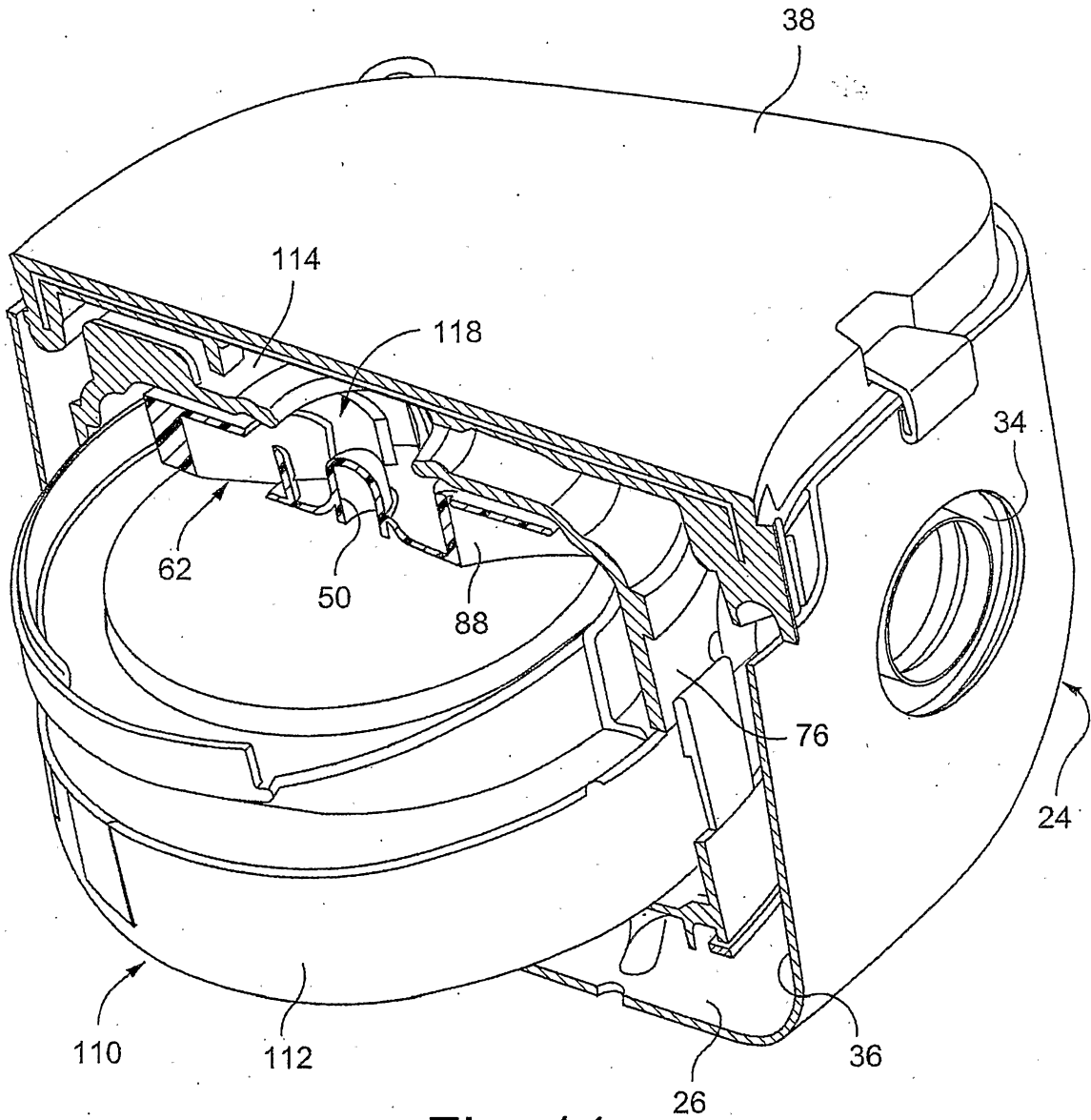

Fig. 11

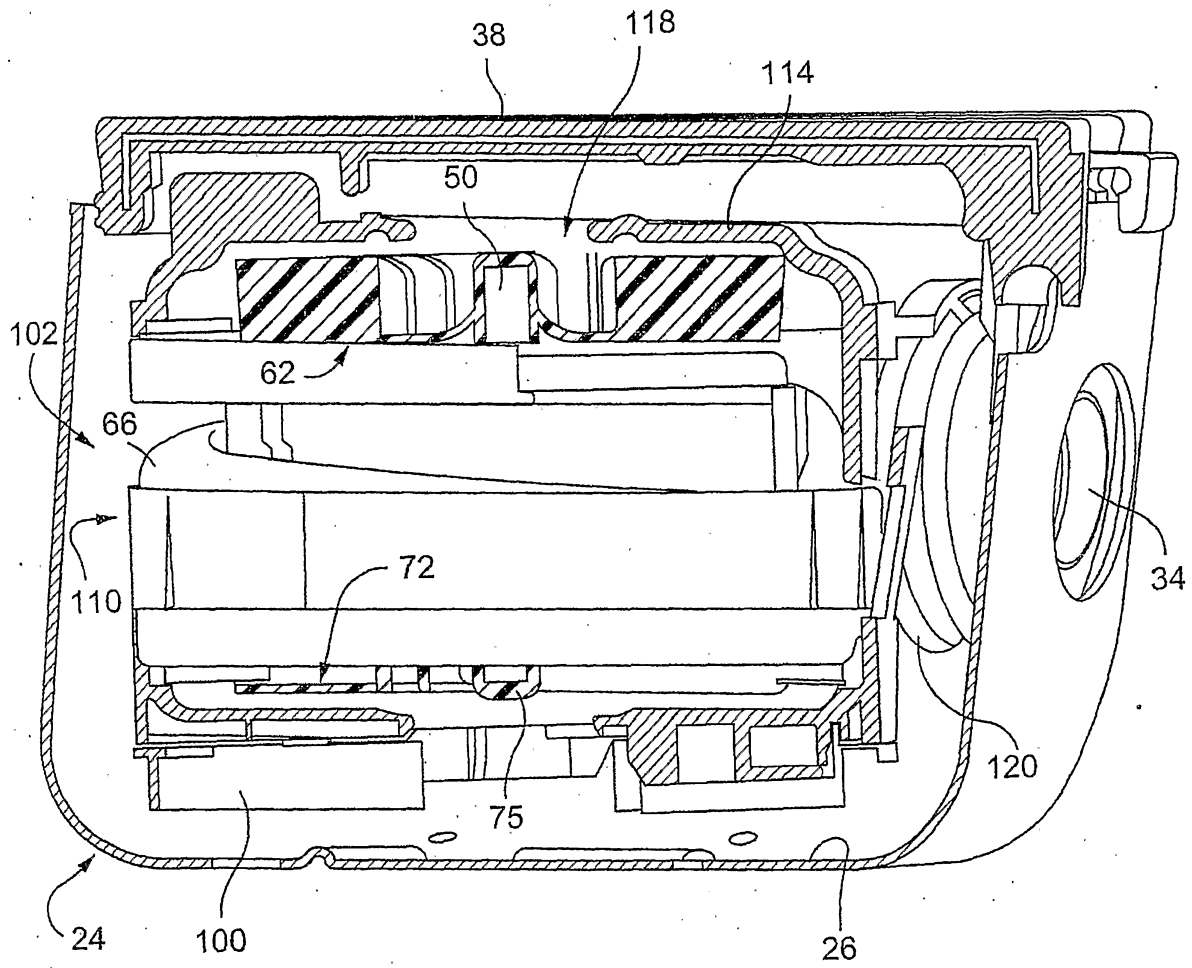

Fig. 12

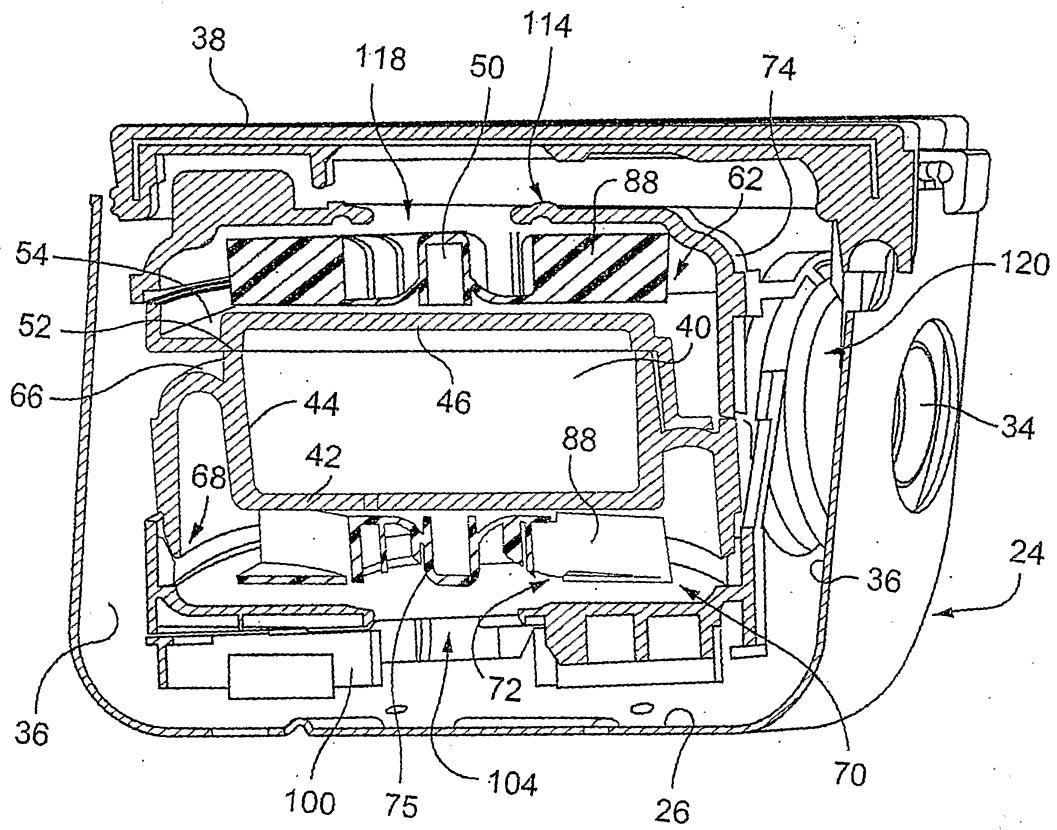

Fig. 13

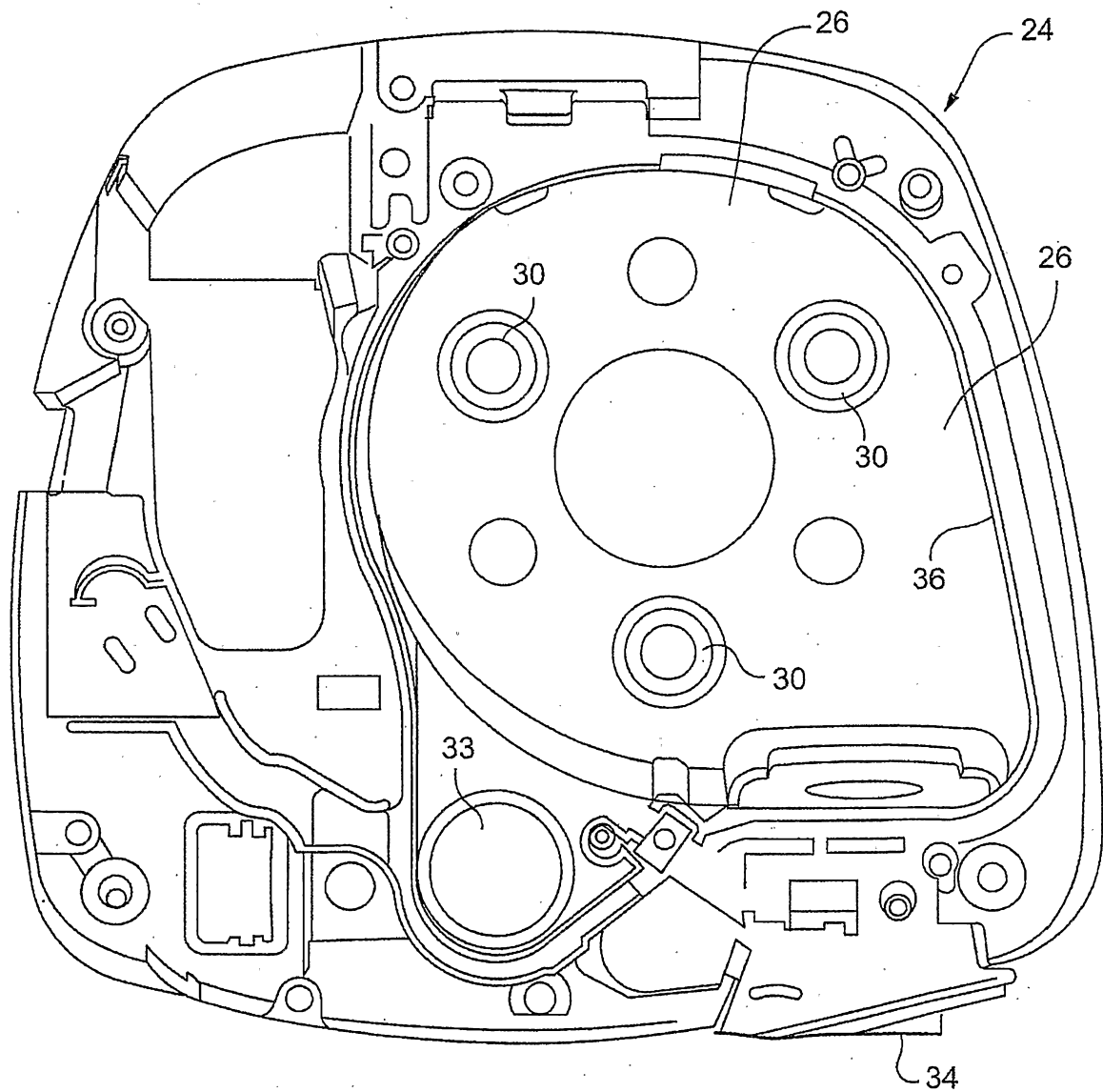

Fig. 14

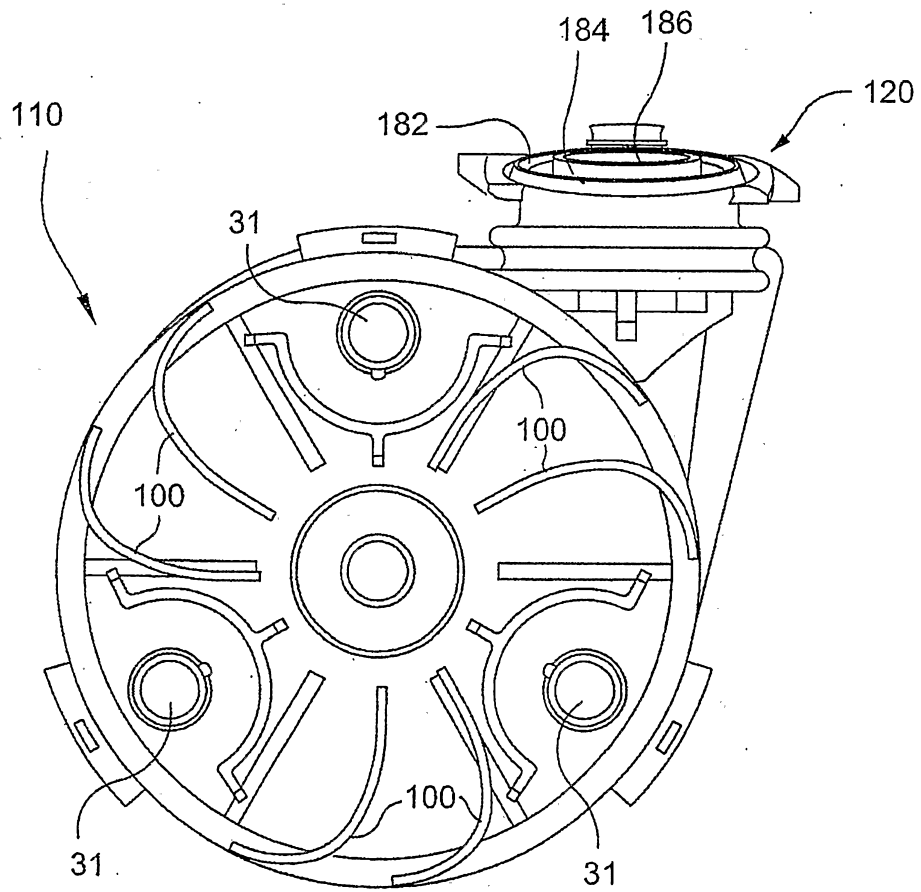

Fig. 15

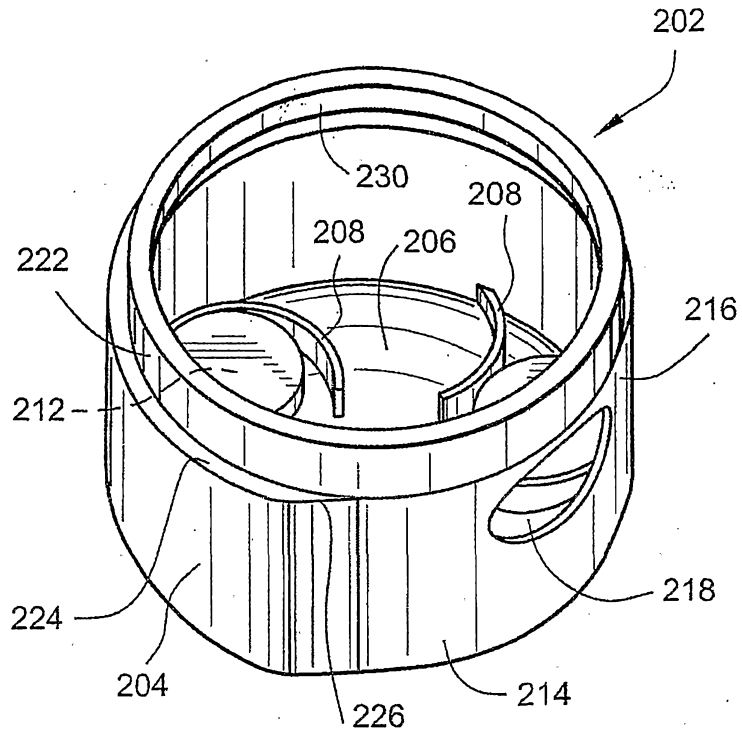

Fig. 16

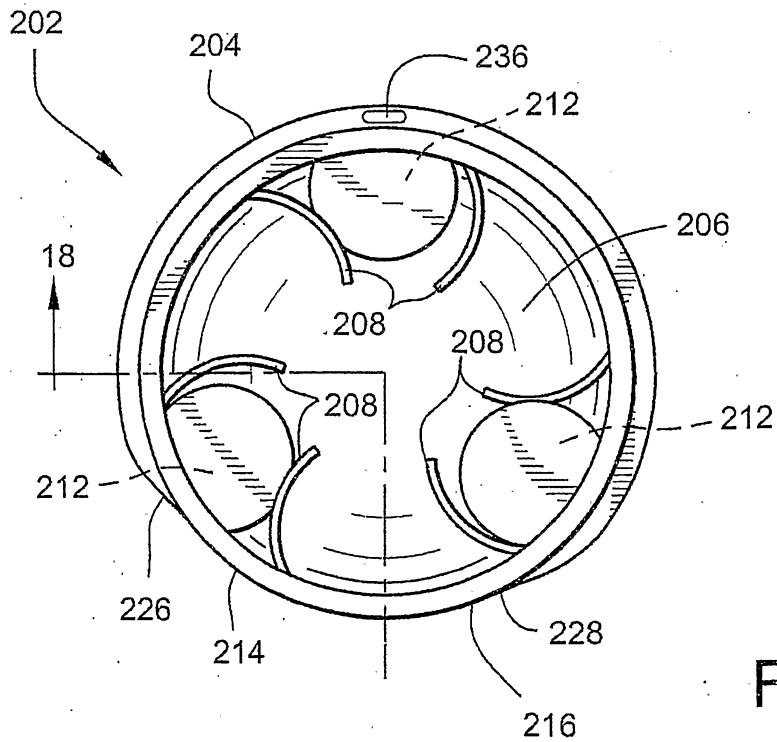

Fig. 17

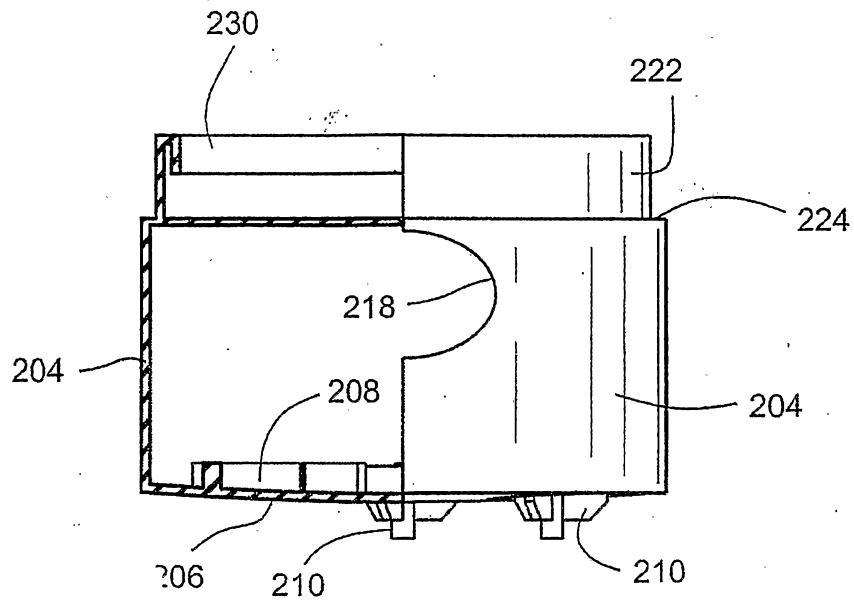

Fig. 18

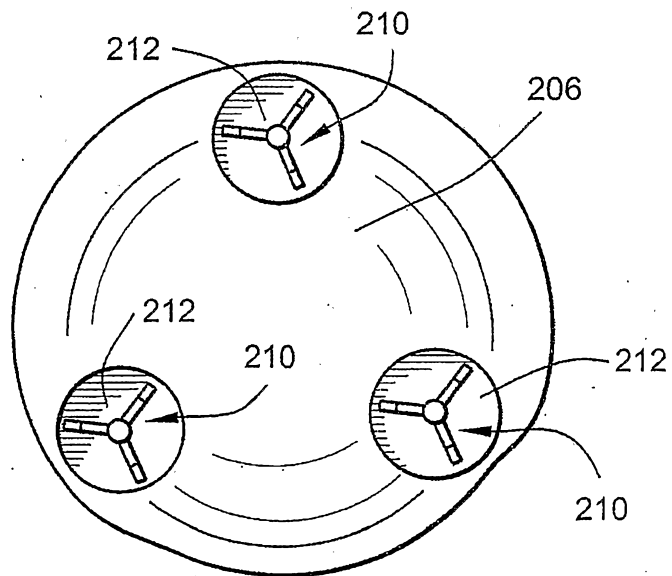

Fig. 19

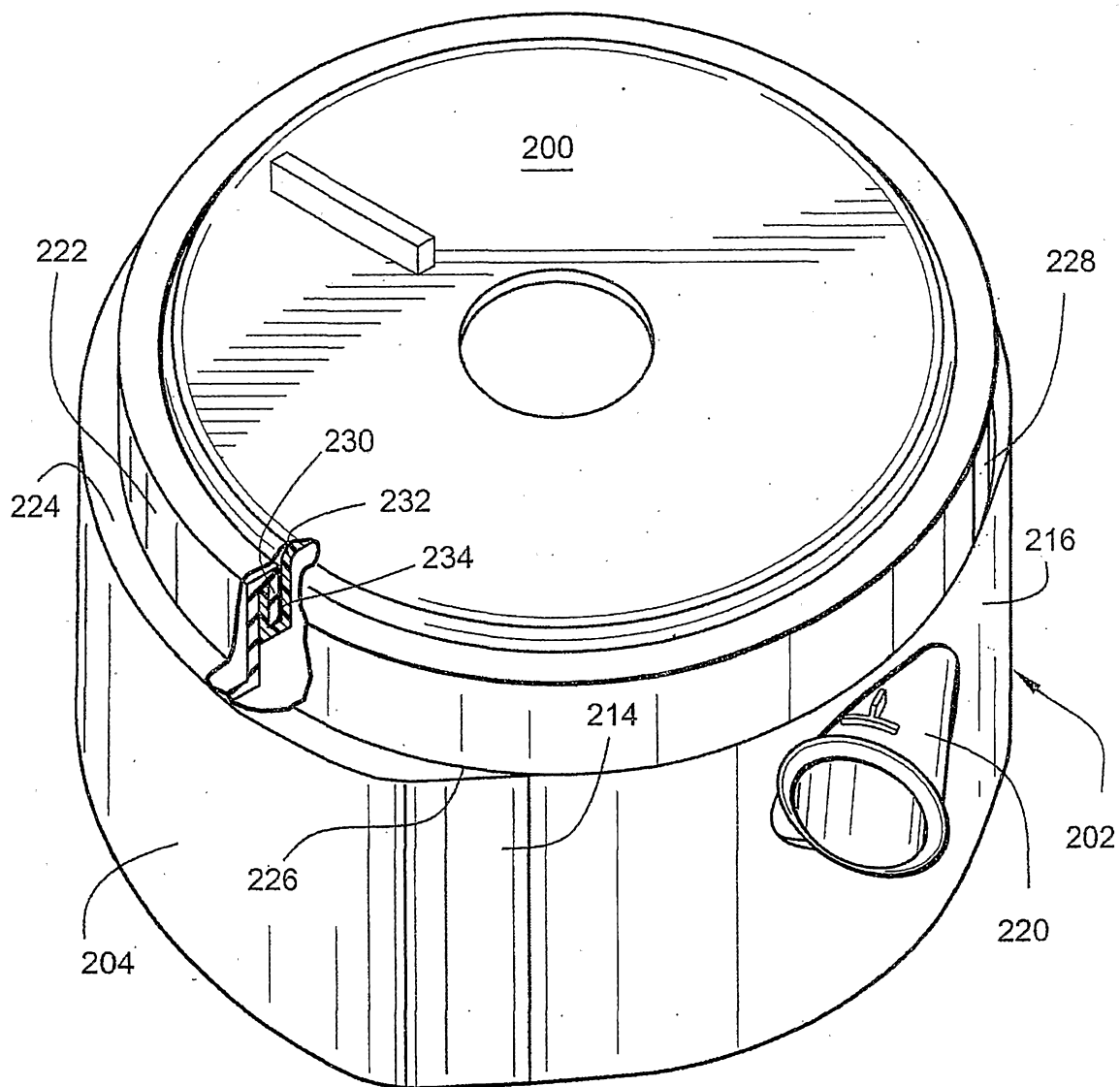

Fig. 20

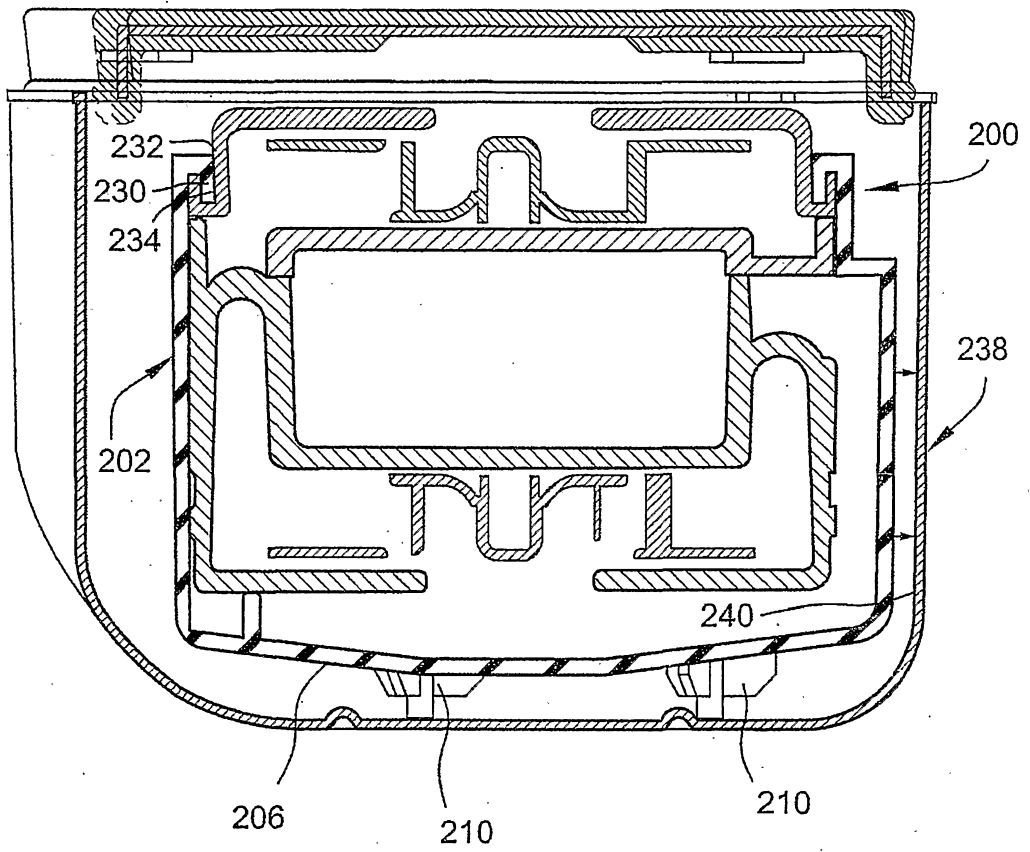

Fig. 21

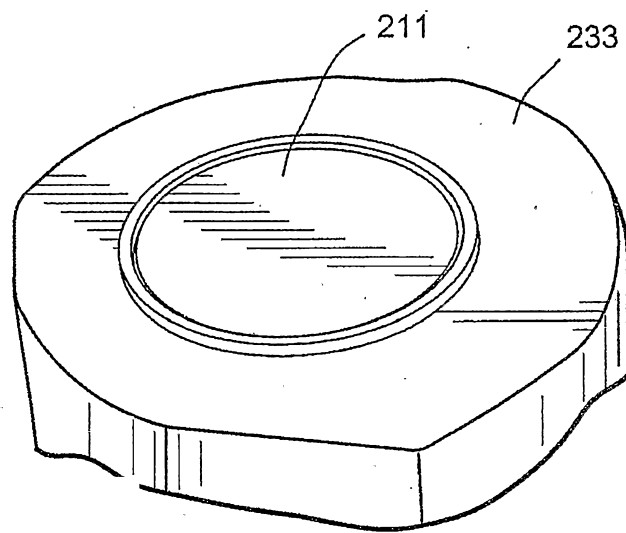

Fig. 22

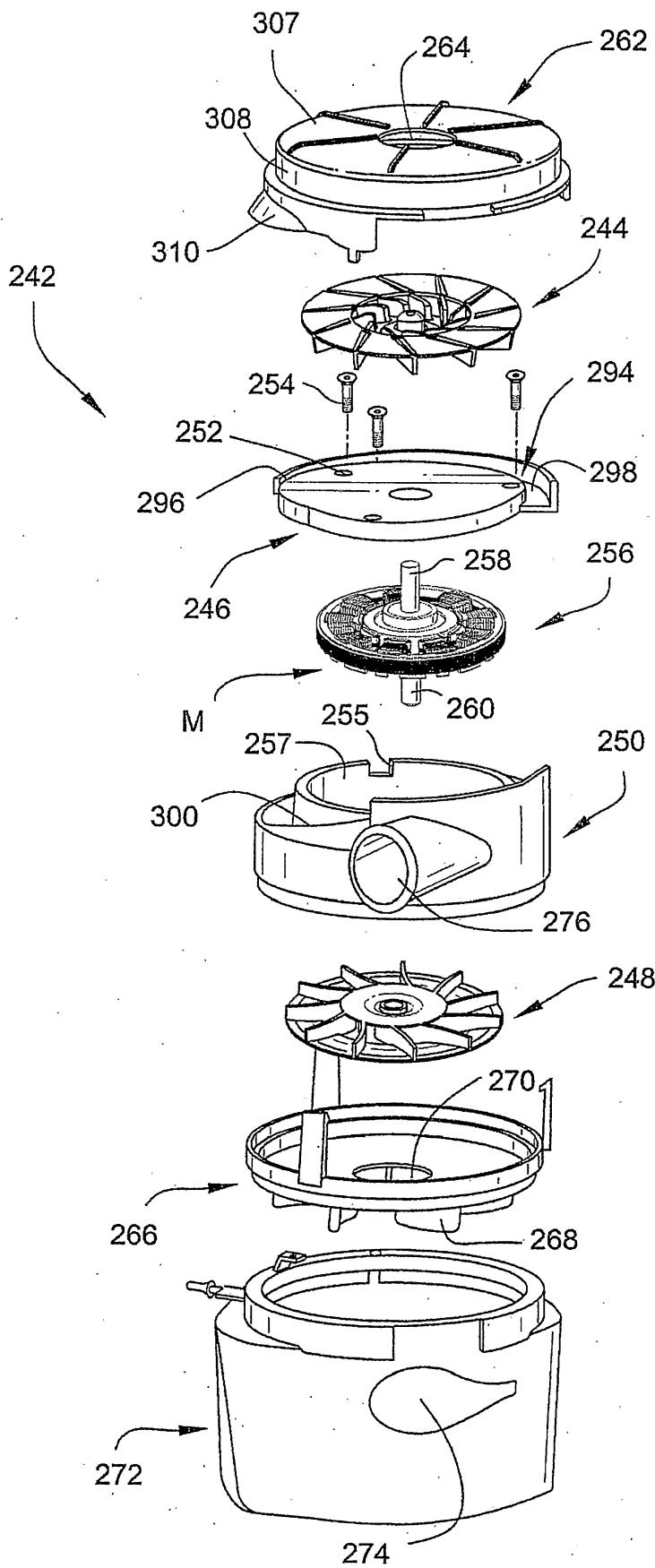

Fig. 23

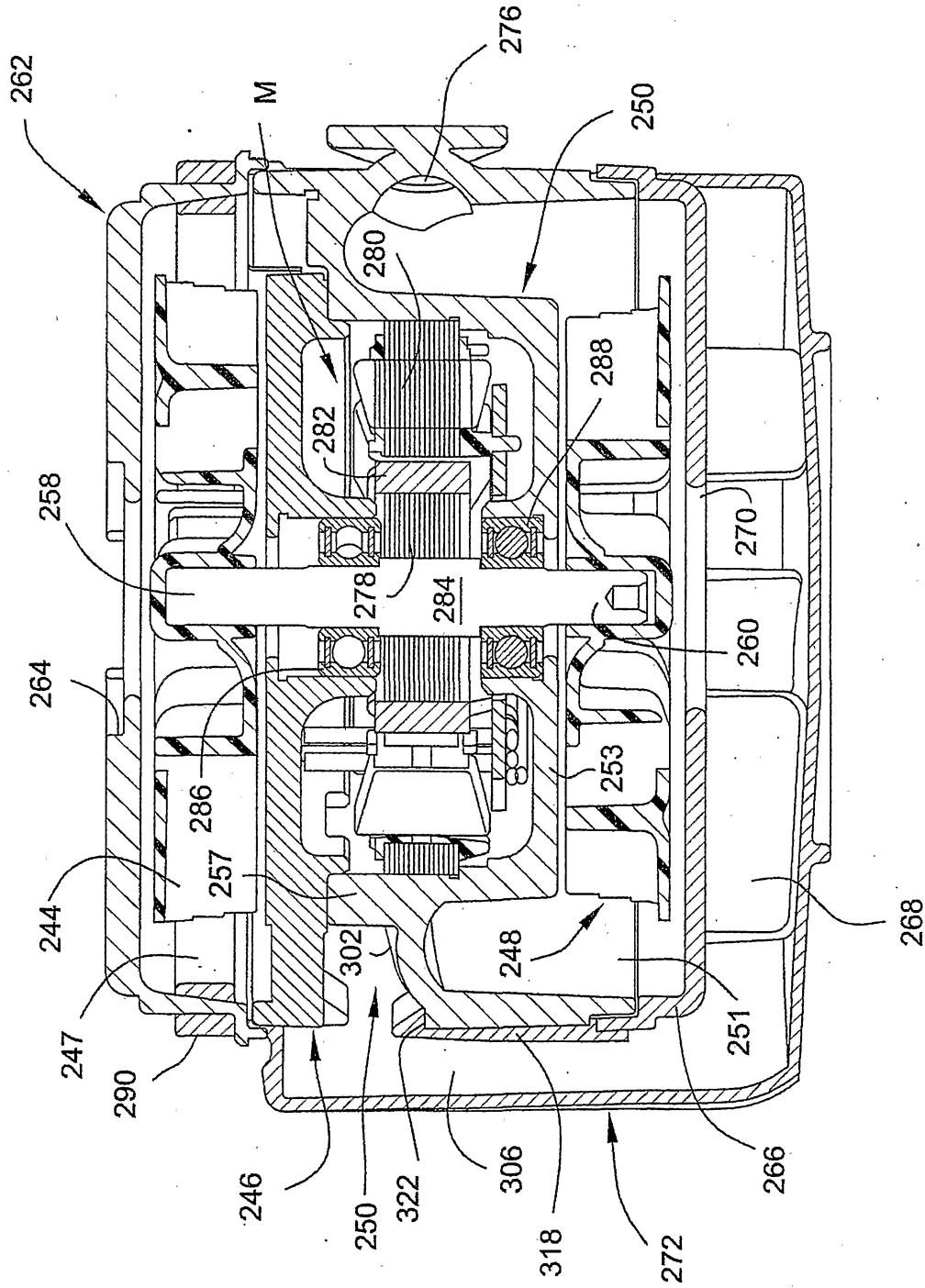

Fig. 24

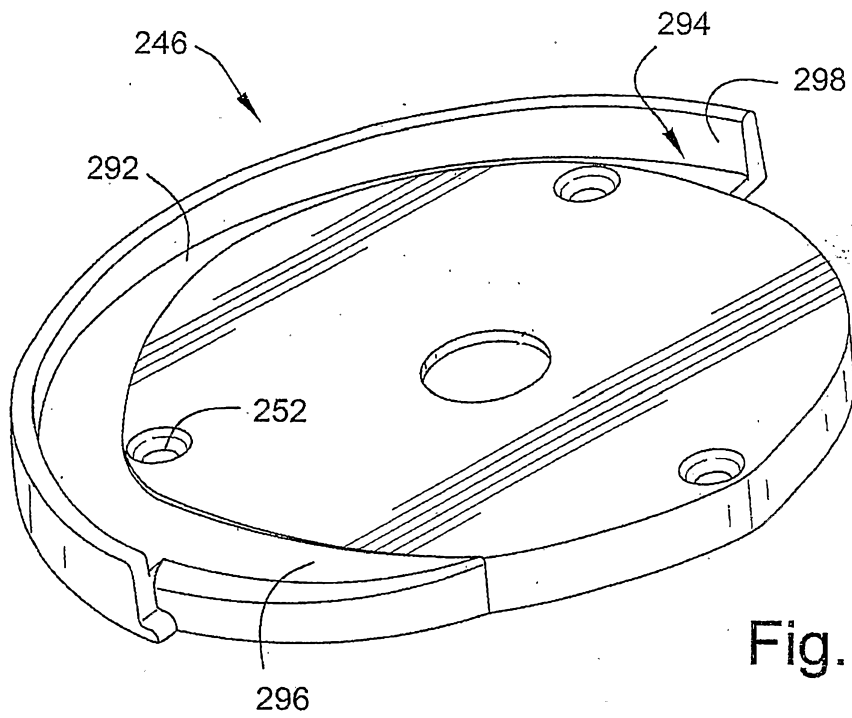

Fig. 25

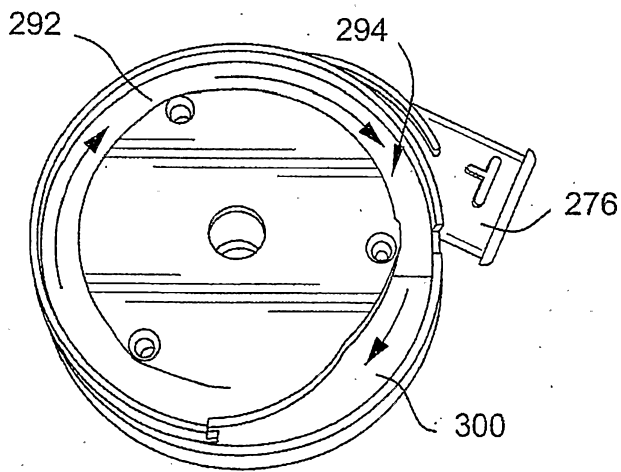

Fig. 26

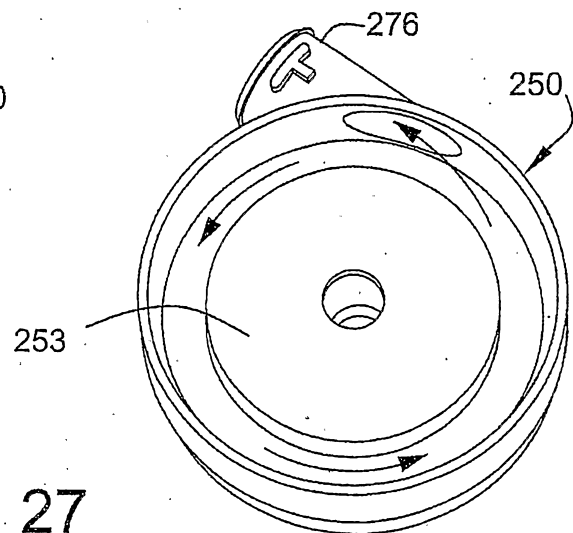
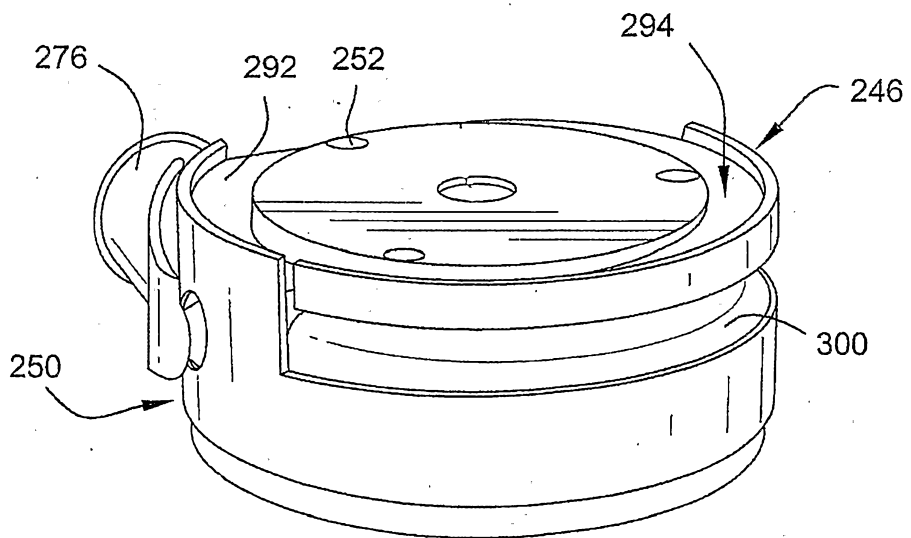
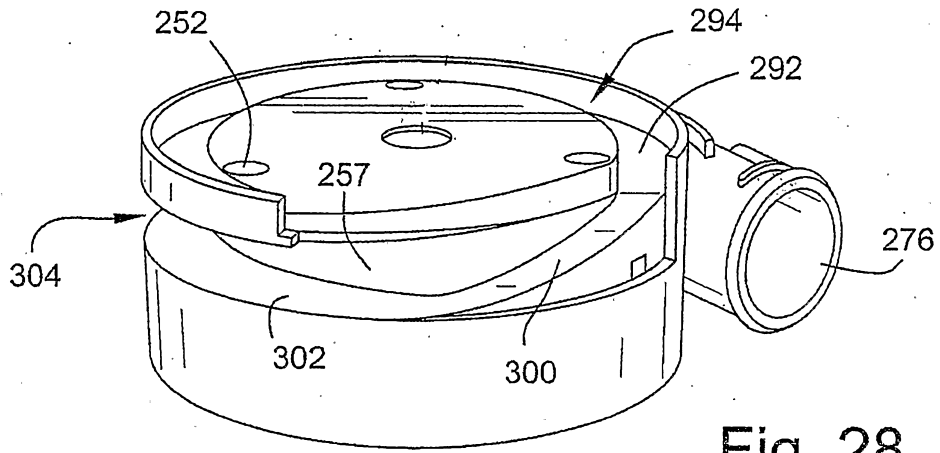

Fig. 27



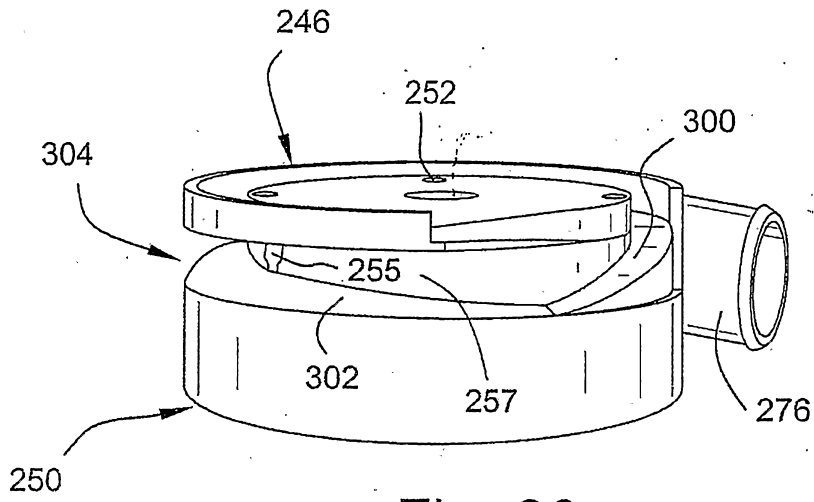

Fig. 30

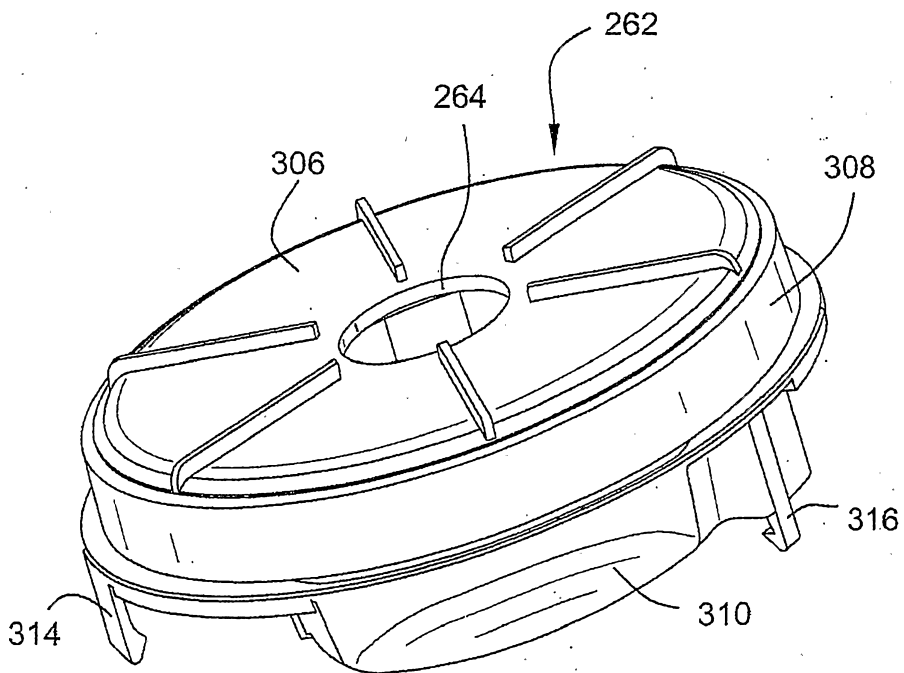

Fig. 31

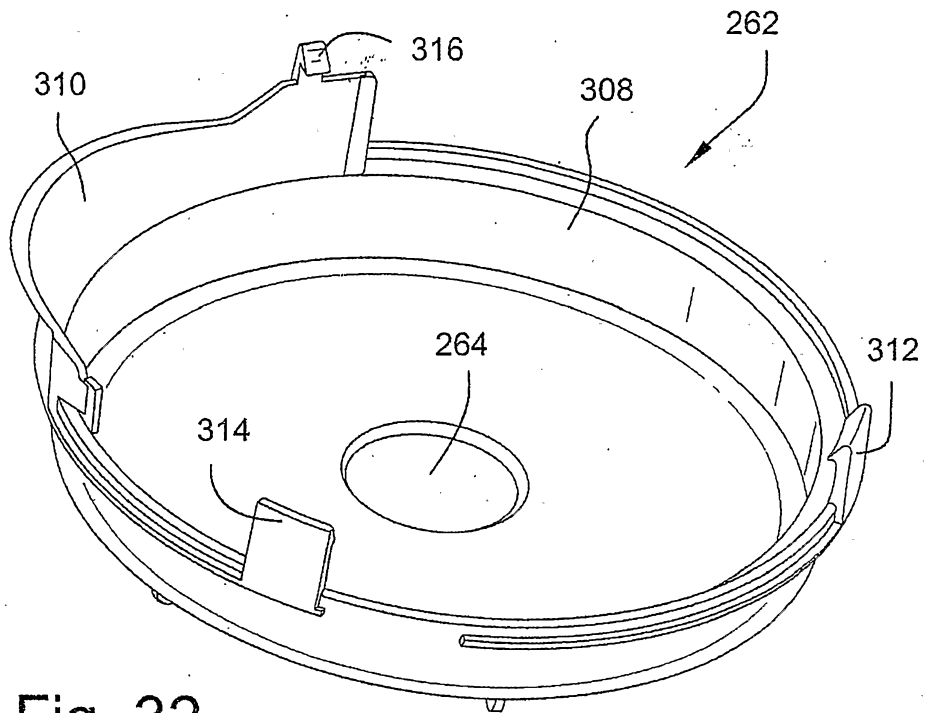

Fig. 32

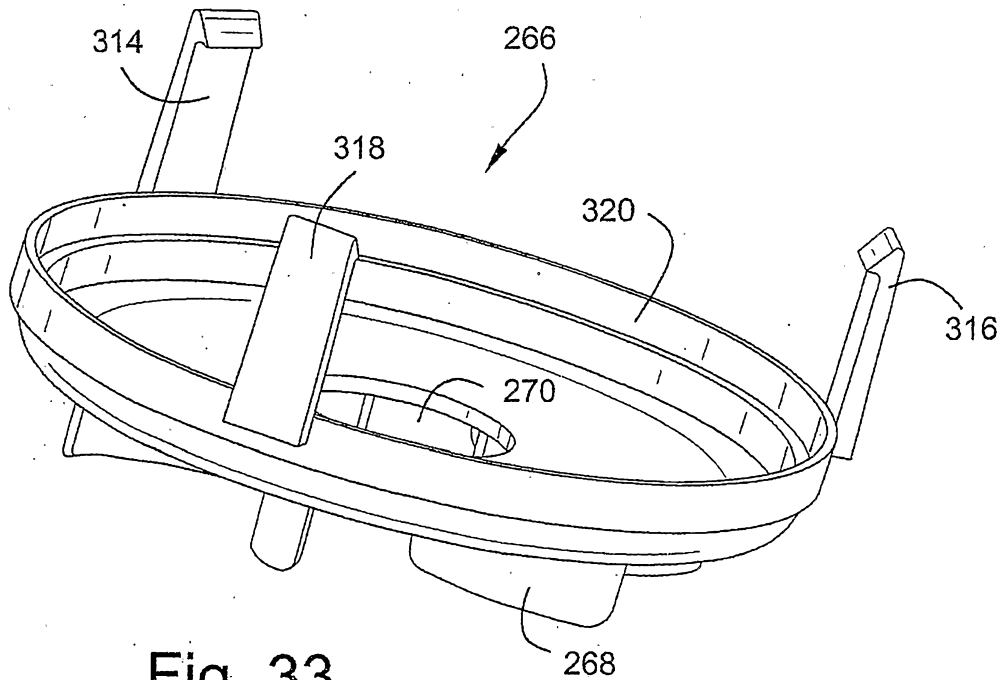

Fig. 33

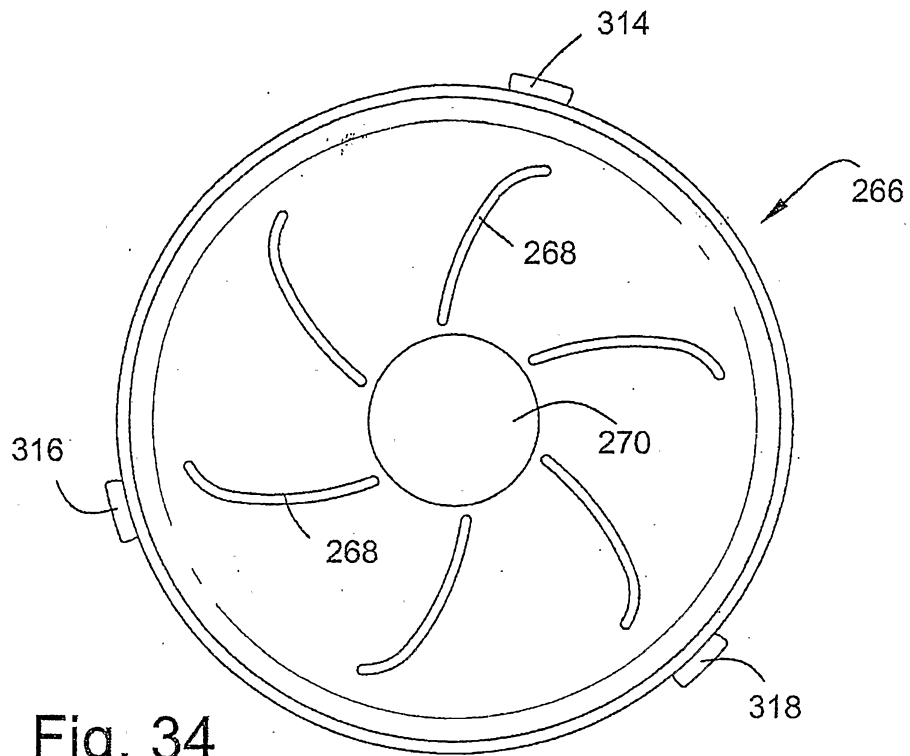

Fig. 34

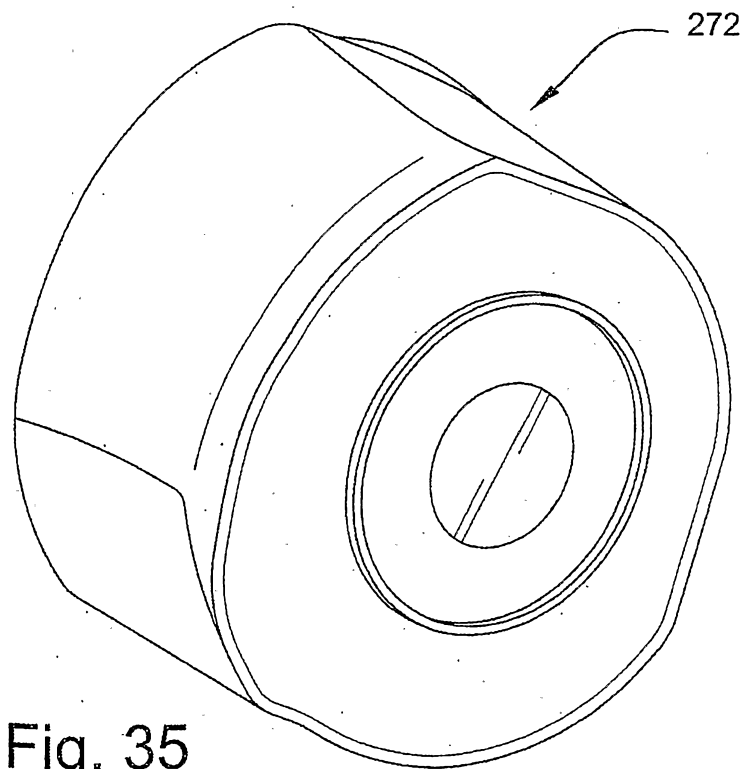

Fig. 35

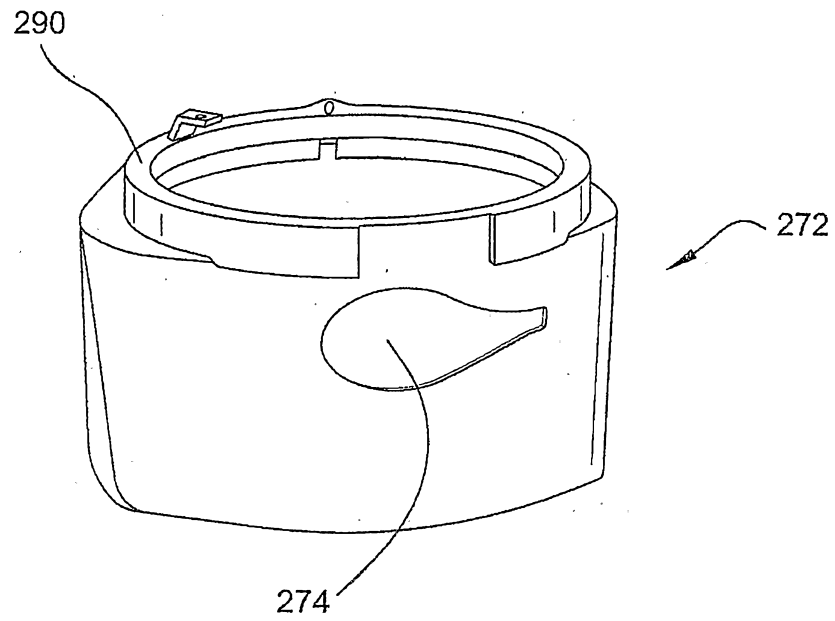

Fig. 36