

[54] COLLAPSIBLE SPEAKER EXTENSION

[76] Inventor: James A. Carruthers, P.O. Box 40, Warrenton, Oreg. 97146

[22] Filed: Apr. 19, 1974

[21] Appl. No.: 462,373

[52] U.S. Cl. 181/178, 181/152, 181/30

[51] Int. Cl. G10k 11/10

[58] Field of Search 181/178, 189, 190, 152, 181/30, 182

[56] References Cited

UNITED STATES PATENTS

753,417	3/1904	Mitchell.....	181/178
1,211,584	1/1917	Hooley.....	181/178
1,891,968	12/1932	Bidwell et al.....	181/152
1,920,631	8/1933	Coumbopoulos.....	181/178

Primary Examiner—Stephen J. Tomsky
 Attorney, Agent, or Firm—Kolisch, Hartwell,
 Dickinson & Stuart

[57] ABSTRACT

A collapsible extension for an acoustical speaker including a substantially planar top and a pair of opposed sides hingedly connected to opposite edge margins of the top. Each of the sides comprises at least a pair of panels hingedly interconnected at a pair of their adjacent edges. Each side is adapted to be collapsed by folding one panel back against the other and swinging the panels into a position adjacent and parallel to the top. In operation, the side panels are swung outwardly into planes extending in a common direction away from the top. Bracing members interposed between opposite sides are operable to maintain a pre-selected distance between the sides. Tension members, such as screw rods, interconnect the opposed sides and are operable to urge them toward each other, both to clamp the sides against opposite side margins of a speaker, and further to tighten the side margins against the bracing members to rigidify the structure.

14 Claims, 6 Drawing Figures

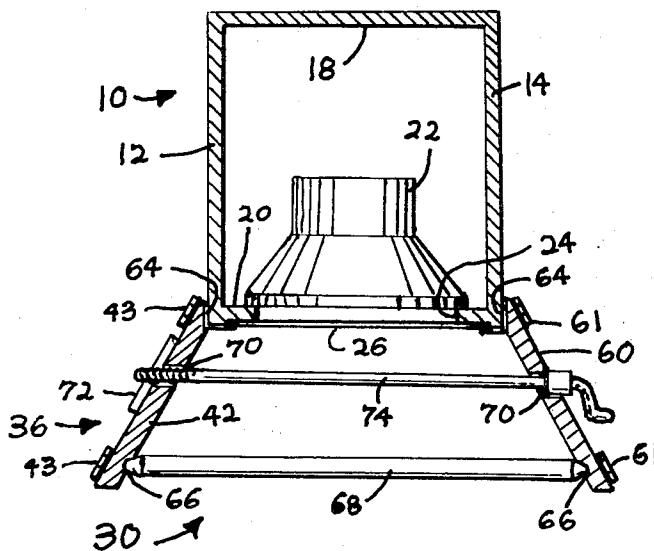

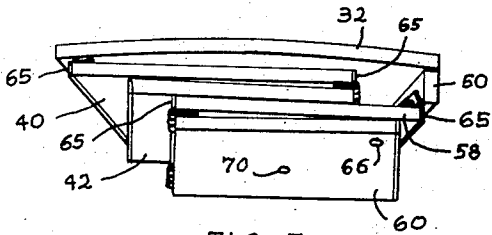

FIG. 5

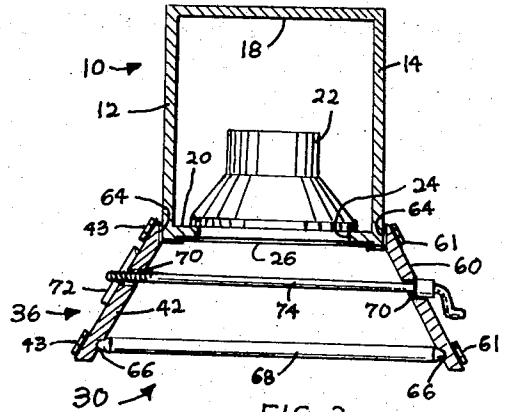

FIG. 2

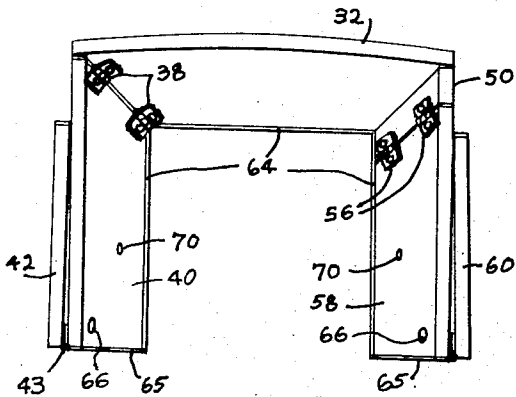

FIG. 4

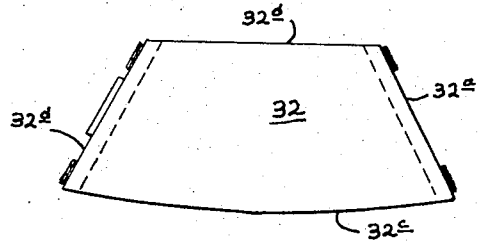

FIG. 6

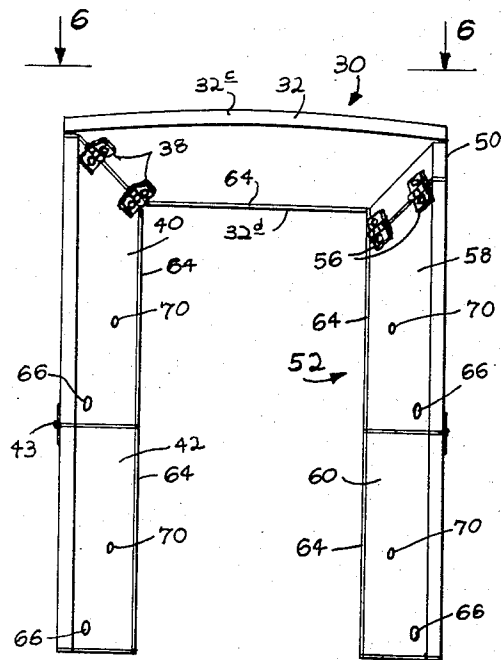

FIG. 3

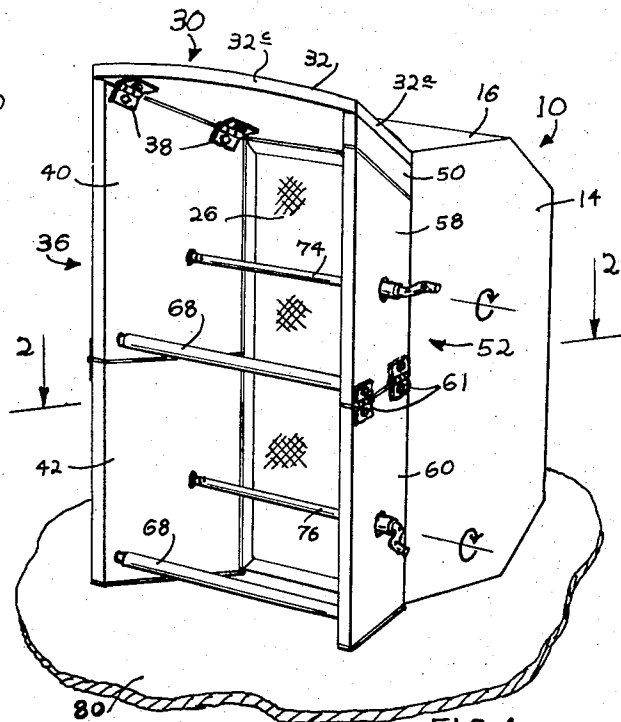

FIG. 1

COLLAPSIBLE SPEAKER EXTENSION

BACKGROUND AND SUMMARY OF THE INVENTION

This invention relates to a collapsible extension for an acoustical speaker.

Conventional acoustical speaker enclosures when used allow a large part of the sound wave front exiting from the enclosure to bend around the sides of the enclosure resulting in the destruction of much of the wave front. Only a relatively small portion of the original wave front, particularly in the lower range, thus is effectively propagated freely away from the enclosure.

It has been discovered that the performance of acoustical speakers housed in enclosures may be improved by the addition thereto of extensions having walls which diverge on progressing outwardly from the front of the speaker. Various extensions have been devised in the past, however, such generally have been rather cumbersome to handle and thus have not been acceptable to the industry because they are not easily packed and carried from place to place. Such packing and carrying often is required by musical, or other, groups who travel between engagements in different locales.

A general object of the present invention is to provide a novel extension for an acoustical speaker which controls the propagation of sound wave fronts leaving the enclosure whereby the wave front when it leaves the extension is considerably larger than when it left the enclosure and thus breaks up less providing a larger portion to propagate freely into the atmosphere.

Another object is to provide such an extension for an acoustical speaker which, when in operative condition, is large enough to surround the front of a speaker enclosure, yet which may be collapsed to a compact storage condition without having to be broken into several different parts.

More specifically, an object is to provide such an extension for an acoustical speaker in which a pair of opposed sides are hingedly connected to a planar top and the sides are swingable between operative positions extending outwardly in a common direction from the top and stored positions folded closely adjacent a planar surface of the top.

A still further object is to provide such an extension for an acoustical speaker wherein a side includes a plurality of side panels hingedly connected to each other which may be folded over against each other for yet more compact storage of the assembly.

Yet another object is to provide an extension for an acoustical speaker which includes substantially rigid spacer members extending between opposed sides of the extension, and tensioning members interconnecting opposite sides and operable to draw the two sides tightly together against the spacer members thus to provide additional rigidity in the structure and further to provide clamping of the sides of the extension against the sides of the speaker enclosure with which it is to be used.

Another object is to provide a relatively inexpensive self-contained horn-type extension, or projector, for an acoustical speaker which will readily fit on the front of an existing speaker cabinet to provide noticeable increase in sound output and projection and improvement in tonal quality, yet which, when not in use, can be folded down into a relatively compact package for

carrying and storage. No tools are required for installation and no modifications of existing speaker required.

DRAWINGS

These and other objects and advantages will become more fully apparent when the following description is read in conjunction with the drawings, wherein:

FIG. 1 is a perspective view of an extension constructed according to an embodiment of the invention secured to the front of a speaker enclosure;

FIG. 2 is a cross-sectional view taken generally along the line 2—2 in FIG. 1;

FIG. 3 is a front elevation view of the extension removed from a speaker;

FIGS. 4 and 5 are illustrations of sequential steps in folding the extension for storage or carrying; and

FIG. 6 is a top plan view of the extension taken along the line 6—6 in FIG. 3.

DETAILED DESCRIPTION OF AN EMBODIMENT OF THE INVENTION

Referring to the drawings, and particularly to FIGS. 1 and 2, at 10 is indicated generally a speaker enclosure having opposed upright sidewalls 12, 14, a top 16, a rear wall 18, and a front wall 20. Front wall 20 may mount a forwardly facing speaker 22. An opening, such as that indicated generally at 24 in FIG. 2, is provided in front wall 20 through which sound waves may emanate from speaker 22. Conventional grill cloth 26 may be secured over front wall 20 and opening 24 for decorative effect. The extension of the invention also may be used on speaker enclosures wherein the speaker faces rearwardly in the enclosure and the enclosure acts as a progressively expanding dual horn (also known as a folded W type horn) for projecting sound emanating from the speaker through the front of the speaker.

At 30 is indicated generally an extension constructed according to an embodiment of the invention. The extension includes a substantially, planar, rigid top member 32 having opposed side edge margins indicated generally at 32a, 32b, a front edge margin indicated generally at 32c and a rear edge margin indicated at 32d. As is seen in FIG. 6, side edge margins 32a, 32b diverge on progressing from rear edge margin 32d toward front edge margin 32c. The rear edge 32d has a length which is slightly greater than the side-to-side dimension of speaker enclosure 10.

A side 36 is pivotally connected to top 32 by a pair of hinges 38. Side 36 comprises a pair of substantially rigid, planar side panels, or sections, 40, 42. As is best seen in FIG. 1, side panel 40 has substantially parallel front and rear marginal edges and a lower marginal edge which extends substantially normal to its front and rear edges. The top edge margin of panel 40, however, is inclined and diverges away from the lower edge margin of the panel as it progresses from the rear edge of panel 40 to its forward edge. The maximum length, or height, of panel 40 is less than the side-to-side dimension of top member 32.

Lower side panel 42 is substantially rectangular and is hingedly connected at its upper edge to the lower edge margin of panel 40 by hinges, such as hinge 43 seen in FIGS. 2—5. The hinge connection between panel 40 and top 32 is such that side 36 may be folded upwardly and inwardly toward the underside of top member 32 with the inner face of panel 40 fitting sub-

stantially flush against the underside of top member 32. Panel 42 is hingedly connected to the lower edge of panel 40 in such a manner that it may be folded back against the planar side of panel 40 facing away from top member 32.

Secured to the underside of side margin 32a of top member 32 is an elongate, rigid, spacer 50 which projects substantially normally outwardly from the underside of top member 32. The height of member 50, from its top edge margin which joins to top member 32 to its lower edge margin, is substantially equal to, or slightly greater than, the combined thicknesses of panels 40, 42.

Another side for the extension, indicated generally at 52 is hingedly connected to spacer 50 by hinges 56. Side 52 includes a pair of substantially rigid planar panels, or sections, 58, 60. panel 58 has opposed, upright, substantially parallel forward and rear edges, and a lower edge which extends substantially normally between its forward and rear edges. The upper edge of panel 58 inclines upwardly, and thus diverges, from its lower margin as it progresses from its rear toward its forward edge. The total height of panel 58 is somewhat less than the total height of panel 40 spaced opposite it in the structure. Panel 60 is substantially rectangular and has substantially the same dimensions as its opposite panel 42 in the structure.

The rear marginal edge of side 36, and the total height of the rear marginal edges of side 52 and spacer 50, each are substantially equal to the height of speaker enclosure 10.

As is best seen in FIG. 1, panel 60 is hingedly connected adjacent its upper edge by hinges 61 to the lower edge of panel 58. The hinge connection between panel 58 and spacer 50 permits side 52 to be swung upwardly and inwardly toward the underside of top member 32. The hinge connection between panels 58, 60 permits panel 60 to be swung outwardly and against the outer side of panel 58.

Strips of sponge rubber, or other suitable elastomeric material, indicated generally at 64 in FIGS. 3 and 4, are secured to the rear, inwardly facing edge margins of top member 32 and sides 36, 52 and bottom edge margins of panels 42, 60 to provide an airtight seal between the speaker extension and the existing speaker and between the speaker extension and the floor. Strips of firmer rubber 65, or other suitable elastomeric material, (see FIGS. 4 and 5) are secured to the upper and lower edges of side panels 40, 58 to provide substantially airtight seals between adjacent sections in the structure and to provide compressive stress in the hinge joints to prevent rattles when in the operative positions shown in FIGS. 1 and 3.

Referring to FIG. 3, it will be seen that panels 40, 42, 58, 60 have depressions 66 formed on their inner surfaces adjacent their forward marginal edges. Elongate rigid bracing rods, or spacers, 68 having rounded ends are adapted to extend between and seat within opposed depressions in the panels when the extension is set up in its operative condition as illustrated in FIGS. 1 and 2.

Panels 40, 42, 58, 60 also have bores 70 extending therethrough at intermediate regions of the panels. As is seen in FIG. 2, a plate-like nut 72 having a threaded bore extending therethrough is secured to the outer side of each of panels 40, 42 with the bore in nut 72 aligned with a bore 70 in its associated panel.

An elongate crank rod 74, also referred to herein as a tensioning means, extends through aligned bores 70 in opposed panels 40, 58 and another crank rod 76 extends through aligned bores 70 in panels 42, 60, and the threaded ends of these rods are screwed into nuts 72. Turning of the rods 74, 76 acts to urge the sides of the speaker toward each other to clamp them against opposite ends of spacers 68.

Explaining the operation of the extension, and referring specifically to FIGS. 1 and 3, sides 36, 52 are swung to their operative positions extended outwardly from top member 32 and they are positioned with their rear marginal edges on opposite sides of the front of speaker enclosure 12 with, for example, an overlap of 2-3 inches between the extension and the enclosure where the speaker enclosure has generally height, width and depth dimensions in the neighborhood of 48", 24", and 22", respectively. The edge margin of top member 32 rests on the top of the upper edge of enclosure 10. Spacer members 68 are placed in depressions 66 on the inner faces of the side panels. Crank rods 74, 76 are inserted through bores 70 in the side panels and are screwed into nuts 72 to urge the side panels toward each other. As the side panels are urged toward each other, the inner surfaces of the rear margins of the side panels are clamped tightly against opposite sides of the speaker enclosure. As the crank rods are tightened, the top member also is pressed against the top of the enclosure to provide a tight fit therebetween. The sponge rubber strips 64 provide a substantially airtight connection between the speaker extension and the enclosure and between the speaker extension and the floor. Turning of crank handles 74, 76 also draws the side panels tight against spacers 68 to add further rigidity to the extension and also stresses the individual side panels for additional stiffness and helps prevent rattles occurring at the hinge joints. The firm rubber strips at the hinge joints in the structure aid in the tensing of the extension structure to prevent rattles as well as provide more airtight seals between the joints.

With the speaker enclosure and extension resting on a floor, or other supportive surface, 80 a projector horn surrounding the face of the speaker enclosure is formed.

Thus, in its operative position, the extension provides a substantially rigid, horn-type projector for improving the sound output, projection, and tonal quality of the speaker. It also improves loudspeaker loading to reduce distortion of tone and prolong speaker life.

To fold the extension for storage or carrying, crank rods 74, 76 are unscrewed and removed, spacers 68 are removed, and thereafter the extension may be folded as illustrated in the sequential steps of FIGS. 3, 4 and 5. Explaining further, and referring to FIG. 4, after removal of rods 74, 76 and spacers 68, panels 42, 60 are folded back against the outer surfaces of panels 40, 58, respectively. Panels 40, 42 then are swung together upwardly and inwardly against the underside of panel 32 as seen in FIG. 5. Panels 58, 60 are swung together upwardly and inwardly against the underside of panel 42, as shown in FIG. 5.

While a preferred embodiment of the invention has been described herein, it should be apparent to those skilled in the art that variations and modifications are possible without departing from the spirit of the invention.

It is claimed and desired to secure by Letters Patent:

1. A collapsible extension for an acoustical speaker comprising a substantially planar top member having opposed marginal edge portions, a first side pivotally connected to one of said edge portions and a second side pivotally connected to the opposite edge portion of said top member, said first and second sides being swingable toward and away from each other between operative positions disposed at substantial angles relative to said top member and extending outwardly in a common direction from the top member and closed positions disposed substantially parallel to and adjacent said top member, substantially rigid spacer means insertable between said sides when said sides are in their operative positions, operable to inhibit swinging of said sides toward each other to maintain a preselected spacing therebetween, and detachable tension means interconnecting said sides operable to draw said sides toward each other and hold them against said spacer means.

2. The extension of claim 1, wherein a side includes a plurality of substantially planar, adjacent side sections hingedly interconnected along an adjacent set of edge margins thereof permitting said sections to swing relative to each other between an operative position extending outwardly in opposite directions from said hinge connection therebetween to lie in a substantially common plane, and a storage position folded back against each other.

3. The extension of claim 2, wherein one of said sections is hingedly connected to said top member along an edge of said section opposite its edge which is hingedly connected to said other section.

4. The extension of claim 1, wherein said opposed sides and said spacer means include means thereon for securing said spacer means against removal when said tension means is operative to hold said sides against said spacer means.

5. The extension of claim 3, wherein said sectionalized side when swung to its stored position is disposed contiguous a planar surface of said top member and the other of said sides is hingedly connected in a region spaced from said top member a distance substantially equal to the combined thickness of said plurality of sections of the sectionalized side when folded together, whereby when the extension is collapsed said sectionalized side is stored intermediate said top member and said other side, with said top member and other side disposed substantially parallel.

6. The extension of claim 1, wherein said opposed edge margins of the top member diverge on progressing in one direction and said sides when in their operative positions diverge from each other on progressing in said one direction.

7. The extension of claim 1, for use with a speaker having a certain height and width, the distance between said sides of the extension at their most closely spaced edges when in their operative positions being substantially equal to the width of the speaker and the height of said sides along said edges being substantially equal to the height of said speaker, whereby the extension may receive a forward portion of said speaker between said sides, with operation of said tension means being operable to clamp the extension onto said speaker.

8. The extension of claim 1, which further comprises elongate, elastomeric strips are interposed between

edge margins of said sides and said top member when said sides are in their operative position.

9. The extension of claim 2, which further comprises an elongate, elastomeric strip interposed between contiguous edge margins of said side sections when in their operative position.

10. A collapsible extension for an acoustical speaker having opposed side margins and a top margin framing the front of the speaker, said extension comprising

- a substantially planar top member,
- a pair of opposed sides pivotally connected to said top member adjacent opposite edges thereof for swinging toward and away from each other between operative positions disposed at substantial angles relative to said top member and extending outwardly in a common direction from the top member and closed positions disposed substantially parallel to and adjacent said top member, said sides, when in their operative positions, having rear edge margins which are spaced apart a distance substantially equal to the width of opposed side margins of the speaker,

detachable spacer means extending between said opposed sides adjacent the front edge margins of the sides to inhibit swinging of said sides toward each other and to maintain a preselected spacing therebetween when said sides are in their operative positions, and

detachable tension means interconnecting said sides adjacent their rear edge margins for drawing said sides toward each other and clamping them against opposite side margins of the speaker.

11. The extension of claim 10, wherein said tension means comprises a screw device connected adjacent one of its ends to one of said sides, and connected adjacent its opposite end to the other of said sides, which screw device is operable upon turning in one direction to urge said sides toward each other.

12. The speaker of claim 10, wherein said sides are connected to said top member in such a manner that they diverge relative to each other on progressing from their rear edge margins toward their front edge margins.

13. The extension of claim 10, wherein said top member is connected to said sides in such a manner that when said extension is secured to a speaker the top inclines upwardly on progressing forwardly and away from the speaker.

14. A collapsible extension for an acoustical speaker having laterally spaced, substantially parallel side margins, said extension comprising a pair of opposed, substantially planar side panels having laterally spaced rear edge margins adapted to engage said opposed side margins of the speaker with remainder portions of said side panels projecting outwardly in a substantially common direction from said speaker, detachable spacer means extending between said opposed side panels adjacent their front set of edge margins operable to prevent movement of said front edge margins of the side panels toward each other beyond a preselected lateral spacing to maintain such a preselected spacing between said sides, and detachable tension means interconnecting said side panels intermediate their front and rear edge margins for urging said side panels toward each other to clamp their rear edge margins against opposite side margins of the speaker.

* * * * *