



(86) Date de dépôt PCT/PCT Filing Date: 2007/06/21
 (87) Date publication PCT/PCT Publication Date: 2007/12/27
 (85) Entrée phase nationale/National Entry: 2008/12/04
 (86) N° demande PCT/PCT Application No.: US 2007/071798
 (87) N° publication PCT/PCT Publication No.: 2007/149989
 (30) Priorité/Priority: 2006/06/21 (US60/815,502)

(51) Cl.Int./Int.Cl. *A61B 17/00* (2006.01)
 (71) Demandeur/Applicant:
 COOK INCORPORATED, US
 (72) Inventeurs/Inventors:
 OBERMILLER, F. JOSEPH, US;
 CHEN, STEVE, US
 (74) Agent: SMART & BIGGAR

(54) Titre : GREFFONS POUR FISTULE ET PROCEDES ET SYSTEMES UTILES POUR TRAITER DES FISTULES
 GASTRO-INTESTINALES
 (54) Title: FISTULA GRAFTS AND RELATED METHODS AND SYSTEMS USEFUL FOR TREATING
 GASTROINTESTINAL FISTULAE



Fig. 1B

(57) **Abrégé/Abstract:**

Described are medical graft products, systems, and methods useful for treating fistulae, particularly enterocutaneous fistulae. Certain products of the invention are configured to have portions residing in and around a primary fistula opening in a wall of the alimentary canal. One such product includes a biocompatible graft body which is configured to block at least the primary opening. The graft body includes a capping member connected to an elongate plug member. The capping member is configured to contact portions of the alimentary canal wall adjacent to the primary opening, and the elongate plug member is configured to extend into at least a portion of the fistula. A graft product of this sort may be particularly adapted to allow a portion of the capping member to be positioned alongside an exterior, lateral surface of the plug member, e.g., when placed in a delivery device lumen. Such a capping member may be hingedly or non-hingedly coupled to the elongate plug member.

(12) INTERNATIONAL APPLICATION PUBLISHED UNDER THE PATENT COOPERATION TREATY (PCT)

(19) World Intellectual Property Organization
International Bureau(43) International Publication Date
27 December 2007 (27.12.2007)

PCT

(10) International Publication Number
WO 2007/149989 A3(51) International Patent Classification:
A61B 17/00 (2006.01)

(21) International Application Number:

PCT/US2007/071798

(22) International Filing Date: 21 June 2007 (21.06.2007)

(25) Filing Language: English

(26) Publication Language: English

(30) Priority Data:

60/815,502 21 June 2006 (21.06.2006) US

(71) Applicant (for all designated States except US): **COOK INCORPORATED** [US/US]; 750 Daniels Way, Bloomington, IN 47404 (US).

(72) Inventors; and

(75) Inventors/Applicants (for US only): **OBERMILLER, F., Joseph** [US/US]; 1906 Blueberry Lane, West Lafayette, IN 47906 (US). **CHEN, Steve** [US/US]; 1926 Bayley Drive, Apt. 153, Lafayette, IN 47905 (US).(74) Agents: **NAUGHTON, Joseph, A.** et al.; Woodard, Emhardt, Moriarty, Mcnett, & Henry LLP, 111 Monument Circle; Suite 3700, Indianapolis, IN 46204 (US).

(81) Designated States (unless otherwise indicated, for every kind of national protection available): AE, AG, AL, AM, AT, AU, AZ, BA, BB, BG, BH, BR, BW, BY, BZ, CA, CH, CN, CO, CR, CU, CZ, DE, DK, DM, DO, DZ, EC, EE, EG, ES, FI, GB, GD, GE, GH, GM, GT, HN, HR, HU, ID, IL, IN, IS, JP, KE, KG, KM, KN, KP, KR, KZ, LA, LC, LK, LR, LS, LT, LU, LY, MA, MD, ME, MG, MK, MN, MW, MX, MY, MZ, NA, NG, NI, NO, NZ, OM, PG, PH, PL, PT, RO, RS, RU, SC, SD, SE, SG, SK, SL, SM, SV, SY, TJ, TM, TN, TR, TT, TZ, UA, UG, US, UZ, VC, VN, ZA, ZM, ZW.

(84) Designated States (unless otherwise indicated, for every kind of regional protection available): ARIPO (BW, GH, GM, KE, LS, MW, MZ, NA, SD, SL, SZ, TZ, UG, ZM, ZW), Eurasian (AM, AZ, BY, KG, KZ, MD, RU, TJ, TM), European (AT, BE, BG, CH, CY, CZ, DE, DK, EE, ES, FI, FR, GB, GR, HU, IE, IS, IT, LT, LU, LV, MC, MT, NL, PL, PT, RO, SE, SI, SK, TR), OAPI (BF, BJ, CF, CG, CI, CM, GA, GN, GQ, GW, ML, MR, NE, SN, TD, TG).

Published:

— with international search report

(88) Date of publication of the international search report:

25 September 2008

(54) Title: FISTULA GRAFTS AND RELATED METHODS AND SYSTEMS USEFUL FOR TREATING GASTROINTESTINAL FISTULAE

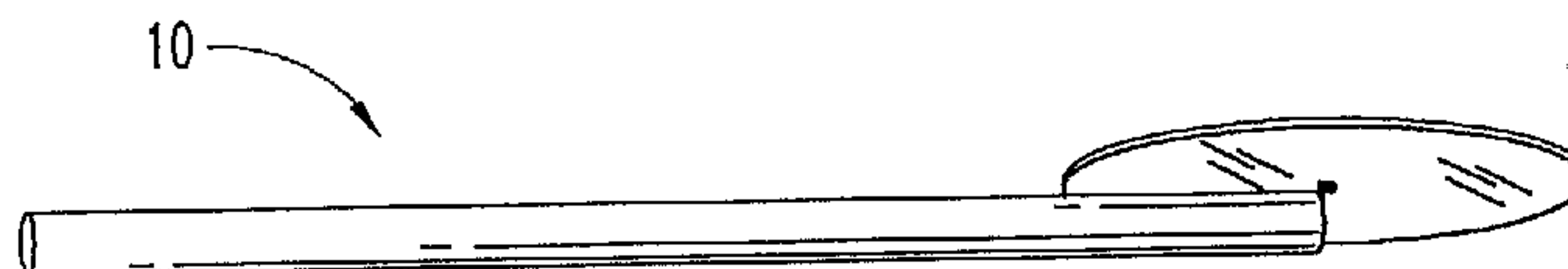
**Fig. 1B**

(57) Abstract: Described are medical graft products, systems, and methods useful for treating fistulae, particularly enterocutaneous fistulae. Certain products of the invention are configured to have portions residing in and around a primary fistula opening in a wall of the alimentary canal. One such product includes a biocompatible graft body which is configured to block at least the primary opening. The graft body includes a capping member connected to an elongate plug member. The capping member is configured to contact portions of the alimentary canal wall adjacent to the primary opening, and the elongate plug member is configured to extend into at least a portion of the fistula. A graft product of this sort may be particularly adapted to allow a portion of the capping member to be positioned alongside an exterior, lateral surface of the plug member, e.g., when placed in a delivery device lumen. Such a capping member may be hingedly or non-hingedly coupled to the elongate plug member.

WO 2007/149989 A3

**FISTULA GRAFTS AND RELATED METHODS AND SYSTEMS USEFUL
FOR TREATING GASTROINTESTINAL FISTULAE**

REFERENCE TO RELATED APPLICATION

5

The present application claims the benefit of United States Provisional Patent Application Serial No. 60/815,502 filed June 21, 2006, entitled "Fistula Grafts and Related Methods and Systems Useful For Treating Gastrointestinal Fistulae" which is hereby incorporated by reference in its entirety.

10

BACKGROUND

The present invention relates generally to medical devices and in particular aspects to medical products and methods for treating fistulae.

15

As further background, a variety of fistulae can occur in humans. These fistulae can occur for a variety of reasons, such as but not limited to, as a congenital defect, as a result of inflammatory bowel disease, such as Chron's disease, irradiation, trauma, such as childbirth, or as a side effect from a surgical procedure. Further, several different types of fistulae can occur, for example, urethro-vaginal fistulae, vesico-vaginal fistulae, tracheo-esophageal fistulae, gastrointestinal fistulae, and any number of anorectal fistulae, such as recto-vaginal fistula, recto-vesical fistulae, recto-urethral fistulae, or recto-prostatic fistulae.

20

25

A gastrointestinal fistula is an abnormal passage that leaks the contents of the stomach or the intestine (small or large bowel) to other organs, usually other parts of the intestine or the skin. For example, gastrojejunocolic fistulae include both enterocutaneous fistulae (those occurring between the intestine, namely the duodenum, or the jejunum, or the ileum, and the skin surface) and gastric fistulae (those occurring between the stomach and skin surface). Another type of fistulae

30

occurring in the gastrointestinal tract is an enteroenteral fistula, which refers to fistulae occurring between two parts of the intestine. Gastrointestinal fistulae can result in malnutrition and dehydration depending on their location in the gastrointestinal tract. They can also be a source of skin problems and infection. The majority of these types of fistulae are the result of surgery (e.g., bowel surgery), although sometimes they can develop spontaneously or from trauma, especially penetrating traumas such as stab wounds or gunshot wounds. Inflammatory processes, such as infection or inflammatory bowel disease (Crohn's disease), may also cause gastrointestinal fistulae. In fact, Crohn's disease is the most common primary bowel disease leading to enterocutaneous fistulae, and surgical treatment may be difficult because additional enterocutaneous fistulae can develop in many of these patients postoperatively.

The path which these fistulae take, and their complexity, can vary. A fistula may take a "straight line" path from the primary to the secondary opening, known as a simple fistula. Alternatively, the fistula may consist of multiple tracts ramifying from the primary opening and have multiple secondary openings. This is known as a complex fistula.

Treatment options for gastrointestinal fistulae vary from patient to patient. Depending on the clinical situation, patients may require IV nutrition and a period of time without food to allow the fistula time to close on its own. Indeed, nonsurgical therapy may allow spontaneous closure of the fistula, though this can be expected less than 30% of the time. A variable amount of time to allow spontaneous closure of fistulas has been recommended, ranging from 30 days to 6 to 8 weeks. During this time, external control of the fistula drainage prevents skin disruption and may provide a guideline for fluid and electrolyte replacement. In some cases, surgery is necessary to remove the segment of intestine involved in a non-healing fistula.

When surgery is deemed necessary, the preferred operation for fistula closure is resection of the fistula-bearing segment and primary end-to-end anastomosis. The anastomosis may be reinforced by greater omentum or a serosal patch from adjacent small bowel. Still other methods for treating fistulae involve injecting sclerosant or sealant (e.g., collagen or fibrin glue) into the tract of the fistula to block the fistula. Closure of a fistula using a sealant is typically performed as a two-stage procedure, including a first-stage seton placement and injection of the fibrin glue several weeks later. This allows residual infection to resolve and to allow the fistula tract to "mature" prior to injecting a sealant. If sealant or sclerosant were injected as a one-stage procedure, into an "unprepared" or infected fistula, this may cause a flare-up of the infection and even further abscess formation.

There remain needs for improved and/or alternative medical products, methods, and systems that are useful for treating fistulae, particularly gastrointestinal fistulae. The present invention is addressed to those needs.

SUMMARY

The present invention provides, in certain aspects, unique medical products for treating fistulae having at least a primary opening in the alimentary canal and a fistula tract. Certain embodiments of the invention relate to fistula grafts which are configured to have portions residing in and around a primary fistula opening, such as a gastrointestinal fistula primary opening. For example, some inventive fistula grafts include a biocompatible graft body which is configured to block at least the primary fistula opening, wherein the graft body comprises a capping member and an elongate plug member, which extends from the capping member. The capping member is configured to contact portions of the alimentary canal wall adjacent to the primary opening, and the elongate plug member is configured to extend into at least a portion of the fistula tract. The capping member and the elongate plug member are formed separately and then coupled to one another (e.g., hingedly coupled with a suture) or otherwise suitably united, or alternatively, the two may be formed as a single unit, for example, from a single piece of material or other object. In this regard, each of the two members can exhibit any suitable size, shape, and configuration, and may be formed with one or more of a variety of suitable biocompatible materials. In some forms, the graft body is configured to seal off or substantially seal off the primary fistula opening when suitably deployed. The capping member and/or the elongate plug member, in certain aspects, comprise an expandable element, for example, an expandable material such as a compressed sponge material and/or an expandable device such as a resilient wire frame. In preferred aspects, the capping member and/or the elongate plug member comprise a remodelable, angiogenic material, for example, a remodelable extracellular matrix material such as submucosa. Further, the medical graft product, in some forms, can include a suture in association with the graft body. This suture can be used, for example, to draw the product into the fistula primary opening and/or to secure the product to soft tissues at or near a secondary opening in the fistula.

In one particular embodiment, the invention provides a method for treating a fistula having a primary opening in a wall of the alimentary canal and a fistula tract. This method comprises (i) providing a medical graft product including a biocompatible graft body that is configured to block at least the primary fistula opening, wherein the graft body includes a capping member and an elongate plug member extending from the capping member; said capping member being hingedly coupled to said elongate plug member and (ii) implanting the medical graft product within a patient so that the capping member contacts portions of the alimentary canal wall adjacent to the primary opening, and the elongate plug member extends into at least a portion of the fistula tract. In certain aspects, a suitably configured medical graft product is implanted so as to seal off or substantially seal off the primary opening. Further, the medical graft product may include an anchoring adaptation useful for maintaining the capping member in contact with portions of the alimentary canal wall adjacent to the primary opening. Suitable anchoring adaptations include but are not limited to adhesives (e.g., dried, reversible adhesives), barbs, hooks, sutures, and the like.

In another embodiment, the present invention provides a medical graft product useful for treating a fistula having a primary opening in a wall of the alimentary canal and a fistula tract. This medical graft product includes a biocompatible graft body configured to block at least the primary opening of the fistula. The graft body is comprised of a capping member and an elongate plug member. The plug member has a proximal and distal end, with a lumen extending therethrough. The capping member extends from the distal end of the elongate plug member, and is configured to contact portions of the alimentary canal wall adjacent to the primary opening. The elongate plug member is configured to extend into at least a portion of the fistula tract, and includes a plurality of passages. The longitudinal axis of each passage runs through the plug member lumen to allow communication between opposing sides of the exterior surface of the elongate plug member.

Another aspect of the present invention provides a graft product for treating a fistula, which is comprised of a graft body configured to reside in a tract of the fistula, and a capping member configured to contact tissues adjacent an opening of the fistula. The capping member is connected to an end region of the graft body, and includes a
5 portion positionable along an exterior lateral surface of the graft body.

In yet another aspect, the invention provides a medical graft product that is comprised of a capping member, and an elongate graft body extending from the capping member. The capping member includes a portion positionable over an
10 exterior lateral surface of the elongate graft body. This portion is conformable to the exterior lateral surface of the elongate graft body.

The present invention provides, in another embodiment, an apparatus for treating a fistula having at least an opening in a bodily structure wall and a fistula tract
15 extending from the opening. This apparatus comprises a delivery device having a lumen communicating with a distal end opening, wherein the delivery device is configured for passage through the fistula tract and the opening. The apparatus also comprises a medical graft device removably positioned in the delivery device lumen. The medical graft device is comprised of a biocompatible graft body, and includes a
20 capping member and an elongate plug member. The capping member is configurable to a first condition permitting at least part of the capping member to be positioned along an exterior lateral surface of the elongate plug member when in the delivery device lumen. The elongate plug member extends from the capping member, and is effective to fill at least a portion of the fistula tract.

25

Other objects, embodiments, forms, features, advantages, aspects, and benefits of the present invention shall become apparent from the detailed description and drawings included herein.

BRIEF DESCRIPTION OF THE DRAWINGS

Fig. 1A is a perspective view of an illustrative medical graft product in its original configuration including an elongate plug member and a capping member
5 hingedly coupled thereto.

Fig. 1B is a perspective view of the medical graft product illustrated in Fig. 1A where the capping member is folded over the elongate plug member to provide an intermediate configuration.
10

Fig. 1C is a perspective view of the medical graft product illustrated in Fig. 1B where the capping member is rolled around the elongate plug member to provide an implantable configuration.

Fig. 1D is a perspective view of the medical graft product in its implantable configuration as illustrated in Fig. 1C where the capping member is folded and rolled over the elongate plug member and is inserted into a sheath for delivery.
15

Fig. 1E is a perspective view of an illustrative medical graft product including an elongate body, a capping member, and a pull tether.
20

Figure 2A is a perspective view of a support frame useful in the present invention.

Figure 2B provides a perspective view of a capping member of the present invention.
25

Figure 3A is a perspective view of a medical graft device of the invention.

Figure 3B shows the medical graft device of Figure 3A implanted within a patient.

Figure 4A is a perspective view of a medical graft device of the invention.

5

Figure 4B is a partial, perspective view of the medical graft device of Figure 4A positioned in a delivery device lumen.

DETAILED DESCRIPTION

As disclosed above, in certain aspects, the present invention provides unique medical graft products and methods useful for treating fistulae having at least a fistula tract and a primary opening in the alimentary canal or other similar voids in bodily tissues. For example, some inventive graft products include a biocompatible graft body which is configured to block at least the primary fistula opening, wherein the graft body includes a capping member and an elongate plug member extending from the capping member. The capping member is configured to contact portions of the alimentary canal wall adjacent to the primary opening, and the elongate plug member is configured to extend into at least a portion of the fistula tract. The elongate plug member and the capping member are preferably formed separately and then coupled to one another by a coupling element. The biocompatible graft body preferably comprises a remodelable material, for example, a remodelable extracellular matrix material such as submucosa. The invention also provides methods utilizing such graft products and medical products that include such graft products enclosed within sterile packaging.

Graft materials useful in the medical graft products of the present invention can include any suitable biocompatible material. Generally, the graft materials may include a remodelable and/or resorbable material, such as a resorbable synthetic material or a naturally derived resorbable or remodelable material. Additionally, graft materials can include any other suitable naturally derived or any other suitable nonresorbable synthetic material, or any combination of any of the above such biocompatible materials. Such biocompatible materials that are at least bioresorbable will provide advantage in certain embodiments of the invention, with materials that are bioremodelable or otherwise tissue inductive so as to promote cellular invasion and ingrowth providing particular advantage. Illustratively, remodelable materials may be used in this context to promote cellular growth within the graft materials to promote healing and closure of at least the primary opening of a fistula.

Suitable materials for use in the invention can be provided by collagenous extracellular matrix (ECM) materials, including but not limited to those possessing biotropic or remodelable properties, including in certain forms angiogenic collagenous extracellular matrix materials. For example, suitable collagenous materials include ECM materials such as those comprising submucosa, renal capsule membrane, dermal collagen (including processed dermal collagen from human cadavers, which can be used as allograft in humans), dura mater, pericardium, fascia lata, serosa, peritoneum, or basement membrane layers, including liver basement membrane. Suitable submucosa materials for these purposes include, for instance, intestinal submucosa, including small intestinal submucosa, stomach submucosa, urinary bladder submucosa, and uterine submucosa. Some preferred medical graft products of the invention will include submucosa, such as submucosa derived from a warm-blooded vertebrate. Mammalian submucosa materials are preferred. In particular, submucosa materials derived from animals raised for meat or other product production, e.g. pigs, cattle or sheep, will be advantageous. Porcine submucosa provides a particularly preferred material for use in the present invention, especially porcine small intestine submucosa (SIS), more especially porcine small intestine submucosa retaining substantially its native cross-linking.

20

The submucosa or other ECM material can be derived from any suitable organ or other biological structure, including for example submucosa derived from the alimentary, respiratory, intestinal, urinary or genital tracts of warm-blooded vertebrates. Collagenous matrices comprising submucosa (potentially along with other associated tissues) useful in the present invention can be obtained by harvesting such tissue sources and delaminating the submucosa-containing matrix from smooth muscle layers, mucosal layers, and/or other layers occurring in the tissue source. For additional information concerning submucosa useful in certain embodiments of the present invention, and its isolation and treatment, reference can be made, for example, to U.S. Patent Nos. 4,902,508, 5,554,389, 5,993,844, 6,206,931, and 6,099,567.

30

Submucosa-containing or other ECM materials of the present invention can be derived from any suitable organ or other tissue source, usually sources containing connective tissues. The ECM materials processed for use in the invention will typically include abundant collagen, most commonly being constituted at least about 5 80% by weight collagen on a dry weight basis. Such naturally-derived ECM materials will for the most part include collagen fibers that are non-randomly oriented, for instance occurring as generally uniaxial or multi-axial but regularly oriented fibers. When processed to retain native bioactive factors, the ECM material can retain these factors interspersed as solids between, upon and/or within the 10 collagen fibers. Particularly desirable naturally-derived ECM materials for use in the invention will include significant amounts of such interspersed, non-collagenous solids that are readily ascertainable under light microscopic examination. Such non-collagenous solids can constitute a significant percentage of the dry weight of the ECM material in certain inventive embodiments, for example at least about 1%, at 15 least about 3%, and at least about 5% by weight in various embodiments of the invention.

The submucosa or other ECM material used in the present invention may also exhibit an angiogenic character and thus be effective to induce angiogenesis in a host engrafted with the material. In this regard, angiogenesis is the process through which 20 the body makes new blood vessels to generate increased blood supply to tissues. Thus, angiogenic materials, when contacted with host tissues, promote or encourage the formation of new blood vessels. Methods for measuring in vivo angiogenesis in response to biomaterial implantation have recently been developed. For example, one such method uses a subcutaneous implant model to determine the angiogenic 25 character of a material. See, C. Heeschen et al., *Nature Medicine* 7 (2001), No. 7, 833-839. When combined with a fluorescence microangiography technique, this model can provide both quantitative and qualitative measures of angiogenesis into biomaterials. C. Johnson et al., *Circulation Research* 94 (2004), No. 2, 262-268.

As prepared and used, the submucosa material or any other ECM material may optionally retain and/or otherwise include growth factors or other bioactive components native to the source tissue. For example, the submucosa or other ECM material may retain one or more growth factors such as basic fibroblast growth factor (FGF-2), transforming growth factor beta (TGF-beta), epidermal growth factor (EGF), cartilage derived growth factor (CDGF) and/or platelet derived growth factor (PDGF). As well, submucosa or other ECM material used in certain embodiments of the invention may retain or include other biological materials such as but not limited to proteins, glycoproteins, proteoglycans, and glycosaminoglycans. For example, ECM materials may include heparin, heparin sulfate, hyaluronic acid, fibronectin, cytokines and the like. Thus, generally speaking, the submucosa or other ECM material may retain or otherwise include a bioactive component that induces, directly or indirectly, a cellular response such as a change in cell morphology, proliferation, growth, protein or gene expression.

15

Further, in addition or as an alternative to the inclusion of such native bioactive components, non-native bioactive components such as those synthetically produced by recombinant technology or other methods, may be incorporated into the submucosa or other ECM material. These non-native bioactive components may be naturally-derived or recombinantly produced proteins that correspond to those natively occurring in the ECM material, but perhaps of a different species (e.g. human proteins applied to collagenous ECMs from other animals, such as pigs). The non-native bioactive components may also be drug substances. Illustrative drug substances that may be incorporated into and/or onto the ECM material can include, for example, antibiotics and/or thrombus-promoting substances such as blood clotting factors, e.g. thrombin, fibrinogen, and the like. These substances may be applied to the ECM material as a premanufactured step, immediately prior to the procedure (e.g. by soaking the material in a solution containing a suitable antibiotic such as cefazolin), or during or after engraftment of the ECM material within the patient.

30

Medical graft products of the invention can include xenograft material (i.e., cross-species material, such as tissue material from a non-human donor to a human recipient), allograft material (i.e., interspecies material, with tissue material from a donor of the same species as the recipient), and/or autograft material (i.e., where the donor and the recipient are the same individual). Further, any exogenous bioactive substance incorporated into an ECM material may be from the same species of animal from which the ECM material was derived (e.g. autologous or allogenic relative to the ECM material) or may be from a different species from the ECM material source (xenogenic relative to the ECM material). In certain embodiments, ECM material will be xenogenic relative to the patient receiving the graft, and any added exogenous material(s) will be from the same species (e.g. autologous or allogenic) as the patient receiving the graft. Illustratively, human patients may be treated with xenogenic ECM materials (e.g. porcine-, bovine- or ovine-derived) that have been modified with exogenous human material(s) as described herein, those exogenous materials being naturally derived and/or recombinantly produced.

Submucosa or other ECM material used in certain embodiments of the invention is preferably highly purified, for example, as described in U.S. Patent No. 6,206,931 to Cook et al. Thus, preferred ECM material will exhibit an endotoxin level of less than about 12 endotoxin units (EU) per gram, more preferably less than about 5 EU per gram, and most preferably less than about 1 EU per gram. As additional preferences, the submucosa or other ECM material may have a bioburden of less than about 1 colony forming units (CFU) per gram, more preferably less than about 0.5 CFU per gram. Fungus levels are desirably similarly low, for example less than about 1 CFU per gram, more preferably less than about 0.5 CFU per gram. Nucleic acid levels are preferably less than about 5 $\mu\text{g}/\text{mg}$, more preferably less than about 2 $\mu\text{g}/\text{mg}$, and virus levels are preferably less than about 50 plaque forming units (PFU) per gram, more preferably less than about 5 PFU per gram. The ECM material used in certain embodiments of the invention is preferably disinfected with an oxidizing agent, particularly a peracid, such as peracetic acid. These and additional

properties of submucosa or other ECM materials taught in U.S. Patent No. 6,206,931 may be characteristic of the submucosa used in certain embodiments of the present invention.

5 A typical layer thickness for an as-isolated submucosa or other ECM tissue layer used in the invention ranges from about 50 to about 250 microns when fully hydrated, more typically from about 50 to about 200 microns when fully hydrated, although isolated layers having other thicknesses may also be obtained and used. These layer thicknesses may vary with the type and age of the animal used as the
10 tissue source. As well, these layer thicknesses may vary with the source of the tissue obtained from the animal source.

ECM materials used in the invention may be free or essentially free of additional, non-native crosslinking, or may contain additional crosslinking. Such
15 additional crosslinking may be achieved by photo-crosslinking techniques, by chemical crosslinkers, or by protein crosslinking induced by dehydration or other means. However, because certain crosslinking techniques, certain crosslinking agents, and/or certain degrees of crosslinking can destroy the remodelable properties of a remodelable material, where preservation of remodelable properties is desired,
20 any crosslinking of the remodelable ECM material can be performed to an extent or in a fashion that allows the material to retain at least a portion of its remodelable properties. Chemical crosslinkers that may be used include for example aldehydes such as glutaraldehydes, diimides such as carbodiimides, e.g., 1-ethyl-3-(3-
25 dimethylaminopropyl)carbodiimide hydrochloride, ribose or other sugars, acyl-azide, sulfo-N-hydroxysuccinamide, or polyepoxide compounds, including for example polyglycidyl ethers such as ethyleneglycol diglycidyl ether, available under the trade name DENACOL EX810 from Nagese Chemical Co., Osaka, Japan, and glycerol polyglycerol ether available under the trade name DENACOL EX 313 also from Nagese Chemical Co. Typically, when used, polyglycerol ethers or other polyepoxide
30 compounds will have from 2 to about 10 epoxide groups per molecule.

Turning now to a discussion of drying techniques that can be useful in certain embodiments of the invention, drying by evaporation, or air drying, generally comprises drying a partially or completely hydrated remodelable material by allowing the hydrant to evaporate from the material. Evaporative cooling can be enhanced in a number of ways, such as by placing the material in a vacuum, by blowing air over the material, by increasing the temperature of the material, by applying a blotting material during evaporation, or by any other suitable means or any suitable combination thereof. The amount of void space or open matrix structure within an ECM material that has been dried by evaporation is typically more diminished than, for example, an ECM material dried by lyophilization as described below.

A suitable lyophilization process can include providing an ECM material that contains a sufficient amount of hydrant such that the voids in the material matrix are filled with the hydrant. The hydrant can comprise any suitable hydrant known in the art, such as purified water or sterile saline, or any suitable combination thereof. Illustratively, the hydrated material can be placed in a freezer until the material and hydrant are substantially in a frozen or solid state. Thereafter, the frozen material and hydrant can be placed in a vacuum chamber and a vacuum initiated. Once at a sufficient vacuum, as is known in the art, the frozen hydrant will sublime from the material, thereby resulting in a dry remodelable material.

In alternative embodiments, a hydrated ECM material can be lyophilized without a separately performed pre-freezing step. In these embodiments, a strong vacuum can be applied to the hydrated material to result in rapid evaporative cooling which freezes the hydrant within the ECM material. Thereafter, the frozen hydrant can sublime from the material thereby drying the ECM material. Desirably, an ECM material that is dried via lyophilization maintains a substantial amount of the void space, or open matrix structure, that is characteristic of the harvested ECM material.

Drying by vacuum pressing generally comprises compressing a fully or partially hydrated remodelable material while the material is subject to a vacuum. One suitable method of vacuum pressing comprises placing a remodelable material in a vacuum chamber having collapsible walls. As the vacuum is established, the walls collapse onto and compress the material until it is dry. Similar to evaporative drying, when a remodelable material is dried in a vacuum press, more of the material's open matrix structure is diminished or reduced than if the material was dried by lyophilization.

In certain aspects, the invention provides medical products including a multilaminate material. Such multilaminate materials can include a plurality of ECM material layers bonded together, a plurality of non-ECM materials bonded together, or a combination of one or more ECM material layers and one or more non-ECM material layers bonded together. To form a multilaminate ECM material, for example, two or more ECM segments are stacked, or one ECM segment is folded over itself at least one time, and then the layers are fused or bonded together using a bonding technique, such as chemical cross-linking or vacuum pressing during dehydrating conditions. An adhesive, glue or other bonding agent may also be used in achieving a bond between material layers. Suitable bonding agents may include, for example, collagen gels or pastes, gelatin, or other agents including reactive monomers or polymers, for example cyanoacrylate adhesives. As well, bonding can be achieved or facilitated between ECM material layers using chemical cross-linking agents such as those described above. A combination of one or more of these with dehydration-induced bonding may also be used to bond ECM material layers to one another.

A variety of dehydration-induced bonding methods can be used to fuse together portions of an ECM material. In one preferred embodiment, multiple layers of ECM material are compressed under dehydrating conditions. In this context, the term "dehydrating conditions" is defined to include any mechanical or environmental condition which promotes or induces the removal of water from the ECM material.

To promote dehydration of the compressed ECM material, at least one of the two surfaces compressing the matrix structure can be water permeable. Dehydration of the ECM material can optionally be further enhanced by applying blotting material, heating the matrix structure or blowing air, or other inert gas, across the exterior of the compressed surfaces. One particularly useful method of dehydration bonding ECM materials is lyophilization.

Another method of dehydration bonding comprises pulling a vacuum on the assembly while simultaneously employing the vacuum to press the assembly together. Again, this method is known as vacuum pressing. During vacuum pressing, dehydration of the ECM materials in forced contact with one another effectively bonds the materials to one another, even in the absence of other agents for achieving a bond, although such agents can be used while also taking advantage at least in part of the dehydration-induced bonding. With sufficient compression and dehydration, the ECM materials can be caused to form a generally unitary ECM structure.

It is advantageous in some aspects of the invention to perform drying and other operations under relatively mild temperature exposure conditions that minimize deleterious effects upon any ECM materials being used, for example native collagen structures and potentially bioactive substances present. Thus, drying operations conducted with no or substantially no duration of exposure to temperatures above human body temperature or slightly higher, say, no higher than about 38° C, will preferably be used in some forms of the present invention. These include, for example, vacuum pressing operations at less than about 38° C, forced air drying at less than about 38° C, or either of these processes with no active heating – at about room temperature (about 25° C) or with cooling. Relatively low temperature conditions also, of course, include lyophilization conditions.

In additional embodiments, medical graft products of the invention can be made from ECM's or other collagenous materials that have been subjected to

processes that expand the materials. In certain forms, such expanded materials can be formed by the controlled contact of an ECM material with one or more alkaline substances until the material expands, and the isolation of the expanded material. Illustratively, the contacting can be sufficient to expand the ECM material to at least 5 120% of (i.e. 1.2 times) its original bulk volume, or in some forms to at least about two times its original volume. Thereafter, the expanded material can optionally be isolated from the alkaline medium, e.g. by neutralization and/or rinsing. The collected, expanded material can be used in any suitable manner in the preparation of a graft device. Illustratively, the expanded material can be enriched with bioactive 10 components, dried, and/or molded, etc., in the formation of a graft construct to a desired shape or configuration. In certain embodiments, a dried graft construct formed with the expanded ECM material can be highly compressible (or expandable) such that the material can be compressed for delivery, such as from within the lumen of a cannulated delivery device, and thereafter expand upon deployment from the 15 device so as to become anchored within a patient and/or cause closure of a tract within the patient.

Expanded collagenous or ECM materials can be formed by the controlled contact of a collagenous or ECM material with an aqueous solution or other medium 20 containing sodium hydroxide. Alkaline treatment of the material can cause changes in the physical structure of the material that in turn cause it to expand. Such changes may include denaturation of the collagen in the material. In certain embodiments, it is preferred to expand the material to at least about three, at least about four, at least about 5, or at least about 6 or even more times its original bulk volume. The 25 magnitude of the expansion is related to several factors, including for instance the concentration or pH of the alkaline medium, exposure time, and temperature used in the treatment of the material to be expanded.

ECM materials that can be processed to make expanded materials can include 30 any of those disclosed herein or other suitable ECM's. Typical such ECM materials

will include a network of collagen fibrils having naturally-occurring intramolecular cross links and naturally-occurring intermolecular cross links. Upon expansion processing as described herein, the naturally-occurring intramolecular cross links and naturally-occurring intermolecular cross links can be retained in the processed collagenous matrix material sufficiently to maintain the collagenous matrix material as an intact collagenous sheet material; however, collagen fibrils in the collagenous sheet material can be denatured, and the collagenous sheet material can have an alkaline-processed thickness that is greater than the thickness of the starting material, for example at least 120% of the original thickness, or at least twice the original thickness.

Illustratively, the concentration of the alkaline substance for treatment of the remodelable material can be in the range of about 0.5 to about 2 M, with a concentration of about 1 M being more preferable. Additionally, the pH of the alkaline substance can in certain embodiments range from about 8 to about 14. In preferred aspects, the alkaline substance will have a pH of from about 10 to about 14, and most preferably of from about 12 to about 14.

In addition to concentration and pH, other factors such as temperature and exposure time will contribute to the extent of expansion, as discussed above. In this respect, in certain variants, the exposure of the collagenous material to the alkaline substance is performed at a temperature of about 4 to about 45 °C. In preferred embodiments, the exposure is performed at a temperature of about 25 to about 40 °C, with 37 °C being most preferred. Moreover, the exposure time can range from at least about one minute up to about 5 hours or more. In some embodiments, the exposure time is about 1 to about 2 hours. In a particularly preferred embodiment, the collagenous material is exposed to a 1 M solution of NaOH having a pH of 14 at a temperature of about 37 °C for about 1.5 to 2 hours. Such treatment results in collagen denaturation and a substantial expansion of the remodelable material. Denaturation of the collagen matrix of the material can be observed as a change in the

collagen packing characteristics of the material, for example a substantial disruption of a tightly bound collagenous network of the starting material. A non-expanded ECM or other collagenous material can have a tightly bound collagenous network presenting a substantially uniform, continuous surface when viewed by the naked eye or under moderate magnification, e.g. 100x magnification. Conversely, an expanded collagenous material can have a surface that is quite different, in that the surface is not continuous but rather presents collagen strands or bundles in many regions that are separated by substantial gaps in material between the strands or bundles when viewed under the same magnification, e.g. about 100x. Consequently, an expanded collagenous material typically appears more porous than a corresponding non-expanded collagenous material. Moreover, in many instances, the expanded collagenous material can be demonstrated as having increased porosity, e.g. by measuring for an increased permeability to water or other fluid passage as compared to the non-treated starting material. The more foamy and porous structure of an expanded ECM or other collagenous material can allow the material to be cast or otherwise prepared into a variety of sponge or foam shapes for use in the preparation of medical materials and devices. It can further allow for the preparation of constructs that are highly compressible and which expand after compression. Such properties can be useful, for example, when the prepared graft construct is to be compressed and loaded into a deployment device (e.g. a lumen thereof) for delivery into a patient, and thereafter deployed to expand at the implant site.

After such alkaline treatments, the material can be isolated from the alkaline medium and processed for further use. Illustratively, the collected material can be neutralized and/or rinsed with water to remove the alkalinity from the material, prior to further processing of the material to form a graft construct.

A starting ECM material (i.e., prior to treatment with the alkaline substance) can optionally include a variety of bioactive or other non-collagenous components including, for example, growth factors, glycoproteins, glycosaminoglycans,

proteoglycans, nucleic acids, and lipids. Treating the material with an alkaline substance may reduce the quantity of one, some or all of such non-collagenous components contained within the material. In certain embodiments, controlled treatment of the remodelable material with an alkaline substance will be sufficient to
5 create a remodelable collagenous material which is substantially devoid of nucleic acids and lipids, and potentially also of growth factors, glycoproteins, glycosaminoglycans, and proteoglycans.

In certain embodiments, one or more bioactive components, exogenous or
10 endogenous, for example, similar to those removed from an expanded material during alkaline processing, can be returned to the material. For example, an expanded material can include a collagenous material which has been depleted of nucleic acids and lipids, but which has been replenished with growth factors, glycoproteins, glycosaminoglycans, and/or proteoglycans. These bioactive components can be
15 returned to the material by any suitable method. For instance, in certain forms a tissue extract, such as is discussed in U.S. Patent No. 6,375,989 which is hereby incorporated herein by reference in its entirety, containing these components can be prepared and applied to an expanded collagenous material. In one embodiment, the expanded collagenous material can be incubated in a tissue extract for a sufficient
20 time to allow bioactive components contained therein to associate with the expanded collagenous material. The tissue extract may, for example, be obtained from non-expanded collagenous tissue of the same type used to prepare the expanded material. Other means for returning or introducing bioactive components to an expanded remodelable collagenous material include spraying, impregnating, dipping, etc. as
25 known in the art. By way of example, an expanded collagenous material may be modified by the addition of one or more growth factors such as basic fibroblast growth factor (FGF-2), transforming growth factor beta (TGF beta), epidermal growth factor (EGF), platelet derived growth factor (PDGF), and/or cartilage derived growth factor (CDGF). As well, other biological components may be added to an expanded
30 collagenous material, such as heparin, heparin sulfate, hyaluronic acid, fibronectin

and the like. Thus, generally speaking, an expanded collagenous material may include a bioactive component that induces, directly or indirectly, a cellular response such as a change in cell morphology, proliferation, growth, protein or gene expression similar to a non-expanded collagenous material.

5

Expanded collagenous materials can be used to prepare a wide variety of fistula plug devices. Methods for preparing such plug devices can include contacting an ECM or other collagenous starting material with an alkaline substance in an amount effective to expand the material, casting or otherwise forming the expanded collagenous material into a plug shape (e.g. one of those described herein), and lyophilizing the expanded material to form a dried plug device.

10

Medical graft products of the invention may include biocompatible materials derived from a number of biological polymers, which can be naturally occurring or the product of in vitro fermentation, recombinant genetic engineering, and the like. Purified biological polymers can be appropriately formed into a substrate by techniques such as weaving, knitting, casting, molding, and extrusion. Suitable biological polymers include, without limitation, collagen, elastin, keratin, gelatin, polyamino acids, polysaccharides (e.g., cellulose and starch) and copolymers thereof.

15

20

Suitable biocompatible medical products of the invention can also include a variety of synthetic polymeric materials including but not limited to bioresorbable and/or non-bioresorbable plastics. Bioresorbable, or bioabsorbable polymers that may be used include, but are not limited to, poly(L-lactic acid), polycaprolactone, poly(lactide-co-glycolide), poly(hydroxybutyrate), poly(hydroxybutyrate-co-valerate), polydioxanone, polyorthoester, poly(anhydride), poly(glycolic acid), poly(D,L-lactic acid), poly(glycolic acid-co-trimethylene carbonate), polyhydroxyalkanoates, polyphosphoester, polyphosphoester urethane, poly(amino acids), cyanoacrylates, poly(trimethylene carbonate), poly(iminocarbonate), copoly(ether-esters) (e.g., PEO/PLA), polyalkylene oxalates, and polyphosphazenes. These or other

25

30

bioresorbable materials may be used, for example, where only a temporary blocking or closure function is desired, and/or in combination with non-bioresorbable materials where only a temporary participation by the bioresorbable material is desired.

5 Non-bioresorbable, or biostable polymers that may be used include, but are not limited to, polytetrafluoroethylene (PTFE) (including expanded PTFE), polyethylene terephthalate (PET), polyurethanes, silicones, and polyesters and other polymers such as, but not limited to, polyolefins, polyisobutylene and ethylene-alphaolefin copolymers; acrylic polymers and copolymers, vinyl halide polymers and
10 copolymers, such as polyvinyl chloride; polyvinyl ethers, such as polyvinyl methyl ether; polyvinylidene halides, such as polyvinylidene fluoride and polyvinylidene chloride; polyacrylonitrile, polyvinyl ketones; polyvinyl aromatics, such as polystyrene, polyvinyl esters, such as polyvinyl acetate; copolymers of vinyl monomers with each other and olefins, such as ethylene-methyl methacrylate
15 copolymers, acrylonitrile-styrene copolymers, ABS resins, and ethylene-vinyl acetate copolymers; polyamides, such as Nylon 66 and polycaprolactam; alkyd resins, polycarbonates; polyoxymethylenes; polyimides; polyethers; epoxy resins, polyurethanes; rayon; and rayon-triacetate. For further information concerning suitable synthetic materials (both biodegradable and nonbiodegradable), useful in
20 certain embodiments of the present invention, reference can be made, for example, to U.S. Utility Patent Application Pub. No. 2005/0228486 titled, "Implantable Frame with Variable Compliance," filed on April 11, 2005 ("Express Mail" Mailing Label No. EV 327 135 804 US), which claims priority to U.S. Provisional Patent Application titled, "Implantable Frame with Variable Compliance," filed on April 13,
25 2004. Such synthetic materials can be used to form fistula plug devices as described herein, either alone or in combination with ECM or other collagenous materials herein identified.

Turning now to a discussion of particular medical graft products, systems, and
30 methods of the present invention useful for treating fistulae, illustrative medical graft

products of the invention are configured to block at least the primary opening of a fistula, i.e., the primary opening and potentially one or more other segments of a fistula, for example, the fistula tract and/or any secondary openings. In this context, the term “fistula tract” is meant to include, but is not limited to, a void in soft tissues extending from a primary fistula opening, whether blind-ending or leading to one or more secondary fistula openings, for example, to include what are generally described as simple and complex fistulae. Fistula grafts of the invention include a biocompatible graft body including a capping member and an elongate plug member extending from the capping member. The capping member is configured to contact portions of the alimentary canal wall adjacent to the primary opening, and the elongate plug member is configured to extend into at least a portion of the fistula tract. In performing these functions, the capping member and the elongate plug member can exhibit any suitable size and shape and can include any suitable device and/or material, as long as the graft body is able to block at least the primary opening of a fistula.

In some embodiments, the present invention provides fistula graft products that are useful in treating gastrointestinal fistulae. Illustratively, these products can be configured to block at least a fistula opening occurring in an alimentary canal wall, and particularly those occurring in the stomach and intestine. In advantageous embodiments, these products will at least include a capping member and an elongate plug member extending from the capping member, wherein the capping member is configured to contact portions of the alimentary canal wall adjacent to the fistula opening, and the elongate plug member is configured to extend into, and in some cases fill, at least a portion of a gastrointestinal fistula tract. While these products are particularly suited for treating gastrointestinal fistulae, it will be understood that such products may be useful in treating other types of fistulae as well, and in some forms, are useful in filling, blocking or otherwise treating non-fistula openings or passages occurring in the body.

Any capping member present in an inventive product may be constructed along with the elongate plug member to provide a single unitary construct, for example, a single-capped device formed from a single piece of material or other substance. In some embodiments, a particular capping member may be formed
5 separately from and an elongate plug member and then subsequently combined or otherwise retained in association with the plug member, for example, by suturing the two together, applying an adhesive, using mechanical fastener(s), or employing any other suitable means or combination thereof. In one embodiment, an inventive medical graft product comprises an elongate plug member and a capping member,
10 wherein the capping member is formed separately from the plug member and is hingedly coupled to an end of the plug member, e.g., before or during an implantation procedure. In certain aspects, a capping member and an elongate plug member are formed from separate pieces of material, yet are retained in association with one another without the use of another device or material (e.g., sutures, an adhesive, etc.).
15 In such aspects, the elongate plug member and one or more capping members are joined together by having at least one member (or any portion thereof) received around, through, over, etc., at least one other member (or any portion thereof).

In some forms, one or more capping members are each formed separately
20 from an elongate plug member, and then coupled to the plug member with an absorbable device or material. These coupling elements can exhibit any suitable size, shape, and configuration, and in some embodiments, take the form of an adhesive or one or more hooks, fasteners, barbs, straps, suture strands, or combinations thereof. Additionally, such devices and materials can be configured to degrade at varying rates
25 upon being implanted in vivo. In one embodiment, 2-0 vicryl suture material is used to join one or more capping members to an elongate plug member. Illustratively, a coupling element can be adapted to desirably hold one or more capping members in association with a plug member during product handling and implantation, and then upon implantation, to degrade at a desirable rate. In some modes of operation, a
30 capping member and an elongate plug member, at least due in part to degradation of

the coupling element, can uncouple or otherwise disengage from one another after a period of time following implantation, allowing the capping member to pass through and out of the body naturally.

5 In certain embodiments, the capping member can be hingedly coupled to the elongate plug member. By “hingedly coupled” is meant that the capping member is not rigidly fixed to the elongate body member and can therefore tilt or swing relative to the elongate body member while still being coupled to it. For example, prior to loading the medical graft product into a deployment device such as a sheath (e.g.,
10 Flexor® sheath available from Cook Urological, Inc., 1100 West Morgan Street, P.O. Box 227 Spencer, Indiana 47460) the capping member can be tilted a distance toward an opposing end (i.e., from the distal end towards the proximal end or vice versa) of the elongate body member and rolled over the elongate body member so as to allow for the medical graft product to be positioned into a deployment device. In this
15 respect, the capping member has an implantable configuration wherein the opposite sides of the member are brought in closer proximity to one another so as to be able to fit within the lumen of a delivery device, such as a catheter or sheath. In certain aspects, the distal end of the deployment device can be inserted into a fistula, for example, into a secondary opening, through a fistula tract, and a distance out of the
20 primary opening. Thereafter, the graft body (or at least the capping member) can be delivered from the deployment device, allowing the capping member to expand. Then, the graft body can be pulled back through the fistula tract until the capping member contacts portions of the alimentary canal wall adjacent to the primary opening. The delivery device can then be withdrawn from the fistula through the
25 secondary opening while maintaining the position of the graft body with a pusher rod or any other suitable means, leaving the graft deployed within the fistula and blocking at least the primary fistula opening.

 The capping member is configured to contact portions of the alimentary canal
30 wall adjacent to the primary opening. The capping member may include a frame

comprising a single piece of superelastic wire or other material having a plurality of sides and bends interconnecting adjacent sides. The bends can be coils, fillets, or other configurations to reduce stress and fatigue. The single piece of wire is preferably joined by an attachment mechanism, such as a piece of cannula and solder,
5 to form a closed circumference frame.

The frame can comprise a metallic material including but not limited to stainless steel, titanium, cobalt, tantalum, gold, platinum, nickel, iron, copper and the like, as well as alloys of these metals (e.g., cobalt alloys, such as Elgiloy®, a cobalt-
10 chromium-nickel alloy, MP35N, a nickel-cobalt-chromium-molybdenum alloy, and Nitinol®, a nickel-titanium alloy). Additionally or alternatively, suitable frames can include material in the form of yarns, fibers, and/or resins, e.g., monofilament yarns, high tenacity polyester, and the like. A frame element can also include other plastic, resin, polymer, woven, and fabric surgical materials, other conventional synthetic
15 surgical materials, such as a shape-memory plastic, and/or combinations of such materials. Further, appropriate ceramics can be used, including, without limitation, hydroxyapatite, alumina and pyrolytic carbon. Such metallic and other materials may be used in forming other expandable and non-expandable graft body components useful in the present invention. A capping member can also include a flexible
20 material covering extending between sides of the frame. Such a covering can be formed with any suitable material such as but not limited to DACRON®, THORALON®, PTFE, collagen, submucosa, or other flexible material, and can be attached to the frame with sutures or other suitable attachment means.

25 The capping member can be comprised of a frame in the form of a tulip filter. The capping member may also include a flexible material covering attached to the tulip filter frame. Such a covering can be formed with any suitable material such as but not limited to DACRON, PTFE, collagen, submucosa, or other flexible material, and can be attached to the tulip filter with sutures or other suitable means. In certain
30 other aspects, such a covering is not included as part of the capping member.

The components of an inventive graft construct (e.g., an elongate plug member and a capping member), whether formed separately or together as a single unit, can be constructed in any suitable manner, for example, using any of the processes described
5 herein. In some embodiments, an elongate plug member and a capping member are formed with a reconstituted or otherwise processed ECM material. Elongate plug members and capping members can also be formed by folding or rolling, or otherwise overlaying one or more portions of a biocompatible material, such as a biocompatible sheet material. The overlaid biocompatible sheet material can be compressed and
10 dried or otherwise bonded into a volumetric shape such that a substantially unitary construct is formed. In some forms, an inventive graft component such as the elongate graft body is constructed by randomly or regularly packing one or more pieces of single or multilayer ECM sheet material within a mold and thereafter processing the packed material. Elongate plug members useful in the invention can
15 be prepared, for example, as described in International Patent Application Serial No. PCT/US2006/16748, filed April 29, 2006, and entitled "VOLUMETRIC GRAFTS FOR TREATMENT OF FISTULAE AND RELATED METHODS AND SYSTEMS" (Cook Biotech Incorporated), which is hereby incorporated by reference in its entirety.

20

When formed separately, a capping member may or may not be comprised of the same biocompatible material(s) as the elongate plug member (or, if present, another capping member). In certain aspects, the elongate plug member and/or any capping member present are comprised of a remodelable material, and in some cases a
25 remodelable collagenous material. Illustratively, a capping member and an elongate plug member can be formed from separate pieces of remodelable, collagenous material (e.g., remodelable SIS material), and thereafter coupled to one another in accordance with the present invention. In certain embodiments, the elongate plug member can be formed of lyophilized ECM material, and the capping member can be
30 formed of a stiffer ECM material, such as an air-dried or vacuum pressed ECM

material. In advantageous embodiments, the capping member can be formed of a vacuum pressed, multi-laminate ECM construct, for example having from about two to about ten ECM layers bonded to one another.

5 As well, inventive graft products and their components can exhibit any suitable size and shape for treating gastrointestinal fistulae and other bodily openings and passageways. An elongate plug member may either have a constant or varying cross-sectional area along its length. For example, elongate plug members useful in the invention may exhibit a generally cylindrical shape, a conical shape, a shape
10 having tapered and non-tapered longitudinal portions, or other suitable shapes having rectilinear and/or curvilinear portions. Also, as discussed in more detail below, some elongate graft bodies of the invention can have one or more lumens extending at least partially through the bodies along their length. A capping member can include one or more objects (e.g., pieces of material) that, together or alone, exhibit a three-
15 dimensional rectilinear or curvilinear shape. Suitable three-dimensional rectilinear shapes can have any suitable number of sides, and can include, for example, cubes, cuboids, tetrahedrons, prisms, pyramids, wedges, and variations thereof. Suitable three-dimensional curvilinear bodies can include, for example, spheres, spheroids, ellipsoids, cylinders, cones, and any suitable variations thereof (e.g., a segment of a
20 sphere, or a truncated cone, etc.). Capping members useful in the invention can be prepared, for example, as described in International Patent Application Serial No. PCT/US2007/061371, filed January 31, 2007, and entitled "FISTULA GRAFTS AND RELATED METHODS AND SYSTEMS FOR TREATING FISTULAE" (Cook Biotech Incorporated), which is hereby incorporated by reference in its entirety.

25

 Illustrative elongate plug members of the invention will be of sufficient size and shape to extend into at least a portion of a fistula tract, and will generally (but not necessarily) be of sufficient dimension to fill a fistula, or a segment thereof, e.g., the primary fistula opening, a fistula tract, and/or any secondary fistula openings, either
30 alone or in combination with other similar or differing devices. In certain

embodiments, the elongate plug member will have a length of at least about 0.20 cm, and in many situations at least about 1 cm to about 20 cm (approximately 1 to 8 inches). In illustrative embodiments, the plug member will have a length of from about 2 cm to about 5 cm, or alternatively, from about 2 inches to about 4 inches.

5 Additionally, in certain embodiments, elongate plug members will have a diameter, which may or may not be constant along their length, of from about 0.1 mm to about 25 mm, or more typically from about 5 mm to about 10 mm. In certain embodiments, a generally conical plug member is tapered along its length so that the end of the plug member proximate the capping member has a diameter of about 5 mm to about 10

10 mm and the opposite end of the plug member has a diameter of about 0.5 mm to about 3 mm. Such a taper may or may not be continuous along the length of the elongate plug member.

The elongate plug member may comprise a compliant sheet form

15 biocompatible material comprising two or more layers of ECM material bonded together. This sheet form elongate plug member can be coupled to or otherwise joined with any of the capping members described herein, for example, the capping member of Figure 1. This sheet form plug member can be prepared, for example, as described in International Patent Application Serial No. PCT/US2006/16233, filed

20 April 29, 2006, and entitled "FISTULA GRAFT WITH DEFORMABLE SHEET-FORM MATERIAL" (Cook Biotech Incorporated), which is hereby incorporated by reference in its entirety.

The sheet form material is deformable upon impingement by soft tissue

25 surrounding a fistula (e.g., tissue surrounding the primary fistula opening, the fistula tract, and/or any secondary fistula openings) and/or upon impingement by walls of the lumen of a delivery device. Such deformable materials can include any of the ECM or other biocompatible materials described herein, for example, a multilaminate sheet of remodelable SIS material. Further, the sheet form plug is sized and shaped so as to

30 be deformable to a three-dimensional volumetric body extending into at least a

portion of the fistula tract, and potentially filling at least a portion of the fistula tract, the primary opening, and/or any secondary openings of the fistula. In so doing, advantageous implant materials will also be sufficiently flaccid to avoid substantial cutting or tearing of the surrounding soft tissues.

5

In certain aspects, a sheet form graft body is shaped and sized such that the diameter of the primary opening is less than the width of the sheet so that the sheet of material as deployed in the fistula tract is folded and/or rolled over itself one or more times to conform to soft tissues surrounding the fistula and lodge within the fistula tract. Such lodging in place may be sufficient to obviate the need for otherwise securing the graft to the soft tissues at or near the primary opening, fistula tract, and/or any secondary openings. Nonetheless, in certain aspects, the graft is further secured to such soft tissues, for example, by suturing.

15 Inventive graft body formation methods can involve manipulating graft material within a mold or form. It should be noted that the graft material may or may not be hydrated when placed in, on, around, etc. a mold or form. In some methods, a substantially dry ECM material (e.g., a powder or sheet material) can be placed in a mold and then suitably hydrated for further processing. In other methods, a hydrated starting material is placed in and/or on a mold or forming structure for further processing. For example, one or more hydrated sheets of ECM material can be applied to a form, e.g., wrapped at least partially around a mandrel so that portions of the sheet(s) overlap. Then, the one or more sheets can be dried, and in some embodiments, dried while under compression, to form a unitary graft construct. In some modes of operation, a hydrated graft material is provided within a single- or multiple-part mold having a plurality of apertures or holes extending through a wall of the mold, thereby providing access to the mold interior from an external location. These apertures can serve to enhance drying of a hydrated material during a processing step and in processes exerting vacuum pressure at these apertures, can promote and/or facilitate formation of surface protuberances on the graft material as

30

portions of the same are drawn toward the apertures while under vacuum. In one aspect, an amount of ECM material is retained in such a mold, and needles or other material-displacing objects are inserted through some or all of the mold apertures and a distance into the ECM material, thereby displacing volumes of the ECM material.

5 This can be performed when the graft material is hydrated, partially hydrated or dehydrated. In some forms, with needles inserted in a hydrated ECM material and providing passages therein, the material is subjected to conditions (e.g., freezing and/or dehydrating conditions) which, alone or in combination with one or more other conditions, cause or allow the passages to be generally retained in the ECM material

10 after the needles are removed.

In one embodiment, one or more sheets of hydrated ECM material are suitably wrapped and/or randomly packed around a mandrel, and then a mold having a plurality of holes extending through a wall of the mold is placed around the material-

15 covered mandrel, for example, so that an amount of pressure is placed on the ECM material. The mandrel can then optionally be removed. Thereafter, needles or other material-displacing objects are inserted through some or all of the holes and at least partially through the ECM material, thereby displacing volumes of the ECM material. The ECM material is then at least partially dried. In some aspects, a suitable

20 lyophilization technique is employed, e.g., one with or without a pre-freezing step as described herein. In these or other drying methods in which needles or other penetrating elements are to be left within the mass during drying, these elements can optionally be provided with a plurality of apertures or holes or can otherwise be sufficiently porous to facilitate the drying operation by allowing the passage of

25 hydrate from the wet mass. In one embodiment, a hydrated ECM material with emplaced needles can be subjected to freezing conditions so that the material and any contained hydrate become substantially frozen. Thereafter, the needles can be removed from the ECM material, and the remaining construct (with the frozen material passages substantially retaining their shape) can be placed under a vacuum so

that the frozen hydrant sublimates from the material, thereby resulting in a dry graft construct with retained passages therein.

5 In other modes of operation, passage-forming structures can be incorporated integrally into a mold so that passageways are formed upon introducing the starting material in and/or on the mold. In these aspects, the passage-forming structures can be part of the mold (e.g., extend from a surface of the mold), or they can be separate objects attached or otherwise coupled to the mold, to provide the desired passage or passages through the ultimately-formed graft body.

10

Although not necessary to broader aspects of the invention, in some aspects, the formation of such a graft construct comprises wrapping one or more sheets of hydrated graft material around a mandrel a number of times. The resulting roll of graft material is then introduced into a mold, and the mandrel is removed (optional), e.g., before or after applying the mold. Thereafter, multiple material-displacing objects such as but not limited to needles are forced through apertures in the mold and into the hydrated graft material, and the material is subjected to one or more drying techniques such as a lyophilization process. In other aspects, the formation of such a graft construct includes placing a flowable graft material into a mold and then

15 20 25

subjecting the graft material to further processing. For example, a flowable ECM material mass, such as a gel, paste or putty, potentially incorporating a particulate ECM material, can be placed into a mold, and then with volumes of material displaced in the mass (e.g., by penetrating needles), the ECM material can be dried or otherwise caused to form an integral piece to provide a graft body having passages therein. Illustratively, each of the passages can be provided by forcing a single object through the material mass, or alternatively, where a mandrel is left in place to form a longitudinal lumen, by forcing two objects into the mass and toward one another from opposite directions until they abut the mandrel. The mass can then be processed to a solid graft body as discussed herein.

30

When implanted in accordance with the present invention, and thus contacting portions of the alimentary canal wall adjacent to the primary opening, the capping member may or may not have a portion extending into the primary opening. For example, in some aspects, the graft body is configured so that no portion of the capping member resides within the primary opening when the graft body is implanted, while in other aspects, the graft body is configured so that a portion of the capping member *does* reside within the primary opening when the graft body is implanted. Also, it should again be noted that the graft body as a whole, i.e., the combination of the capping member and the elongate plug member, is configured to block at least the primary opening of a fistula. However, neither the capping member portion of the graft body nor the elongate plug member portion of the graft body need be configured to block the primary fistula opening independent of the other member, although either member may be so configured. Additionally, the capping member portion of the graft body, by itself, may or may not be configured to block the fistula tract. In this regard, blocking a particular space or void can be accomplished by filling that space with the capping member, or a portion thereof. In certain aspects, the capping member can be configured to fill the primary opening and/or a portion of the fistula tract. Such filling can, in some embodiments, seal off or substantially seal off the primary opening and/or a portion of the fistula tract.

20

When suitably implanted, and thus extending into at least a portion of the fistula tract, the elongate plug member may or may not have a portion extending into the primary opening. For example, in some aspects, the graft body is configured so that at least a portion of the elongate plug member resides within the fistula tract but no portion of the elongate plug member resides within the primary opening when the graft is implanted. In other aspects, the elongate plug member is configured to extend through the primary opening and into at least a portion of the fistula tract when the graft body is implanted. Again, in certain embodiments it is the graft body as a whole, i.e., the combination of the capping member and the elongate plug member, that is configured to block at least the primary opening of a fistula. Neither the

30

capping member portion of the graft body nor the elongate plug member portion of the graft body need be configured to block the primary opening independent of the other member, although either member may be so configured. Additionally, the elongate plug member portion of the graft body, by itself, may or may not be
5 configured to block the fistula tract. Further, the elongate plug member portion, by itself, may or may not be configured to block any secondary fistula opening. In this regard, blocking a particular space or void can be accomplished by filling that space with the elongate plug member, or a portion thereof. In certain aspects, the elongate plug member can be configured to fill the primary opening, the fistula tract (or any
10 portion thereof), and/or any secondary openings of the fistula. Such filling can, in some embodiments, seal off or substantially seal off the primary opening, the fistula tract (or any portion thereof), and/or any secondary opening of the fistula.

In certain aspects, the medical graft product comprises a material receptive to
15 tissue ingrowth. In such aspects, upon deployment of the product in accordance with the present invention, cells from the patient can infiltrate the material, leading to, for example, new tissue growth on, around, and/or within the medical graft product. In some embodiments, the medical graft product comprises a remodelable material. In these embodiments, the remodelable material promotes and/or facilitates the
20 formation of new tissue, and is capable of being broken down and replaced by new tissue in such a way that the original fistula closure achieved by the implanted graft product is maintained throughout the remodeling process so as to eventually form a closure or substantial closure with the new tissue.

25 Remodelable ECM materials having a relatively more open matrix structure (i.e., higher porosity) are capable of exhibiting different material properties than those having a relatively more closed or collapsed matrix structure. For example, an ECM material having a relatively more open matrix structure is generally softer and more readily compliant to an implant site than one having a relatively more closed matrix
30 structure. Also, the rate and amount of tissue growth in and/or around a remodelable

material can be influenced by a number of factors, including the amount of open space available in the material's matrix structure for the infusion and support of a patient's tissue-forming components, such as fibroblasts. Therefore, a more open matrix structure can provide for quicker, and potentially more, growth of patient
5 tissue in and/or around the remodelable material, which in turn, can lead to quicker remodeling of the material by patient tissue.

In this regard, any component of a medical graft product of the invention (including any ECM material) can have a level or degree of porosity. In certain
10 embodiments, the porosity of a layer of ECM material is lowered by drying the material under compression. In general, compressing a pliable open matrix material, such as a pliable ECM material, increases the material's bulk density and decreases the material's porosity by decreasing the size of the voids in the open matrix. As is the case in certain aspects of the invention, when such a material is dried while being
15 compressed, particularly under vacuum pressing conditions, the open matrix structure can become somewhat fixed in this relatively higher bulk density, lower porosity state (i.e., in a relatively more collapsed state). It should be noted that different compressing and drying techniques and/or methods, including different degrees of compressing and drying, can be designed through routine experimentation so as to
20 allow for a material layer having an optimal degree of material bulk density and/or porosity for a particular application or procedure.

In certain aspects, a medical graft product of the invention includes at least two regions exhibiting differing properties, e.g., differing porosities. Such differing
25 regions can be established in certain locations, for example, locations providing a particular arrangement or pattern on and/or within the medical product, and in some forms, such differing regions are formed by subjecting the medical product to a suitable differential drying process. Illustratively, a graft body can be configured so that the capping member occupies a more diminished porosity region, while the
30 elongate plug member occupies a more open porosity region. In this configuration,

the diminished matrix region can help isolate the fistula tract from the alimentary canal, thus inhibiting bacteria and other undesirable substances from passing into the alimentary canal from the fistula, while the more open matrix region serves to promote more rapid closure of the fistula with its desirable remodeling properties.

5

While the present invention may be embodied in many different forms, for the purpose of promoting an understanding of the principles of the present invention, reference will now be made to the embodiments illustrated in the drawings, and specific language will be used to describe the same. It will nevertheless be understood that no limitation of the scope of the invention is thereby intended. Any alterations and further modifications in the described embodiments and any further applications of the principles of the present invention as described herein are contemplated as would normally occur to one skilled in the art to which the invention relates.

10
15

With reference now to Figs. 1A-1D, shown are perspective views of an illustrative medical graft product 10 of the present invention. More specifically, Fig. 1A represents the medical graft product 10 its original configuration, Fig. 1B represents the medical graft product 10 in an intermediate configuration, Fig. 1C represents the medical graft product 10 in its implantable configuration, and Fig. 1D illustrates the medical graft product 10 in its implantable configuration being inserted into a deployment device 17. The medical graft product 10 includes a biocompatible graft body 11 that is configured to block at least the primary opening of a fistula. The graft body 11 includes a capping member 12 and an elongate plug member 13, which extends from the capping member 12. The elongate plug member 13 includes a proximal end 15 and a distal end 16. The capping member 12, which is formed with an ECM material (e.g., SIS), is generally in the shape of a disk and is configured to contact portions of the alimentary canal wall adjacent to the primary opening, particularly those openings occurring within the stomach and/or intestines. The elongate plug member 13, which is also formed with an ECM material, is generally in

20
25
30

the shape of a cylinder and is configured to extend into at least a portion of the fistula tract. The capping member 12 is hingedly coupled to the distal end 16 of the elongate plug member 13 by suture 14. It should be noted that the elongate plug member 13 (and any other plug member described herein) may or may not be sized and shaped to fill an entire fistula tract.

With regard to the intermediate configuration, Fig. 1B illustrates the medical graft product depicted in Fig. 1A where the capping member 12 is swung over the elongate plug member 13 from distal end 16 towards proximal end 15. This process is made possible by the hinged coupling of the capping member 12 to the distal end 16 of the elongate plug member 13. Typically, the capping member 12 will be loosely coupled to the elongate plug member such that the capping member 12 can be easily folded over the elongate plug member by a practitioner or during a manufacturing process. Once positioned at least partially overlapping plug member 13, the capping member 12 can be rolled or wrapped around the elongate plug member 13 as shown in Fig. 1C to arrive at the implantable configuration. In the implantable configuration shown, device 10 includes a portion of the capping member 12 conformed around plug member 13 and a leading portion of capping member 12 extending distally beyond the distal end of plug member 13. Other configurations in which at least a portion of the capping member 12 is conformed to the outer surface of plug member 13 can also be used. Once in its implantable configuration, the medical graft product 10 can be inserted into deployment device 17 and can be implanted within a patient so that capping member 12 contacts portions of alimentary canal wall adjacent to a primary opening, and the elongate plug member 13 extends into at least a portion of fistula tract. To facilitate visualization during deployment, deployment device 17 can have a radiopaque band 18 or other marker positioned at its distal end. In this manner, fluoroscopic imaging can be used to track the position of the distal end of delivery device 17, for instance to identify the point at which such distal end has entered the alimentary canal. Once the medical graft product is delivered, the capping member can regain its original shape or otherwise expand and thus contact portions of

an alimentary canal wall adjacent to the primary opening of a fistula when graft 11 is pulled proximally.

An alternative graft embodiment 10' is depicted in Fig. 1E. This graft device
5 is similar to that depicted in Figs. 1A-1D, except that it also includes a suture material or another tether 19' passed through a central lumen 20' and attached to the capping member. This tether can provide means for adjusting the position of the device during and/or after deployment, and potentially also provide means for anchoring the device, for example, by suturing device 10' to patient tissue at or
10 adjacent to a fistula opening. In one mode of use, after deployment of graft 10' from the lumen of a delivery device as discussed above, tether 19' can be used to pull graft device 10' in a proximal direction to lodge capping member 12' against the wall of the alimentary canal. For these purposes, it will be understood that other modes of attachment of tether 19' to any suitable location of graft device 10' could be used, so
15 long as they enable repositioning the graft device 10' by pulling on the tether 19'.

In another form, a graft device having a lumen such as that depicted in Fig. 1E, the lumen also extending through capping member 12', can be delivered over the wire in order to treat the fistula. Such a graft device can have tether 19' or can
20 optionally lack the tether 19'. Delivery over the wire can be facilitated using a cannulated pusher to force the graft device 10' along the wire, e.g. starting from the fistula opening in the skin and continuing until the capping member 12' enters the alimentary canal and expands, generally as discussed above. In such embodiments, the presence of a tether attached at some point to the device 10' (e.g. to the capping
25 member as depicted or at or near the proximal end of device 10' opposite the capping member) can provide a means by which the device 10' can then be pulled proximally to lodge capping member 12' against the canal wall.

In certain forms of the invention, a graft product incorporates an anchoring
30 adaptation to maintain the capping member in contact with portions of the alimentary

canal wall adjacent the primary opening following product implantation. For example, the medical graft product of the invention can include an adhesive for maintaining this type of contact. Adhesive can be applied to the graft product before an implantation procedure, e.g., during manufacture of the product, or alternatively, 5 can be applied to the graft product and/or to tissue at or near the primary opening during such an implantation procedure. Other suitable anchoring adaptations include but are not limited to barbs, hooks, sutures, protuberances, ribs, and the like. Again, such anchoring adaptations, while advantageous in certain forms of the invention, are not necessary to broader aspects of the invention. Illustratively, certain medical graft 10 products are configured so that the capping member is able to maintain contact with portions of the alimentary canal wall adjacent to the primary opening following implantation without the need for such anchoring adaptations. In other aspects, suitable anchoring adaptations aid or facilitate the maintenance of such contact. In embodiments where the capping member is constructed so as to fit within a 15 deployment device, such as the one depicted in Figs. 1A-1D, such anchoring adaptations will be selected so as not to interfere with this process (i.e., the anchoring adaptations, if any, will not obstruct the medical graft product from being easily loaded and deployed from said deployment device).

20 In certain aspects, the invention provides biocompatible graft bodies that include an expandable element (e.g., an expandable material and/or device). In this regard, inventive graft bodies may be provided, wherein the capping member, the elongate plug member, or both have the capacity to expand. For example, the capping member and/or the elongate plug member can include, for example, a suitable ECM 25 foam or sponge form material. Illustratively, a graft body, or any portion thereof, may comprise a porous, three-dimensionally stable body formed with one or more suitable biocompatible matrix materials. Such biocompatible matrix materials can include naturally-occurring polymers and/or synthetic polymers. More preferred sponge compositions will comprise collagen as a matrix-forming material, either alone or in 30 combination with one or more other matrix forming materials, and particularly

preferred sponge compositions will comprise an ECM material such as those discussed elsewhere herein. In general, sponge matrices useful in certain embodiments of the present invention can be formed by providing a liquid solution or suspension of a matrix-forming material, and causing the material to form a porous
5 three-dimensionally stable structure; however, a sponge or foam material can be formed using any suitable formation method, as is known in the art. For additional information concerning foam or sponge form materials that can be useful in certain embodiments of the present invention, reference can be made, for example, to U.S. Pat. App. Pub. No. 2003/0013989.

10

In some forms, a compact, stabilized sponge construct used to form the elongate graft body and/or capping member is highly expansive when wetted, which can desirably enhance the ability of the graft body to block (and to continue blocking) at least the primary opening of a fistula. In illustrative procedures, a suitable hydrant,
15 such as saline, may be applied or delivered to the graft body after it is suitably located within a patient to enhance the expansion of the body within the fistula tract and/or a fistula opening. Alternatively, or additionally, a bodily fluid of the patient can sufficiently wet the implanted graft body so as to promote the expansion of the body within the fistula.

20

These compact, stabilized sponge constructs and other expandable graft body elements, when used in the invention, can allow the graft body to attain a more low-profile configuration during a deployment step. For example, an illustrative deployment system can include a graft body, wherein the capping member (and
25 optionally also the elongate plug member) is comprised of an expandable device and/or material such that in a stabilized, compressed first configuration, the graft body can fit within an end of a delivery device (e.g., a probing device, delivery sheath, or other similar instrument), which is sized and configured to traverse a fistula tract. Illustratively, this end of the delivery device can be passed into a secondary opening,
30 through a fistula tract, and out of a primary opening into the alimentary canal.

Thereafter, the graft body (or at least the capping member portion of the graft body) can be pushed or otherwise removed from the delivery device in a suitable manner to allow the capping member to attain an expanded second configuration. In such an expanded configuration, the capping member, which was previously able to traverse
5 the primary fistula opening, is now sized and shaped to contact portions of the alimentary canal wall adjacent the primary opening so that at least a portion of the capping member cannot pass back through the primary opening.

Additionally, in illustrative embodiments, one or more anchors, barbs, ribs,
10 protuberances, and/or other suitable surface modifications can be incorporated on and/or within an illustrative graft body to roughen, condition, or otherwise de-epithelialize at least a portion of the fistula, such as the fistula tract and/or the primary opening, during and/or after emplacement of the graft within the tract. The conditioning of the tract tissue can serve to initiate a localized healing response in
15 patient tissue that can be advantageous in enhancing the ingrowth of patient tissue into an illustrative plug construct, such as a plug comprising an ECM material. Further, in illustrative embodiments, where a suture, leader, or string is used to assist with the emplacement of an illustrative graft construct within a tract, as is discussed elsewhere herein, the leader can comprise an abrasive material, or comprise one or
20 more sections and/or surface features and/or adaptations, e.g. one or more bristles that can directionally emanate from the leader material and that can serve to roughen or otherwise condition or de-epithelialize patient tissue upon travel through and/or location within a fistula tract.

25 In certain aspects, medical graft products of the invention incorporate an adhesive or, where appropriate, a sclerosing agent to facilitate and/or promote blocking of at least the primary opening of the fistula. As well, fistula treatment methods of the invention can include steps where such substances or materials are applied to a medical graft product being deployed and/or to the soft tissues
30 surrounding the fistula. For example, an adhesive, glue or other bonding agent may

also be used in achieving a bond between a medical graft product of the invention and the soft tissues defining a fistula opening or tract and/or adjacent tissues. Suitable bonding agents may include, for example, fibrin or collagen gels or pastes, gelatin, or other agents including reactive monomers or polymers, e.g., cyanoacrylate adhesives.

5 In some forms of the invention, a fistula treatment method includes contacting soft tissue surfaces surrounding the fistula, e.g., soft tissue surfaces at or near the primary opening and/or soft tissues lining the fistula tract, with a sclerosing agent prior to forcing the sheet from material into the fistula. Such use of a sclerosing agent can de-epithelialize or otherwise damage or disrupt these soft tissue surfaces, leading to the

10 initiation of a healing response.

A plurality of passages formed or otherwise occurring in a graft body may be present in any suitable number in an inventive product. These passages can exhibit a variety of shapes and sizes, and can extend through all or a portion of the body. In

15 some forms, one or more passages extend from a graft body surface and includes a generally coherent passage wall. Illustratively, a tubular graft body having an internal lumen extending through the body along its length can have passages extending partially or entirely through a wall of the tube, e.g., from an exterior surface to an interior surface of the tube wall. Also, the spacing and size of a passage in a graft

20 body relative to another passage in the body, as well as the depth to which a particular passage extends into a graft body, can vary. In some forms, the passages are generally cylindrical voids, e.g., having diameters ranging from about 0.05 mm to about 15 mm, more typically from about 0.10 mm to about 5 mm, and even more typically from about 0.1 mm to about 1.0 mm. These and other graft body passages

25 useful in the present invention can be spaced any suitable distance from one another, and in some embodiments, are positioned in a particular pattern (e.g., in rows), although a plurality of passages can be randomly placed as well. Further, a plurality of passages in a construct can be configured so that any one passage extends the same or a different distance into the construct relative to any other passage in the construct.

Further in this regard, passages occurring in a graft body may be formed in any suitable manner. In some embodiments, passages can be created in a graft body after the graft body is formed, e.g., after a cast collagenous material is dried to form a coherent body. In some embodiments, at least part of the formation of some or all of the passages in a graft body occurs during formation of the graft body. Illustratively, an inventive method can include a step where a passage is initially provided in a hydrated material mass, e.g., by displacing a volume of material in the mass. Then, with the passages present in the hydrated material mass, the mass can be subjected to suitable drying conditions (e.g., a lyophilization step) to cause or allow the passages to be retained in the dried graft body. It should be noted that a hydrated material in such processes (e.g., a reconstituted or naturally-derived collagenous material) can have a level of hydration including full or partial hydration, and in this regard, a drying process can be used to lower starting material hydration to any suitable level including substantially dehydrated. Also, displacing a volume of material in a hydrated mass of material to create a passage can be accomplished in a variety of manners, and in certain aspects, involves forcing or otherwise introducing an implement or other material-displacing object (e.g., a cannulated or non-cannulated needle) into the mass. Other suitable material-displacing objects can be selected according to the type of passage desired.

20

Turning now to a general discussion regarding methods of the invention for treating fistulae, suitable treatment methods include providing a medical graft product such as any of those described above, and implanting the product within a patient so that: (i) the graft body blocks at least the primary opening of a fistula, i.e., the primary opening and potentially one or more other segments of a fistula, for example, the fistula tract and/or any secondary openings; (ii) the capping member contacts portions of the alimentary canal wall adjacent to the primary opening; and (iii) the elongate plug member extends into at least a portion of the fistula tract. In some modes of operation, the distal end of a deployment device can be inserted into a fistula, for example, into a secondary opening, through a fistula tract, and a distance

30

out of the primary opening. Thereafter, the graft body (or at least the capping member) can be removed from the device, for example with a push rod or other suitable device, allowing the capping member to expand or to at least retain its original shape prior to loading of the graft body into the deployment device. Then, 5 the graft body can be pulled back through the fistula tract until the capping member contacts portions of the alimentary canal wall adjacent to the primary opening. The delivery device can then be withdrawn from the fistula through the secondary opening, leaving the deformed sheet-form material deployed within at least a portion of the fistula tract, and potentially filling at least a portion of the fistula tract, the 10 primary opening, and/or any secondary openings of the fistula.

Products and methods of the invention can be used to treat any fistula, and in particular embodiments, fistulae having a primary opening in a wall of the alimentary canal, such as those occurring in the stomach or intestine. In some aspects, the 15 invention provides medical graft products and methods useful for blocking openings anywhere on or within the body of a patient, for example, blocking at least the primary opening of a urethro-vaginal fistulae, vesico-vaginal fistulae, tracheo-esophageal fistulae, gastrointestinal fistulae, and any number of anorectal fistulae, such as recto-vaginal fistula, recto-vesical fistulae, recto-urethral fistulae, or recto- 20 prostatic fistulae. In preferred embodiments, the medical graft products of the invention are designed to treat a gastrointestinal fistula, such as an enterocutaneous fistula. Also, inventive products and methods can be used to treat a fistula regardless of its size and shape, and in some forms, are utilized to treat a fistula having a primary opening, secondary opening, and/or fistula tract with a diameter ranging from about 1 25 millimeter to about 20 millimeters, more typically from about 5 millimeters to about 10 millimeters.

Medical products of the invention can be implanted using any suitable delivery method or placement technique. Illustratively, a graft body can be implanted 30 by pulling or pushing the graft body into a suitable position within a fistula. For

example, the elongate plug member end of the body can be pulled toward a secondary opening within the fistula tract (e.g., through the primary opening and into the fistula tract) until the capping member contacts portions of the alimentary canal wall adjacent to the primary opening. In certain embodiments, such pulling can be accomplished using a fistula probe or other suitable instrument, for example, an appropriately configured pair of surgical hemostats that include a portion passable into a secondary opening, through the fistula tract, and potentially out of the primary opening. Thereafter, the elongate plug member portion of the graft body can be releasably grasped by the probe or otherwise coupled to the probe and pulled into the primary opening. In other embodiments, an illustrative graft body is suitably deployed using a biocompatible sheath or catheter, which can be configured to traverse the tract of a fistula, and is optionally located within the fistula tract over a suitable wire guide or under endoscopic guidance. In these embodiments, an illustrative graft construct can be deployed in an over-the-wire configuration or through an unobstructed sheath lumen. In addition to those described elsewhere herein, suitable delivery devices and systems useful in such embodiments of the invention can be prepared and used, for example, as described in International Patent Application Serial No. PCT/US2007/061380, filed January 31, 2007, and entitled "FISTULA GRAFT DEPLOYMENT SYSTEMS AND METHODS" (Cook Biotech Incorporated), which is hereby incorporated by reference in its entirety.

Fistula treatment methods of the invention may include an endoscopic visualization (fistuloscopy) step. Such endoscopic visualization can be used, for example, to determine the shape and size of the fistula, which in turn can be used to select an appropriately sized and shaped medical graft product for treating the fistula. Illustratively, a very thin flexible endoscope can be inserted into a secondary opening of the fistula and advanced under direct vision through the fistula tract and out through the primary opening. By performing fistuloscopy of the fistula, the primary opening can be accurately identified. Also, cleaning of the fistula can be performed prior to and/or during deployment of a medical graft product of the invention. For

example, an irrigating fluid can be used to remove any inflammatory or necrotic tissue located within the fistula prior to engrafting the product. In certain embodiments, one or more antibiotics are applied to the medical graft product and/or the soft tissues surrounding the fistula as an extra precaution or means of treating any residual
5 infection within the fistula.

The present invention also provides, in certain aspects, medical products that include a radiopaque element such as but not limited to a radiopaque coating, attached radiopaque object, or integrated radiopaque substance. In this regard, the capping
10 member and/or elongate plug member of some inventive graft bodies may be comprised of a radiopaque element so that, for example, the movement of the product may be monitored and the product may be placed at a desired location. Any suitable radiopaque substance, including but not limited to, tantalum such as tantalum powder, can be incorporated into a medical product of the invention. Other radiopaque
15 materials comprise bismuth, iodine, and barium, as well as other suitable markers.

The capping members described herein can be shaped and configured in a variety of manners. In some instances, a capping member includes a resilient wire frame or other similar frame or frame-like support device. These devices can, in some
20 embodiments, be designed to move between a first device configuration and a second device configuration, for example, in the case of a frame that is compactable to a compacted, first condition, and when in this compacted condition, is then expandable to an expanded, second condition. In forms where a frame has the capacity to expand, these frames can include those that are self-expanding and those that require at least
25 some manipulation in order to expand. In certain embodiments, an inventive support frame is unable to freely fit inside a delivery device lumen when in a first condition (e.g., in a generally relaxed state), but then can be manipulated into a second condition for placement in the lumen. In the lumen, the frame is constrained by interior device surfaces that define the lumen. Upon removal from the lumen, the
30 frame then generally returns to the first condition.

With reference now to Figure 2A, shown is a support frame 40 which can be incorporated into a grafting device of the invention. Support frames of this sort and other similar devices useful in the present invention can be constructed using one or more pieces of stainless steel wire, superelastic wire or any of a variety of other suitable materials described herein or otherwise known to those skilled in the art. In this particular embodiment, support frame 40 includes a single piece of Nitinol wire having a plurality of sides and bends interconnecting adjacent sides. Bends of this sort can include coils, fillets, or other suitable configurations, for example, those designed to reduce stress and fatigue. Support frame 40 incorporates optional bend adaptations 41 having apertures occurring therein as generally shown. The single piece of wire is preferably connected to itself by an attachment mechanism, such as a piece of cannula and solder, to form a closed circumference frame. In some aspects, a closed circumference frame (e.g., an octagonal frame) rather than being constructed by joining together parts of one or more other objects (e.g., ends of a single piece of wire) is instead formed as a closed circumference frame, for example, as a unitary device in a mold or form, or developed from a larger piece of material (e.g., laser cut from a metallic sheet of material). While a preferred frame embodiment is an eight-sided polygon such as that shown in Figure 2A, other shapes having rectilinear and/or curvilinear components are contemplated as well, for example, circular or oval shapes or other polygonal shapes having three, four, five, six, seven or any suitable number of sides.

Support frame 40, which is shown in a relaxed condition in Figure 2A, is a resilient device. Thus, the frame can be deformed (e.g., collapsed, compressed, etc.) from this relaxed, first condition to a deformed, second condition. In this deformed, second condition, the resilient frame is then poised to essentially return to its relaxed, first condition. Illustratively, support frame 40 can be compressed into a compressed condition (e.g., by folding one or more times and/or rolling portions of the frame) for positioning in a delivery device lumen having a relatively smaller diameter than that

which the frame could otherwise fit in its relaxed condition. In this compressed condition, the frame then has the ability to self-expand essentially back to its prior, relaxed condition upon being removed from the delivery device lumen.

5 In a preferred embodiment, a capping member includes a support frame and a deformable covering material. The support frame and covering material can each be formed with one or more of a variety of materials. Illustratively, a support frame formed with a resilient material (e.g., Nitinol) can be combined with a sheet-form resorbable or non-resorbable material, and in some cases, a multilayered (e.g.,
10 remodelable) material, wherein this combination provides a suitable arrangement for blocking, and in some cases sealing off, a fistula opening. Arrangements of this sort include but are not limited to capping members that include a support frame that can lie in a single, generally flat plane, and a sheet-form deformable covering material extending between peripheral regions of the support frame, although a variety of other
15 capping member shapes and configurations are contemplated as within the scope of the present invention. Some of these devices can be used to treat fistulae having a primary opening in a bowel wall, and in this regard, may be effective to block or otherwise exclude the bowel lumen from the fistula tract when desirably deployed.

20 Covering materials can be manipulated before, during and/or after being combined with a support member. In some cases, a covering material will be already-formed before being associated with a support frame. In other cases, a covering material will be fully or partially formed in the presence of a support frame or portion thereof. When present, a covering material that is to be combined with a support
25 device can be attached to or otherwise suitably associated with the support device in a variety of manners including some that involve bonding and/or mechanically fastening the covering material to the device. In some cases, an edge of a covering material is folded over a frame segment and attached to another portion of the material to provide a sleeve or other channel-like adaptation for retaining the covering
30 material in association with the support frame.

Certain embodiments of the invention provide capping members including an expandable or otherwise deformable frame member associated with a full or partial covering of material on one or more surfaces of (e.g., an inner and/or outer surface) of the expandable frame member. In some embodiments, the covering material is associated in a unique manner with the expandable frame member. For example, the covering material may be contoured snugly around or completely or partially embed elements of the expandable frame member to assist in maintaining the attachment of the covering material to the expandable frame member. This may avoid, reduce, or simplify the need for other mechanical attachments, such as sutures, to hold the covering material to the expandable frame member. It may also in some forms provide a unique, relatively fixed association of the covering material with the expandable frame member or elements thereof, even during contraction and/or expansion of the frame. Illustratively, coverings that completely or partially embed a frame member can be made by casting a polymerizable, crosslinkable or otherwise hardenable flowable material onto and around all or a portion of the frame member, and then causing the flowable material to polymerize, crosslink and/or otherwise harden. In some other cases, a flexible material can be positioned around a frame, and then the material physically, chemically and/or otherwise altered (e.g., via lyophilization, heating, etc.) so that the material becomes less flexible for maintaining the material in association with the frame.

Capping member support frames, when used in the present invention, can be associated with one or more of a variety of materials to form effective capping arrangements. Useful covering and other materials for capping purposes include naturally-derived and non-naturally-derived materials such as those described elsewhere herein. Both resorbable and non-resorbable materials may be employed in this regard. In some preferred embodiments, polymeric materials are associated with support structures to form useful capping members. These include synthetic and non-synthetic polymers. These various materials can be applied to or otherwise associated

with support members in a variety of manners including some that involve mechanical fastening of an already-formed material, forming material along and/or around portions of the frame (e.g., in a mold or form, by spray coating, dip coating, etc.), thermoforming, solvent dissolution, and variations and combinations thereof.

5

In some cases, a flexible covering material that is pulled taught along a collapsible support frame can fold and/or roll along with a frame as it collapses, and upon the frame returning to its prior shape, can also essentially return to its prior condition to again be pulled taught. Referring now to Figure 2B, shown is a capping member 50 that incorporates the support frame from Figure 2A. Capping member 50 additionally includes a deformable covering material 52 attached to and extending between opposing, peripheral edges of the frame. In a preferred embodiment, capping member 50 will generally be sized and configured so that when positioned over a fistula opening in a bodily structure wall (e.g., a primary fistula opening in an alimentary canal wall), outer regions of the capping member (i.e., those including the support frame) extend beyond the opening along the bodily structure wall and contact portions of the bodily structure wall adjacent to the opening, and inner regions of the capping member cover and block the opening.

15

In some cases, a capping member such as capping member 50 will include at least one elongate device (e.g., a suture, plug member, etc.) extending therefrom. For example, an elongate plug can be connected to (e.g., sutured, glued, etc.) covering material 52 such as in a region of the material that is centrally located relative to the support frame perimeter. In this manner, the device can be positioned in a patient such that capping member 50 is positioned over a fistula opening, and the elongate plug member extends into a fistula tract extending from this opening. In this position, the elongate plug member can be pulled away from the capped fistula opening such that portions of deformable covering material 52 are drawn into the fistula tract. Desirably, support frame 40 provides an anchor of sorts for capping member 50 so that as inner regions of covering material 52 are drawn into the fistula tract, support

20

25

30

frame 40 and outer regions of covering material 52 remain outside of the fistula tract. In some cases, when a sufficiently flexible covering material is pulled in this manner, portions of the covering material can deform to provide a convex or other similar surface for contacting patient tissue at the fistula opening to seal or substantially seal
5 off the opening.

Figures 3A and 3B show a medical graft device 60 of the present invention that includes a capping member 70 and a generally cylindrical, elongate plug member 72 extending from this capping member. Plug member 72 is configured to extend
10 into and fill at least a portion of a fistula tract, and its dimensions including its length can vary, with those skilled in the art recognizing suitable plug dimensions for a particular application. In some cases, a plug length is provided for extending through an entire fistula tract up to about 15 cm or longer, although such a plug could be cut to size as desired to fit all or a portion of a particular tract. As well, elongate plug
15 member 72 can be formed with one or more of a variety of materials, and in some preferred embodiments, is formed with a rolled sheet-form material such as but not limited to a single- or multi-layered naturally-derived material (e.g., a collagenous ECM material). Capping member 70, which includes a deformable covering material 73, is similar to that shown in Figure 2B except that it additionally includes a sheath
20 portion 74 extending away (in a generally perpendicular direction) from a centrally-located region of its bottom surface. Capping member 70 includes a top surface 76. Sheath portion 74 is configured to be positioned over and extend along at least a segment of plug member 72 as generally shown in Figure 3A. A plurality of sutures
25 78 attach sheath portion 74 to plug member 72, although a variety of other attachments means are contemplated as within the scope of the present invention.

A capping member sheath portion useful in the invention can be formed separately from, and then subsequently united with, the remainder of a capping member, or alternatively, can be formed as part of an existing capping member
30 component. In this particular embodiment, sheath portion 74 comprises a portion of

covering material 72 extending away from the remainder of the capping member. Illustratively, a sheath portion of this sort can be formed by providing a covering material sufficiently sized to be wrapped around a support frame with enough material left over on one side to form a sheath or sheath-like capping member component. In some cases, a somewhat flexible material is positioned around a frame in such a manner, and then the material is physically, chemically and/or otherwise treated (e.g., lyophilized, heated, etc.) so that the material becomes less flexible for maintaining the material in the desired configuration.

Referring again to Figure 3B, in some modes of use, graft device 60 is implanted within a patient such that capping member 70 is positioned over a fistula opening 80 occurring in a bodily structure wall 90, and elongate plug member 72 extends into a fistula tract 91 extending from this opening. In this position, plug member 72 can be pulled in the direction of the arrow shown (i.e., away from the capped fistula opening) such that portions of deformable covering material 73 are drawn into the fistula tract as generally shown. In an alternative embodiment, graft device 60 incorporates a tether extending from elongate plug member 72 (e.g., away from the end opposite capping member 70), which may be useful in manipulating the position the device at certain points during delivery. A tether of this sort may be a suture (e.g., a 2-0 vicryl suture) embedded within, attached to or otherwise associated with plug member 72.

Desirably, the support frame will be sized and configured so that it remains outside of the fistula tract (e.g., along the bodily structure wall in an area extending a suitable distance beyond the fistula opening) even when a considerable amount of pulling force is applied to plug member 72. In this manner, when capping member 70 is deformed as shown in Figure 3B, the support frame and an externally remaining portion 100 of the covering material will remain outside of the fistula tract, while a portion of the covering material that previously (i.e., prior to deformation) resided outside of the fistula tract will now reside within the fistula tract to provide an

internalized covering material portion 101. In some forms, the capping member is deformed so that portions of the covering material very snugly conform to patient tissue at the fistula opening in a generally non-planar condition such as a cupping or cup-like arrangement. The plug member 72 can then be secured in position, e.g.,
5 using one or more sutures to patient tissue, to retain the conforming condition of the capping member.

Graft device 60 and other similar inventive devices are particularly suitable for treating enterocutaneous and other gastrointestinal fistulae, although such devices can
10 be adapted to treat a variety of other fistulae as well. These devices can be implanted in any suitable manner. In a preferred embodiment, graft device 60 is placed with the aid of a delivery sheath or other similar delivery device, for example, a splittable sheath as discussed in more detail below. In one mode of operation, the distal end of a wire guide is passed into an enterocutaneous fistula tract through a secondary fistula
15 opening and toward a primary fistula opening under fluoroscopic guidance. The wire is advanced until its distal end enters the alimentary canal through the primary opening. Thereafter, the distal end of an over-the-wire dilator-sheath combination is advanced through the tract in a similar manner, for example, until the sheath is positioned at or just beyond the primary opening. The dilator is then removed,
20 leaving the sheath (e.g., a check-flow sheath) and potentially also the guidewire in the tract. In some cases, the wire guide is removed with the dilator. Then, a suitably sized and shaped graft device such as graft device 60 is loaded into the sheath through its proximal end, for example, with the capping member 70 in a compressed condition (e.g., folded one or more times and/or rolled) entering the sheath first, and elongate
25 plug member 72 following. The plug member may then be fully pushed into the sheath by hand. The capping member, in a compressed condition, is poised to return to its expanded condition upon being removed from the delivery device lumen.

Next, an over-the-wire pusher is introduced into the sheath proximal end and
30 advanced toward the sheath distal end until at least a portion of the graft device is

desirably pushed from the sheath distal end (e.g., with capping member 70 in an expanded condition and extending a distance into the alimentary canal). In some cases, the capping member and/or plug member will incorporate a device or material to aid in imaging the device during delivery. Illustratively, a stainless steel button or other similar device may be attached to the end of the plug member near the capping member. As well, a capping member support frame can be formed with a radiopaque material. Alternatively, a support frame can be formed with a resorbable material such as a collagenous ECM material (e.g., SIS), polycaprolactone, polyhydroxyalkanoates- or PHA polymers, etc. with a radiopaque marker attached.

10

Then, the pusher can be placed in contact with the plug member 72 to provide back pressure, while the delivery sheath is removed, thus maintaining desirable positioning of the device inside the tract. After the sheath and pusher are removed, plug member 72 can be manipulated to achieve a desired deformation of capping member 70, for example, as described above. With capping member 70 desirably deformed, plug member 72 can then be secured in place (e.g., sutured or otherwise fixed to patient tissue at and/or around the secondary fistula opening) to maintain the capping member in this deformed condition. In some cases, the plug member will extend a distance out of the secondary opening when the capping member is deformed. This portion may optionally be trimmed off before or after the plug is secured in place. Although not necessary to broader aspects of the present invention, in the current embodiment, plug member 72 is directly or indirectly attached to the underside of the material defining the capping member top surface 76, and in this regard, internalized covering material portion 101 includes some of the material defining this surface. In one aspect, a support frame is attached to a covering material with resorbable sutures, allowing the frame to separate from the remainder of the graft device after a certain amount of time following initial plug deployment, and pass through and out of the alimentary canal.

25

In some preferred embodiments, care is taken to not block or otherwise close the secondary opening to facilitate drainage of the tract following the implantation procedure, for example, during remodeling when a remodelable material is utilized in the plugging assembly. Of course, it will be understood that the steps described above can occur in any suitable order as will be recognized by those skilled in the art. For example, a graft device may be preloaded into a delivery device before the delivery device is positioned in a fistula tract. In some cases, when a delivery system component (e.g., a wire guide, dilator, pusher, etc.) is deemed not necessary for a particular delivery application, this component will be excluded from the delivery system and any associated methods of delivery.

Figure 4A shows a medical graft device 120 according to another embodiment of the present invention. Device 120 includes a capping member 121 and an elongate plug member 122 extending from the capping member. Plug member 122 is configured to extend into and potentially fill a fistula tract. Such a plug member may be formed as described elsewhere herein, for example, as described in regard to the plug member depicted in Figures 3A and 3B. In some cases, a plug of this sort will have a length ranging from about 10 cm to about 20 cm, more typically from about 15 cm to about 18 cm.

Capping member 121 is comprised of a deformable material 123 having portions extending between outer edges of an octagonal, resilient support frame 124. Support frame 124 is a closed circumference frame made of Nitinol. In some preferred embodiments, the deformable material is comprised of a polymeric material, e.g., a synthetic polymeric material such as but not limited to polyurethane materials such as THORALON®, thermoplastic silicones, etc. In some instances, a naturally-derived material such as an ECM or other naturally-derived material is additionally or alternatively included. Such materials may be coated with other material(s), for example, a PCL-coated or PLGA-coated collagenous material (e.g., a coated SIS material). Such materials may be fully or partially formed on and/or around a support

frame, or alternatively, may be provided as a separate component and then suitably combined with the support frame. In a preferred embodiment, a synthetic polymer is desirably thermoformed around a support frame to fully or partially embed parts of the support frame.

5

Capping member 121 includes a top surface 127, which is configured to face the bowel lumen when the device is desirably implanted within a fistula. Deformable material 123 also provides a sheath portion 128 extending away (in a generally perpendicular direction) from a centrally-located region of the bottom surface of the capping member. Sheath portion 128 is configured to be positioned over and extend
10 along at least a segment of plug member 122 as generally shown in Figure 4A. A plurality of sutures 129 attach sheath portion 128 to plug member 122, although a variety of other attachments means are contemplated as within the scope of the present invention. A stainless steel or other suitable radiopaque marker may be
15 incorporated into a distal region of device 120. A tether 130 (e.g., suture material) is attached to the plug body near its proximal end, and can extend proximally away from the plug body to potentially aid in product handling and/or delivery.

Device 120 can be delivered into a fistula tract in any suitable manner
20 including that described above in relation to Figures 3A and 3B. In one embodiment, capping member 121 is positioned in a delivery lumen such that a first edge portion of capping member 121 is deflected toward the proximal end of plug member 122, while a second (opposite) edge portion of capping member 121 is deflected generally in the opposite direction (i.e., away from the proximal end of plug member 122). In such a
25 condition, a portion of capping member 121 will overlap or otherwise extend back over and potentially wrap and conform to an exterior, lateral surface of plug member 122, while another portion of capping member 121 will extend out in front of the distal end of plug member 122, although other folding or compaction patterns could be used in certain embodiments. An example of how device 120 can be positioned in
30 a delivery device lumen is depicted in Figure 4B. So positioned, the capping member

is poised to return to its generally non-deformed condition upon being removed from the lumen of delivery device 131.

In some forms, capping member portions, which would otherwise be
5 essentially perpendicular to the longitudinal axis of the plug member when the
capping member is in a generally relaxed condition, can be made to reside in a
parallel (or closer to parallel) position relative to this longitudinal axis. When
positioned in a delivery device lumen, these capping member portions may be
constrained by and/or conform to interior walls of the delivery device defining the
10 lumen. As well, any portions of the capping member extending along exterior, lateral
surfaces of the plug member may at least somewhat conform to these plug member
surfaces.

Plug member 122 is generally cylindrical, with a substantial portion of the
15 plug having a first diameter. Near its distal end, the plug tapers to a second, smaller
diameter as shown. This smaller diameter distal end region may be useful to receive
or otherwise accommodate portions of the capping member which might be folded
back over the plug member when device 120 is loaded into a delivery sheath,
potentially allowing use of a reduced diameter delivery sheath. Such recesses or other
20 similar spaces for receiving or otherwise accommodating at least part of a capping
member residing along a plug member portion will be recognized by those skilled in
the art, and therefore, are encompassed by the present invention. Device 120
additionally includes a thin cover 133, which is somewhat snugly positioned over
plug member 122. Cover 133 can be formed with any suitable material (e.g., a
25 synthetic polymer), and may be useful to protect the device during product storage,
handling and/or delivery. Device 120 may be sterilized before and/or after placement
in cover 133. In one mode of delivery, device 120 is transferred directly from cover
133 and into an emplaced catheter or other similar delivery device so that the plug
body 122 does not have to be directly touched by the physician during deployment.

Delivery devices useful in certain aspects of the present invention have a lumen communicating with a distal, open end. This “leading” distal end is configured to pass into passageways and other open spaces in the body. Although not necessary to broader aspects of the invention, this distal end, or any portion thereof, may be particularly configured to enhance travel of the device through certain body passageways, for example, including a tapered portion and/or having a dome-shaped or otherwise rounded tip. Accordingly, such devices can exhibit any suitable size, shape and configuration for performing the functions described herein, while avoiding substantially cutting or tearing surrounding soft tissues.

10

Where a delivery device is used to deliver a graft device into a fistula tract, such a device may have a length of about 2 inches to about 12 inches, more typically about 3 inches to about 9 inches, and even more typically about 4 to about 8 inches. Also, these devices may have an outside diameter of about 0.3 mm to about 3.2 mm, more typically about 0.5 to about 3.0 mm, and even more typically about 1.0 mm to about 2.5 mm.

15

In some embodiments, a delivery device is rigid or substantially rigid, and is configured to be generally straight, for example, for use in treating certain simple or straight fistulae. Alternatively, delivery devices useful in the invention can be configured to include one or more portions that are curvilinear, bent, or otherwise suitably shaped. In certain aspects, the distal end of a delivery device is curved to a degree to allow for easier passage of the distal end through a complex fistula, e.g., a horseshoe fistula, and/or through the primary fistula opening and into the alimentary canal. In some forms, a delivery device is composed of a malleable material such as but not limited to a woven or spirally-configured metal or alloy material, or a plastic (hydrocarbon-based) material, which may be bent to the necessary angle or curvature, for example, to allow passage through a fistula tract. The shape of such a delivery device may be adjusted at certain intervals of the procedure so as to allow the delivery device to pass further and further into the fistula tract, until the primary opening is

30

identified. In some forms, the delivery device is generally straight in a relaxed condition but can flex to adapt to contours during passage.

In this regard, delivery devices, when used in the invention, can be formed
5 with one or more of a variety of materials. A particular material may be selected to take advantage of one or more of its properties such as but not limited to its weight, durability, flexibility, etc. For example, a device may comprise a material having properties that allow the device to traverse a body passageway without buckling or kinking or causing unacceptable damage to soft tissues defining the passageway.
10 Illustratively, the device, or selected portions thereof (e.g., the distal end), can exhibit a degree of flexibility. In this regard, a delivery device, or any portion thereof, may be rigid, malleable, semi-flexible, or flexible. In certain embodiments, an endoluminally advancable device is particularly adapted for moving through and into body passages that angulate sharply or curve abruptly such as when traversing the
15 alimentary canal, passing through and into a fistula opening, traversing a fistula tract, etc. In some of these embodiments, the device is configured to be directable or steerable through the passageway, and therefore, exhibits desirable characteristics, e.g., sufficient stiffness, to allow an operator to apply an adequate degree of ante-grade force to the device to allow it to traverse a passageway in a desirable manner.

20

Suitable materials for forming delivery devices or device components of the invention can include but are not limited to metallic materials including stainless steel, titanium, cobalt, tantalum, gold, platinum, nickel, iron, copper and the like, as well as alloys of these metals (e.g., cobalt alloys, such as Elgiloy ®, a cobalt-
25 chromium-nickel alloy, MP35N, a nickel-cobalt-chromium-molybdenum alloy, and Nitinol ®, a nickel-titanium alloy). Additionally or alternatively, the delivery device can include material in the form of yarns, fibers, and/or resins, e.g., monofilament yarns, high tenacity polyester, and the like. A delivery device can also include other plastic, resin, polymer, woven, and fabric surgical materials, other conventional
30 synthetic surgical materials, such as a shape-memory plastic, and/or combinations of

such materials. Further, appropriate ceramics can be used, including, without limitation, hydroxyapatite, alumina and pyrolytic carbon.

In some forms, a flexible delivery device will incorporate one or more
5 adaptations for facilitating removal of the device from the body during a delivery
procedure. Illustratively, a protective sleeve can incorporate scores, thinner portions,
and other openings and non-openings that weaken a portion of the sleeve to facilitate
a splitting operation in removing the sleeve from the tract. Such a weakened portion
may include any suitable means for facilitating tearing or breaking along the area. In
10 certain beneficial forms, a protective sleeve is controllably separable longitudinally
into two or more pieces for removal, for example, as occurs in Peel-Away® catheters
available from Cook Incorporated, Bloomington, Indiana, USA. Such an apparatus
with a separable sleeve is particularly useful in treating fistulae that have a secondary
opening in the outer skin surface and a primary opening that is relatively difficult to
15 access other than through the fistula tract, e.g. as occurs in a large percentage of
enterocutaneous fistulae. In one aspect, a delivery system comprises a suitably sized
and configured inner dilator, a splittable sheath, and a “pusher” device that is
translatable through the sheath, wherein all of these can be received over an emplaced
guidewire.

20

In some forms, a fistula is drained prior to receiving a medical graft product of
the invention therein. Such draining can be accomplished by inserting a narrow
diameter rubber drain known as a seton through the fistula. The seton is passed
through the fistula tract and tied as a loop around the contained tissue and left for
25 several weeks or months, prior to definitive closure or sealing of the fistula. This
procedure is usually performed to drain infection from the area, and to mature the
fistula tract prior to a definitive closure procedure.

In one embodiment, a medical graft product of the invention includes a leader
30 in association with the graft body, for example, a suture glued or tied to the graft

body. This leader can be used to pull the graft body into a suitable position within a fistula. In some aspects, after the leader is used to sufficiently locate a suitable fistula graft within a patient, the string can be removed from the graft, for example, using cutting shears. In alternative forms, the string or suture can be made from a
5 remodelable or otherwise absorbable material such that the string or suture can be left in place within the fistula tract. In these forms, the absorbable leader can be used to anchor or otherwise suitably secure the fistula graft within the implantation site. For example, the leader can be tied to patient tissue at a suitable location, for example, a location just inside or external to a secondary fistula opening. Further, in alternative
10 embodiments, an illustrative fistula graft can be positioned so that it spans the entire length of a fistula tract, i.e., from the primary opening to a location at or external to a secondary opening. In these embodiments, the string or suture can be used to secure the tail of the graft to patient tissue at an external location.

15 Medical graft products of the invention can also be sealed within sterile medical packaging. For example, a medical graft product can have packaging including a backing layer and a front film layer. The medical graft product is sealed between the backing layer and the film layer utilizing a boundary of pressure-adhesive as is conventional in medical packaging. A cut-out may be provided in the backing
20 layer to assist a user in separating the film layer from the backing layer.

Sterilization of a medical graft product may be achieved, for example, by irradiation, ethylene oxide gas, or any other suitable sterilization technique, and the materials and other properties of the medical packaging will be selected accordingly.
25 Also, medical graft products of the invention can be contained in sterile packaging in any suitable state. Suitable states include, for example, a hydrated or dehydrated state. The medical graft products can be dehydrated by any means known in the art (e.g., lyophilization or air dried). If a medical graft product of the present invention is stored in a dehydrated state, it is preferred that it retains all of its biological and
30 mechanical properties (e.g., shape, density, flexibility, etc.) upon rehydration.

The materials and other properties of the packaging will be selected accordingly. For example, the package can include indicia to communicate the contents of the package to a person and/or a machine, computer, or other electronic device. Such indicia may include the dimensions of, the type of materials used to form, and/or the physical state of, the contents of the package. In certain embodiments, a medical graft product is packaged for sale with instructions for use. For example, in a particularly preferred embodiment, a medical product includes at least one medical graft product sealed within a sterile package, wherein the packaging has visible indicia identifying the at least one medical graft product as having physical characteristics as described herein, and/or can contain or otherwise be associated with printed materials identifying the contents as having such physical characteristics and including information concerning its use as a medical graft product for treating fistulae. The packaging can also include visible indicia relating to the dimension of the at least medical graft product, and/or relating to the treatment site(s) for which the at least one medical graft product is configured.

The present invention also provides a line of medical products, wherein a medical product of the invention includes one or more medical graft products such as those described herein enclosed within a sealed package. When the medical product includes more than one medical graft product, for example, a plurality of medical graft products, the products can each be of substantially the same size and shape, or, alternatively, can vary with respect to size and shape.

Additionally, the medical graft products of the invention can be modified before, during, and/or after deployment. Illustratively, a product may be cut, trimmed, sterilized, and/or treated (e.g., brought into contact, impregnated, coated, etc.) with one or more desirable compositions, such as any of those previously disclosed herein, e.g., anticoagulants (e.g., heparin), growth factors or other desirable property modifiers. In certain aspects, following deployment of a graft body in

accordance with the present invention, one or more portions of the body are trimmed off or otherwise removed, for example, material protruding from the primary opening and/or any secondary opening.

5 Further, the fistula treatment methods described herein can be used to close one or more fistula during a given medical procedure. Also, methods of the invention can be used to treat complex fistula. For multiple fistulae, multiple medical graft products can be engrafted until each of the fistula have been addressed. In cases of complex fistula, for example a horse-shoe fistula, there may be one primary opening
10 and two or more fistula tracts extending from that opening. In such instances, a medical graft product may be configured with a graft body including one capping member and two or more elongate plug members. Each plug member can be drawn into the primary opening, and thereafter into one of the fistula tracts extending therefrom. Each of the elongate plug members and/or the capping member of the
15 body can be secured by sutures and/or an adhesive, if necessary, and any excess material can be trimmed. Still further, while discussions herein have focused upon the treatment of fistulae, in certain embodiments, medical graft devices of the invention may be configured for and used in the treatment of other undesired voids or tracts through body tissues caused by trauma, disease or other causes, particularly
20 such voids or tracts that originate at an organ wall or other tissue wall and extend into adjacent tissues.

The use of the terms "a" and "an" and "the" and similar referents in the context of describing the invention (especially in the context of the following claims) are to be
25 construed to cover both the singular and the plural, unless otherwise indicated herein or clearly contradicted by context. Recitation of ranges of values herein are merely intended to serve as a shorthand method of referring individually to each separate value falling within the range, unless otherwise indicated herein, and each separate value is incorporated into the specification as if it were individually recited herein.
30 All methods described herein can be performed in any suitable order unless otherwise

indicated herein or otherwise clearly contradicted by context. The use of any and all examples, or exemplary language (e.g., "such as") provided herein, is intended merely to better illuminate the invention and does not pose a limitation on the scope of the invention unless otherwise claimed. No language in the specification should be
5 construed as indicating any non-claimed element as essential to the practice of the invention.

Preferred embodiments of this invention are described herein, including the best mode known to the inventors for carrying out the invention. Of course,
10 variations of those preferred embodiments will become apparent to those of ordinary skill in the art upon reading the foregoing description. The inventors expect skilled artisans to employ such variations as appropriate, and the inventors intend for the invention to be practiced otherwise than as specifically described herein. Accordingly, this invention includes all modifications and equivalents of the subject
15 matter recited in the claims appended hereto as permitted by applicable law. Moreover, any combination of the above-described elements in all possible variations thereof is encompassed by the invention unless otherwise indicated herein or otherwise clearly contradicted by context. In addition, all patents and publications cited herein are indicative of the abilities of those of ordinary skill in the art and are
20 hereby incorporated by reference in their entirety as if individually incorporated by reference and fully set forth.

CLAIMS

What is claimed is:

1. A medical graft product useful for treating a fistula having a primary opening
5 in a wall of the alimentary canal and a fistula tract, the medical graft product
comprising:

a biocompatible graft body configured to block at least the primary opening of
the fistula, said graft body comprising a capping member and an elongate plug
member extending from said capping member, said capping member being hingedly
10 coupled to said elongate plug member and configured to contact portions of the
alimentary canal wall adjacent to the primary opening, said elongate plug member
being configured to extend into at least a portion of the fistula tract.

2. The medical graft product of claim 1, wherein said capping member and said
15 elongate plug member are hingedly coupled to one another with suture material.

3. The medical graft product of claim 1, wherein at least one of said capping
member and said elongate plug member comprises a resorbable material.

20 4. The medical graft product of claim 1, wherein at least one of said capping
member and said elongate plug member comprises a collagenous material.

5. The medical graft product of claim 4, wherein said collagenous material is a
remodelable collagenous material.

25

6. The medical graft product of claim 5, wherein said remodelable collagenous
material comprises an extracellular matrix (ECM) material.

7. The medical graft product of claim 6, wherein said ECM comprises
30 submucosa.

8. The medical graft product of claim 7, wherein said submucosa is intestinal, urinary bladder or stomach submucosa.

5 9. The medical graft product of claim 8, wherein said submucosa is small intestinal submucosa (SIS).

10. The medical graft product of claim 1, wherein said capping member and said elongate plug member are differentially dried.

10

11. The medical graft product of claim 1, wherein said capping member comprises a synthetic material.

12. The medical graft product of claim 1, wherein said capping member comprises a metallic material.

15

13. The medical graft product of claim 1, wherein said capping member includes a support frame supporting a deformable covering material.

14. The medical graft product of claim 1, wherein said deformable covering material comprises a synthetic polymeric material.

20

15. The medical graft product of claim 1, wherein said capping member comprises a biodegradable material.

25

16. The medical graft product of claim 1, wherein said capping member has a portion configured to extend into the primary opening when the medical graft product is implanted.

30

17. The medical graft product of claim 1, wherein said elongate plug member has a portion configured to extend through the primary opening and into the fistula tract when the medical graft product is implanted.

5 18. The medical graft product of claim 1, wherein said elongate plug member is of a length sufficient to extend from the capping member through the fistula tract and out of a secondary opening in the fistula when said medical graft product is implanted.

10 19. The medical graft product of claim 1, wherein said elongate plug member exhibits a tubular shape.

20. The medical graft product of claim 1, wherein the elongate plug member has a cross sectional dimension of from 3mm to 20mm.

15 21. The medical graft product of claim 1, wherein the elongate plug member has a cross sectional dimension of from 5mm to 15mm.

20 22. The medical graft product of claim 1, further comprising a suture in association with said graft body, said suture effective for pulling said graft body into the primary opening.

25 23. The medical graft product of claim 1, further comprising a suture in association with said graft body, said suture effective for holding said capping member in contact with portions of the intestinal wall adjacent to the primary opening.

24. The medical graft product of claim 1, wherein said graft body incorporates an anchoring adaptation for maintaining said capping member in contact with portions of the intestinal wall adjacent to the primary opening.

25. The medical graft product of claim 24, wherein said anchoring adaptation comprises a dried, reversible adhesive disposed on said graft body.

26. A method for treating a fistula having a primary opening in a wall of the
5 alimentary canal and a fistula tract, the method comprising:

providing a medical graft product, said medical graft product comprising a biocompatible graft body configured to block at least the primary opening of the fistula, said graft body including a capping member and an elongate plug member extending from said capping member; said capping member being hingedly coupled
10 to said elongate member; and

implanting said medical graft product within a patient so that said capping member contacts portions of the alimentary canal wall adjacent to the primary opening and said elongate plug member extends into at least a portion of the fistula tract.
15

27. The method of claim 26, wherein said capping member and said elongate plug member are hingedly coupled to one another with suture material.

28. The method of claim 26, wherein at least one of said capping member and said
20 elongate plug member comprises a collagenous material.

29. The method of claim 28, wherein said collagenous material is a remodelable collagenous material.

30. The method of claim 29, wherein said remodelable collagenous material
25 comprises an extracellular matrix (ECM) material.

31. The method of claim 26, wherein said elongate plug member is of a length sufficient to extend from the capping member through the fistula tract and out
30 of a secondary opening in the fistula when said medical graft product is implanted.

32. A medical graft product useful for treating a fistula having a primary opening in a wall of the alimentary canal and a fistula tract, the medical graft product comprising:

5 a biocompatible graft body configured to block at least the primary opening of the fistula, said graft body comprising a capping member and an elongate plug member having a proximal and distal end with a lumen extending therethrough, said capping member extending from the distal end of said elongate plug member and configured to contact portions of the alimentary canal wall adjacent to the primary
10 opening, said elongate plug member being configured to extend into at least a portion of the fistula tract and including a plurality of passages, wherein the longitudinal axis of each passage runs through said lumen to allow communication between opposing sides of the exterior surface of said elongate plug member.

15 33. The medical graft product of claim 32, wherein said elongate plug member further comprises multiple surface protuberances extending out from its exterior surface.

20 34. The medical graft product of claim 32, wherein at least one of said capping member and said elongate plug member comprises an expandable element.

 35. The medical graft product of claim 32, wherein said capping member comprises an expandable element.

25 36. The medical graft product of claim 34, wherein said expandable element is self-expanding.

 37. The medical graft product of claim 34, wherein said expandable element comprises a foam material.

38. The medical graft product of claim 34, wherein said expandable element comprises a wire frame.

39. A graft product for treating a fistula, comprising:
5 a graft body configured to reside in a tract of the fistula;
a capping member configured to contact tissues adjacent an opening of the
fistula;
said capping member connected to an end region of said graft body; and
said capping member including a portion positionable along an exterior lateral
10 surface of said graft body.

40. A medical graft product, comprising:
a capping member;
an elongate graft body extending from said capping member;
15 said capping member including a portion positionable over an exterior lateral
surface of said elongate graft body; and
said capping member portion conformable to said exterior lateral surface of
said elongate graft body.

20 41. An apparatus for treating a fistula having at least an opening in a bodily
structure wall and a fistula tract extending from the opening, the apparatus
comprising:
a delivery device having a lumen communicating with a distal end
opening, the delivery device configured for passage through the fistula tract
25 and the opening; and
a medical graft device removably positioned in the delivery device
lumen, the medical graft device comprised of a biocompatible graft body
including a capping member and an elongate plug member, the capping
member configurable to a first condition permitting at least part of the capping
30 member to be positioned along an exterior lateral surface of the elongate plug

member when in the delivery device lumen, the elongate plug member extending from the capping member and effective to fill at least a portion of the fistula tract.

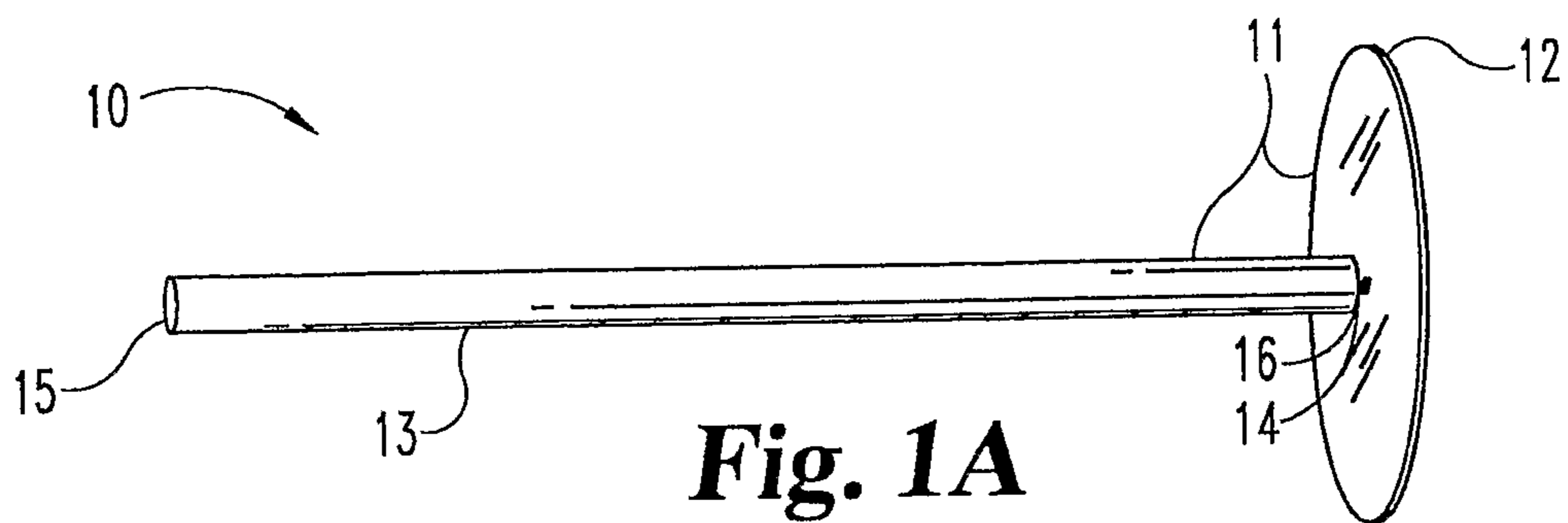

Fig. 1A



Fig. 1B

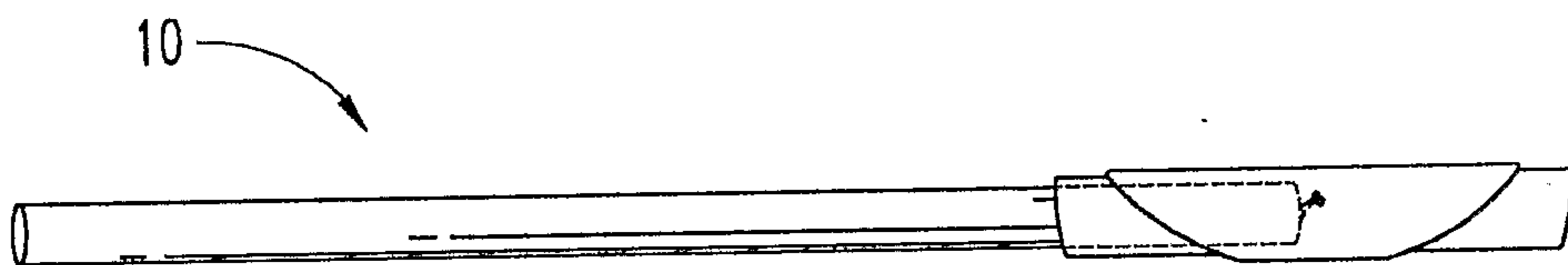

Fig. 1C

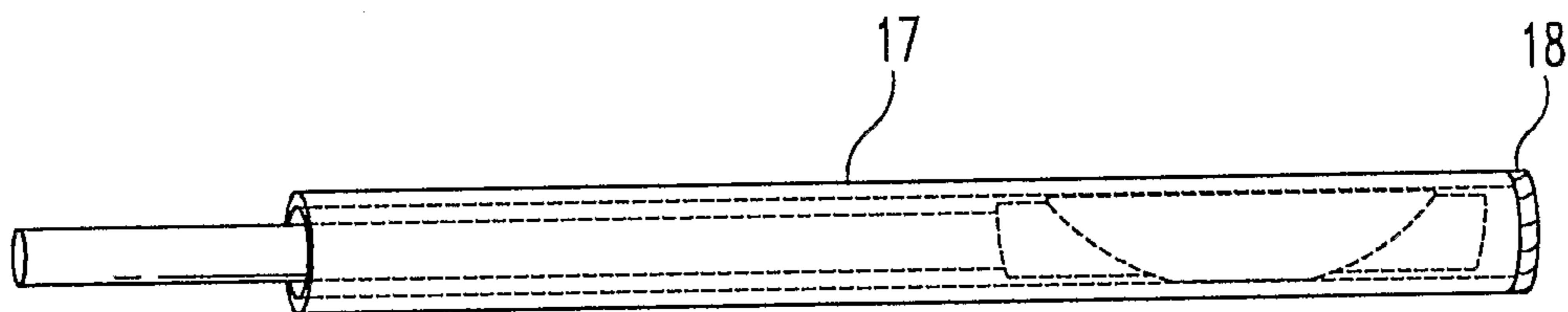

Fig. 1D

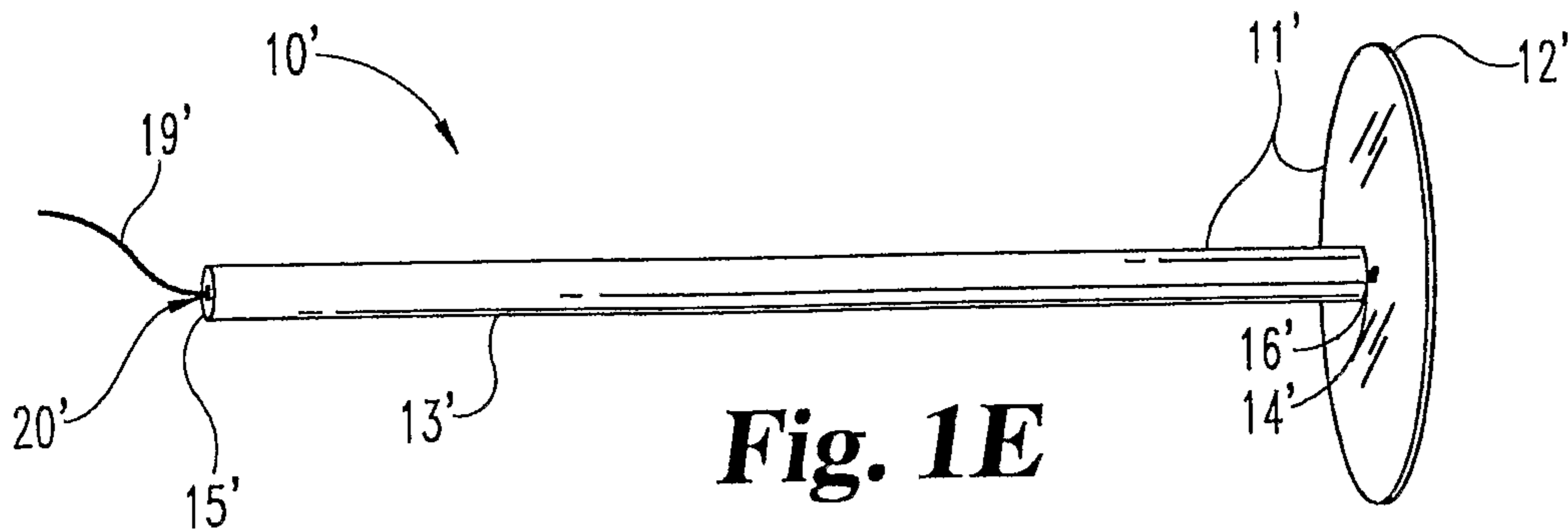

Fig. 1E

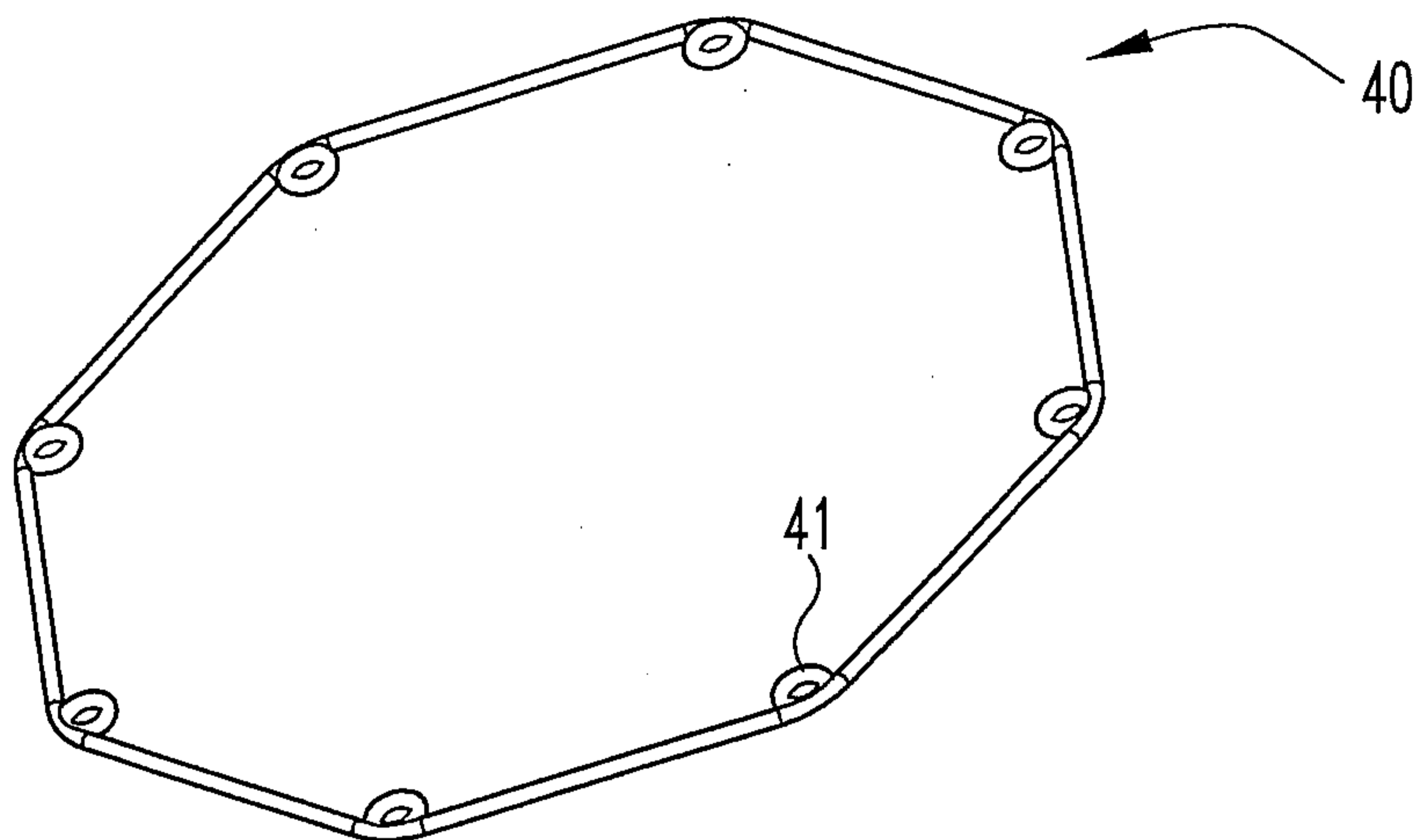

Fig. 2A

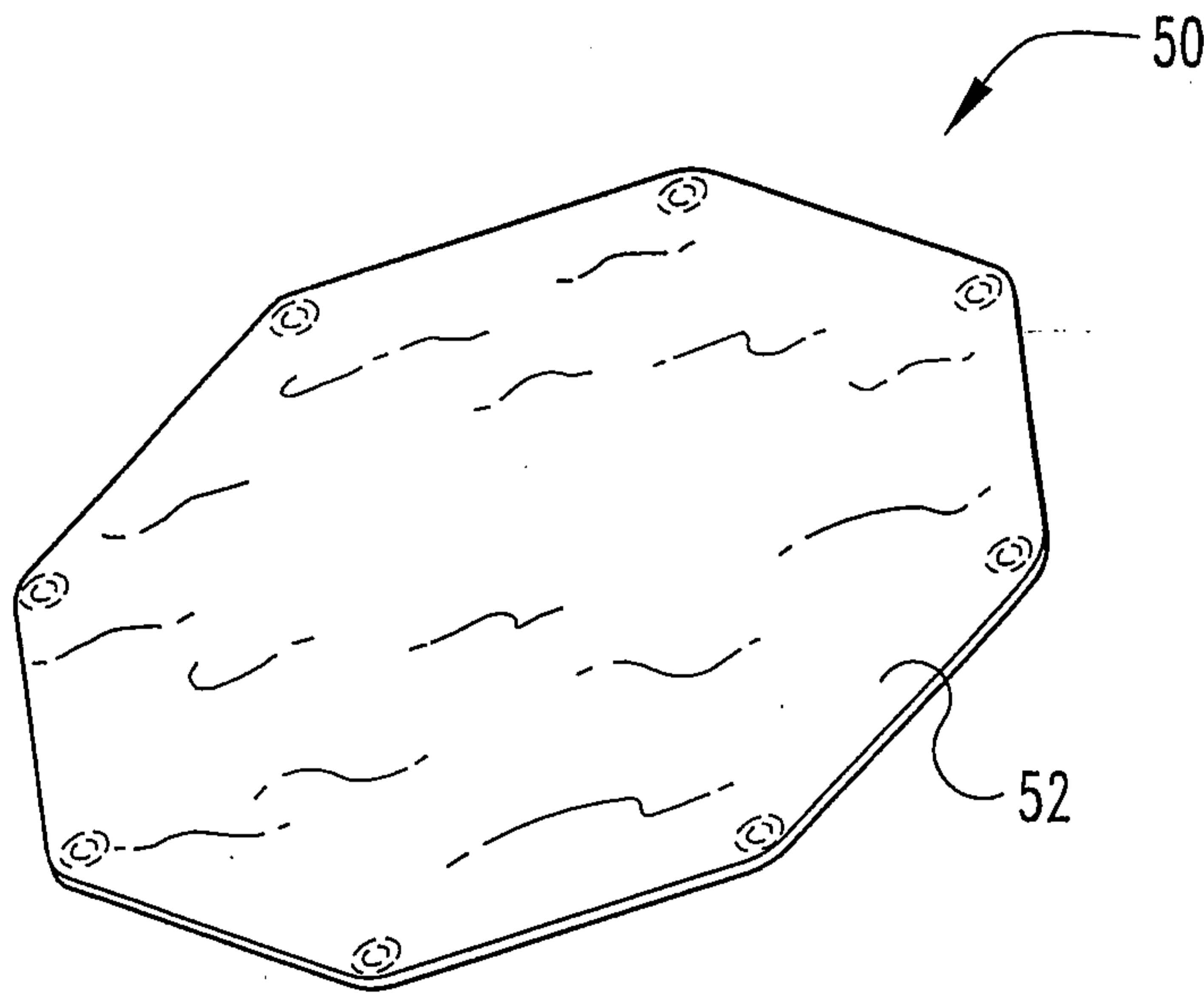

Fig. 2B

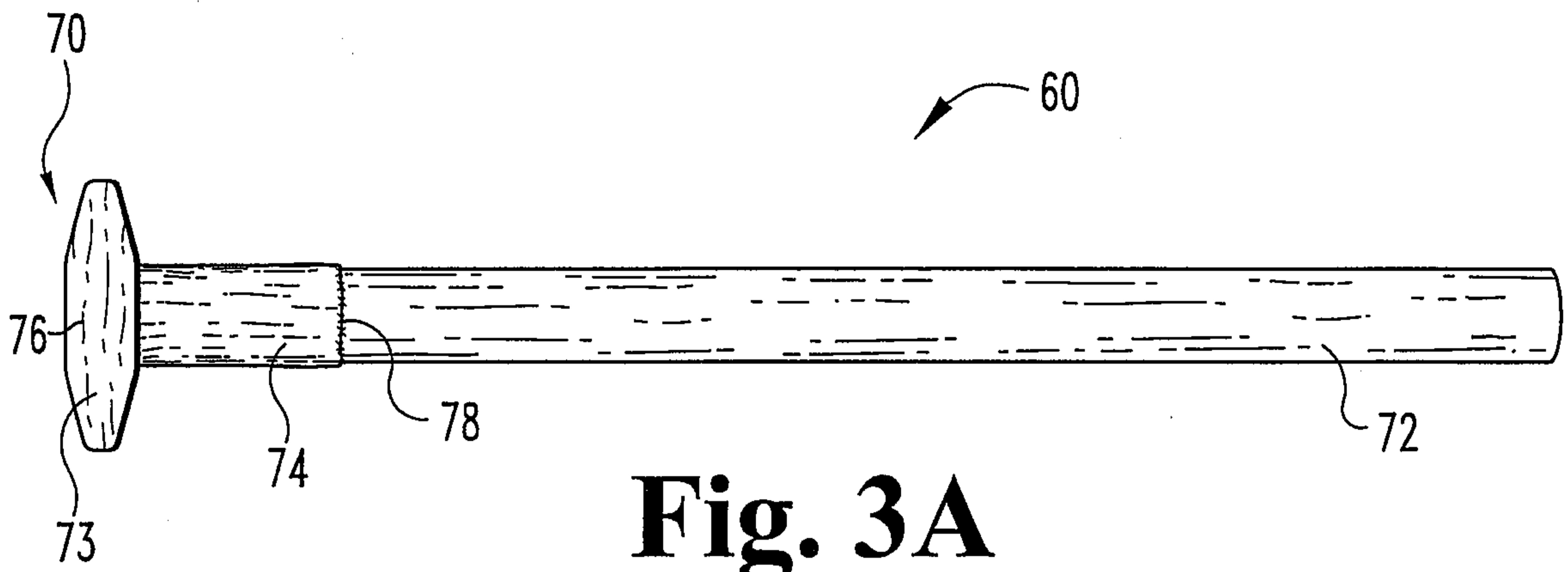

Fig. 3A

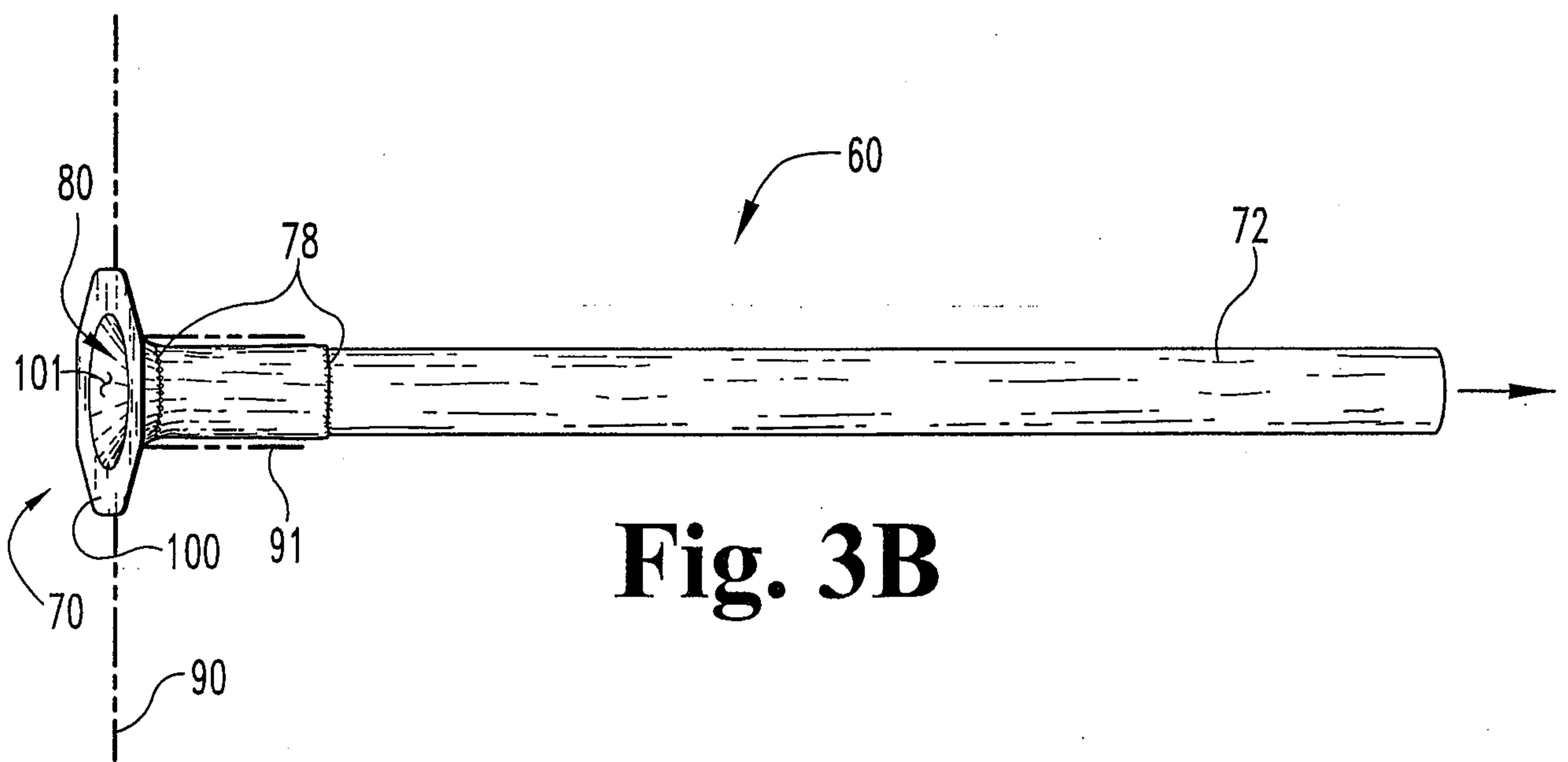

Fig. 3B

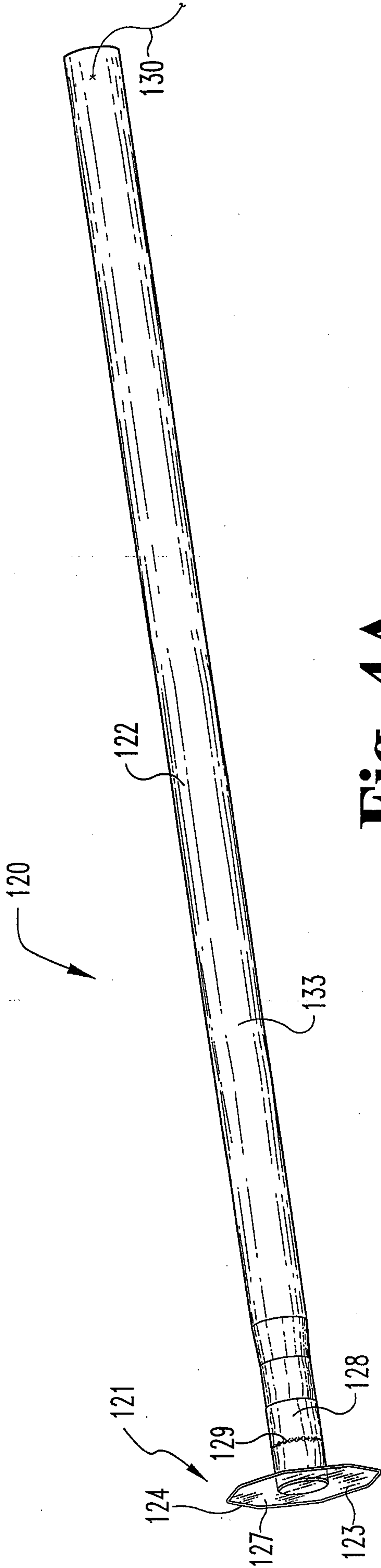

Fig. 4A

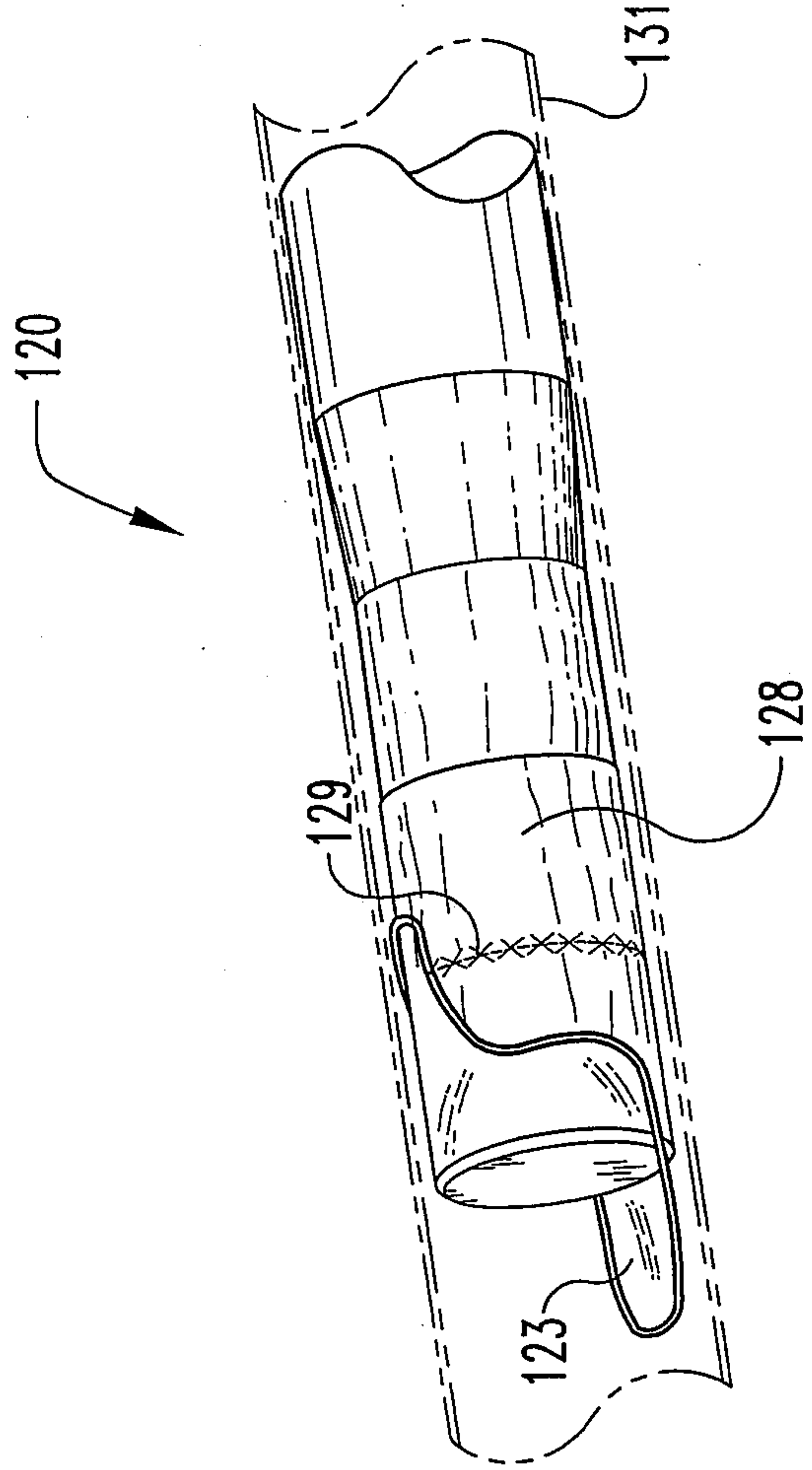

Fig. 4B

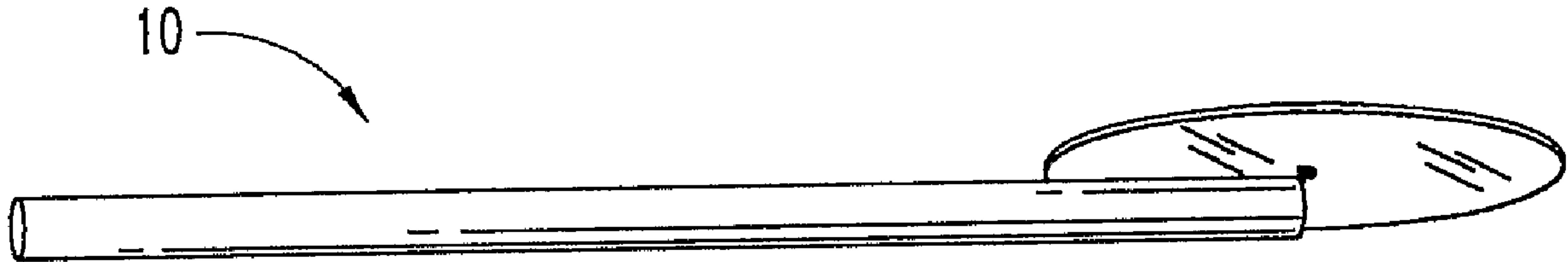

Fig. 1B