

July 16, 1963

LE ROY W. YARBOROUGH

3,097,406

ARTICLE HOLDER

Filed Aug. 24, 1960

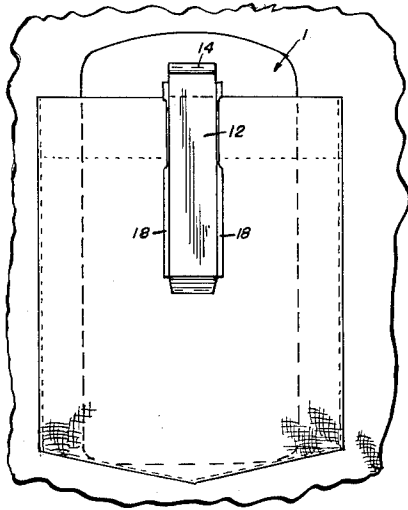

FIG. 1

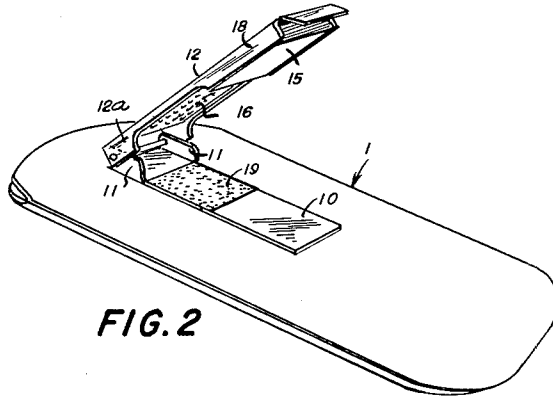

FIG. 2

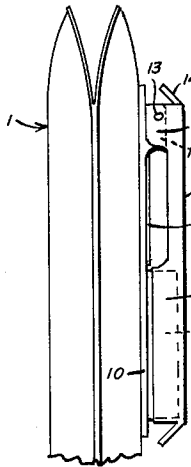

FIG. 3

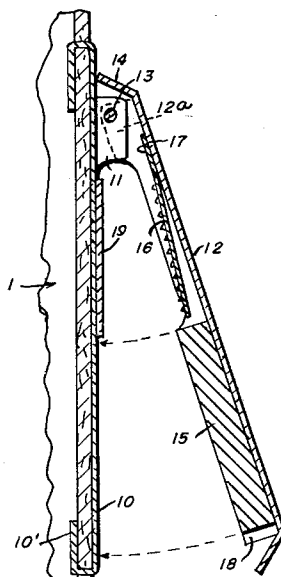

FIG. 4

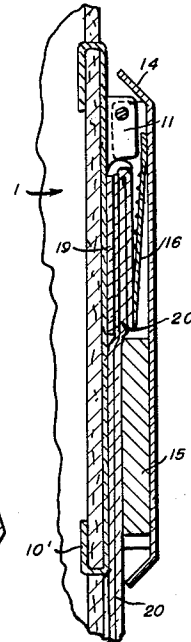

FIG. 5

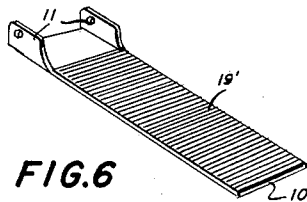

FIG. 6

INVENTOR

LeROY W. YARBOROUGH

BY *Frederick W. Turnbull*

ATTORNEY

1

3,097,406

ARTICLE HOLDER

Le Roy W. Yarborough, Mechanicsville,
Bucks County, Pa.

Filed Aug. 24, 1960, Ser. No. 51,563

4 Claims. (Cl. 24-3)

This invention relates to an article holder or carrier especially of the variety conventionally inserted in a pocket of a garment, and to a clip or clasp that holds said article holder or carrier against inadvertent displacement from the pocket.

Such article holders including glasses or spectacle cases and this type of article holder will be used to illustrate the present invention.

Glasses cases are known that frictionally grip a pair of glasses or spectacles inserted therein so that under ordinary conditions the glasses will remain in the case unless and until they are grasped and pulled out of the case. Such glasses cases, however, are frequently put into pockets in garments, especially shirt or "breast" pockets and often will fall out of such a pocket if the wearer bends down. Such loss of a glasses case is annoying, and if the glasses are in the case when it falls out of the pocket it can be expensive.

Glasses cases with spring clasps or spring clips are known; and, while they may retain the case in the pocket as desired, they are awkward to operate and are destructive of the garment by abrasion in mounting or unmounting.

It is a principal object of the present invention to provide a clip or clasp for an article holder, such as a glasses case, that does not use a spring in any form to force the clip into engagement with the fabric of the pocket, and which, when open, is not biased in any appreciable degree toward its closed position, and when closed requires substantial force to be applied to open it to release the fabric of the pocket edge.

A further object of the present invention is to provide a positive acting, inexpensive, clasp of attractive appearance for such items as article carriers, note books, or the like.

Other and further objects and advantages will appear from the following specification taken with the accompanying drawing in which like character of reference denotes similar parts in the several views and in which:

FIGURE 1 is a view showing the device in use;

FIGURE 2 is a perspective showing the clasp open;

FIGURE 3 is an elevation showing the clasp closed and not affixed to a pocket;

FIGURE 4 is a longitudinal section through the center of the clasp in open position;

FIGURE 5 is a section similar to FIGURE 4 but with the clasp closed on the pocket edge;

FIGURE 6 is a perspective view of a modified armature element.

The numeral 1 designates an article holder such as a glasses case but may, of course, be a holster for pencils and pens or for cigarettes or may be a note book, or the like. To the article carrier 1, in FIGURES 1 and 2, is secured an elongated magnetizable armature 10. This magnetizable armature may be secured to the article carrier by any conventional means such as adhesive, rivets, or, as shown, portions of the magnetizable armature forming tines 10' extending through or into the material of the article carrier and clinched. Stationary hinge portions 11 are provided at one end of the magnetizable armature 10 and a clamping plate 12 is provided with hinge portions 12a pivotally mounted on hinge portions 11 by pin 13. Stop means 14 may be provided on plate 12 to limit the swinging movement of plate 12 with respect to armature 10. Alternatively, of course, the stop could be provided

2

on plate 10 or in any other conventional manner. The hinge means shown is to be considered to be by way of example only and other hinge structures may be substituted that allow for free swinging operation between armature 10 and clamping plate 12 through the desired angle.

Clamping plate 12, at its end remote from pivot pin 13 is provided with a magnet 15 in a position to contact armature 10 when the clasp is closed when the article carrier is not clasped in a pocket, or the like. Any conventional means such as rivets, bolts, solder, or as illustrated, adhesive, may be used to mount magnet 15 on plate 12.

Mounted on the inner surface of clamping plate or bar 12 between hinge pin 13 and magnet 15 is gripping means 16 of resilient but deformable material presenting a roughened surface toward armature 10.

This element 16 is secured to plate 12 at one end, preferably, near hinge pin 13, as seen at 17. Where the element 16 is of metal element 17 may conveniently be solder.

It will be noted that thickness clearance is provided between armature 10 and plate 12 and lengthwise between the magnet 15 and the hinge. This thickness clearance is maintained at the one end by the hinge and at the other end by the magnet, or, when in use, by the magnet and the thickness of cloth between the magnet and armature.

Element 16 is adjustable by bending, and preferably extends to a position adjacent the plane of the magnet face.

The sides of plate 12 may be provided with skirt portions extending over the edges of magnet 15 as seen at 18 to present an attractive appearance. The portions of 18 as seen in FIGURE 3 are cut away to be of less depth between the magnet 15 and the hinge 13 to accommodate a relatively thick hem conventionally found at the top edge of the breast pocket of, say, a tweed jacket. Near the hinge 13 the skirt 18 may cooperate with hinge portions 11 that extend a sufficient distance from the pin 13 to form, with skirts 18, a stop means so that the edge of a pocket cannot jam the hinge to prevent the clasp from closing over the pocket edge.

There is also seen in FIGURES 2 and 4 a roughened surface forming gripping means at 19 (or 19' in FIGURE 6) is provided on the armature 10. In FIGURES 2 and 4 this roughened surface 19 is in the form of a sheet of abrasive material such as fine sand paper, and in FIGURE 6 this surface 19' is similar to a fine file surface on armature 10 itself. Where the sheet of abrasive material is used it is preferably limited to the portion of the armature 10 between the magnet and the hinge so as not to interfere with the magnetic flux between the magnet and armature when they are brought close together. Where the file surface is used, it may extend the entire length of the armature 10. The fineness of the abrasive, or the roughened, or file like, surface 19 or 19' is such as to give a high coefficient of friction. Too rough a surface has been found to have a slight tendency to raise the nap of the cloth. A fine surface, similar to 0 sand paper, upon release of the clasp and having no pressure against it will not pull the cloth.

Material 16 has a gripping surface much rougher than surfaces 19 or 19' and will positively engage the cloth, the prongs on element 16 presented toward armature 10 will penetrate the cloth slightly if pressed against it. The degree of such pressure can be adjusted, as pointed out above, by suitable bending of ancillary gripping element 16. This element, however, will not abraid the cloth of the pocket since, in applying the clasp, the surface of element 16 approaches the fabric of the pocket on an arc with pin 13 as its center, and the clasp cannot be moved with respect to the pocket edge until the plate 12, along

with the magnet 15 and element 16 has been lifted free of the material of the pocket edge.

In the known spring clasps whether pivoted and spring biased, or in the form of a spring clip the user has to fight the spring to open the clasp or clip and hold it open against the spring tension while either fastening or unfastening. Even if the surfaces of the clasp or clip are smooth the surface of the cloth of the garment is severely abraded because the operator does not fully open the clasp and cannot open a clip. Considerable force is expended in mounting or demounting a spring biased device in the pocket often requiring two hands, one to hold the clip or clasp sufficiently open to receive the cloth, and the other to hold the cloth. With the device of the present invention when the clasp is open as seen in FIGURES 2 and 4 the operator does not need to fight any tendency for the clasp to close since the magnet and armature are so remote from each other. The operator holding the device by grasping plate 12 and magnet 15, when the clasp is open, can insert the glasses case 1 into a pocket. Upon release of the plate 12 it falls toward the armature 10 where the increasing magnetic pull presses magnet 15, and element 16 against the outside of the garment pocket and the same pull presses armature 10 with its rough surface 19 or 19' against the inside of the pocket.

It will be noted that magnet 15, unlike a spring, is positioned at the end of plate 12 remote from pivot pin 13 so that, when the magnet approaches the armature in closing, the closing force is increased, whereas in spring operated devices the clamping stress becomes less as the clasp closes, and the wider the clasp is opened the greater strength is required to hold it open.

When the fabric 20 of the garment on which the device is to be used is excessively thick as on a tweed jacket as seen in FIGURE 5 it will at once be apparent that the ultimate circumferential pull between magnet 15 and armature 10 about pin 13 will be somewhat less than if it is used on a thin shirt pocket. It has been proven in use, however, that since the magnet is positioned at the end remote from hinge 13, and element 16 is close to hinge 13 even the reduced magnetic pull caused by the intervention of the thick or heavy material will effectively clasp the edge of the material.

The structure of the present invention may, with slight variation, be used for other purposes. As a supporter, for instance, for ladies stockings, using plastic for making element 10 except for an inserted armature element opposite the magnet 15 embedded in a plastic element 12, the hinge pin 13 passing through a loop at the end of a tape extending downwardly from the conventional belt or girdle. Clearly for such use the rough surfaces such as 19' must be such as not to "snag" the very fine texture of the stocking.

The above description and the accompanying drawings are directed to a specific example and are presented as illustrating a device incorporating the invention concepts of the present application and should not be viewed as in any way limiting the scope of the following claims, as

clearly various changes and modifications could be made without departing from the scope of the invention.

I claim:

1. In combination a glasses case and a clasp for use in retaining said glasses case in a pocket of a garment by gripping the edge of the pocket, said clasp comprising an elongated armature adapted to be secured to said glasses case in a position to extend from a position normally outside of the pocket in a direction generally normal to the edge of the pocket when the article is in the pocket, a hinge means mounted on the end of said armature normally lying outside of said pocket, an elongated clamping plate hinged thereon to overlie said armature and to be swingable toward and away from said armature and from the fabric of a pocket inserted between said armature and said clamping plate, stop means to limit the swing of said clamping plate away from said armature, magnet means adapted to normally pull said clamping plate toward said armature, said magnet means being mounted on said clamping plate at its end remote from said hinge means, and a resilient gripping element of plate material secured to said clamping plate adjacent said hinge and bendable so as to provide for adjustment of the position of the face of said gripping element with respect to said clamping plate and presenting a gripping surface toward said armature between said magnet means and said hinge means.

2. The device of claim 1 in which the surface of said armature is provided with a roughened surface to provide a frictional grip between said armature and the pocket of the garment.

3. The device of claim 2 in which said roughened surface is limited to the portion of said armature opposite to said resilient gripping element.

4. The clasp of claim 1 in which clearance space is provided between said first and said second elongated members extending from the magnet element toward said hinge means to receive the folded edge of the article of clothing.

References Cited in the file of this patent

UNITED STATES PATENTS

287,460	Pattee et al. -----	Oct. 30, 1883
571,373	Johnston -----	Nov. 17, 1896
1,003,711	Cunningham -----	Sept. 19, 1911
1,061,820	Colbert -----	May 13, 1913
1,435,869	Mount -----	Nov. 14, 1922
2,268,116	Gordon -----	Dec. 30, 1941
2,448,611	Martin -----	Sept. 7, 1948
2,453,488	Bowen -----	Nov. 9, 1948
2,551,515	Tschirf -----	May 1, 1951
2,592,395	Cummings -----	Apr. 8, 1952
2,986,835	Ordinetz et al. -----	June 6, 1961

FOREIGN PATENTS

752,813	France -----	July 14, 1933
89,101	Switzerland -----	Apr. 16, 1921