

(19)



(11)

**EP 3 141 827 B1**

(12)

**EUROPEAN PATENT SPECIFICATION**

(45) Date of publication and mention of the grant of the patent:  
**16.09.2020 Bulletin 2020/38**

(51) Int Cl.:  
**F24F 1/50** <sup>(2011.01)</sup>      **F24F 1/16** <sup>(2011.01)</sup>  
**F24F 1/18** <sup>(2011.01)</sup>

(21) Application number: **14891486.4**

(86) International application number:  
**PCT/JP2014/062482**

(22) Date of filing: **09.05.2014**

(87) International publication number:  
**WO 2015/170402 (12.11.2015 Gazette 2015/45)**

(54) **AIR-CONDITIONING UNIT**

KLIMAANLAGENEINHEIT

UNITÉ DE CLIMATISATION

(84) Designated Contracting States:  
**AL AT BE BG CH CY CZ DE DK EE ES FI FR GB GR HR HU IE IS IT LI LT LU LV MC MK MT NL NO PL PT RO RS SE SI SK SM TR**

• **TADOKORO, Takahide**  
**Tokyo 100-8310 (JP)**

(43) Date of publication of application:  
**15.03.2017 Bulletin 2017/11**

(74) Representative: **Mewburn Ellis LLP**  
**Aurora Building**  
**Counterslip**  
**Bristol BS1 6BX (GB)**

(73) Proprietor: **Mitsubishi Electric Corporation**  
**Chiyoda-ku**  
**Tokyo 100-8310 (JP)**

(56) References cited:  
**WO-A1-2013/183710**      **WO-A1-2014/024221**  
**JP-A- 2003 254 565**      **JP-A- 2003 254 565**  
**JP-A- 2003 279 076**      **JP-A- 2003 279 076**  
**JP-A- 2006 071 162**

(72) Inventors:  
• **KONO, Atsushi**  
**Tokyo 100-8310 (JP)**

Note: Within nine months of the publication of the mention of the grant of the European patent in the European Patent Bulletin, any person may give notice to the European Patent Office of opposition to that patent, in accordance with the Implementing Regulations. Notice of opposition shall not be deemed to have been filed until the opposition fee has been paid. (Art. 99(1) European Patent Convention).

**EP 3 141 827 B1**

**Description**

## Technical Field

**[0001]** The present invention relates to an air-conditioning unit configured to cause an air flow generated by rotation of a fan to pass through a heat exchanger.

## Background Art

**[0002]** In a top-blow type outdoor unit of an air conditioner, an air flow generated by rotation of a fan is caused to pass through a heat exchanger, thereby allowing heat exchange to occur between outside air and refrigerant. When there is unevenness in velocity distribution of the air flow (air velocity distribution) passing through the heat exchanger, heat-exchange efficiency in the heat exchanger is degraded.

**[0003]** Hitherto, in order to reduce the unevenness in the air velocity distribution in the heat exchanger, there has been known a top-blow type outdoor unit of an air conditioner, in which a fin pitch of a heat exchanger arranged at a lower level far apart from the fan is set to be larger than a fin pitch of a heat exchanger arranged at an upper level close to the fan, to thereby cause air flow resistance in the heat exchanger at the lower level to be smaller than air flow resistance in the heat exchanger at the upper level (see Patent Literatures 1 to 3).

**[0004]** Further, hitherto, there has also been proposed a top-blow type outdoor unit of an air conditioner, in which a pipe diameter of the heat exchanger at the lower level is set to be smaller than a pipe diameter of the heat exchanger at the upper level (see Patent Literatures 1 and 4) or in which fin shapes or the number of rows of fins of the heat exchangers at the upper level and those at the lower level are set to be different from each other (see Patent Literatures 2 and 4), to thereby cause the air flow resistance of the heat exchanger at the lower level to be smaller than the air flow resistance of the heat exchanger at the upper level. JP2003254565 proposes an outdoor machine for an air conditioner having a heat exchanger with a U-shaped cross section. JP2003279076 proposes an outdoor unit of an air conditioner having a box-shaped body and furnished with a compressor. WO 2014/024221 proposes a heat exchanger with a plurality of fins.

## Citation List

## Patent Literature

**[0005]**

- [PTL 1] JP 2006-153332 A
- [PTL 2] JP 2006-71162 A
- [PTL 3] JP 4-116384 A
- [PTL 4] JP 2005-249255 A

## Summary of Invention

## Technical Problem

**[0006]** In the top-blow type outdoor unit of the air conditioner, when the unit is viewed along an axis of the fan, there are present an area in which the heat exchanger is arranged and an area in which the heat exchanger is not arranged in a rotation direction of the fan. In the area in which the heat exchanger is not arranged, a wall panel for blocking passage of air is arranged. Thus, in the top-blow type outdoor unit of the air conditioner, when the fan rotates, the air flow is supplied into the unit from the area in which the heat exchanger is arranged. However, the air flow is not supplied into the unit from the area in which the heat exchanger is not arranged. As a result, in the top-blow type outdoor unit of the air conditioner, unevenness in the air velocity distribution occurs in the rotation direction of the fan. When there are unevenness in the air velocity distribution and occurrence of air flow turbulence around the fan, fluctuation of the air flow around blades of the fan become stronger during movement of the blades of the fan, with the result that vibration and energy loss are increased.

**[0007]** In the related-art top-blow type outdoor unit of the air conditioner, when the unit is viewed along the axis of the fan, the area of the heat exchanger at the lower level is equal to the area of the heat exchanger at the upper level or larger than the area of the heat exchanger at the upper level. Thus, the unevenness in the air velocity distribution in the rotation direction of the fan becomes larger even in a region close to the fan. Thus, in the related-art top-blow type outdoor unit of the air conditioner, noise due to the vibration generated during the rotation of the fan and the energy loss increases. Meanwhile, when the area of the heat exchanger arranged on a side surface of the unit is extended in the rotation direction of the fan, the unevenness in the air velocity distribution in the rotation direction of the fan decreases. However, maintenance work for devices inside the unit becomes more difficult to perform.

**[0008]** The present invention has been made to solve the problem described above, and an object of the present invention is to provide an air-conditioning unit capable of achieving reduction of noise and improvement in energy efficiency and facilitating maintenance work.

## Solution to Problem

**[0009]** An air-conditioning unit according to claim 1 is provided.

## Advantageous Effects of Invention

**[0010]** According to the air-conditioning unit of the present invention, the unevenness in the air velocity distribution in the rotation direction of the fan can be suppressed around the fan, thereby being capable of achiev-

ing the reduction of noise and the improvement in the energy efficiency. Further, an area in which the heat exchange section is absent can be secured, thereby being capable of facilitating maintenance work.

#### Brief Description of Drawings

#### [0011]

[FIG. 1] FIG. 1 is a perspective view for illustrating an air-conditioning unit according to a first embodiment of the present invention.

[FIG. 2] FIG. 2 is a perspective view for illustrating an air blower, a heat exchanger, and a part of a casing.

[FIG. 3] FIG. 3 is a top view for illustrating an outdoor unit as viewed along an axial direction of a fan illustrated in FIG. 2.

[FIG. 4] FIG. 4 is a perspective view for illustrating the outdoor unit for illustrating a peripheral length of each of heat exchange sections illustrated in FIG. 2.

[FIG. 5] FIG. 5 is a perspective view for illustrating the outdoor unit for illustrating an air velocity distribution in each of the heat exchange sections illustrated in FIG. 2.

[FIG. 6] FIG. 6 is a sectional view taken along the plane VI of FIG. 5.

[FIG. 7] FIG. 7 is a sectional view taken along the plane VII of FIG. 5.

[FIG. 8] FIG. 8 is a schematic sectional view taken along the plane VIII of FIG. 2.

[FIG. 9] FIG. 9 is a perspective view for illustrating relevant parts of an outdoor unit according to a second embodiment of the present invention.

[FIG. 10] FIG. 10 is a sectional view taken along the plane X of FIG. 9.

[FIG. 11] FIG. 11 is a sectional view taken along the plane XI of FIG. 9.

[FIG. 12] FIG. 12 is a perspective view for illustrating relevant parts of an outdoor unit according to a third embodiment of the present invention.

[FIG. 13] FIG. 13 is a schematic sectional view taken along the plane XIII of FIG. 12.

[FIG. 14] FIG. 14 is a perspective view for illustrating relevant parts of an outdoor unit according to a fourth embodiment of the present invention.

[FIG. 15] FIG. 15 is a schematic view for illustrating each of fins in a heat exchange section illustrated in FIG. 14.

[FIG. 16] FIG. 16 is a perspective view for illustrating relevant parts of an outdoor unit according to a fifth embodiment of the present invention.

[FIG. 17] FIG. 17 is a sectional view taken along the plane XVII of FIG. 16.

[FIG. 18] FIG. 18 is a sectional view for illustrating another example of a heat exchange panel of the outdoor unit according to the fifth embodiment of the present invention.

[FIG. 19] FIG. 19 is a sectional view for illustrating another example of the heat exchange panel of the outdoor unit according to the fifth embodiment of the present invention.

[FIG. 20] FIG. 20 is a sectional view for illustrating another example of the heat exchange panel of the outdoor unit according to the fifth embodiment of the present invention.

[FIG. 21] FIG. 21 is a perspective view for illustrating relevant parts of an outdoor unit according to a sixth embodiment of the present invention.

[FIG. 22] FIG. 22 is a sectional view taken along the plane XXII of FIG. 21.

[FIG. 23] FIG. 23 is a sectional view for illustrating another example of a heat exchange panel of the outdoor unit according to the sixth embodiment of the present invention.

[FIG. 24] FIG. 24 is a perspective view for illustrating relevant parts of an outdoor unit according to a seventh embodiment of the present invention.

[FIG. 25] FIG. 25 is a perspective view for illustrating the outdoor unit for illustrating a peripheral length of each of the heat exchange sections illustrated in FIG. 24.

[FIG. 26] FIG. 26 is a perspective view for illustrating an outdoor unit according to an eighth embodiment of the present invention.

[FIG. 27] FIG. 27 is a schematic sectional view taken along the plane XXVII of FIG. 26.

[FIG. 28] FIG. 28 is a perspective view for illustrating an outdoor unit according to a ninth embodiment of the present invention.

[FIG. 29] FIG. 29 is a schematic sectional view taken along the plane XXIX of FIG. 28.

#### Description of Embodiments

[0012] Now, preferred embodiments of the present invention are described with reference to the accompanying drawings.

#### First Embodiment

[0013] FIG. 1 is a perspective view for illustrating an air-conditioning unit according to a first embodiment of the present invention. In FIG. 1, an air conditioner forms a refrigeration cycle by circulating refrigerant between an indoor unit and an outdoor unit (air-conditioning unit) 1. The outdoor unit 1 includes a casing 2 and an in-unit device 3 accommodated within the casing 2.

[0014] The casing 2 includes a bottom plate 21, a top plate 22 positioned above the bottom plate 21, a plurality of supporting columns 23 fixed to an outer peripheral portion of the bottom plate 21 so as to be spaced away from each other and configured to support the top plate 22, and a plurality of side panels 24 forming side surfaces of the casing 2 between the bottom plate 21 and the top plate 22. In this example, a shape of each of the bottom

plate 21 and the top plate 22 is approximately quadrangular, and the four supporting columns 23 are fixed to four corners of each of the bottom plate 21 and the top plate 22. Thus, in this example, the side surfaces of the casing 2 are formed by the four side panels 24.

**[0015]** The in-unit device 3 includes an air blower 31, a refrigeration cycle device 32 allowing a flow of the refrigerant, and a drive control device (not shown) configured to control drive of the air blower 31 and the refrigeration cycle device 32. The refrigeration cycle device 32 includes a heat exchanger 321, a compressor, an electromagnetic valve, and heat transfer pipes (refrigerant pipes), which are elements for forming the refrigeration cycle.

**[0016]** FIG. 2 is a perspective view for illustrating the air blower 31, the heat exchanger 321, and a part of the casing 2. The air blower 31 includes a fan 311 which is rotatable about an axis A extending along a height direction of the outdoor unit 1, and a fan motor (drive unit) coupled to the fan 311 and configured to generate a driving force for rotating the fan 311.

**[0017]** The fan 311 is arranged so as to be shifted upward relative to the refrigeration cycle device 32 in a direction along the axis A (axial direction of the fan 311). The fan 311 is a propeller fan including a boss 313 arranged coaxially with the axis A and a plurality of (four in this example) of blades 314 provided on an outer peripheral portion of the boss 313. The blades 312 are arranged so as to be spaced away from each other in a peripheral direction of the boss 313. The fan motor 312 is arranged below the fan 311.

**[0018]** For the heat exchanger 321, a plurality of (two in this example) of regions 41 and 42 arrayed in the direction along the axis A are set. In this example, the region 41 and the region 42 are arrayed in the stated order in a direction away from the fan 311. The heat exchanger 321 is segmented into a plurality of heat exchange sections 321a and 321b that are present in the regions 41 and 42, respectively. As a result, in the heat exchanger 321, the heat exchange section 321a present in the region 41 is arranged at a position closer to the fan 311 than the heat exchange section 321b present in the region 42. In this example, a dimension of the region 41 is larger than a dimension of the region 42 in the direction along the axis A.

**[0019]** FIG. 3 is a top view for illustrating the outdoor unit 1 as viewed along an axial direction of the fan 311 illustrated in FIG. 2. Further, FIG. 4 is a perspective view for illustrating the outdoor unit 1 for illustrating a peripheral length of each of the heat exchange sections 321a and 321b illustrated in FIG. 2. The heat exchanger 321 is arranged around the axis A. Further, the heat exchanger 321 is arranged on an imaginary setting plane B that surrounds an entire periphery of the axis A. The imaginary setting plane B is a plane parallel to the axis A. Further, when the heat exchanger 321 is viewed in the direction along the axis A (axial direction of the fan 311), the imaginary setting plane B may be seen as an endless

surrounding line that surrounds the axis A (FIG. 3). The imaginary setting plane B includes a plurality of plane sections B1 to B4 respectively overlap with sides of a polygon surrounding the entire periphery of the axis A. In this example, the four plane sections B1 to B4 of the imaginary setting plane B are positioned on sides of the quadrangle, which correspond to the four side panels 24 of the casing 2. Some devices (for example, the compressor, the electromagnetic valve, and the like) other than the heat exchanger 321 included in the refrigeration cycle device 32 are arranged on an inner side of the imaginary setting plane B.

**[0020]** Assuming that a direction along the imaginary setting plane B on a plane perpendicular to the axis A is a peripheral direction of the imaginary setting plane B, between a length La of the heat exchange section 321a and a length Lb of the heat exchange section 321b along the peripheral direction of the imaginary setting plane B, a length of the heat exchange section present in a region closer to the fan 311 is longer, as illustrated in FIG. 4. Specifically, when the heat exchange section 321 is viewed in the direction along the axis A, the length La of the heat exchange section 321a present in the region 41 is longer than the length of the heat exchange section 321b present in the region 42 farther away from the fan 311 than the region 41 in the direction along the imaginary setting plane B (La>Lb). In this example, when the heat exchanger 321 is viewed in the direction along the axis A, a position of one end portion of the heat exchange section 321a and a position of one end portion of the heat exchange section 321b coincide with each other in the direction along the imaginary setting plane B, whereas a position of another end portion of the heat exchange section 321a and a position of another end portion of the heat exchange section 321b are different from each other.

**[0021]** Each of the heat exchange sections 321a and 321b includes a plurality of the heat transfer pipes (refrigerant pipes) arranged so as to be spaced away from each other, and a plurality of fins for radiation provided in each of the heat transfer pipes and arranged so as to be spaced away from each other in a length direction of the heat transfer pipe. In each of the heat exchange sections 321a and 321b, heat exchange occurs between the refrigerant and outside air while the refrigerant sequentially passes through the heat transfer pipes. Each of the heat exchange sections 321a and 321b may include a plurality of heat transfer pipes arranged so as to be spaced away from each other and a plurality of fins arranged in a wave-like form between the heat transfer pipes.

**[0022]** The side panels 24 of the casing 2 surround both of the axis A and the imaginary setting plane B. In the regions 41 and 42, there are formed areas in which the heat exchange sections 321a and 321b are present and areas in which the heat exchange sections 321a and 321b are absent in a rotation direction C of the fan 311 (FIG. 3). In each of the side panels 24 of the casing 2, a

section that covers the areas in which the heat exchange sections 321a and 321b are present is formed as a panel air passage section 241 (FIG. 1) configured to allow passage of the air (air flow), whereas a section that covers the areas in which the heat exchange sections 321a and 321b are absent is formed as a panel shielding section 242 configured to block passage of the air (air flow). Thus, at least any one of the side panels 24 has the panel shielding section 242. The panel shielding section 242 covers the areas in which the heat exchange sections 321a and 321b are absent. The panel air passage section 241 has a grating 243 provided in an opening as illustrated in FIG. 1.

**[0023]** The area in which the heat exchanger 321 is absent in the rotation direction of the fan 311 is larger in the region of the regions 41 and 42 farther away from the fan 311 in the direction along the axis A. Some devices (for example, the compressor, the electromagnetic valve, and the like) arranged on an inner side of the imaginary setting plane B are arranged in the region 42 farther away from the fan 311 than the region 41 closest to the fan 311.

**[0024]** In the center of the top panel 22, an air outlet 221 is formed as illustrated in FIG. 1. Further, a bellmouth 222 that surrounds the air outlet 221 is fixed to an upper surface of the top plate 22. The fan 311 is arranged on an inner side of the bellmouth 222. A grid 223 that covers an opening of the bellmouth 222 is provided on the bellmouth 222.

**[0025]** In the outdoor unit 1, when the fan 311 rotates, there is generated air (air flow) that enters into the casing 2 from side surfaces of the casing 2 and leaves from inside of the casing 2 to outside of the casing 2 through the air outlet 221. Thus, the outdoor unit 1 is constructed as a so-called top-blow type outdoor unit. The air generated by the rotation of the fan 311 passes through the panel air passage section 241 of each of the side panels 24 to move into the casing 2. After passing through the heat exchanger 321, the air leaves to outside of the casing 2 from the air outlet 221. In the heat exchanger 321, the air from the panel air passage sections 241 of the side panels 24 passes through the heat exchanger 321 to allow heat exchange to occur between the refrigerant passing through the heat transfer pipes and the outside air. In the area of the side panel 24 in which the panel shielding section 242 is arranged, inflow of the air from the side surfaces of the casing 2 into the casing 2 is blocked.

**[0026]** FIG. 5 is a perspective view for illustrating the outdoor unit 1 for illustrating an air velocity distribution in each of the heat exchange sections 321a and 321b illustrated in FIG. 2. Further, FIG. 6 is a sectional view taken along the plane VI of FIG. 5, and FIG. 7 is a sectional view taken along the plane VII of FIG. 5. An air flow Va passing through the heat exchange section 321a present in the region 41 of the regions 41 and 42 closer to the fan 311 flows into the casing 2 from an area larger in the rotation direction of the fan 311 than a region from which an air flow Vb passing through the heat exchange section

321b present in the region 42 farther away from the fan 311 than the region 41 flows thereinto. Therefore, unevenness in an air velocity distribution (suction air velocity distribution) sucked into the casing 2 from the side surfaces of the casing 2 becomes smaller in the region 41 closer to the fan 311 than in the region 42 farther away from the fan 311. As a result, when the fan 311 rotates, the unevenness in the air velocity distribution in the rotation direction of the fan 311 is reduced around the fan 311, thereby reducing fluctuation of the air flow generated by the blades 314.

**[0027]** FIG. 8 is a schematic sectional view taken along the plane VIII of FIG. 2. In FIG. 8, there are shown air velocity distributions at three positions on the plane VIII of FIG. 2, at which distances from the fan 311 are different in the direction along the axis A. Further, in FIG. 8, among the three positions for which the air velocity distributions are shown, the position closest to the fan 311 and the position second closest to the fan 311 are positioned in the region 41, whereas the position most away from the fan 311 is positioned in the region 42.

**[0028]** Among the above-mentioned positions, an air velocity distribution V1 at the position most away from the fan 311 is formed by the air flow Vb having passed through the heat exchange section 321b that is present only on one side in the casing 2 illustrated in FIG. 8, and hence there is provided an uneven air velocity distribution with a higher speed on a side close to the heat exchange section 321b. However, the air flow Vb having passed through the heat exchange section 321b flows upward to the fan 311 in the casing 2 to be mixed with the air flow Va having passed through the heat exchange section 321a present on both sides in the casing 2 illustrated in FIG. 8. As a result, the unevenness in the air velocity distribution is reduced more significantly in a direction closer to the fan 311 in the order of the position most away from the fan 311 (air velocity distribution V1), the position second closest to the fan 311 (air velocity distribution V2), and the position closest to the fan 311 (air velocity distribution V3), as illustrated in FIG. 8. Specifically, the air flow Vb flowing toward the fan 311 in the casing 2 is mixed with the air flow Va flowing from the heat exchange section 321a, thereby reducing the unevenness in the air velocity distribution. As a result, the air velocity distribution V3 at the position closest to the fan 311 becomes an air velocity distribution equalized in the rotation direction of the fan 311.

**[0029]** In the outdoor unit 1 described above, the heat exchanger 321 is segmented into the plurality of heat exchange sections 321a and 321b that are respectively present in the plurality of regions 41 and 42 arrayed in the axial direction of the fan 311. Between the length La of the heat exchange section 321a and the length Lb of the heat exchange section 321b in the peripheral direction of the imaginary setting plane B, a length of the heat exchange section present in the region closer to the fan 311 is longer. Therefore, the unevenness in the air velocity distribution in the rotation direction of the fan 311

can be reduced around the fan 311. As a result, the air flow fluctuation at the blades 314 during the rotation of the fan 311 can be reduced, thereby achieving reduction of noise generated by the rotation of the fan 311. Further, an energy loss of the fan 311 can also be suppressed, thereby being capable of achieving improvement in energy efficiency of the fan 311. Further, the area in which the heat exchanger 321 is absent in the rotation direction of the fan 311 can be secured to be large in the region 42 of the regions 41 and 42, which is farther away from the fan 311, thereby being capable of facilitating maintenance work for the devices inside the casing 2. Further, the devices inside the casing 2 are arranged in the region 42 farther away from the fan 311 than the region 41, thereby being capable of more reliably securing an installation space for the devices inside the casing 2, and reducing influence of the devices inside the casing 2 on the unevenness in the air velocity distribution around the fan 311.

#### Second Embodiment

**[0030]** FIG. 9 is a perspective view for illustrating relevant parts of the outdoor unit 1 according to a second embodiment of the present invention. Further, FIG. 10 is a sectional view taken along the plane X of FIG. 9, and FIG. 11 is a sectional view taken along the plane XI of FIG. 9. The heat exchange section 321a present in the region 41 of the regions 41 and 42 closest to the fan 311 is arranged along all of the plurality of (four in this example) plane sections B1 to B4 included in the imaginary setting plane B. Specifically, when the outdoor unit 1 is viewed in the direction along the axis A, the heat exchange section 321a is arranged along all of sides of a polygon (quadrangle in this example) that surrounds the axis A.

**[0031]** The heat exchange section 321a is arranged continuously along the peripheral direction of the imaginary setting plane B from one end portion of the heat exchange section 321a to reach another end portion of the heat exchange section 321a, as illustrated in FIG. 10. A space (specifically, an area of the region 41 in which the heat exchange section 321a is absent in the rotation direction of the fan 311) between the one end portion and the another end portion of the heat exchange section 321a in the peripheral direction of the imaginary setting plane B is set to be as narrow as possible.

**[0032]** The heat exchange section 321b that is present in the region 42 farther away from the fan 311 than the region 41 is arranged along the remaining plane sections B1 to B3 excluding any one of the plane sections B1 to B4 of the imaginary setting plane B. Similarly to the heat exchange section 321a, the heat exchange section 321b is arranged continuously along the peripheral direction of the imaginary setting plane B from one end portion of the heat exchange section 321b to reach another end portion of the heat exchange section 321b as illustrated in FIG. 11. In this example, when the outdoor unit 1 is

viewed along the axial direction of the fan 311, the position of the one end portion of the heat exchange section 321a and the position of the one end portion of the heat exchange section 321b coincide with each other, whereas the position of the another end portion of the heat exchange section 321a and the position of the another end portion of the heat exchange section 321b are different from each other.

**[0033]** When the heat exchanger 321 is viewed in the peripheral direction of the imaginary setting plane B, a length of the heat exchange section 321a is longer than a length of the heat exchange section 321b. Therefore, the air flow Va passing through the heat exchange section 321a closer to the fan 311 flows into the casing 2 from a larger area in the rotation direction of the fan 311 than an area from which the air flow Vb passing through the heat exchange section 321b farther away from the fan 311 than the heat exchange section 321a flows thereinto. Other configurations are the same as those of the first embodiment.

**[0034]** In the outdoor unit 1 described above, when the imaginary setting plane B is viewed in the direction along the axis A, the plurality of plane sections B1 to B4 respectively overlapping with the sides of the polygon surrounding the axis A are included in the imaginary setting plane B. The heat exchange section 321a that is present in the region 41 of the regions 41 and 42 closest to the fan 311 is arranged along all of the plane sections B1 to B4. Thus, in the region 41 of the regions 41 and 42 closest to the fan 311, unevenness in the area of the heat exchange section 321a can be reduced in the rotation direction of the fan 311. As a result, the reduction of the unevenness in the air velocity distribution in the rotation direction of the fan 311 can be further achieved around the fan 311. Thus, the suppression of noise during the rotation of the fan 311 and the improvement in the energy efficiency can be further achieved.

#### Third Embodiment

**[0035]** FIG. 12 is a perspective view for illustrating relevant parts of the outdoor unit 1 according to a third embodiment of the present invention. FIG. 13 is a schematic sectional view taken along the plane XIII of FIG. 12. The heat exchange section 321a that is present in the region 41 of the regions 41 and 42 closest to the fan 311 includes a plurality of heat exchange panels 322 that are arrayed so as to overlap with each other with the axis A being set on an inner side. Air flow resistance (pressure loss)  $\Delta P$  [Pa] of the air flow Va passing through the heat exchange section 321a present in the region 41 closest to the fan 311 is equalized in the peripheral direction of the imaginary setting plane B through adjustment of the number of rows of the heat exchange panels 322 in the heat exchange section 321a in the peripheral direction of the imaginary setting plane B. In this example, the number of rows of the heat exchange panels 322 is equal in the peripheral direction of the imaginary setting plane B in

the heat exchange section 321a. Specifically, in the heat exchange section 321a, the number of rows of the heat exchange panels 322 is equal (two in this example) at any position of the peripheral direction of the imaginary setting plane B. Other configurations are the same as those of the first embodiment.

**[0036]** In the outdoor unit 1 described above, the air flow resistance  $\Delta P$  in the heat exchange section 321a present in the region 41 of the regions 41 and 42 closest to the fan 311 is equalized in the peripheral direction of the imaginary setting plane B. Thus, the reduction of the unevenness in the air flow distribution in the rotation direction of the fan 311 can be further achieved around the fan 311, thereby being capable of further achieving the suppression of noise during the rotation of the fan 311 and the improvement in the energy efficiency.

**[0037]** Further, in the heat exchange section 321a present in the region 41 of the regions 41 and 42 closest to the fan 311, the number of rows of the heat exchange panels 322 is equal in the peripheral direction of the imaginary setting plane B. Thus, the air flow resistance  $\Delta P$  of the air flow  $V_a$  passing through the heat exchange section 321a can be easily equalized in the peripheral direction of the imaginary setting plane B.

#### Fourth Embodiment

**[0038]** FIG. 14 is a perspective view for illustrating relevant parts of the outdoor unit 1 according to a fourth embodiment of the present invention. Further, FIG. 15 is a schematic view for illustrating each of fins 324 in the heat exchange section 321a illustrated in FIG. 14. In the heat exchange section 321a present in the region 41 of the regions 41 and 42 closest to the fan 311, the plurality of fins 324 provided in the heat transfer pipes (refrigerant pipes) allowing passage of the refrigerant are arrayed so as to be spaced away from each other in the peripheral direction of the imaginary setting plane B. Each of the fins 324 is a plate which is arranged to be perpendicular to the peripheral direction of the imaginary setting plane B and along the axis A. A space dimension (fin pitch)  $F_p$  between the fins 324 in the peripheral direction of the imaginary setting plane B is adjusted, to thereby equalize the air flow resistance  $\Delta P$  [Pa] of the air flow  $V_a$  passing through the heat exchange section 321a in the peripheral direction of the imaginary setting plane B. In this example, the fin pitches  $F_p$  are the same at any position in the peripheral direction of the imaginary setting plane B in the heat exchange section 321a. Other configurations are the same as those of the first embodiment.

**[0039]** In the outdoor unit 1 described above, the fin pitches  $F_p$  in the heat exchange section 321a present in the region 41 closest to the fan 311 are the same at any position in the peripheral direction of the imaginary setting plane B. Thus, the air flow resistance  $\Delta P$  of the air flow  $V_a$  passing through the heat exchange section 321a can easily be equalized in the peripheral direction of the imaginary setting plane B.

**[0040]** In the example described above, the air flow resistance  $\Delta P$  is equalized in the peripheral direction of the imaginary setting plane B by equalizing the fin pitches  $F_p$  in the heat exchange section 321a in the peripheral direction of the imaginary setting plane B. However, the air flow resistance  $\Delta P$  in the heat exchange section 321a may also be equalized in the peripheral direction of the imaginary setting plane B by equalizing shapes of the fins 324 in the heat exchange section 321a in the peripheral direction of the imaginary setting plane B. For example, when the heat exchange section 321a is configured so that the plurality of heat transfer pipes are arranged in the peripheral direction of the imaginary setting plane B so as to be spaced away from each other and fins having a wave-like shape are provided between the heat transfer pipes, the shapes of the fins may be equalized in the peripheral direction of the imaginary setting plane B by equalizing pitches between the heat transfer pipes in the peripheral direction of the imaginary setting plane B.

#### Fifth Embodiment

**[0041]** FIG. 16 is a perspective view for illustrating relevant parts of the outdoor unit 1 according to a fifth embodiment of the present invention. Further, FIG. 17 is a sectional view taken along the plane XVII of FIG. 16. The heat exchange section 321a that is present in the region 41 of the regions 41 and 42 closest to the fan 311 includes the heat exchange panels 322. In this example, the number of rows of the heat exchange panel 322 in the heat exchange section 321a is one.

**[0042]** The heat exchange panel 322 includes a plurality of heat transfer pipes (refrigerant pipes) 325, which are arrayed in the direction along the axis A so as to be spaced away from each other and arranged along the peripheral direction of the imaginary setting plane B, and the plurality of fins 324 which are arrayed in the peripheral direction of the imaginary setting plane B so as to be spaced away from each other provided in each of the heat transfer pipes. Each of the fins 324 is arranged so as to be perpendicular to the peripheral direction of the imaginary setting plane B and arranged along the axis A. The heat transfer pipes 325 pass through each of the fins 324.

**[0043]** The air flow resistance  $\Delta P$  [Pa] of the air flow  $V_a$  passing through the heat exchange section 321a is equalized in the peripheral direction of the imaginary setting plane B through adjustment of a sectional shape and a sectional size of each of the heat transfer pipes 325 in the peripheral direction of the imaginary setting plane B. In this example, the sectional shape and the sectional size of each of the heat transfer pipes 325 are the same at any position in the peripheral direction of the imaginary setting plane B. Further, in this example, each of the heat transfer pipes 325 is formed as a circular pipe having an outer diameter  $D$ . Other configurations are the same as those of the first embodiment.

**[0044]** As described above, the equalization of the air flow resistance  $\Delta P$  in the peripheral direction of the imaginary setting plane B can be achieved in the heat exchange section 321a even by equalizing the sectional shapes and the sectional sizes of the heat transfer pipes 325 in the heat exchange section 321a in the peripheral direction of the imaginary setting plane B.

**[0045]** Although the sectional shape of each of the heat transfer pipes 325 is circular in the above-mentioned example, the sectional shape of each of the heat transfer pipes 325 may also be a flattened shape (for example, a rectangular shape or the like). When the sectional shape of each of the heat transfer pipes 325 is rectangular, a dimension of a short side D1 and a dimension of a long side D2 of the cross section having the rectangular shape are set equal for the heat transfer pipes 325, and the heat transfer pipes 325 are arranged so that the long side D2 of the rectangle is perpendicular to the direction along the axis A, as illustrated in FIG. 18. Even in the manner described above, the air flow resistance  $\Delta P$  can be equalized in the peripheral direction of the imaginary setting plane B in the heat exchange section 321a.

**[0046]** Further, the number of rows of the heat exchange panels 322 in the heat exchange section 321a may also be plural. In this case, the sectional shape and the sectional size of each of the heat transfer pipes 325 may be set different for each of the heat exchange panels 322. For example, as illustrated in FIG. 19, the number of rows of the heat exchange panels 322 in the heat exchange section 321a may be set to two, and the sectional shape of each of the heat transfer pipes 325 in one heat exchange panel 322 may be circular, whereas the sectional shape of each of the heat transfer pipes 325 in another heat exchange panel 322 may be rectangular.

**[0047]** Further, the plurality of heat transfer pipes 325 having sectional shapes different from each other may be incorporated into the common heat exchange panel 322 in the heat exchange section 321a. For example, as illustrated in FIG. 20, the heat transfer pipes 325 each having the rectangular sectional shape and the heat transfer pipes 325 each having the circular sectional shape may be arranged in an array in the common heat exchange panel 322.

#### Sixth Embodiment

**[0048]** FIG. 21 is a perspective view for illustrating relevant parts of the outdoor unit 1 according to a sixth embodiment of the present invention. Further, FIG. 22 is a sectional view taken along the plane XXII of FIG. 21. The heat exchange section 321a that is present in the region 41 of the regions 41 and 42 closest to the fan 311 includes the heat exchange panels 322. In this example, the number of rows of the heat exchange panel 322 in the heat exchange section 321a is one. In the heat exchange panel 322 included in the heat exchange section 321a, the heat transfer pipes 325 are arrayed in the direction

along the axis A so as to be spaced away from each other. The air flow resistance  $\Delta P$  [Pa] of the air flow Va passing through the heat exchange section 321a is equalized in the peripheral direction of the imaginary setting plane B through adjustment of a center distance (heat transfer pipe pitch)  $D_p$  between the heat transfer pipes 325. In this example, the center distance (heat transfer pipe pitch)  $D_p$  between the heat transfer pipes 325 is equal in the peripheral direction of the imaginary setting plane B in the heat exchange section 321a. Further, in this example, the sectional shape of each of the heat transfer pipes 325 is circular. Other configurations are the same as those of the fifth embodiment.

**[0049]** As described above, the equalization of the air flow resistance  $\Delta P$  in the peripheral direction of the imaginary setting plane B in the heat exchange section 321a can be achieved even by equalizing the heat transfer pipe pitches  $D_p$  in the heat transfer section 321a that is present in the region 41 closest to the fan 311 in the peripheral direction of the imaginary setting plane B.

**[0050]** Although the sectional shape of each of the heat transfer pipes 325 is circular in the above-mentioned example, the sectional shape of each of the heat transfer pipes 325 may also be a flattened shape (for example, a rectangular shape or the like).

#### Seventh Embodiment

**[0051]** FIG. 24 is a perspective view for illustrating relevant parts of the outdoor unit 1 according to a seventh embodiment of the present invention. FIG. 25 is a perspective view for illustrating relevant parts of the outdoor unit 1 for illustrating peripheral lengths of the heat exchange sections 321a, 321b, and 321c illustrated in FIG. 24. In this embodiment, the number of regions set for the heat exchanger 321 is three. Specifically, in the heat exchanger 321, three regions 41 to 43 arrayed in the direction along the axis A are set. Of the regions 41 to 43, the region 41 is a region closest to the fan 311. The region 42 is a region second closest to the fan 311. The region 43 is a region most away from the fan 311. The heat exchanger 321 is segmented into the three heat exchange sections 321a, 321b, and 321c that are respectively present in the regions 41 to 43.

**[0052]** In the regions 41 to 43, lengths La, Lb, and Lc of the heat exchange sections 321a, 321b, and 321c along the peripheral direction of the imaginary setting plane B are longer in the order of the heat exchange section 321c that is present in the region 43 most away from the fan 311, the heat exchange section 321b that is present in the region 42 second closest to the fan 311, and the heat exchange section 321a that is present in the region 41 closest to the fan 311 ( $L_a > L_b > L_c$ ). Specifically, the lengths La, Lb, and Lc of the heat exchange sections 321a, 321b, and 321c in the peripheral direction of the imaginary setting plane B are longer in the heat exchange section that is present in the region closer to the fan 311.

**[0053]** In this example, the heat exchange section 321a that is present in the region 41 closest to the fan 311 and the heat exchange section 321b that is present in the region second closest to the fan 311 are arranged along all the four plane sections B1 to B4 of the imaginary setting plane B, whereas the heat exchange section 321c that is present in the region 43 most away from the fan 311 is arranged along the remaining three plane sections B1 to B3 excluding any one of the four plane sections B1 to B4 of the imaginary setting plane B. The compressor, the electromagnetic valve, and the heat transfer pipes included in the refrigeration cycle device 32 are arranged in the regions 42 and 43 that are farther away from the fan 311 than the region 41.

**[0054]** In the regions 41 to 43, there are generated an area in which the heat exchange sections 321a, 321b, and 321c are present and an area in which the heat exchange sections 321a, 321b, and 321c are absent in the rotation direction of the fan 311. A section of each of the side panels 24 of the casing 2, which covers an area in which the heat exchange sections 321a, 321b, and 321c are present, is formed as a panel air passage section (not shown) configured to allow passage of air (air flow), whereas a section that covers the area in which the heat exchange sections 321a, 321b, and 321c are absent is formed as the panel shielding section 242 configured to block the passage of the air (air flow). Other configurations are the same as those of the first embodiment.

**[0055]** As described above, even when the number of regions arrayed in the direction along the axis A is three, and the heat exchanger 321 is segmented into the three heat exchange sections 321a, 321b, and 321c that are respectively present in the regions 41 to 43, the unevenness in the air velocity distribution in the rotation direction of the fan 311 can be reduced around the fan 311 by setting the lengths La, Lb, and Lc of the heat exchange sections 321a, 321b, and 321c in the peripheral direction of the imaginary setting plan B to be longer in the heat exchange section that is present closer to the fan 311. As a result, the reduction of noise during the rotation of the fan 311 and the improvement in the energy efficiency can be achieved.

#### Eighth Embodiment

**[0056]** FIG. 26 is a perspective view for illustrating relevant parts of the outdoor unit 1 according to an eighth embodiment of the present invention. Further, FIG. 27 is a schematic sectional view taken along the plane XXVII of FIG. 26. In the casing 2, a drive control device 33 is accommodated. The drive control device 33 is configured to control drive of the devices (such as, for example, the fan motor 312, the motor for the compressor, and the electromagnetic valve) in the casing 2. The drive control device 33 includes electric components including a circuit board, and a box configured to accommodate the electric components therein.

**[0057]** The drive control device 33 is arranged in the

region 42 farther away from the fan 311 than the region 41. Further, the drive control device 33 is arranged in an area in which the heat exchanger 321 (specifically, the heat exchange section 321b) is absent in the rotation direction of the fan 311. Further, the drive control device 33 is mounted to the panel shielding section 242 of the side panels 24 in the casing 2. As a result, the drive control device 33 is under a state of being covered with the panel shielding section 242. A heat sink 34 configured to cool the circuit board included in the drive control device 33 is provided on a surface of the drive control device 33 on a side closer to the axis A. Other configurations are the same as those of the second embodiment.

**[0058]** In the outdoor unit 1 described above, the drive control device 33 accommodated within the casing 2 is arranged in the region 42 farther away from the fan 311 than the region 41 and is provided on the panel shielding section 242 of the side panels 24. Thus, the drive control device 33 can be protected from an environment (for example, wind, rain, and the like) outside the casing 2 by the panel shielding section 242. Further, a position of the drive control device 33 is away from the fan 31. Therefore, influence of the drive control device 33 on the air velocity distribution around the fan 311 can be reduced, thereby being capable of suppressing an increase in the unevenness in the air velocity distribution caused by the arrangement of the drive control device 33 in the casing 2. Further, the drive control device 33 is arranged in the region 42 in which an area occupied by the heat exchanger 321 is small. Thus, a space for arrangement of the drive control device 33 and the heat sink 34 can be easily secured, and maintenance work for the drive control device 33 can be facilitated.

#### Ninth Embodiment

**[0059]** FIG. 28 is a perspective view for illustrating relevant parts of the outdoor unit 1 according to a ninth embodiment of the present invention. FIG. 29 is a schematic sectional view taken along the plane XXIX of FIG. 28. An access port 25 for allowing access from the outside of the casing 2 to the inside of the casing 2 is formed in the panel shielding section 242 of the side panels 24. The access port 25 is positioned in the region 42 farther away from the fan 311 than the region 41. Further, a lid 26 configured to open and close the access port 25 is provided on the panel shielding section 242. The lid 26 is formed of a plate for blocking the passage of the air (air flow). Other configurations are the same as those of the second embodiment.

**[0060]** In the outdoor unit 1 described above, the access port 25 is formed in the panel shielding section 242 of the side panel 24, and the access port 25 is positioned in the region 42 farther away from the fan 311 than the region 41. Therefore, influence of the access port 25 on the air velocity distribution around the fan 311 can be reduced, thereby being capable of suppressing an increase in the unevenness in the air velocity distribution

caused by the formation of the access port 25 in the panel shielding section 242 of the side panel 24. Further, the access port 25 is formed in the panel shielding section 242 that is positioned in the region 42 in which the area occupied by the heat exchanger 23 is small. Thus, a size of the access port 25 can be easily secured while avoiding the heat exchanger 321. As a result, for example, maintenance work for a heavy component such as the compressor can be further facilitated.

**[0061]** In each of the embodiments described above, when the imaginary setting plane B is viewed in the direction along the axis A, the four plane sections B1 to B4 respectively overlapping with the sides of the quadrangle that surrounds the entire periphery of the axis A are included in the imaginary setting plane B. However, the polygon that surrounds the entire periphery of the axis A is not limited to the quadrangle, and may also be a triangle, a hexagon, or the like. In such a case, the number of plane sections respectively overlapping with sides of the polygon is the same as the number of sides of the polygon.

**[0062]** Further, although the number of regions 41 and 42 arrayed in the direction along the axis A is two in the first to sixth, eighth, and ninth embodiments, the number of regions arrayed in the direction along the axis A is, according to claim 1, three or more.

**[0063]** Further, in the third to sixth embodiments, the configuration of the heat exchange section 321a that is present in the region 41 closest to the fan 311 may be applied to the configuration of the heat exchange section 321b that is present in the region 42 farther away from the fan 311 than the region 41. In this manner, the equalization of the air flow resistance in the peripheral direction of the imaginary setting plane B can be achieved not only in the heat exchange section 321a but also in the heat exchange section 321b. As a result, the unevenness in the air velocity distribution around the fan 311 can be further reduced.

**[0064]** The present invention is not limited to the embodiments described above, and can be carried out with various changes within the scope of the claims 1-6. The present invention can also be carried out with combinations of the embodiments described above as long as the combinations stay within the scope of claims 1-6.

## Claims

### 1. An air conditioning unit, comprising:

a fan (311), which is rotatable about an axis (A) thereof; and  
a heat exchanger (321), which is arranged at a position shifted relative to the fan (311) in an axial direction of the fan (311),

the heat exchanger (321) being arranged in an imaginary setting plane (B) surrounding

the axis (A),

the heat exchanger (321) being segmented into three or more heat exchange sections (321a,321b,321c) which are provided respectively in three or more regions (41,42,43) arrayed in the axial direction of the fan (311),

wherein, assuming that a direction along the imaginary setting plane (B) on a plane perpendicular to the axis (A) is a peripheral direction of the imaginary setting plane (B), among lengths of the plurality of heat exchange sections (321a,321b,321c) along the peripheral direction of the imaginary setting plane (B), a length of the heat exchange section which is present in a region closer to the fan (311) is longer, the air-conditioning unit further comprising a casing (2) configured to accommodate the fan (311) and the heat exchanger (321), the casing (2) comprising a plurality of side panels (24) surrounding the axis (A) of the fan (311), at least any one of the plurality of side panels (24) comprising a panel shielding section (242) configured to block passage of an air flow, the panel shielding section (242) being configured to cover an area in which the heat exchanger (321) is absent in a rotation direction of the fan (311),

wherein the panel shielding section (242) has an access port (25) for allowing access from an outside of the casing (2) to an inside of the casing (2), and

wherein the access port (25) is positioned in the region (42) farther away from the fan (311) than the region (41) closest to the fan (311).

2. An air-conditioning unit according to claim 1, wherein, when the imaginary setting plane (B) is viewed along the axial direction of the fan (311), the imaginary setting plane (B) comprises a plurality of plane sections (B1-B4) overlapping respectively with sides of a polygon surrounding the axis (A), and wherein, when the heat exchanger (321) is viewed along the axial direction of the fan (311), one of the plurality of heat exchange sections (321a) provided in one of the plurality of regions (41) closest to the fan (311) is arranged along all of the plurality of plane sections (B1-B4).
3. An air-conditioning unit according to any one of claims 1 to 2, wherein air flow resistance of the one of the plurality of heat exchange sections (321a) provided in the one of the plurality of regions (41) closest to the fan (311) is equalized in the peripheral direction of the imaginary setting plane (B).
4. An air-conditioning unit according to claim 3,

wherein the one of the plurality of heat exchange sections (321a) provided in the one of the plurality of regions (41) closest to the fan (311) comprises a plurality of heat exchange panels (322) arrayed in an overlapping manner with the axis (A) of the fan (311) being set on an inner side, and wherein a number of rows of the plurality of heat exchange panels (322) in the one of the plurality of heat exchange sections (321a) provided in the one of the plurality of regions (41) closest to the fan (311) is equalized in the peripheral direction of the imaginary setting plane (B).

5. An air-conditioning unit according to claim 3, wherein the one of the plurality of heat exchange sections (321a) provided in the one of the plurality of regions (41) closest to the fan (311) comprises:

a plurality of heat transfer pipes (325); and a plurality of fins (324) provided in the plurality of heat transfer pipes (325), and wherein, in the one of the plurality of heat exchange sections (321a) provided in the one of the plurality of regions (41) closest to the fan (311), at least one of a shape of each of the plurality of fins (324), a pitch between the plurality of fins (324), an outer shape of each of the plurality of heat transfer pipes (325), or a pitch between the plurality of heat transfer pipes (325) is equalized in the peripheral direction of the imaginary setting plane (B).

6. An air conditioning unit according to any one of claims 1 to 5, further comprising:

a casing (2) configured to accommodate the fan (311) and the heat exchanger (321) therein,

the casing (2) comprising a plurality of side panels (24) surrounding the axis (A) of the fan (311), at least any one of the plurality of side panels (24) comprising a panel shielding section (242) configured to block passage of an air flow, the panel shielding section (242) being configured to cover an area in which the heat exchanger (321) is absent in a rotation direction of the fan (311); and

a drive control device (33) configured to control drive of a device in the casing (2), the drive control device (33) being mounted to the panel shielding section (242) in the casing (2) and arranged in the region (42) farther away from the fan (311) than the region (42) closest to the fan (311).

## Patentansprüche

1. Klimatisierungseinheit, die Folgendes umfasst:

einen Lüfter (311), der um eine Achse (A) desselben rotierbar ist; und einen Wärmetauscher (321), der an einer Position angeordnet ist, die in Bezug auf den Lüfter (311) in einer axialen Richtung des Lüfters (311) versetzt ist,

wobei der Wärmetauscher (321) in einer imaginären Einstellebene (B) angeordnet ist, die die Achse (A) umgibt, wobei der Wärmetauscher (321) in drei oder mehr Wärmetauscherabschnitte (321a, 321b, 321c) segmentiert ist, die entsprechend in drei oder mehr Regionen (41, 42, 43) bereitgestellt sind, die in der axialen Richtung des Lüfters (311) angeordnet sind,

wobei unter der Annahme, dass eine Richtung entlang der imaginären Einstellebene (B) auf einer Ebene normal auf die Achse (A) eine Umfangsrichtung der imaginären Einstellebene (B) ist, unter den Längen der Vielzahl von Wärmetauscherabschnitten (321a, 321b, 321c) entlang der Umfangsrichtung der imaginären Einstellebene (B) eine Länge des Wärmeaustauschabschnitts, der in einer Region näher an dem Lüfter (311) vorliegt, länger ist, die Klimatisierungseinheit ferner ein Gehäuse (2) umfasst, das ausgelegt ist, um den Lüfter (311) und den Wärmetauscher (321) aufzunehmen, das Gehäuse (2) eine Vielzahl von Seitenplatten (24) umfasst, die die Achse (A) des Lüfters (311) umgeben, zumindest eine beliebige aus der Vielzahl von Seitenplatten (24) einen Plattenabdeckabschnitt (242) umfasst, der ausgelegt ist, um das Hindurchtreten eines Luftstroms zu blockieren, der Plattenabdeckabschnitt (242) ausgelegt ist, um einen Bereich in einer Rotationsrichtung des Lüfters (311) abzudecken, in dem der Wärmetauscher (321) nicht vorhanden ist; der Plattenabdeckabschnitt (242) eine Zugriffsöffnung (25) aufweist, um Zugriff von einer Außenseite des Gehäuses (2) auf eine Innenseite des Gehäuses (2) zu ermöglichen, und wobei die Zugriffsöffnung (25) in der Region (42) angeordnet ist, die weiter von dem Lüfter (311) entfernt ist als die Region (41), die dem Lüfter (311) am nächsten ist.

2. Klimatisierungseinheit nach Anspruch 1, wobei die imaginäre Einstellebene (B), wenn die

- imaginäre Einstellebene (B) entlang einer axialen Richtung des Lüfters (311) betrachtet wird, eine Vielzahl von Ebenenabschnitten (B1-B4) umfasst, die jeweils mit Seiten eines Polygons überlappen, das die Achse (A) umgibt, und
- wobei, wenn der Wärmetauscher (321) entlang der axialen Richtung des Lüfters (311) betrachtet wird, einer aus der Vielzahl von Wärmetauscherabschnitten (321a), die in einer aus der Vielzahl von Regionen (41) bereitgestellt ist, die dem Lüfter (311) am nächsten ist, entlang aller aus der Vielzahl von Ebenenabschnitten (B1-B4) angeordnet ist.
3. Klimatisierungseinheit nach einem der Ansprüche 1 bis 2, wobei der Luftstromwiderstand des einen aus der Vielzahl von Wärmetauscherabschnitten (321a), der in der einen aus der Vielzahl von Regionen (41) bereitgestellt ist, die dem Lüfter (311) am nächsten ist, in der Umfangsrichtung der imaginären Einstellebene (B) ausgeglichen wird.
4. Klimatisierungseinheit nach Anspruch 3, wobei der eine aus der Vielzahl von Wärmetauscherabschnitten (321a), der in der einen aus der Vielzahl von Regionen (41) bereitgestellt ist, die dem Lüfter (311) am nächsten ist, eine Vielzahl von Wärmetauscherplatten (322) umfasst, die auf überlappende Weise angeordnet sind, wobei die Achse (A) des Lüfters (311) auf einer Innenseite festgelegt ist, und wobei eine Anzahl von Reihen aus der Vielzahl von Wärmetauscherplatten (322) in dem einen aus der Vielzahl von Wärmetauscherabschnitten (321a), der in der einen aus der Vielzahl von Regionen (41) bereitgestellt ist, die dem Lüfter (311) am nächsten ist, in der Umfangsrichtung der imaginären Einstellebene (B) ausgeglichen wird.
5. Klimatisierungseinheit nach Anspruch 3, wobei der eine aus der Vielzahl von Wärmetauscherabschnitten (321a), der in der einen aus der Vielzahl von Regionen (41) bereitgestellt ist, die dem Lüfter (311) am nächsten ist, Folgendes umfasst:
- eine Vielzahl von Wärmeübertragungsrohren (325); und
- eine Vielzahl von Rippen (324), die in der Vielzahl von Wärmeübertragungsrohren (325) bereitgestellt sind,
- wobei in dem einen aus der Vielzahl von Wärmetauscherabschnitten (321a), der in der einen aus der Vielzahl von Regionen (41) bereitgestellt ist, die dem Lüfter (311) am nächsten ist, zumindest eines aus einer Form jeder der Vielzahl von Rippen (324), einem Teilungsabstand zwischen der Vielzahl von Rippen (324), einer Außenform jedes der Vielzahl von Wärmeübertragungsrohren (325) und einem Teilungsabstand zwischen der Vielzahl von Wärmeübertra-

gungsrohren (325) in der Umfangsrichtung der imaginären Einstellebene (B) ausgeglichen wird.

- 5 6. Klimatisierungseinheit nach einem der Ansprüche 1 bis 5, ferner umfassend:

- ein Gehäuse (2), das ausgelegt ist, um den Lüfter (311) und den Wärmetauscher (321) darin aufzunehmen,
- wobei das Gehäuse (2) eine Vielzahl von Seitenplatten (24) umfasst, die die Achse (A) des Lüfters (31) umgeben,
- zumindest eine beliebige aus der Vielzahl von Seitenplatten (24) einen Plattenabdeckabschnitt (242) umfasst, der ausgelegt ist, um das Hindurchtreten eines Luftstroms zu blockieren, der Plattenabdeckabschnitt (242) ausgelegt ist, um einen Bereich in einer Rotationsrichtung des Lüfters (311) abzudecken, in dem der Wärmetauscher (321) nicht vorhanden ist; und
- eine Antriebssteuervorrichtung (33) ausgelegt ist, um den Antrieb einer Vorrichtung in dem Gehäuse (2) zu steuern,
- die Antriebssteuervorrichtung (33) an dem Plattenabdeckabschnitt (242) in dem Gehäuse (2) angebracht und in der Region (42) angeordnet ist, die weiter von dem Lüfter (311) entfernt ist als die Region (42), die dem Lüfter (311) am nächsten ist.

## Revendications

- 35 1. Unité de climatisation comprenant :
- un ventilateur (311) qui peut tourner autour de son axe (A) ; et
- un échangeur de chaleur (321) qui est agencé dans une position décalée par rapport au ventilateur (311) dans une direction axiale du ventilateur (311),
- l'échangeur de chaleur (321) étant agencé dans un plan de pose imaginaire (B) entourant l'axe (A),
- l'échangeur de chaleur (321) étant segmenté en trois sections d'échange de chaleur (321a, 321b, 321c) ou plus qui sont prévues respectivement dans trois régions (41, 42, 43) ou plus disposées dans la direction axiale du ventilateur (311),
- dans laquelle, en supposant qu'une direction le long du plan de pose imaginaire (B) sur un plan perpendiculaire à l'axe (A) est une direction périphérique du plan de pose imaginaire (B), parmi les longueurs de la pluralité de sections d'échange de chaleur (321a, 321b, 321c) le long de la direction périphérique du plan de pose imagi-

- naire (B), une longueur de la section d'échange de chaleur qui est présente dans une région plus à proximité du ventilateur (311) est plus longue, l'unité de climatisation comprenant en outre un carter (2) configuré pour loger le ventilateur (311) et l'échangeur de chaleur (321), le carter (2) comprenant une pluralité de panneaux latéraux (24) entourant l'axe (A) du ventilateur (311), au moins l'un quelconque de la pluralité de panneaux latéraux (24) comprenant une section de protection de panneau (242) configurée pour empêcher le passage d'un flux d'air, la section de protection de panneau (242) étant configurée pour couvrir une zone dans laquelle l'échangeur de chaleur (321) est absent dans une direction de rotation du ventilateur (311), dans laquelle la section de protection de panneau (242) a un orifice d'accès (25) pour permettre l'accès depuis l'extérieur du carter (2) dans un intérieur du carter (2), et dans lequel l'orifice d'accès (25) est positionné dans la région (42) plus à distance du ventilateur (311) que la région (41) la plus proche du ventilateur (311).
2. Unité de climatisation selon la revendication 1, dans laquelle, lorsque le plan de pose imaginaire (B) est observé le long de la direction axiale du ventilateur (311), le plan de pose imaginaire (B) comprend une pluralité de sections de plan (B1-B4) recouvrant respectivement les côtés d'un polygone entourant l'axe (A), et dans laquelle, lorsque l'échangeur de chaleur (321) est observé le long de la direction axiale du ventilateur (311), l'une de la pluralité de sections d'échange de chaleur (321a) prévue dans l'une de la pluralité de régions (41) la plus proche du ventilateur (311) est agencée le long de toute la pluralité de sections de plan (B1-B4).
3. Unité de climatisation selon l'une quelconque des revendications 1 à 2, dans laquelle la résistance d'écoulement d'air de l'une de la pluralité de sections d'échange de chaleur (321a) prévue dans l'une de la pluralité de régions (41) la plus proche du ventilateur (311) est égalisée dans la direction périphérique du plan de pose imaginaire (B).
4. Unité de climatisation selon la revendication 3, dans laquelle l'une de la pluralité de sections d'échange de chaleur (321a) prévue dans l'une de la pluralité de régions (41) la plus proche du ventilateur (311) comprend une pluralité de panneaux d'échange de chaleur (322) disposés en chevauchement avec l'axe (A) du ventilateur (311) placé sur un côté interne, et dans laquelle un certain nombre de rangées de la pluralité de panneaux d'échange de chaleur (322) dans l'une de la pluralité de sections d'échange de chaleur (321a) prévue dans l'une de la pluralité de régions (41) la plus proche du ventilateur (311) est égalisé dans la direction périphérique du plan de pose imaginaire (B).
5. Unité de climatisation selon la revendication 3, dans laquelle l'une de la pluralité de sections d'échange de chaleur (321a) prévue dans l'une de la pluralité de régions (41) la plus proche du ventilateur (311) comprend :
- une pluralité de tuyaux de transfert de chaleur (325) ; et une pluralité d'ailettes (324) prévues dans la pluralité de tuyaux de transfert de chaleur (325), et dans laquelle, dans l'une de la pluralité de sections d'échange de chaleur (321a) prévue dans l'une de la pluralité de régions (41) la plus proche du ventilateur (311), au moins l'un parmi une forme de chacune de la pluralité d'ailettes (324), un pas entre la pluralité d'ailettes (324), une forme externe de chacun de la pluralité de tuyaux de transfert de chaleur (325) ou un pas entre la pluralité de tuyaux de transfert de chaleur (325) est égalisé dans la direction périphérique du plan de pose imaginaire (B).
6. Unité de climatisation selon l'une quelconque des revendications 1 à 5, comprenant en outre :
- un carter (2) configuré pour loger le ventilateur (311) et l'échangeur de chaleur (321) à l'intérieur de ce dernier, le carter (2) comprenant une pluralité de panneaux latéraux (24) entourant l'axe (A) du ventilateur (311), au moins l'un quelconque de la pluralité de panneaux latéraux (24) comprenant une section de protection de panneau (242) configurée pour empêcher le passage d'un flux d'air, la section de protection de panneau (242) étant configurée pour recouvrir une zone dans laquelle l'échangeur de chaleur (321) est absent dans une direction de rotation du ventilateur (311) ; et un dispositif de commande d'entraînement (33) configuré pour commander l'entraînement d'un dispositif dans le carter (2), le dispositif de commande d'entraînement (33) étant monté sur la section de protection de panneau (242) dans le carter (2) et agencé dans la région (42) plus à distance du ventilateur (311) que la région (42) la plus proche du ventilateur (311).

FIG. 1

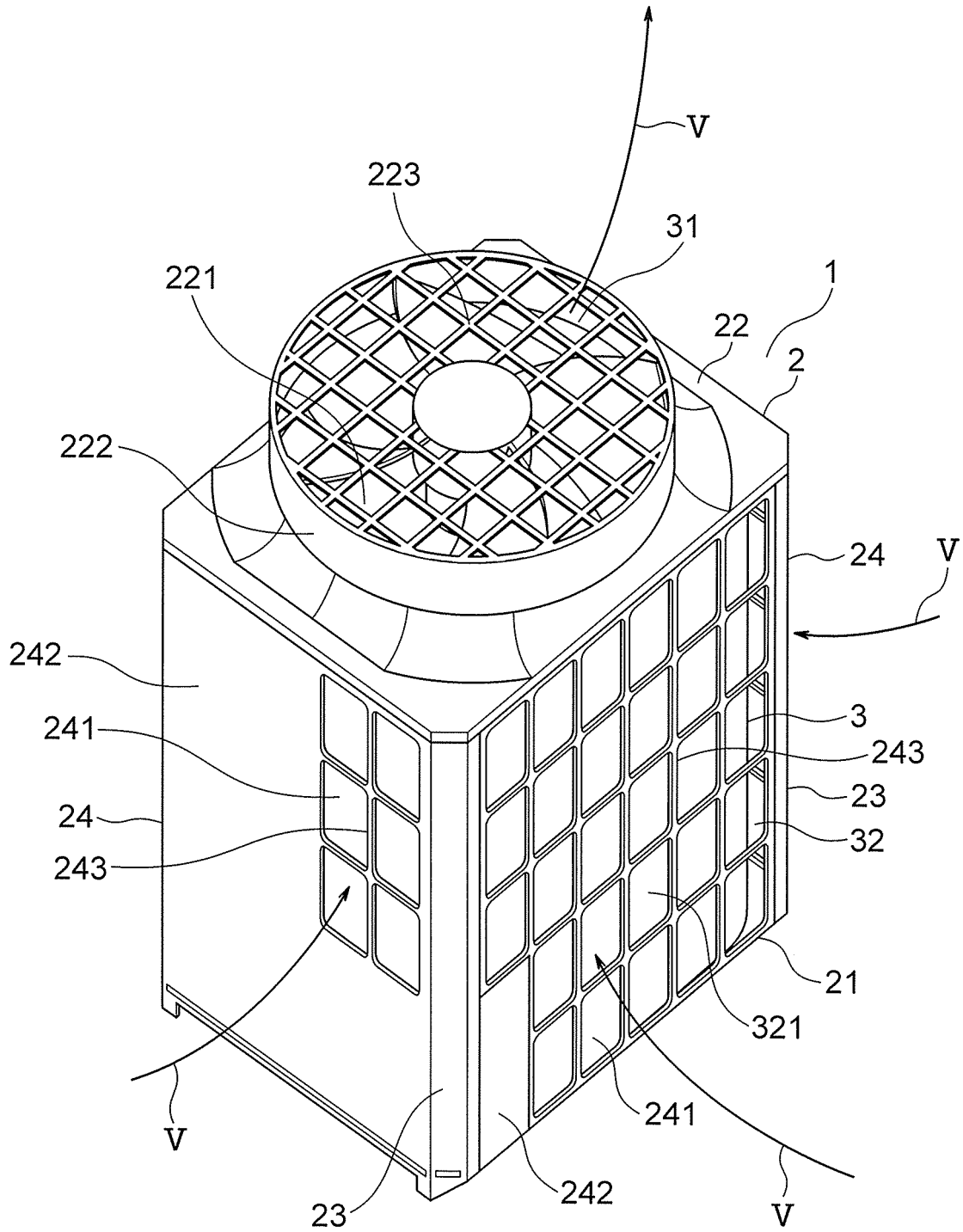



FIG. 3

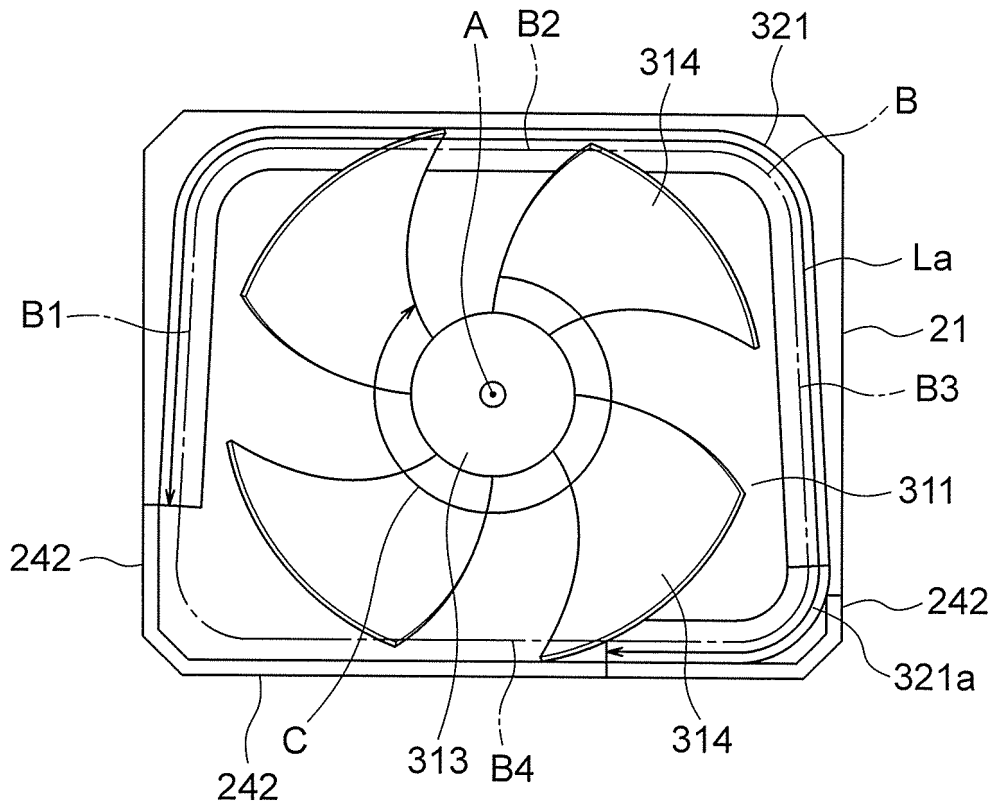





FIG. 6

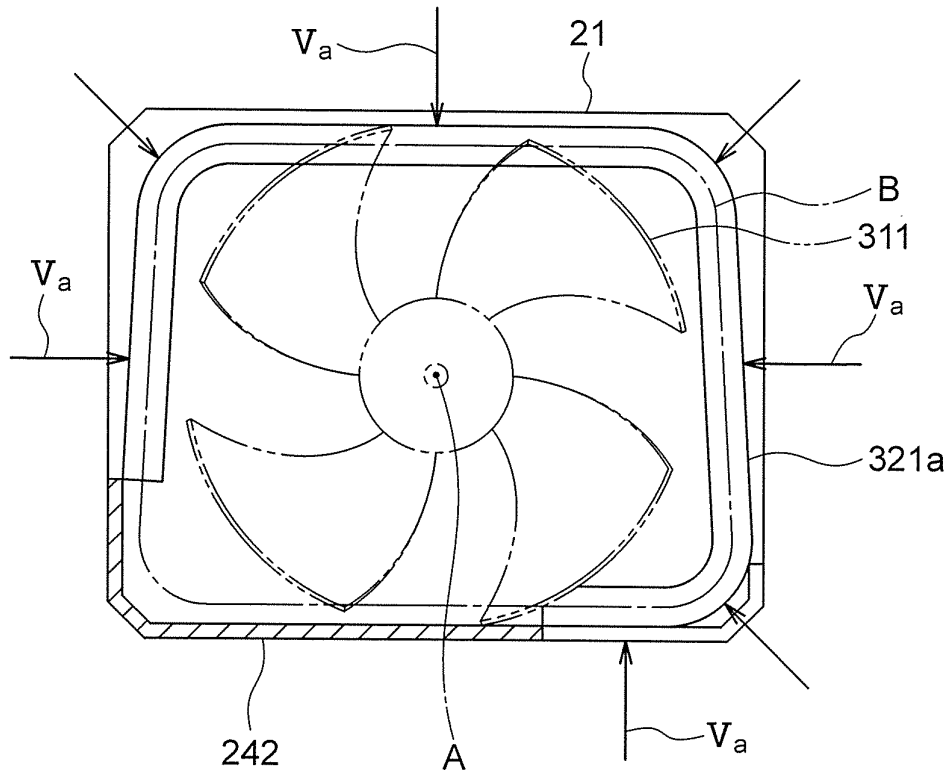

FIG. 7

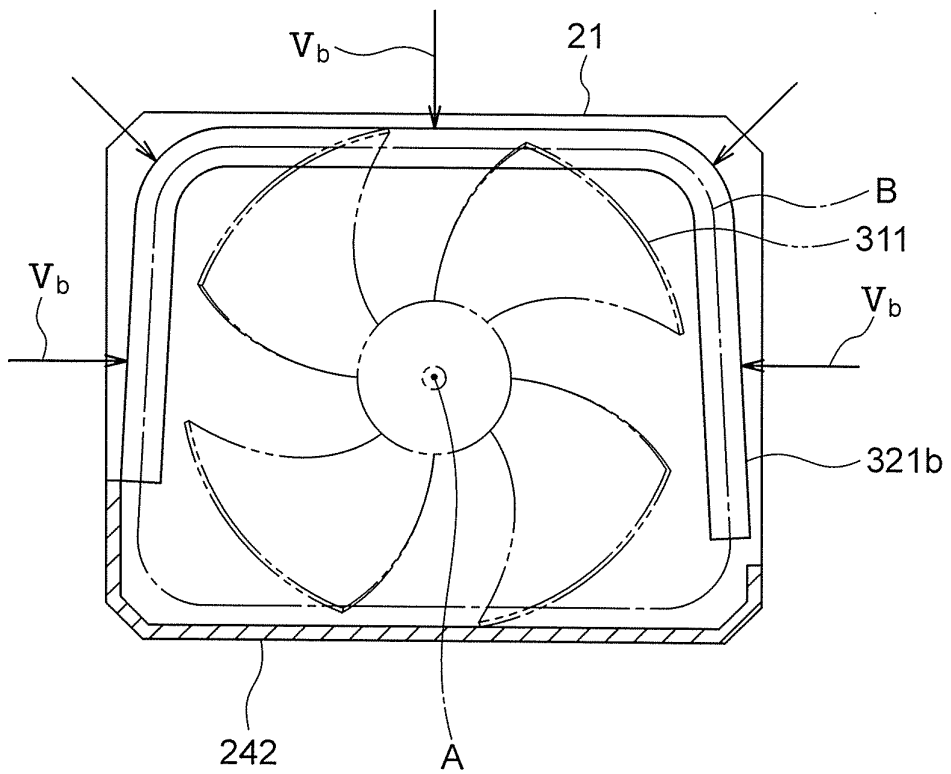

FIG. 8

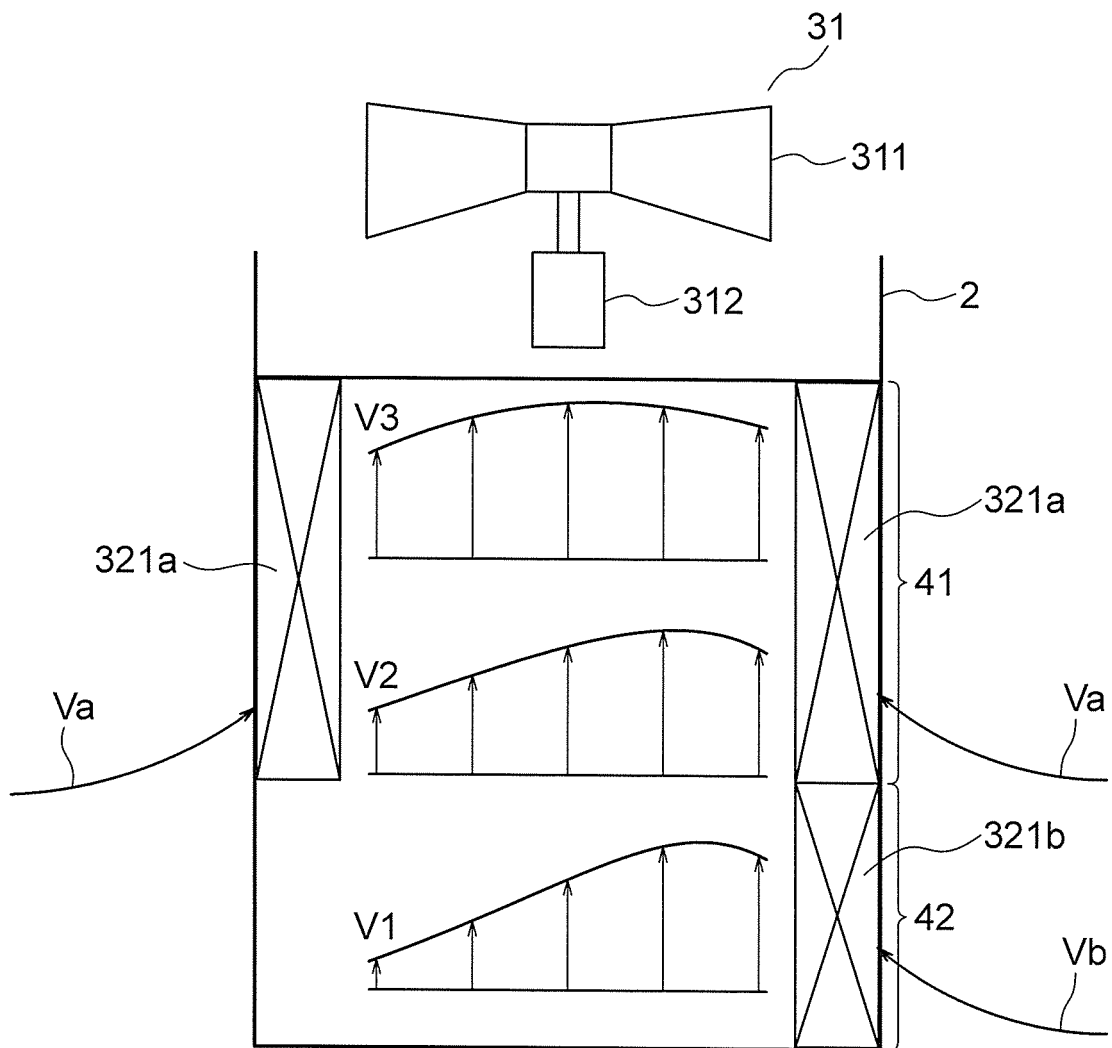

FIG. 9

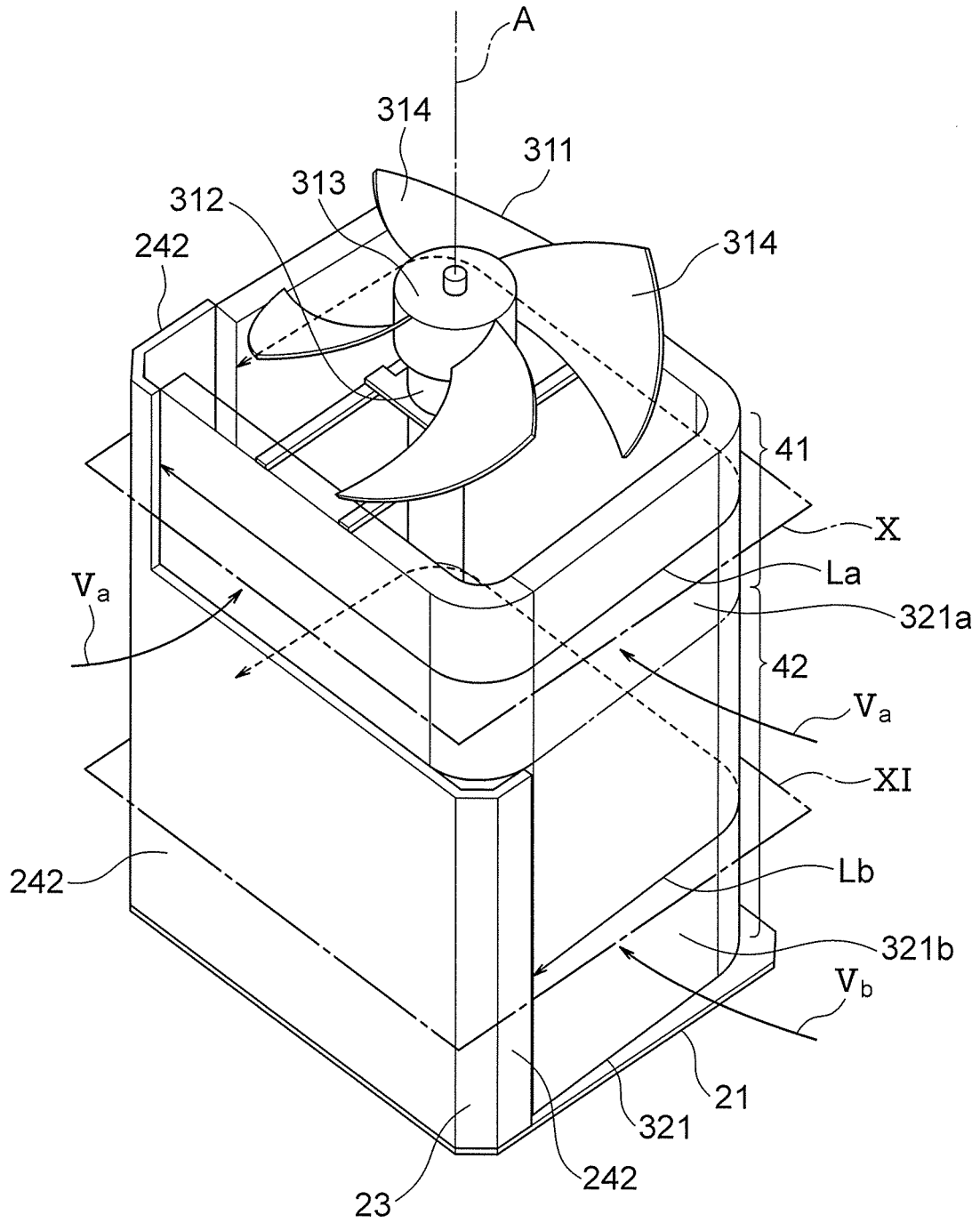

FIG. 10

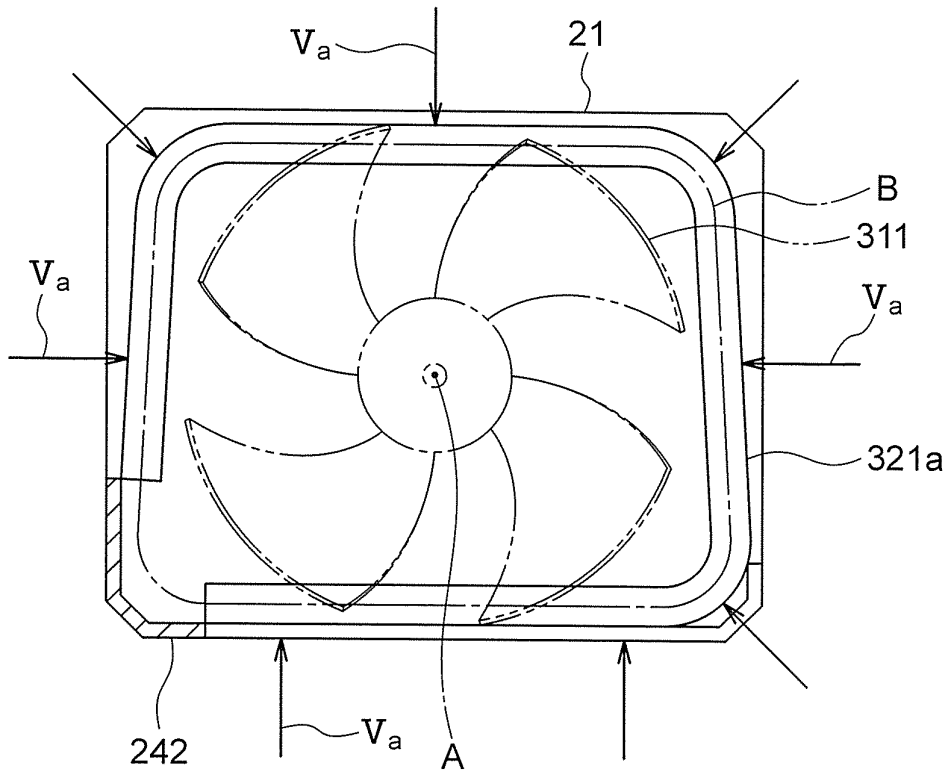

FIG. 11

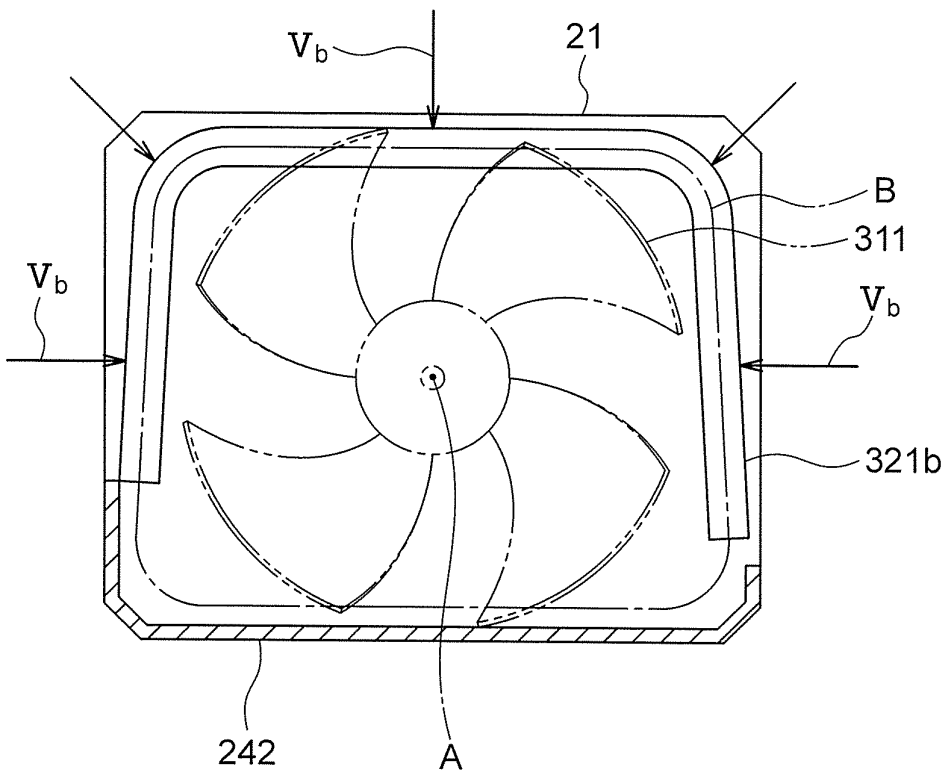

FIG. 12

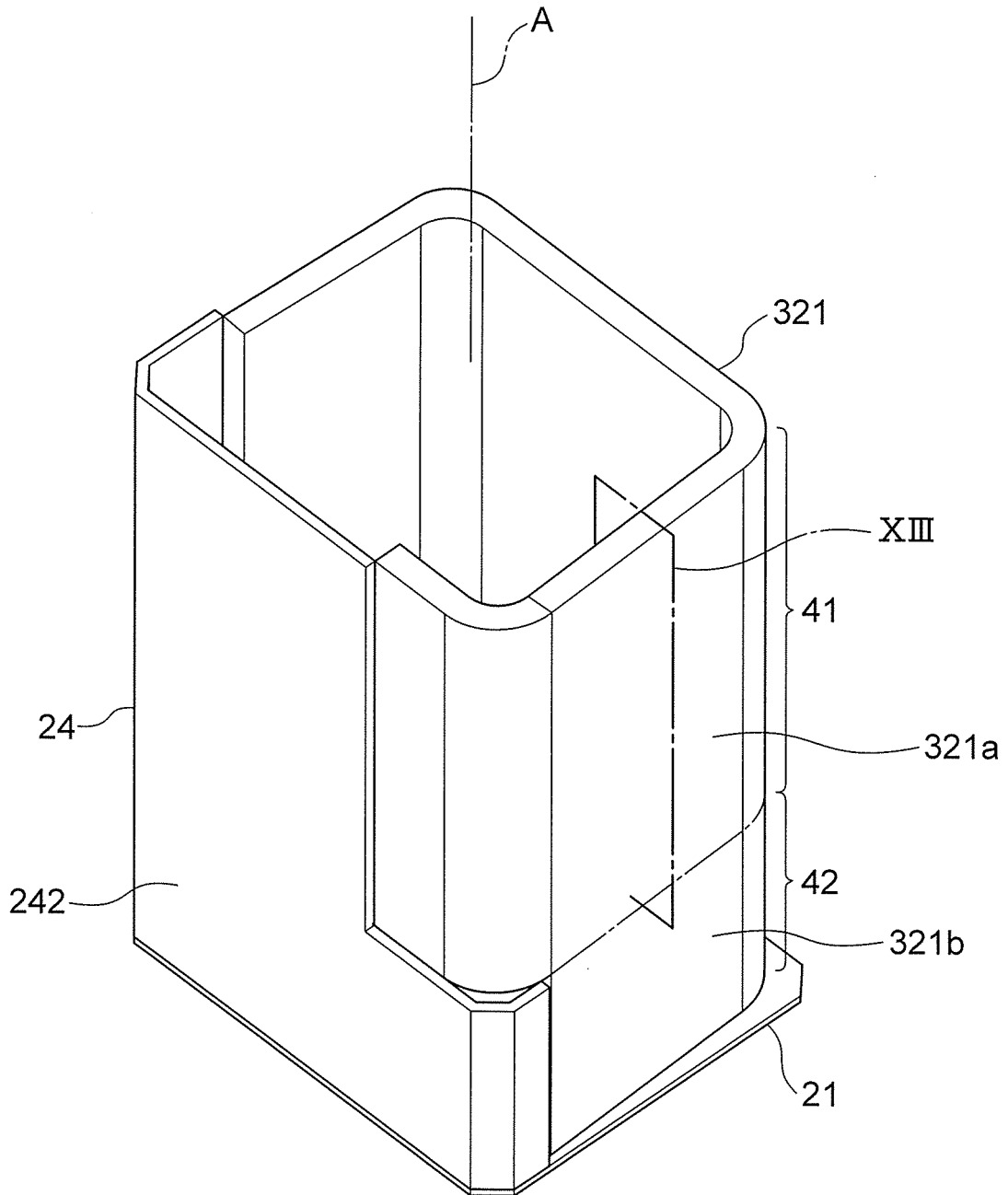

FIG. 13

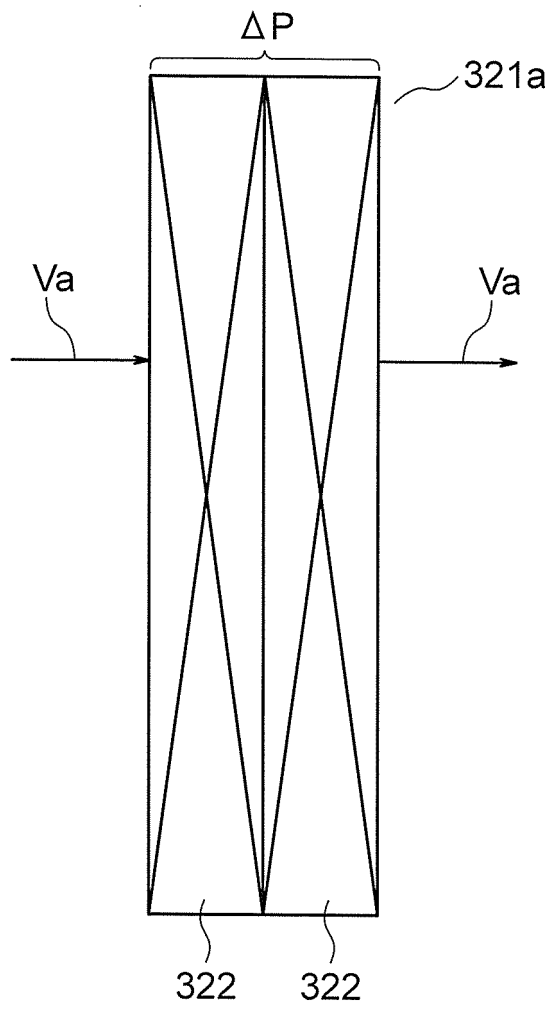

FIG. 14

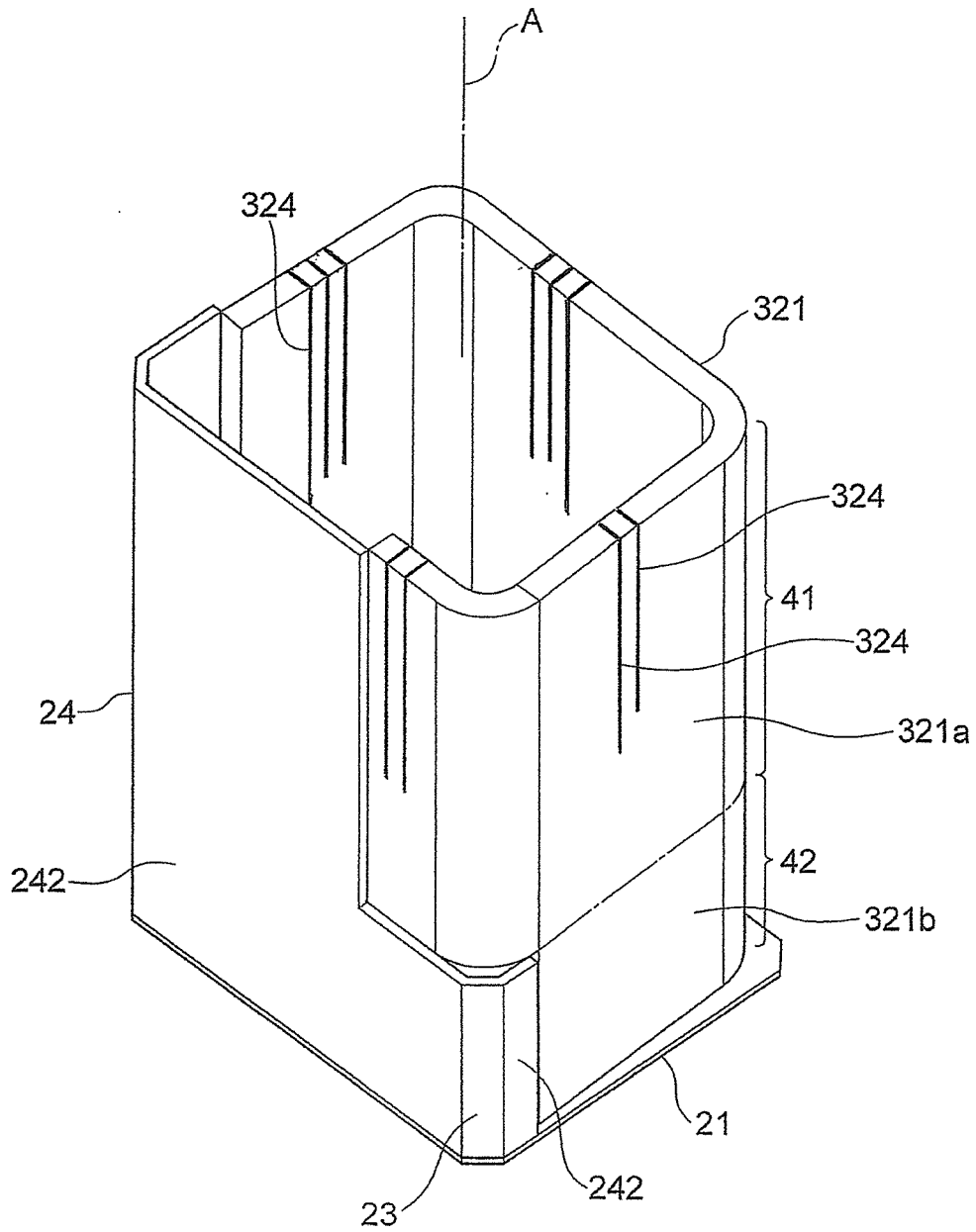

FIG. 15

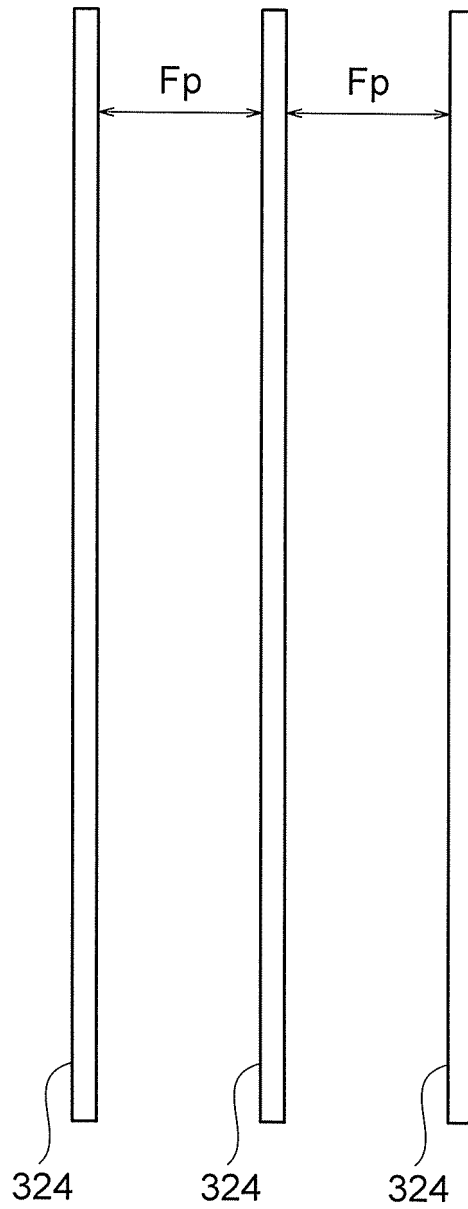

FIG. 16

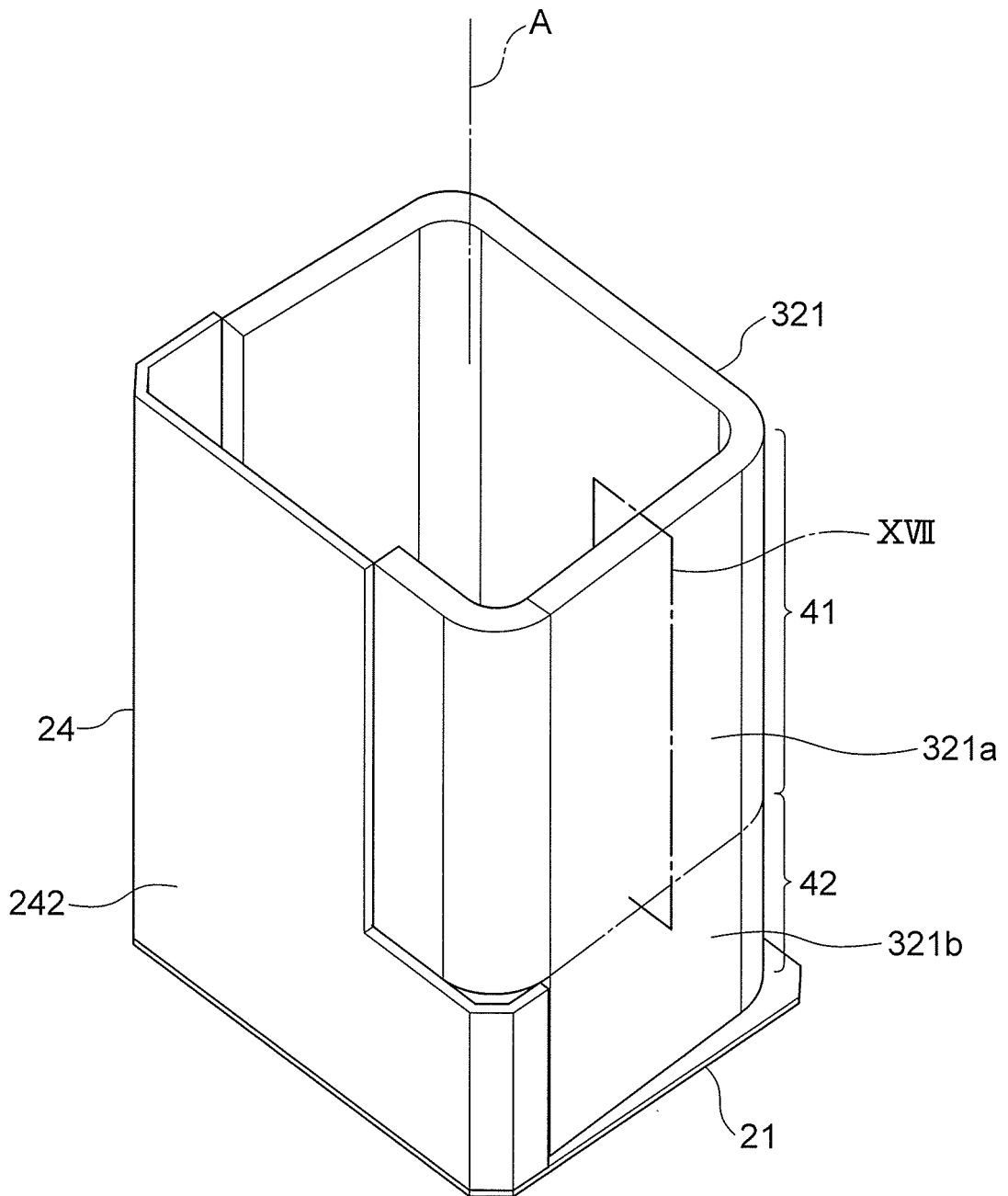

FIG. 17

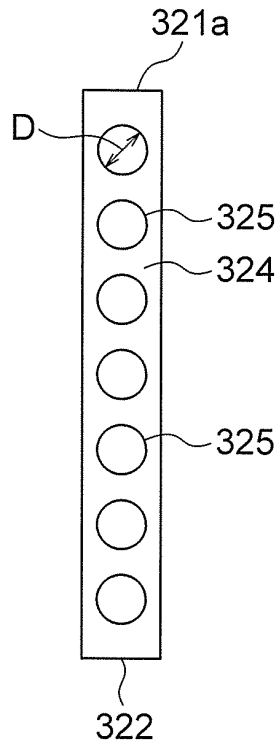

FIG. 18

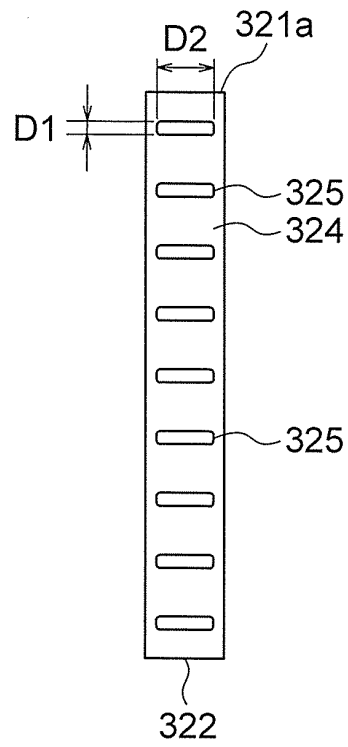

FIG. 19

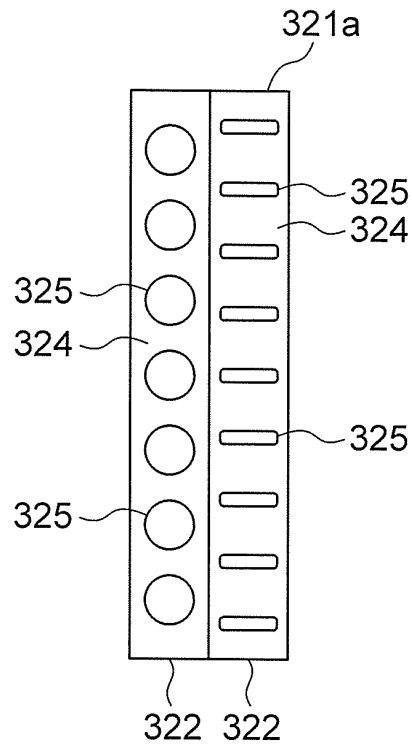

FIG. 20

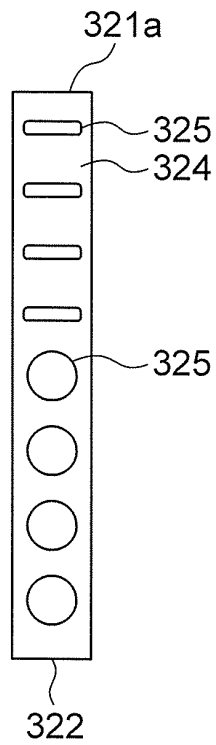

FIG. 21

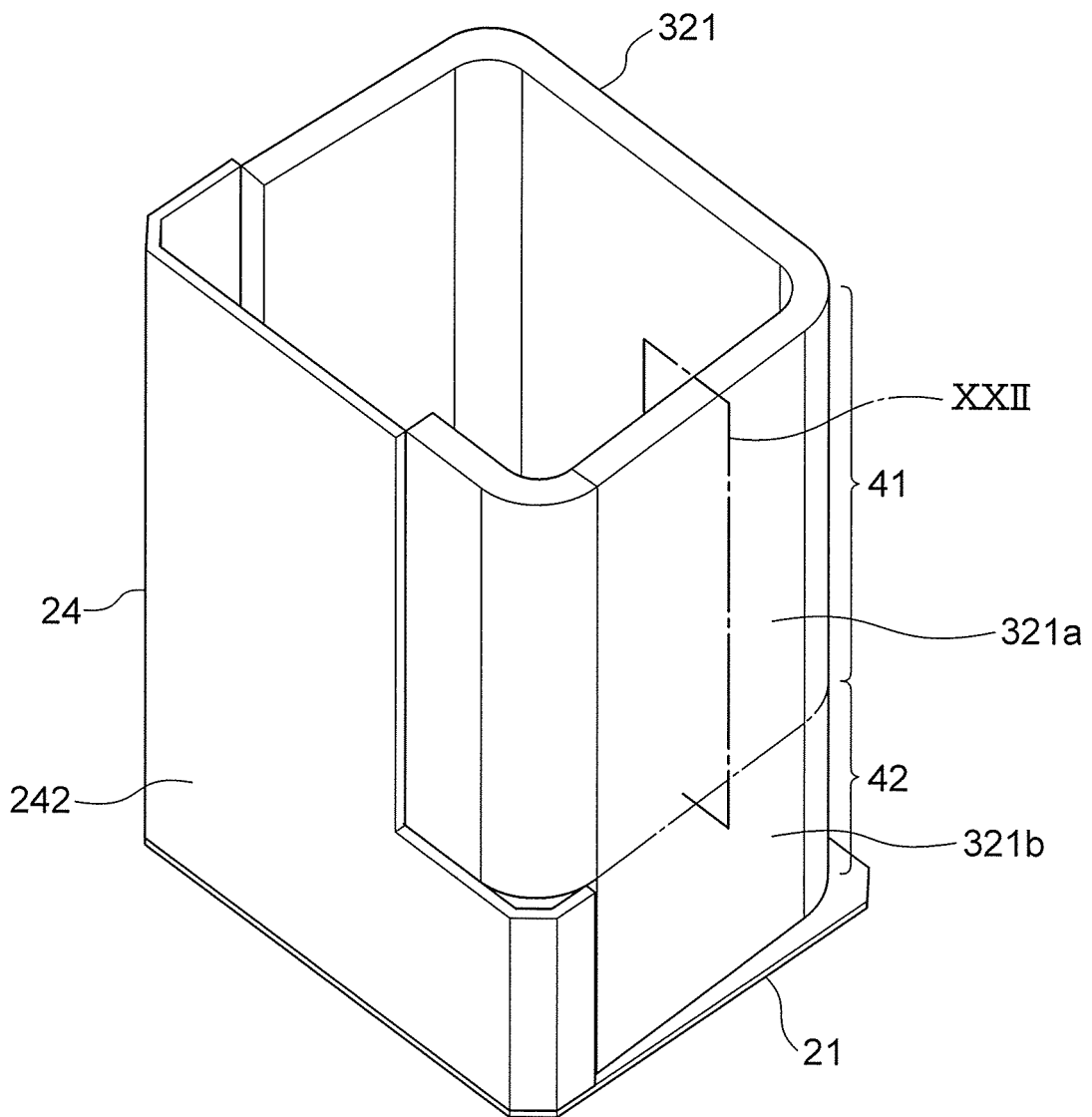

FIG. 22

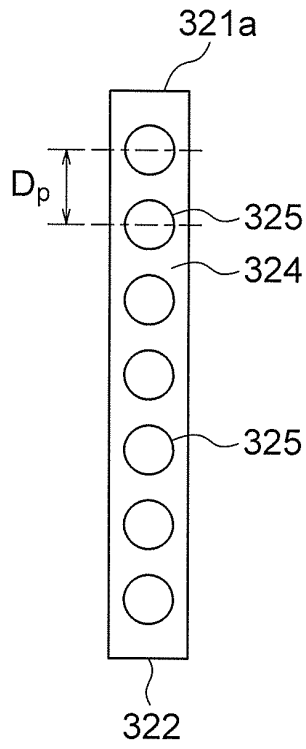

FIG. 23

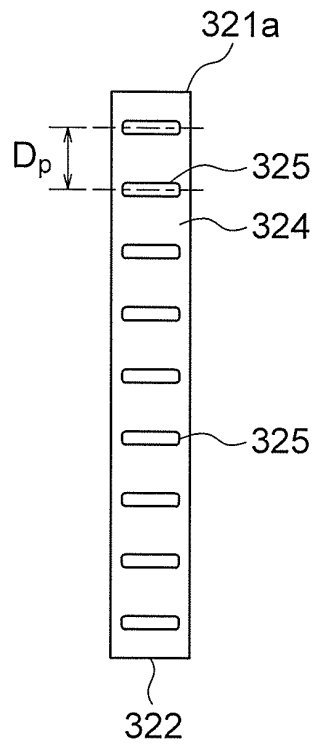

FIG. 24

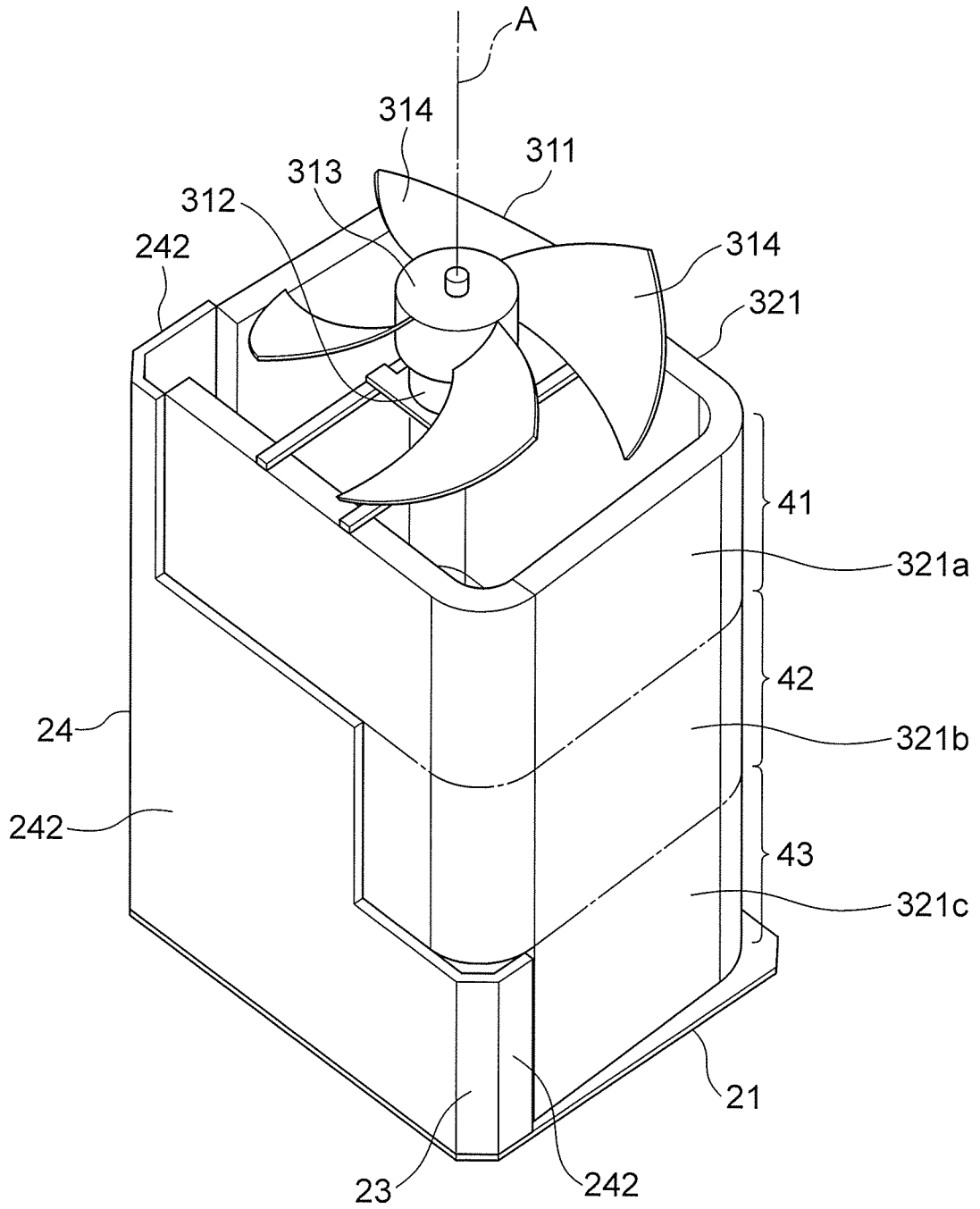

FIG. 25

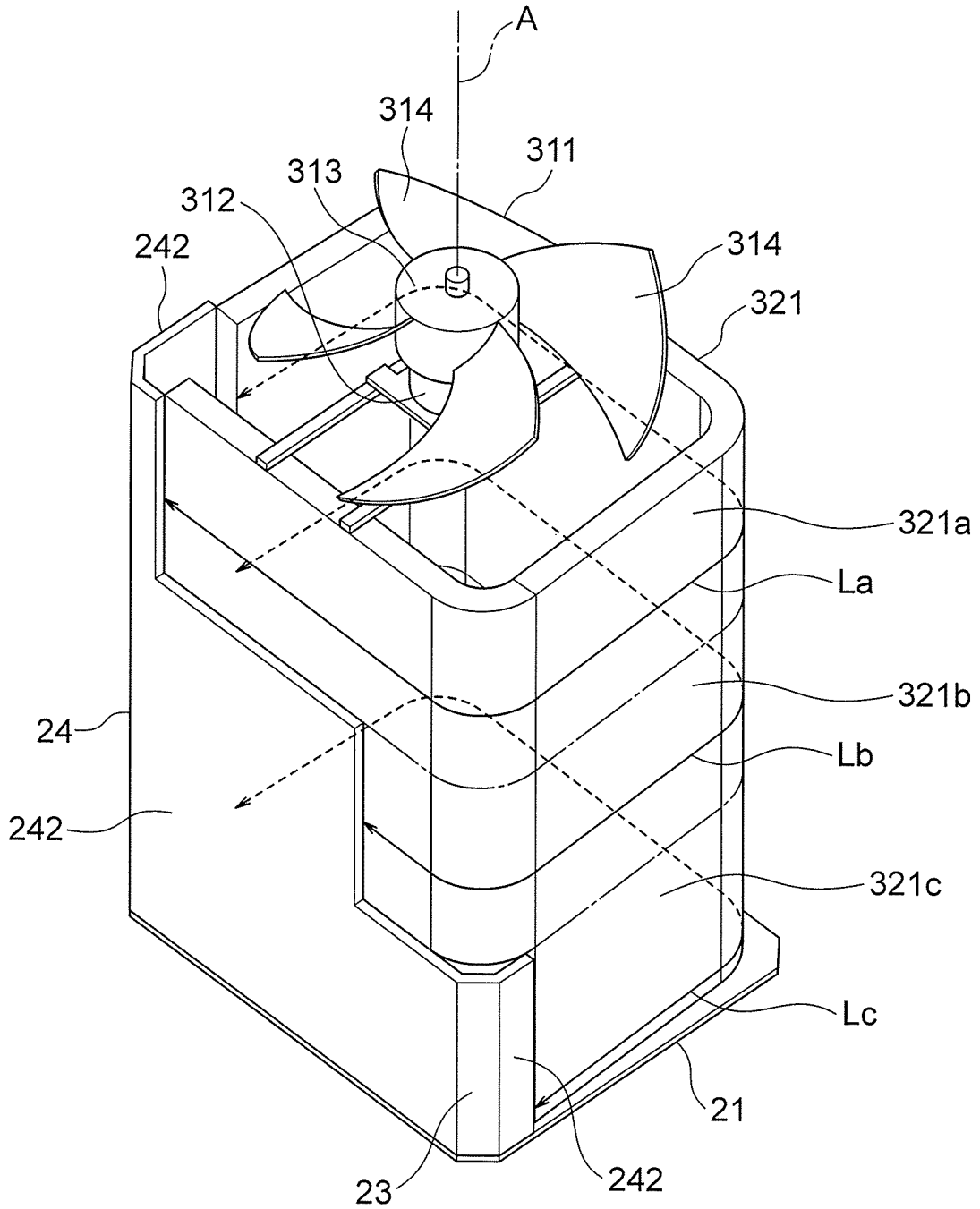

FIG. 26

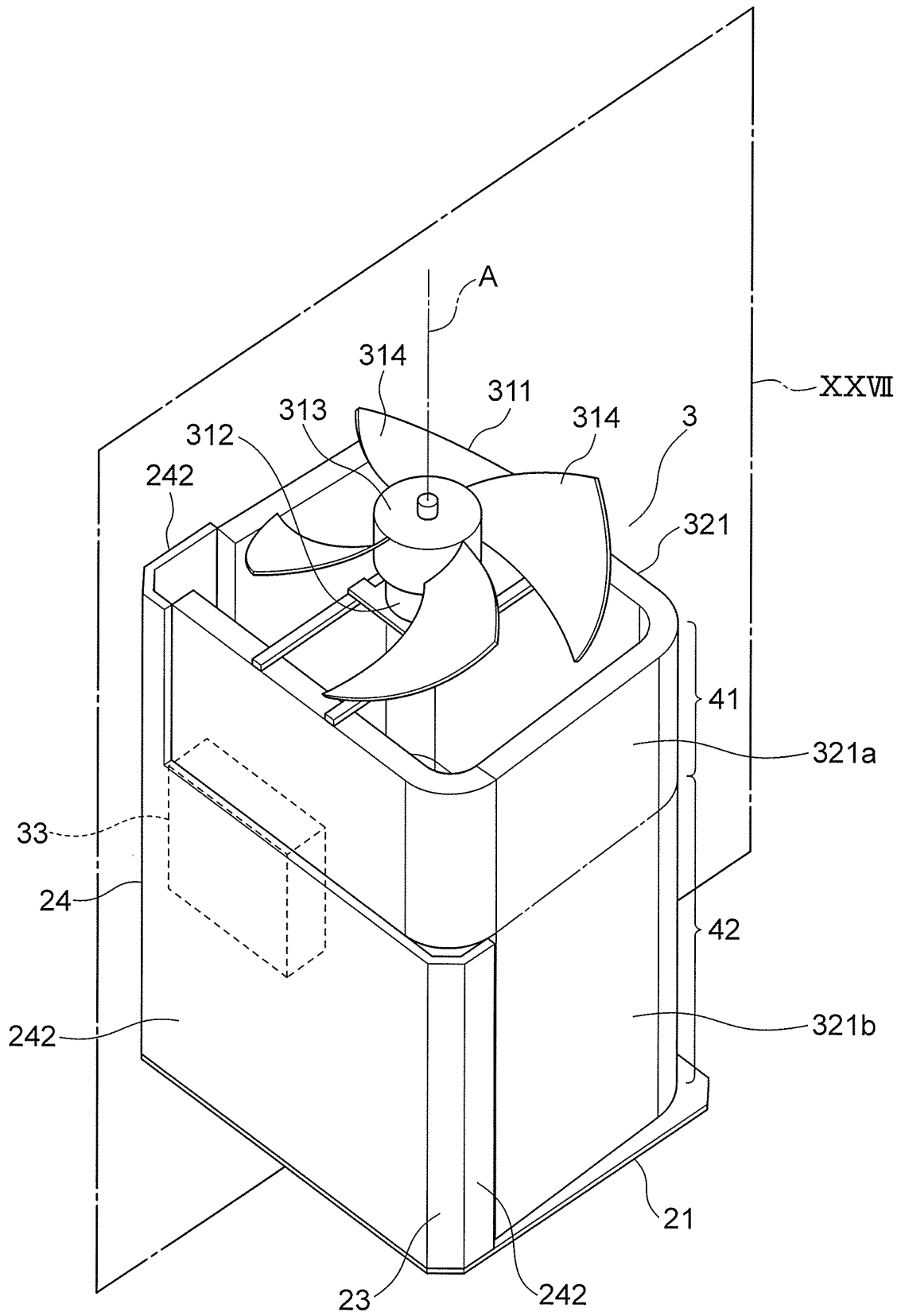

FIG. 27

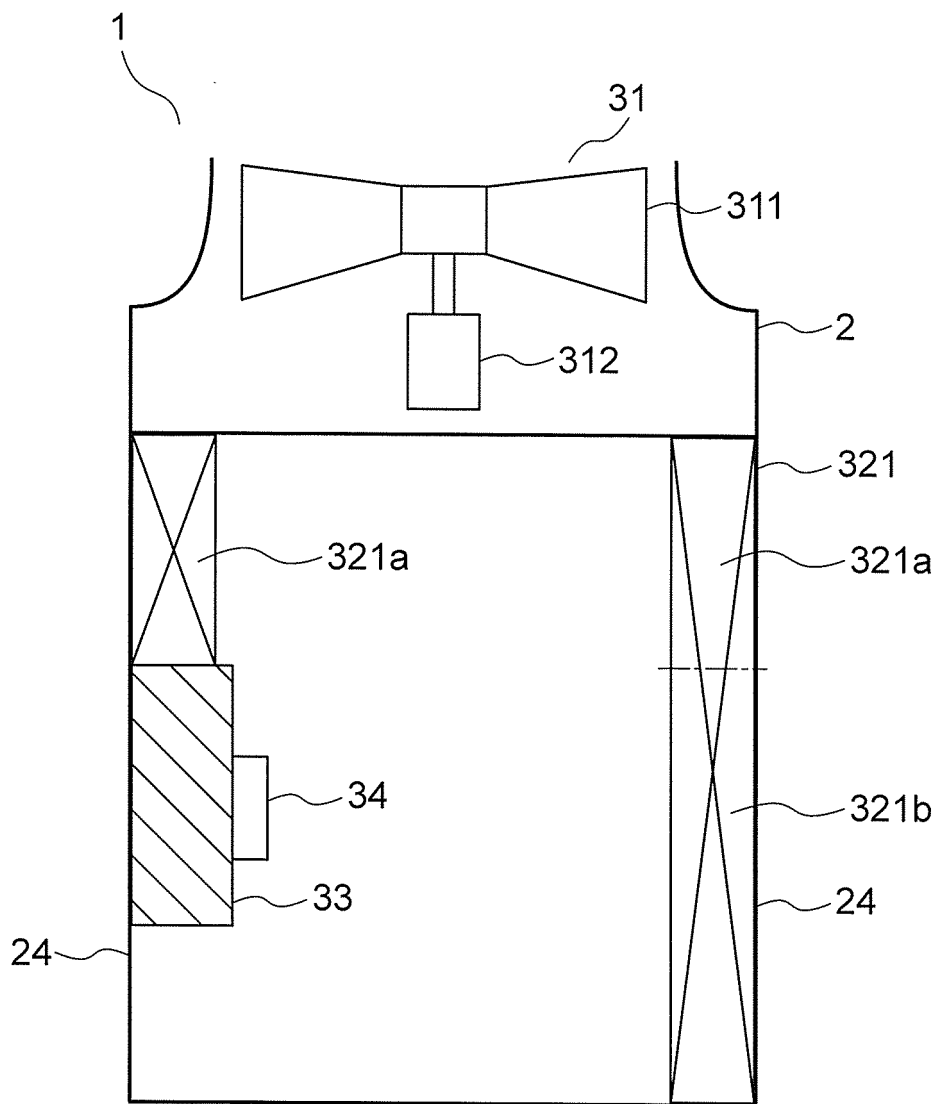

FIG. 28

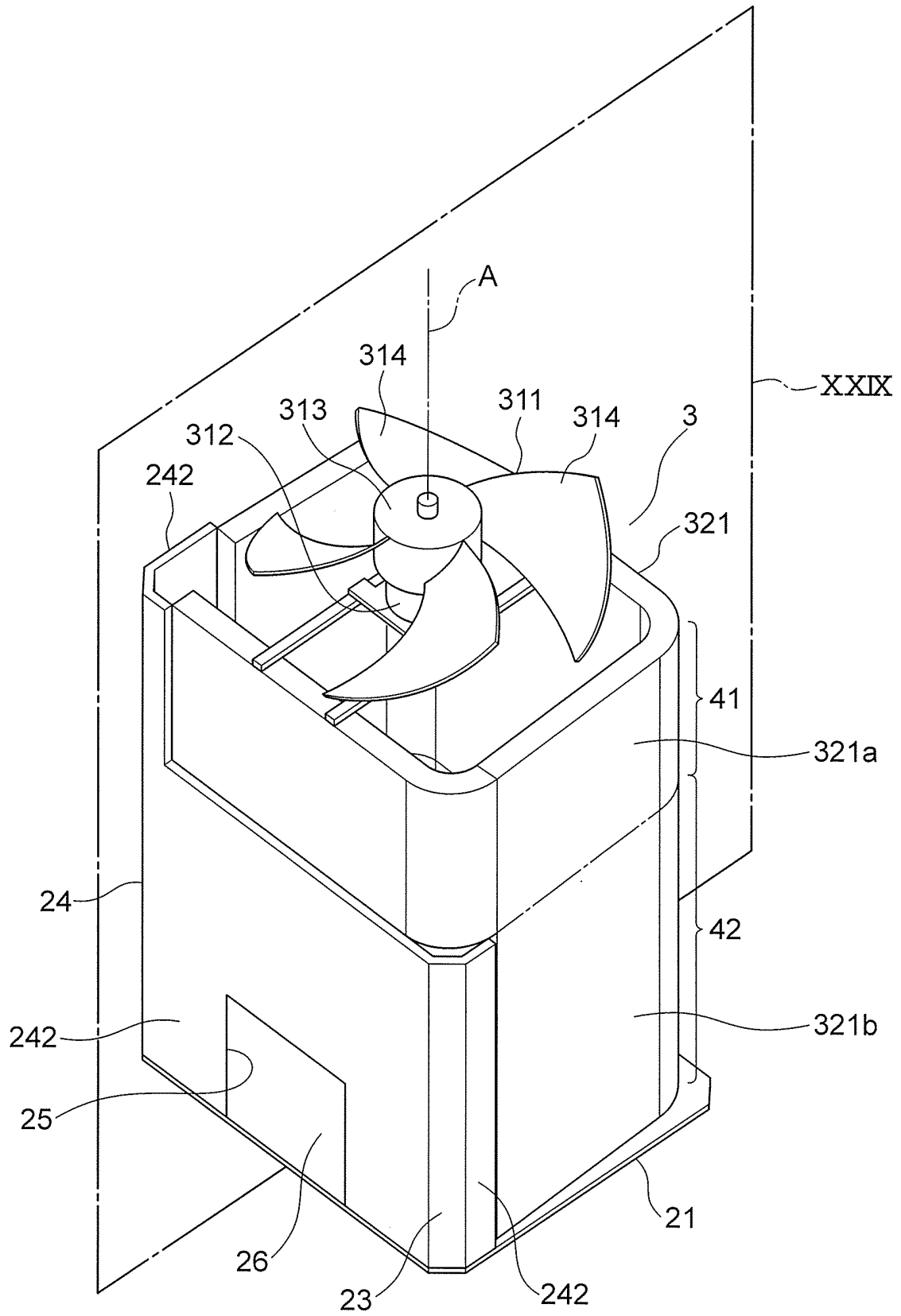
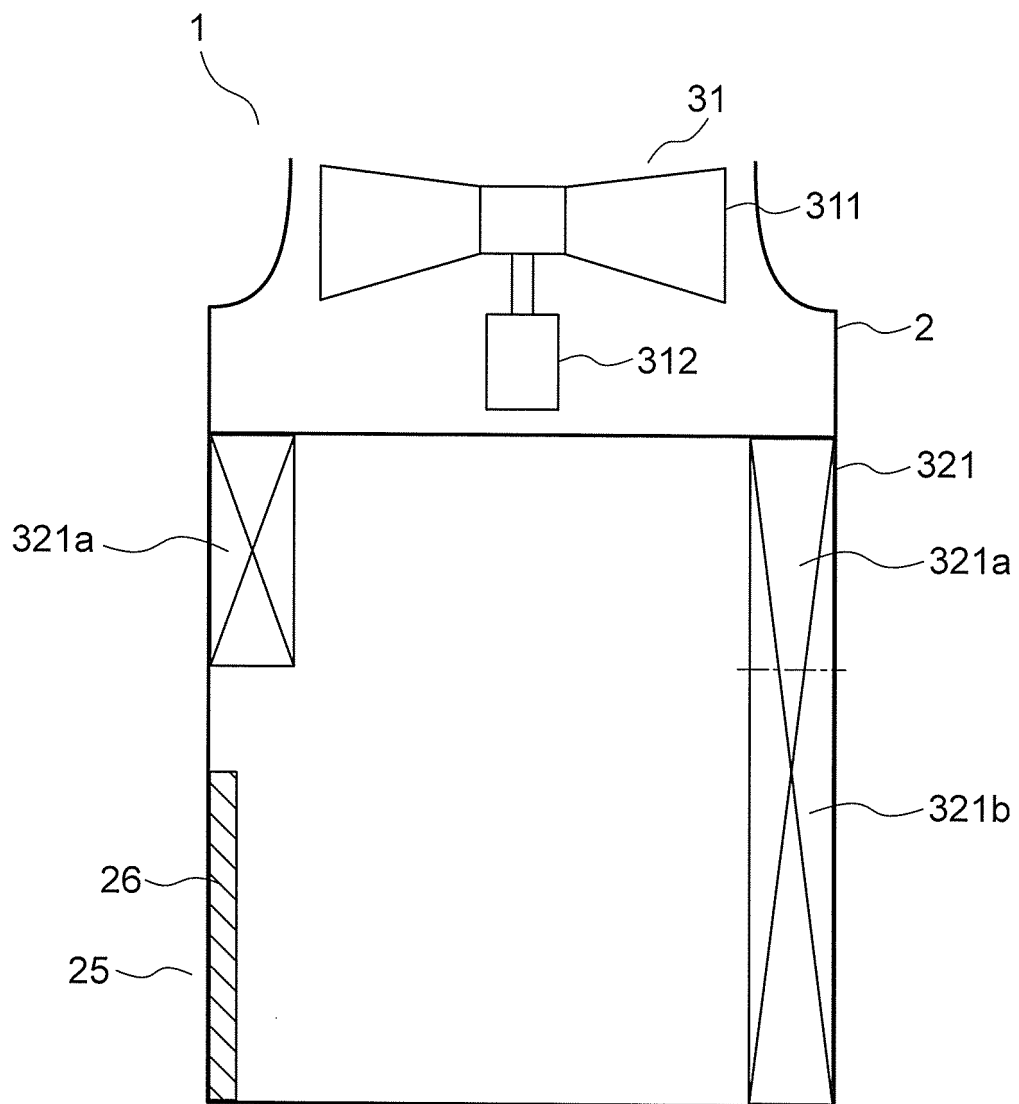

FIG. 29



**REFERENCES CITED IN THE DESCRIPTION**

*This list of references cited by the applicant is for the reader's convenience only. It does not form part of the European patent document. Even though great care has been taken in compiling the references, errors or omissions cannot be excluded and the EPO disclaims all liability in this regard.*

**Patent documents cited in the description**

- JP 2003254565 B [0004]
- JP 2003279076 B [0004]
- WO 2014024221 A [0004]
- JP 2006153332 A [0005]
- JP 2006071162 A [0005]
- JP 4116384 A [0005]
- JP 2005249255 A [0005]