

(19) World Intellectual Property Organization
International Bureau



(43) International Publication Date
31 December 2008 (31.12.2008)

PCT

(10) International Publication Number
WO 2009/000020 A1

(51) International Patent Classification:
B21D 41/02 (2006.01)

(21) International Application Number:
PCT/AU2008/000900

(22) International Filing Date: 20 June 2008 (20.06.2008)

(25) Filing Language: English

(26) Publication Language: English

(30) Priority Data:
2007903382 22 June 2007 (22.06.2007) AU

(71) Applicants and

(72) Inventors: **VANOPYNEN, Adam** [AU/AU]; 97 Willeroo Drive, Windsor Downs, NSW 2756 (AU). **VANOPYNEN, Lambert** [AU/AU]; 97 Willeroo Drive, Windsor Downs, NSW 2756 (AU).

(74) Agent: **GRIFFITH HACK**; Level 29, Northpoint, 100 Miller Street, North Sydney, NSW 2060 (AU).

(81) Designated States (unless otherwise indicated, for every kind of national protection available): AE, AG, AL, AM, AO, AT, AU, AZ, BA, BB, BG, BH, BR, BW, BY, BZ, CA, CH, CN, CO, CR, CU, CZ, DE, DK, DM, DO, DZ, EC, EE, EG, ES, FI, GB, GD, GE, GH, GM, GT, HN, HR, HU, ID, IL, IN, IS, JP, KE, KG, KM, KN, KP, KR, KZ, LA, LC, LK, LR, LS, LT, LU, LY, MA, MD, ME, MG, MK, MN, MW, MX, MY, MZ, NA, NG, NI, NO, NZ, OM, PG, PH, PL, PT, RO, RS, RU, SC, SD, SE, SG, SK, SL, SM, SV, SY, TJ, TM, TN, TR, TT, TZ, UA, UG, US, UZ, VC, VN, ZA, ZM, ZW.

(84) Designated States (unless otherwise indicated, for every kind of regional protection available): ARIPO (BW, GH, GM, KE, LS, MW, MZ, NA, SD, SL, SZ, TZ, UG, ZM, ZW), Eurasian (AM, AZ, BY, KG, KZ, MD, RU, TJ, TM), European (AT, BE, BG, CH, CY, CZ, DE, DK, EE, ES, FI, FR, GB, GR, HR, HU, IE, IS, IT, LT, LU, LV, MC, MT, NL, NO, PL, PT, RO, SE, SI, SK, TR), OAPI (BF, BJ, CF, CG, CI, CM, GA, GN, GQ, GW, ML, MR, NE, SN, TD, TG).

Published:
— with international search report

(54) Title: AN EXTENSION FOR A PIPE EXPANDER

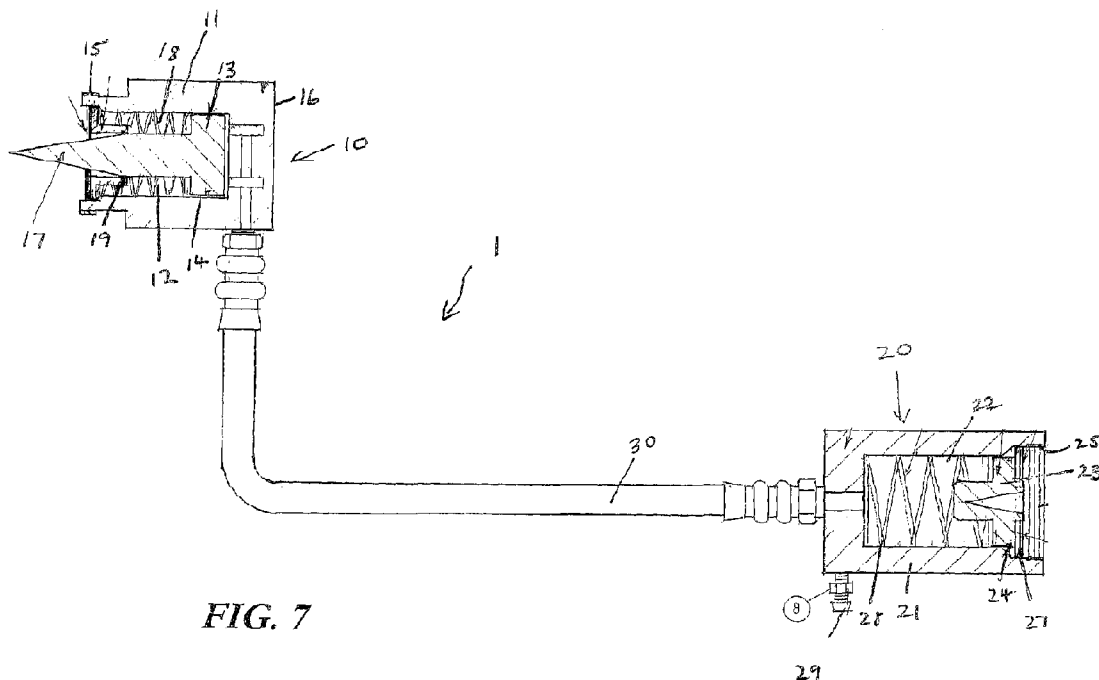

FIG. 7

(57) Abstract: An assembly for actuating a pipe expander, the assembly comprising a first actuator, arranged to engage a pipe expander head and actuate the same a second actuator, spaced apart from the first actuator and operatively engaged therewith such that operation of the second actuator effects operation of the first actuator to actuate the pipe expander head.

WO 2009/000020 A1

AN EXTENSION FOR A PIPE EXPANDER

Technical Field

This invention relates to pipe expanders.

5

Background to the Invention

When joining lengths of pipe, a tool known as a pipe expander is utilised to enlarge the diameter of the ends of one of the pipes to be joined. The pipe expander takes the form of a main body portion and a number of interchangeable expander heads to suit pipes of various diameters. The main body portion includes two large handles which are squeezed together to effect movement of an internal mechanism which in turn acts to cause movement of the expander head which is screw fitted to the main body portion. The expander head is tapered. Upon insertion into the a pipe, the expander head is pushed inward along the pipe by mechanical means such as a shaft. This moves the expander head into the end of the pipe to be expanded. The tapered shape of the expander head means the pipe is forced outwardly in the axial direction. The steel or other pipe is thus expanded.

When working in confined areas, such as near to a wall or floor or on a building site, it is sometimes difficult, or impossible, to gain access to the pipe in order to bring the expander head into engagement with the pipe end to be enlarged.

Summary of the Invention

In a first aspect, disclosed is an assembly for actuating a pipe expander, the assembly comprising a first actuator, arranged to engage a pipe expander head and actuate the same; and a second actuator, spaced apart from the first actuator and operatively engaged therewith such that operation of the second actuator effects operation of the first actuator to actuate the pipe expander head.

In one form the first actuator and second actuator are connected by a conduit. In one form the first actuator and second actuator are connected by a fluid tight conduit. In one form the fluid tight conduit is flexible.

In one form the first actuator comprises a first piston located within a first cylinder and adapted such that a movement of the first piston with respect to the first cylinder actuates the pipe expander head.

- 2 -

In one form the second actuator comprises a second piston located within a second cylinder.

5 In one form the first actuator comprises a first piston located within a first cylinder and adapted such that a movement of the first piston with respect to the first cylinder actuates the pipe expander head and the second actuator comprises a second piston located within a second cylinder and wherein the first actuator and second actuator are operatively engaged such that movement of the second piston with respect to the second cylinder effects movement of the first piston with respect to the first
10 cylinder.

In one form the second actuator is adapted to operatively engage with a pipe expander body such that actuation of the pipe expander causes movement of the second piston with respect to the second cylinder.
15

In one form the first piston is moveable between a retracted position in which it is contained in the cylinder and an extended position in which it extends beyond the cylinder. In one form the first piston actuates the pipe expander head when in the extended position.
20

It can be seen that use of the assembly to actuate a pipe expander allows a user to expand a pipe which is in a difficult position while remaining some distance from the pipe. This allows for use of a pipe expander in difficult spaces with limited access without requiring significant damage to the structures in which the pipes are positioned.
25

In a second aspect, disclosed is an extension for a pipe expander, the extension including a first actuator arranged to receive a pipe expander head, the first actuator including a first chamber and piston; a second actuator arranged to fit to a pipe expander, the second actuator including a second chamber and piston; and a fluid tight conduit which joins the first and second chambers.
30

In one form the conduit is flexible.

In a third aspect, disclosed is a method of using a pipe expander comprising
35 engaging the pipe expander head with a first piston and cylinder assembly such that movement of the first piston with respect to the first cylinder actuates the pipe expander head and initiating movement of the first piston with respect to the first cylinder.

In one form the step of initiating movement of the first piston with respect to the first cylinder comprises initiating movement of a second piston with respect to a second cylinder, the second piston and second cylinder being part of a second piston and cylinder assembly which is in fluid communication with the first piston and cylinder assembly.

In one form the step of initiating movement of the second piston with respect to the second cylinder comprises engaging the second piston and cylinder assembly with a pipe expander such that actuation of the pipe expander causes movement of the second piston with respect to the second cylinder; and actuating the pipe expander.

Brief Description of the Drawings

An embodiment of the present invention will now be described, by way of example only, with reference to the accompanying drawings, in which:

Figure 1 is a side view of the first actuator of an extension for a pipe expander according to one embodiment of the invention;

Figure 2 is a side view of the second actuator of an extension for a pipe expander for use with the first actuator shown in figure 1;

Figure 3 is a cross sectional view of the actuator of figure 1 in an intermediate retracted position;

Figure 4 is a cross sectional view of the actuator of figure 2 in an intermediate position;

Figure 5 is a cross sectional view of the actuator of figure 1 in the extended position; and

Figure 6 is a cross sectional view of the actuator of figure 2 in the extended position

Figure 7 is a cross sectional view of an extension for a pipe expander according to one embodiment of the invention.

Detailed Description of the Preferred Embodiment

Referring to the Figures, disclosed is an assembly 1 for actuating a pipe expander (not illustrated). The assembly 1 includes a first actuator 10 and a second actuator 20 which are operatively engaged.

The first actuator 10 comprises a housing 11 which defines an internal chamber

- 4 -

12. A piston 13 is positioned within internal chamber 12 and is moveable within internal chamber 12 with respect to the housing. The piston 13 is sealed within internal chamber 12 by O rings 14. Thus internal chamber 12 is closed at one end by the piston 13 and O-rings 14.

5

The piston 13 includes a shuttle pin 17 which extends from the piston 13 in the direction of forward movement of the piston 13 within the housing 11. The shuttle pin 17 extends through an opening 19 in housing 11.

10

The piston 13 is moveable within the housing 11 between a retracted position, as best shown in Figure 7, in which the piston is positioned toward the rear of the chamber 12 and the shuttle pin 17 extends only partially from the opening 19 in the housing 11 and an extended position, as best shown in Figure 5, in which the shuttle pin 17 extends further from the opening 19 in the housing 11. An intermediate position is shown in Figure 3. Piston 13 includes a shuttle pin 17. The piston is biased into its retracted position by return spring 18 which is positioned in internal chamber 12.

15

First actuator 10 is arranged to receive a pipe expander head at threaded portion 15. First actuator 10 further includes a service end cap 16 which is positioned at the end of chamber 12 distal from shuttle pin 17 and is removable to allow for servicing and assembly.

20

Shuttle pin O-ring 19 provides a seal about shuttle pin 17 to seal chamber 12.

25

The second actuator 20 comprises a housing 21 which defines an internal chamber 22. A piston 23 is positioned within internal chamber 22 and is moveable within internal chamber 22 with respect to the housing 21. The piston 23 is sealed within internal chamber 22 by O rings 24. Thus internal chamber 22 is closed at one end by the piston 23 and O-rings 24.

30

Second actuator 20 is arranged to operatively engage with and receive a pipe expander (not illustrated) at threaded portion 25. The pipe expander attaches with second actuator 20 and acts upon piston 23 to initiate movement of piston 23 within chamber 22.

35

Piston 23 is moveable between an actuated position, shown in Figure 6, in which the piston 23 is positioned away from clip 27 and a retracted position as shown in

- 5 -

Figure 7, in which the piston rests against clip 27. The piston 23 is biased into the retracted position by return spring 28 and operates against return spring 28. Clip 27 retains piston 23 inside housing 21 while allowing piston 23 to be contacted from external to the second actuator 20.

5

The assembly 1 further includes hydraulic hose 30 which is in fluid communication with both chamber 12 and chamber 22. As a result chambers 12 and 22 are in fluid connection with one another. Hydraulic fluid fills both chambers 12 and 11 and the hose 30. Hydraulic fluid may be introduced at refill plug 29. Hydraulic hose 30 can be made any suitable length, though hose lengths of 0.2m to 0.5m are particularly suitable.

10

It can be seen that movement of piston 23 within chamber 22 effects a pressure change in the hydraulic fluid within chamber 22. This, in turn, is transferred to effect a pressure change on the hydraulic fluid in chamber 12 and thus to initiate movement of piston 12.

15

The assembly 1 comprising first actuator 10 and second actuator 20 connected by hydraulic hose 30 is used in conjunction with a pipe expander (not illustrated). Second actuator 20 is fitted to a pipe expander by screwing actuator 20 onto the pipe expander at threaded portion 25. Second actuator 20 is designed such that the pipe expander acts on piston 23.

20

An appropriate expander head (not shown) to suit the particular diameter of pipe (not shown) to be expanded is engaged with threaded portion 15 of first actuator 10.

25

When the pipe expander is actuated (for example, by squeezing its handles together), the mechanism of the pipe expander bears against and effects movement of piston 23. This in turn causes pressure to increase in chamber 22 which causes flow of hydraulic fluid through hydraulic hose 30 into chamber 12 to effect a corresponding increase of pressure in chamber 12 and a resultant movement of piston 13 into its extended position. Piston 13 in turn moves shuttle pin 17 which causes actuation of the expander head in the usual manner to deform the end of a pipe to expand the pipe.

30

35

When the handles of the pipe expander are released, the mechanism of the pipe expander retracts. Return springs 18 and 28 then expand to move pistons 13 and 23

back to their retracted positions as shown in figures 3 and 4.

5 Use of the assembly 1 allows first actuator 10 to be brought against the end of a pipe to be expanded when the pipe end is in a position that would otherwise be inaccessible by use of a pipe expander alone, such as a position close to an internal corner, or buried in concrete. The first actuator is then actuated from a distance through hydraulic hose 30. Use of the extension avoids the need, or reduces the need, to make or enlarge holes in floors or walls to gain access to expand a pipe end. The extension thus saves time and effort to effect plumbing repairs and installations.

10

It is to be appreciated that various alterations or additions may be made to the parts previously described without departing from the spirit or ambit of the present invention. While the assembly has been described with respect to a hydraulic actuation, persons skilled in the art would recognise that actuation by electrical or mechanical means would fall within the scope of the claims. The hydraulic hose could be replaced by an electrical conduit while each piston and cylinder could be replaced by mechanically or electrically actuated shuttle pins moving with respect to a housing.

15

Any reference to prior art contained herein is not to be taken as an admission that the information is common general knowledge, unless otherwise indicated.

20

We claim:

1. An assembly for actuating a pipe expander, the assembly comprising:
a first actuator, arranged to engage a pipe expander head and actuate the same;
5 a second actuator, spaced apart from the first actuator and operatively engaged
therewith such that operation of the second actuator effects operation of the first
actuator to actuate the pipe expander head.
2. An assembly for actuating a pipe expander as defined in claim 1, wherein the
10 first actuator and second actuator are connected by a conduit.
3. An assembly for actuating a pipe expander as defined in claim 1 or 2 wherein
the first actuator and second actuator are connected by a fluid tight conduit.
- 15 4. An extension for a pipe expander as defined in claim 3, wherein the fluid tight
conduit is flexible.
5. An extension for a pipe expander as defined in claim 3 or 4, wherein the fluid
tight conduit is a hydraulic hose.
20
6. An assembly for actuating a pipe expander as defined in any one of claims 3
through 5, wherein the fluid tight conduit contains hydraulic fluid and is in fluid
communication with the first and second actuators.
- 25 7. An assembly for actuating a pipe expander as defined in any of the preceding
claims, wherein the first actuator comprises a first piston located within a first cylinder
and adapted such that a movement of the first piston with respect to the first cylinder
actuates the pipe expander head.
- 30 8. An assembly for actuating a pipe expander as defined in any of the preceding
claims, wherein the second actuator comprises a second piston located within a second
cylinder.
9. An assembly for actuating a pipe expander as defined in any of the preceding
35 claims, wherein the first actuator comprises a first piston located within a first cylinder
and adapted such that a movement of the first piston with respect to the first cylinder
actuates the pipe expander head and the second actuator comprises a second piston

located within a second cylinder and wherein the first actuator and second actuator are operatively engaged such that movement of the second piston with respect to the second cylinder effects movement of the first piston with respect to the first cylinder.

- 5 10. An assembly for actuating a pipe expander as defined in claim 9, wherein the second actuator is adapted to operatively engage with a pipe expander such that actuation of the pipe expander causes movement of the second piston with respect to the second cylinder.
- 10 11. An extension for a pipe expander as defined in any of the preceding claims, wherein the first actuator includes a helical thread to receive the pipe expander head.
12. An extension for a pipe expander as defined in claim 9 or 10, wherein the first piston is moveable between a retracted position in which it is contained in the cylinder
15 and an extended position in which it extends beyond the cylinder.
13. An extension for a pipe expander as defined in claim 12, wherein the first piston actuates the pipe expander head when in the extended position.
- 20 14. An extension for a pipe expander as defined in any of claims 9 through 13, wherein the first actuator and second actuator each include a chamber, the chambers being in fluid communication.
15. An extension for a pipe expander, the extension including:
25 a first end arranged to receive a pipe expander head, the first end including a first chamber and piston;
a second end arranged to fit to a pipe expander, the second end including a second chamber and piston; and
a fluid tight conduit which joins the first and second chambers.
- 30 16. An extension according to claim 11 wherein the conduit is flexible.
17. A method of using a pipe expander comprising:
engaging the pipe expander head with a first piston and cylinder assembly such
35 that movement of the first piston with respect to the first cylinder actuates the pipe expander head;
initiating movement of the first piston with respect to the first cylinder.

18. A method of using a pipe expander as defined in claim 17, wherein step of
initiating movement of the first piston with respect to the first cylinder comprises
initiating movement of a second piston with respect to a second cylinder, the second
5 piston and second cylinder being part of a second piston and cylinder assembly which is
in fluid communication with the first piston and cylinder assembly.

19. A method of using a pipe expander as defined in claim 18, wherein the step of
initiating movement of the second piston with respect to the second cylinder comprises;
10 engaging the second piston and cylinder assembly with a pipe expander such
that actuation of the pipe expander causes movement of the second piston with respect
to the second cylinder; and
actuating the pipe expander.

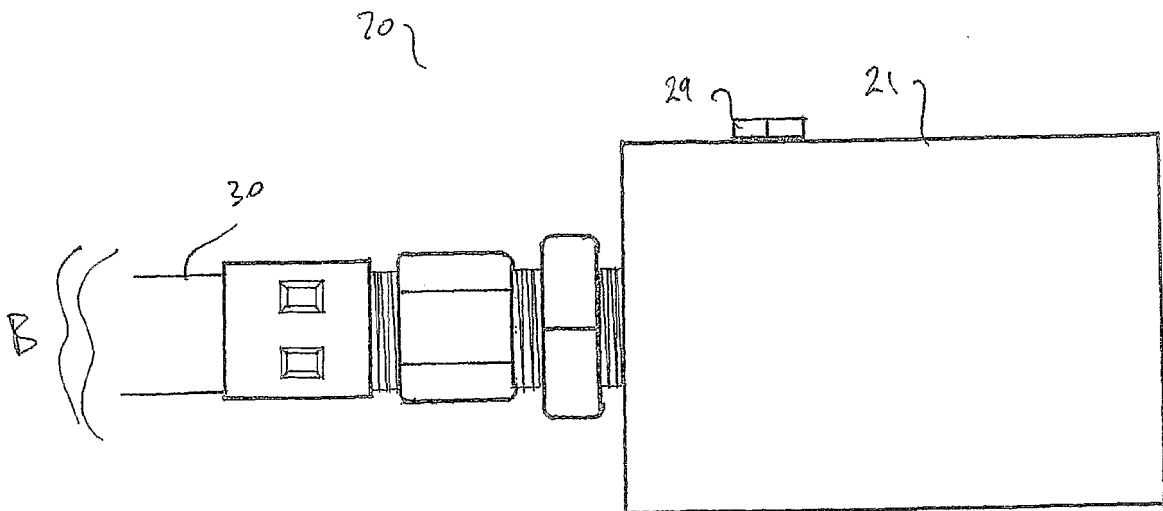
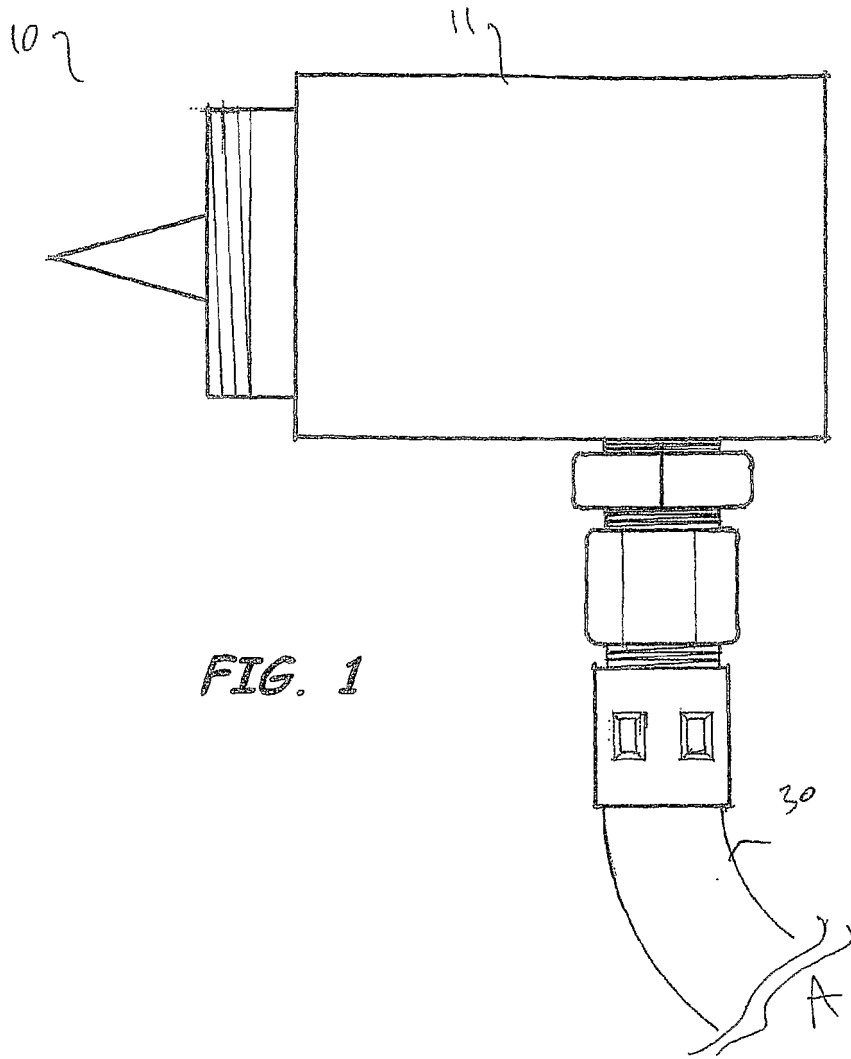

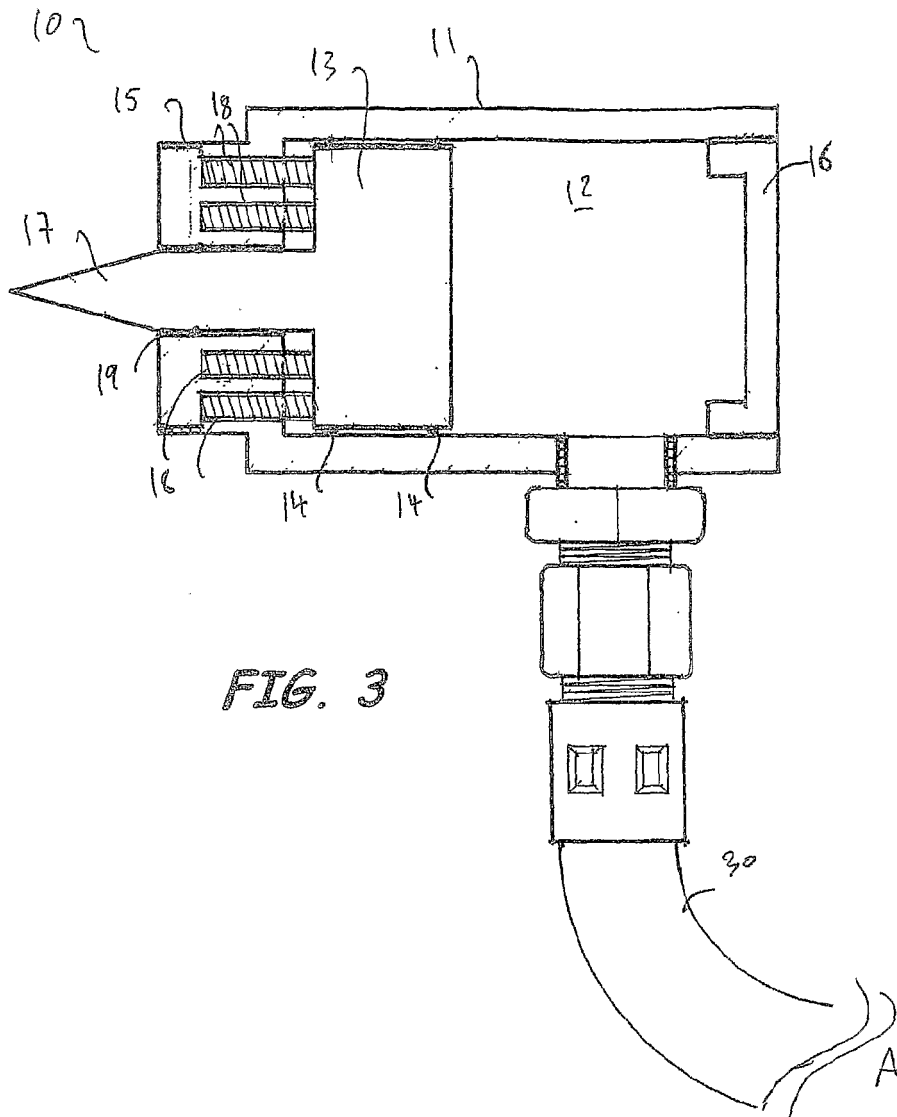

FIG. 3

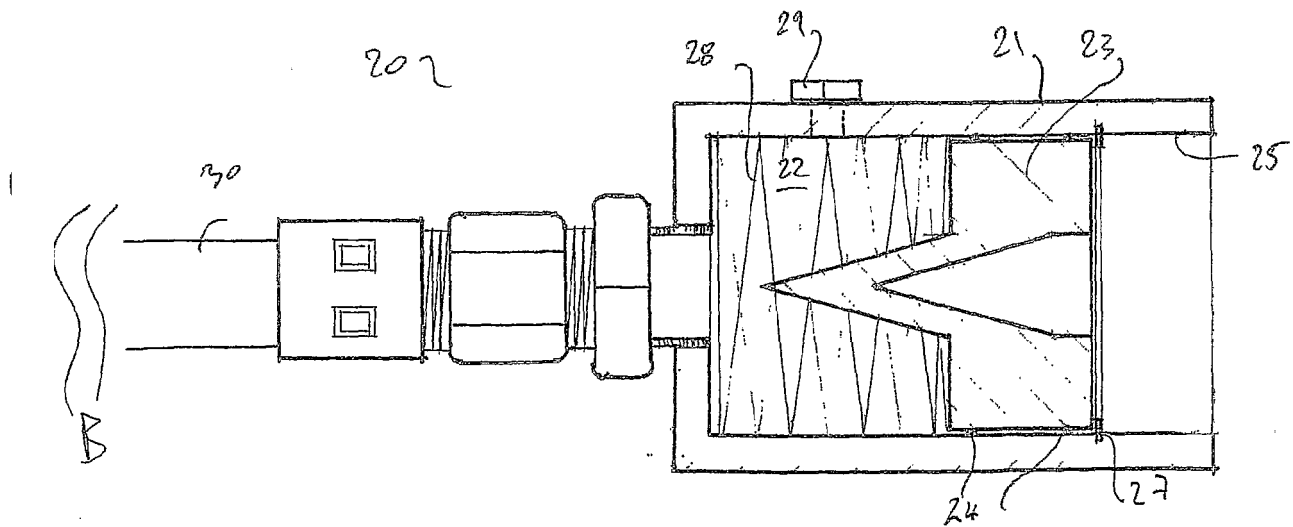

FIG. 4

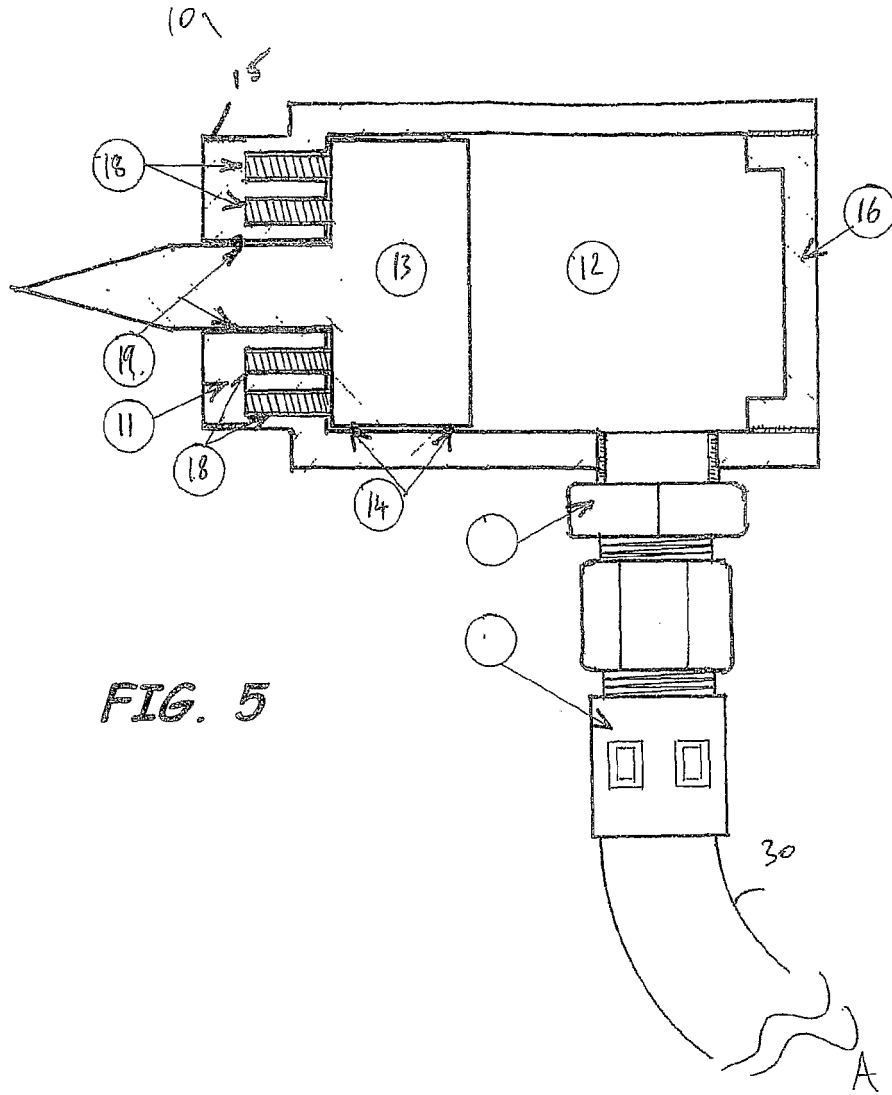

FIG. 5

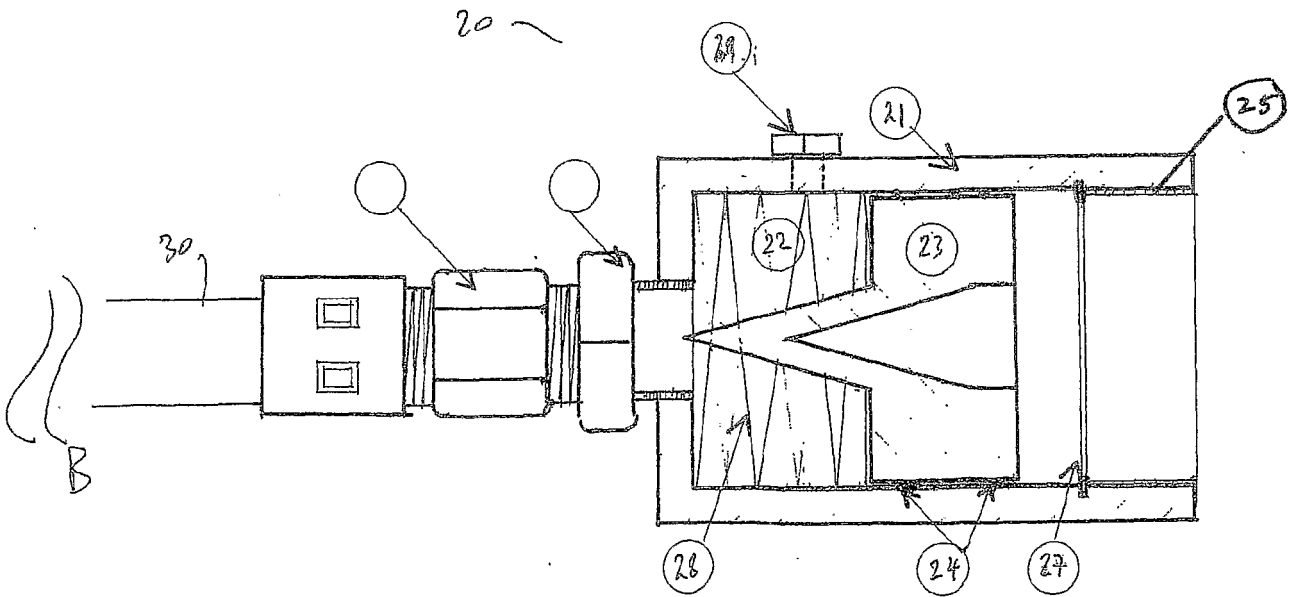

FIG. 6

INTERNATIONAL SEARCH REPORT

International application No.

PCT/AU2008/000900

A. CLASSIFICATION OF SUBJECT MATTER

Int. Cl.

B21D 41/02 (2006.01)

According to International Patent Classification (IPC) or to both national classification and IPC

B. FIELDS SEARCHED

Minimum documentation searched (classification system followed by classification symbols)

Documentation searched other than minimum documentation to the extent that such documents are included in the fields searched

Electronic data base consulted during the international search (name of data base and, where practicable, search terms used)

DWPI, B21D 41/02, 39/10 key words PISTON+, RAM, HYDRAULIC+, PNEUM+, CYLIND+, REMOTE+, MASTER+, SLAV+

C. DOCUMENTS CONSIDERED TO BE RELEVANT

Category*	Citation of document, with indication, where appropriate, of the relevant passages	Relevant to claim No.
X	GB 2392860 A (SMART TOOLS LTD) 17 March 2004 Whole document (please refer to figs 1-5)	17
X	BE 838574 A (ROTHENBERGER & CO G) 28 May 1976 Whole document (please refer to figs 1-4)	17
A	US 4212183 A (MABERY) 15 July 1980 Whole document	1-19

 Further documents are listed in the continuation of Box C See patent family annex

* Special categories of cited documents:		
"A" document defining the general state of the art which is not considered to be of particular relevance	"T" later document published after the international filing date or priority date and not in conflict with the application but cited to understand the principle or theory underlying the invention	
"E" earlier application or patent but published on or after the international filing date	"X" document of particular relevance; the claimed invention cannot be considered novel or cannot be considered to involve an inventive step when the document is taken alone	
"L" document which may throw doubts on priority claim(s) or which is cited to establish the publication date of another citation or other special reason (as specified)	"Y" document of particular relevance; the claimed invention cannot be considered to involve an inventive step when the document is combined with one or more other such documents, such combination being obvious to a person skilled in the art	
"O" document referring to an oral disclosure, use, exhibition or other means	"&" document member of the same patent family	
"P" document published prior to the international filing date but later than the priority date claimed		

Date of the actual completion of the international search
08 July 2008Date of mailing of the international search report
14 JUL 2008Name and mailing address of the ISA/AU
AUSTRALIAN PATENT OFFICE
PO BOX 200, WODEN ACT 2606, AUSTRALIA
E-mail address: pct@ipaaustralia.gov.au
Facsimile No. +61 2 6283 7999Authorized officer
SARAVANAMUTHU PONNAMPALAM
AUSTRALIAN PATENT OFFICE
(ISO 9001 Quality Certified Service)
Telephone No : (02) 6283 2070

INTERNATIONAL SEARCH REPORT

Information on patent family members

International application No.

PCT/AU2008/000900

This Annex lists the known "A" publication level patent family members relating to the patent documents cited in the above-mentioned international search report. The Australian Patent Office is in no way liable for these particulars which are merely given for the purpose of information.

Patent Document Cited in Search Report		Patent Family Member					
GB	2392860	AU	2003267619	US	7353682	US	2006144116
		WO	2004024365				
BE	838574	AU	10963/76	DE	2505915	FR	2300638
		GB	1485099	JP	51106675	US	4034591
US	4212183	CA	1122446	EP	0014245	ES	486590
		IN	152259	JP	55081031		
<p>Due to data integration issues this family listing may not include 10 digit Australian applications filed since May 2001.</p> <p style="text-align: right;">END OF ANNEX</p>							