



(12) **United States Design Patent**
Messina

(10) **Patent No.:** **US D584,520 S**
(45) **Date of Patent:** **** Jan. 13, 2009**

(54) **FOLDABLE DECKCHAIR**

(76) Inventor: **Daniel Messina**, Chemin Perdu 2, La
Chaux-de-Fonds (CH) 2300

(**) Term: **14 Years**

(21) Appl. No.: **29/302,497**

(22) Filed: **Jan. 17, 2008**

(30) **Foreign Application Priority Data**

Jul. 18, 2007 (EM) 000760483

(51) **LOC (9) Cl.** **06-01**

(52) **U.S. Cl.** **D6/361**

(58) **Field of Classification Search** D6/361,
D6/334-335, 348, 344, 365, 367, 368, 369,
D6/374-376, 500-502; 297/55, 39, 271.6,
297/294, 452.14, 445.1, 448.1, 452.2, 353;
5/620, 627

See application file for complete search history.

(56) **References Cited**

U.S. PATENT DOCUMENTS

D278,392 S *	4/1985	Bayly	D6/361
D285,871 S *	9/1986	Stenwall	D6/336
D296,849 S *	7/1988	Cronk	D6/361
D316,490 S *	4/1991	Martin	D6/361
5,094,509 A *	3/1992	Bolzacchini	297/377
D360,081 S *	7/1995	Westerburgen	D6/361
D388,257 S *	12/1997	Grosfillex	D6/361
D414,049 S *	9/1999	van Rhienen	D6/361
D429,909 S *	8/2000	Hoisl	D6/361
D509,967 S *	9/2005	Nardi	D6/361
D515,324 S *	2/2006	Grosfillex	D6/361
D517,333 S *	3/2006	Grosfillex	D6/361
D565,851 S *	4/2008	Marin	D6/361

* cited by examiner

Primary Examiner—Caron Veynar

Assistant Examiner—Abraham Bahta

(74) *Attorney, Agent, or Firm*—Frommer Lawrence & Haug
LLP; Ronald R. Santucci

(57) **CLAIM**

The ornamental design for a foldable deckchair, as shown and described.

DESCRIPTION

FIG. 1 is a front elevation view of the foldable deckchair, showing the present design in the position of use;

FIG. 2 is a right elevation view thereof in the position of use;

FIG. 3 is a left elevation view thereof in the position of use;

FIG. 4 is a rear elevation view thereof in the position of use;

FIG. 5 is a top plan view thereof in the position of use;

FIG. 6 is a bottom plan view thereof in the position of use; and

FIG. 7 is a front perspective view thereof in the position of use;

FIG. 8 is a front elevation view of the folded deckchair, showing the present design in the position of transport;

FIG. 9 is a rear elevation view thereof in the position of transport;

FIG. 10 is a bottom plan view thereof in the position of transport;

FIG. 11 is a top plan view thereof in the position of transport;

FIG. 12 is a right elevation view thereof in the position of transport;

FIG. 13 is a left elevation view thereof in the position of transport; and,

FIG. 14 is a side perspective view thereof in the position of transport.

1 Claim, 5 Drawing Sheets

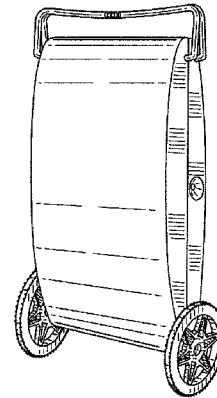
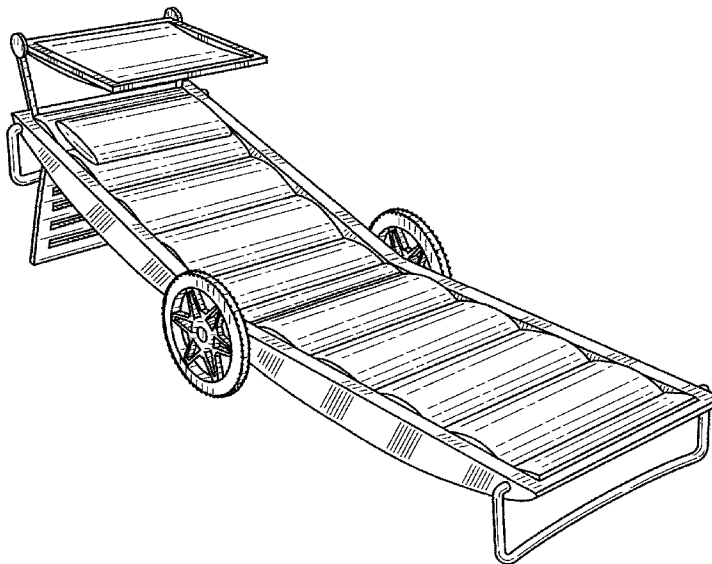

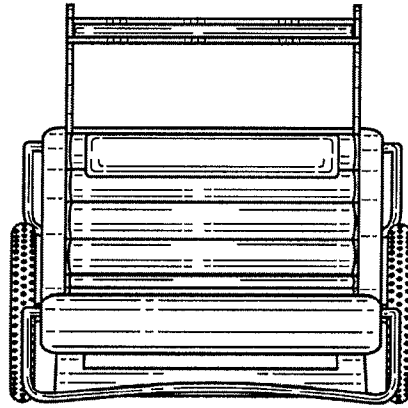

Fig. 1

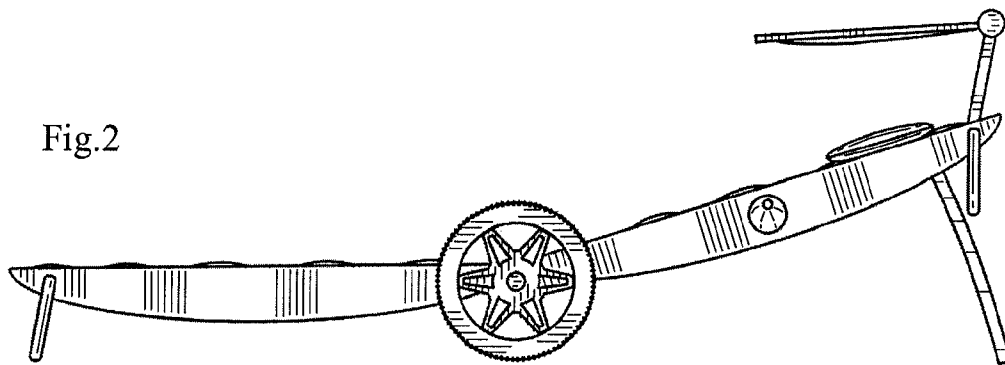

Fig. 2

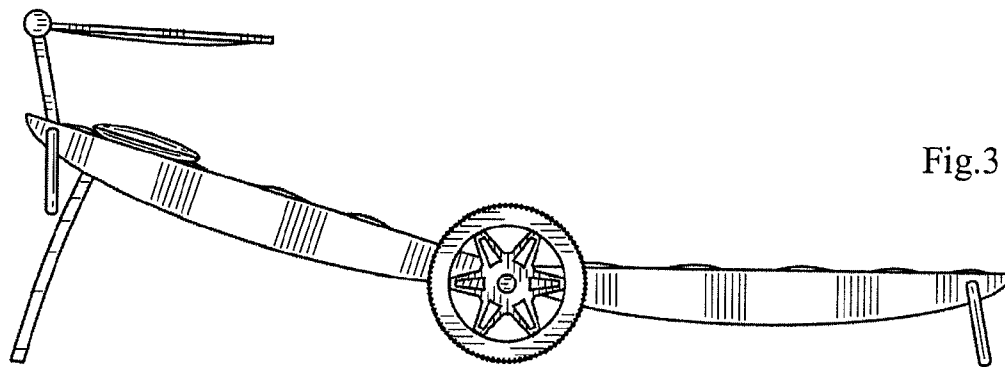

Fig. 3

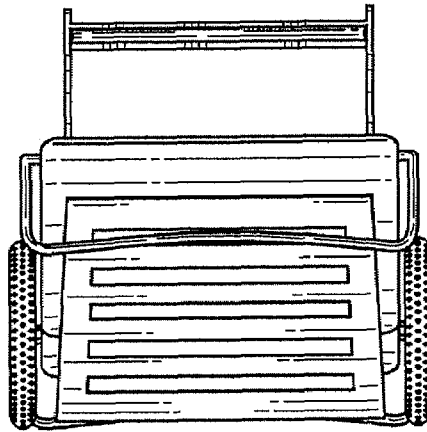

Fig.4

Fig.5

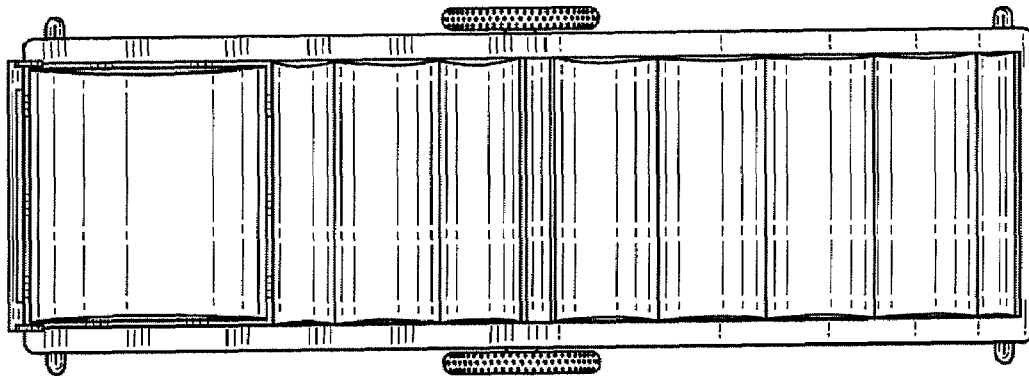

Fig.6

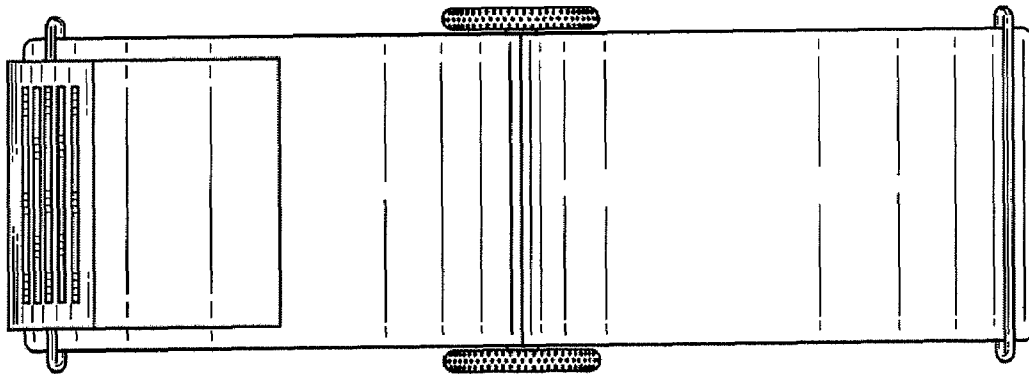

Fig. 7

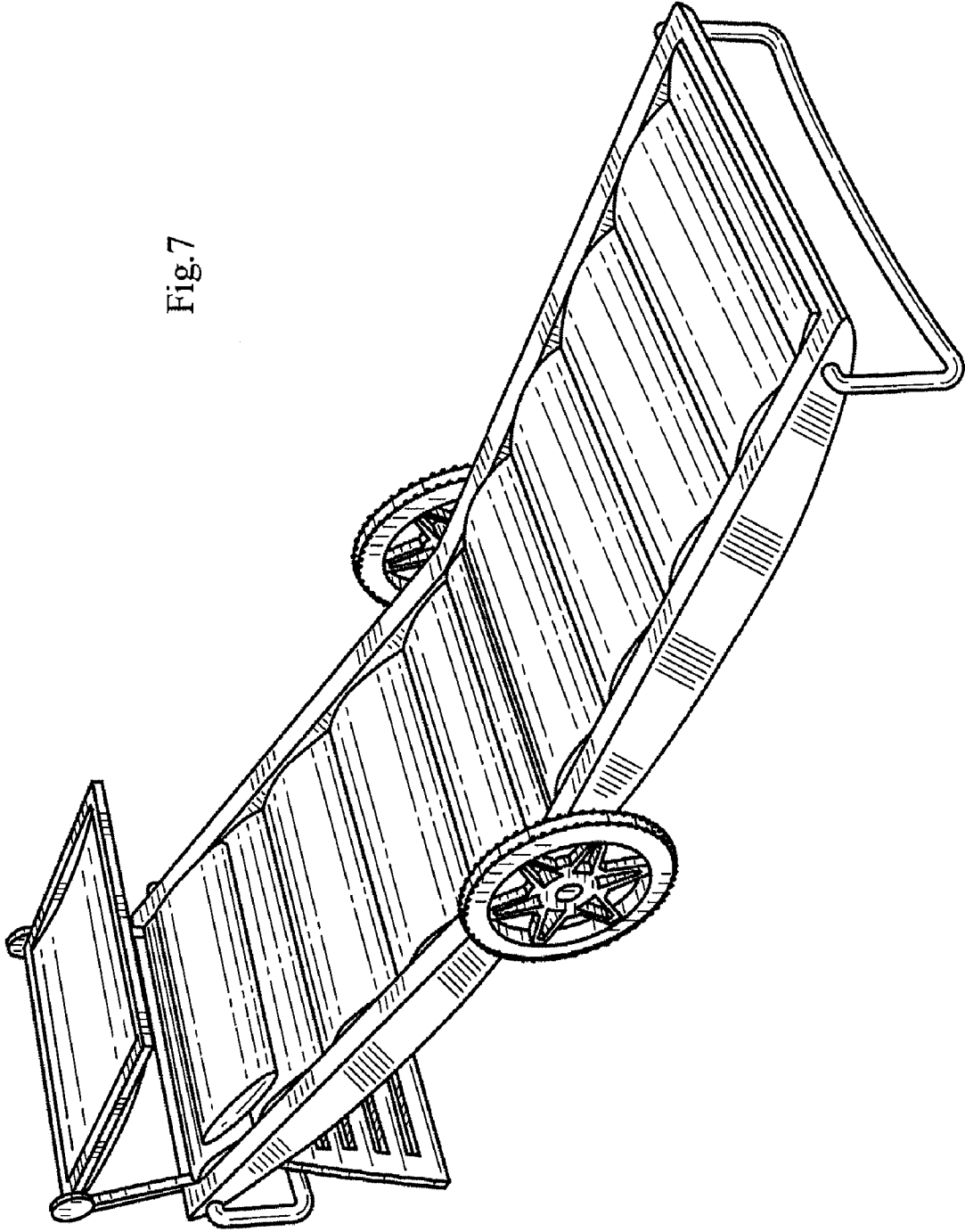

Fig.8

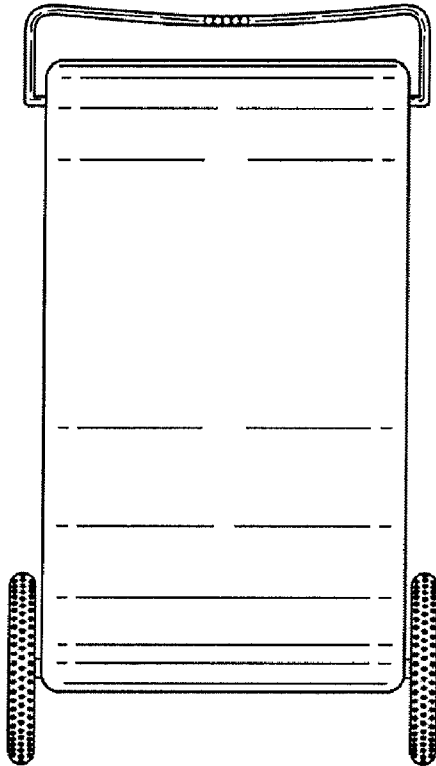

Fig.9

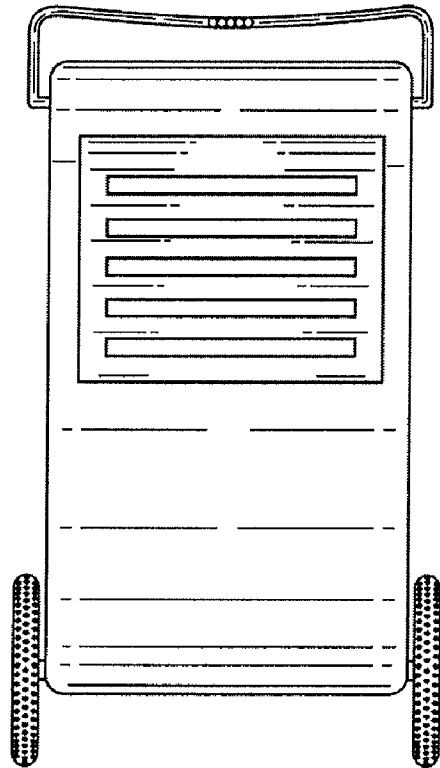

Fig.10

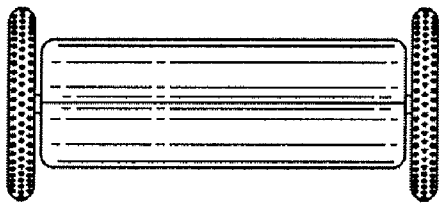

Fig.11

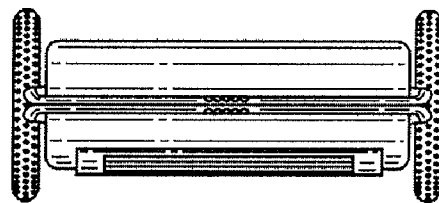

Fig.12

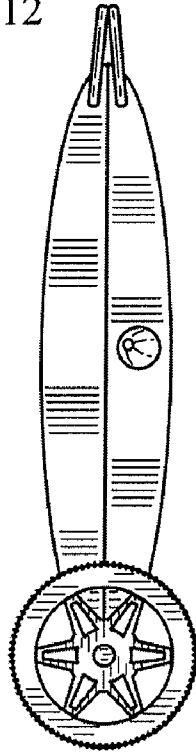

Fig.13

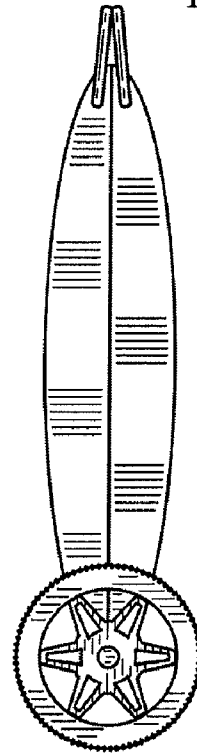

Fig.14

