



(12) **DEMANDE DE BREVET CANADIEN  
CANADIAN PATENT APPLICATION**

(13) **A1**

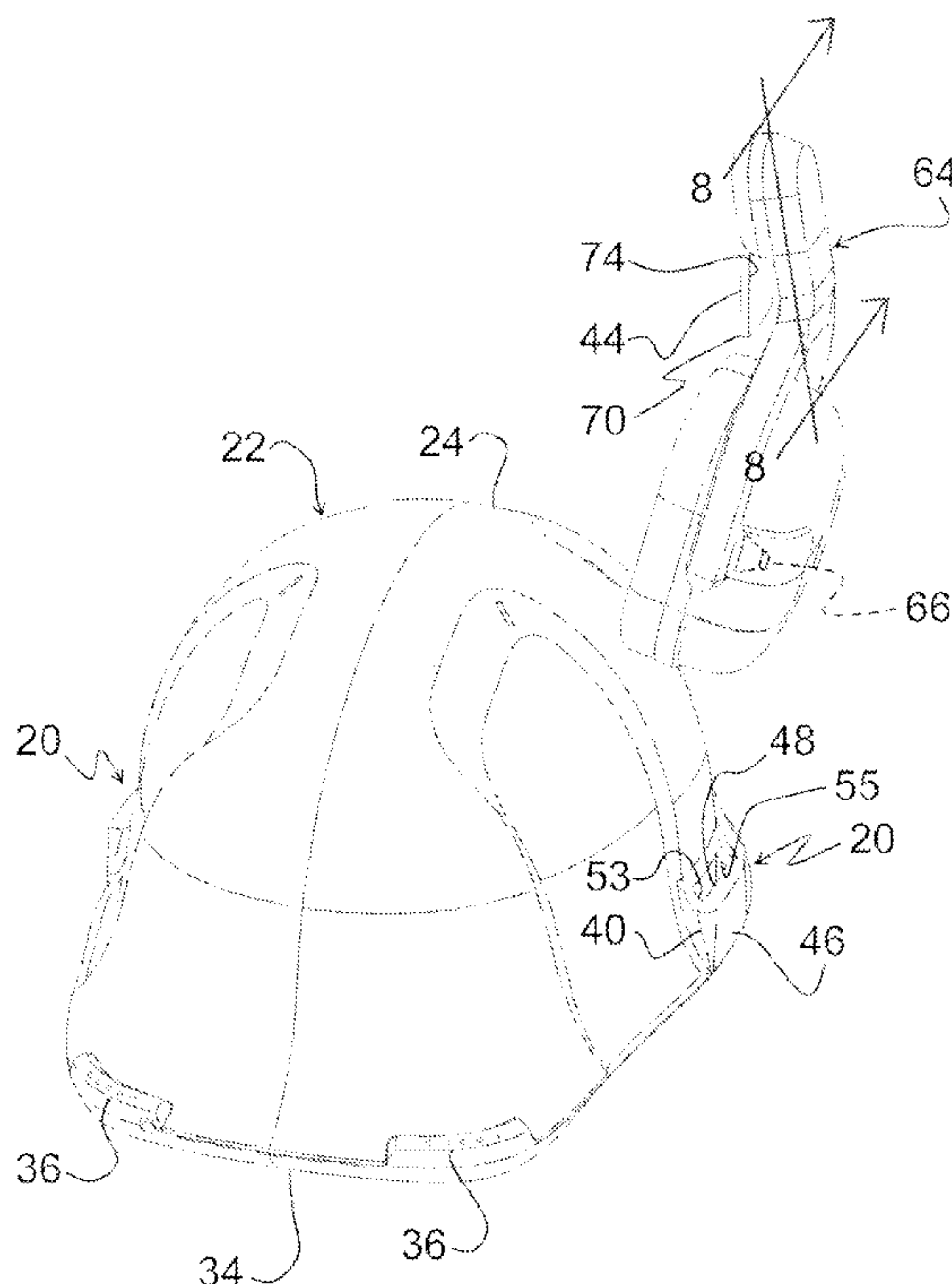
(86) Date de dépôt PCT/PCT Filing Date: 2016/10/10  
 (87) Date publication PCT/PCT Publication Date: 2017/04/27  
 (85) Entrée phase nationale/National Entry: 2018/04/13  
 (86) N° demande PCT/PCT Application No.: US 2016/056264  
 (87) N° publication PCT/PCT Publication No.: 2017/069961  
 (30) Priorités/Priorities: 2015/10/14 (US14/883,157);  
 2016/03/31 (US15/087,972)

(51) Cl.Int./Int.Cl. *A42B 1/24* (2006.01)  
 (71) Demandeur/Applicant:  
 GUARDHAT, INC., US  
 (72) Inventeurs/Inventors:  
 DEY, SAIKAT, US;  
 REEPMAYER, GERRIT, US;  
 SENGUPTA, ANUPAM, US;  
 ZHAVORONKOV, MIKHAIL, US;  
 PERUMAL, SENNI, US;  
 FRIEDMAN, STEVEN, US  
 (74) Agent: RIDOUT & MAYBEE LLP

(54) Titre : ENSEMBLE DE CONNEXION PERMETTANT D'ADJOINDRE UN PERIPHERIQUE A UN DISPOSITIF HOTE PORTABLE

(54) Title: CONNECTION ASSEMBLY FOR ADJOINING A PERIPHERAL WITH A HOST WEARABLE DEVICE

**Figure 5**



(57) **Abrégé/Abstract:**

A connection assembly for adjoining a peripheral with a host wearable device. Embodiment of the assembly can be a hardhat with an accessory connection slot allowing for both mechanical and electrical attachment of various accessories such as earphones, video display, headlamp, welder's face shield.

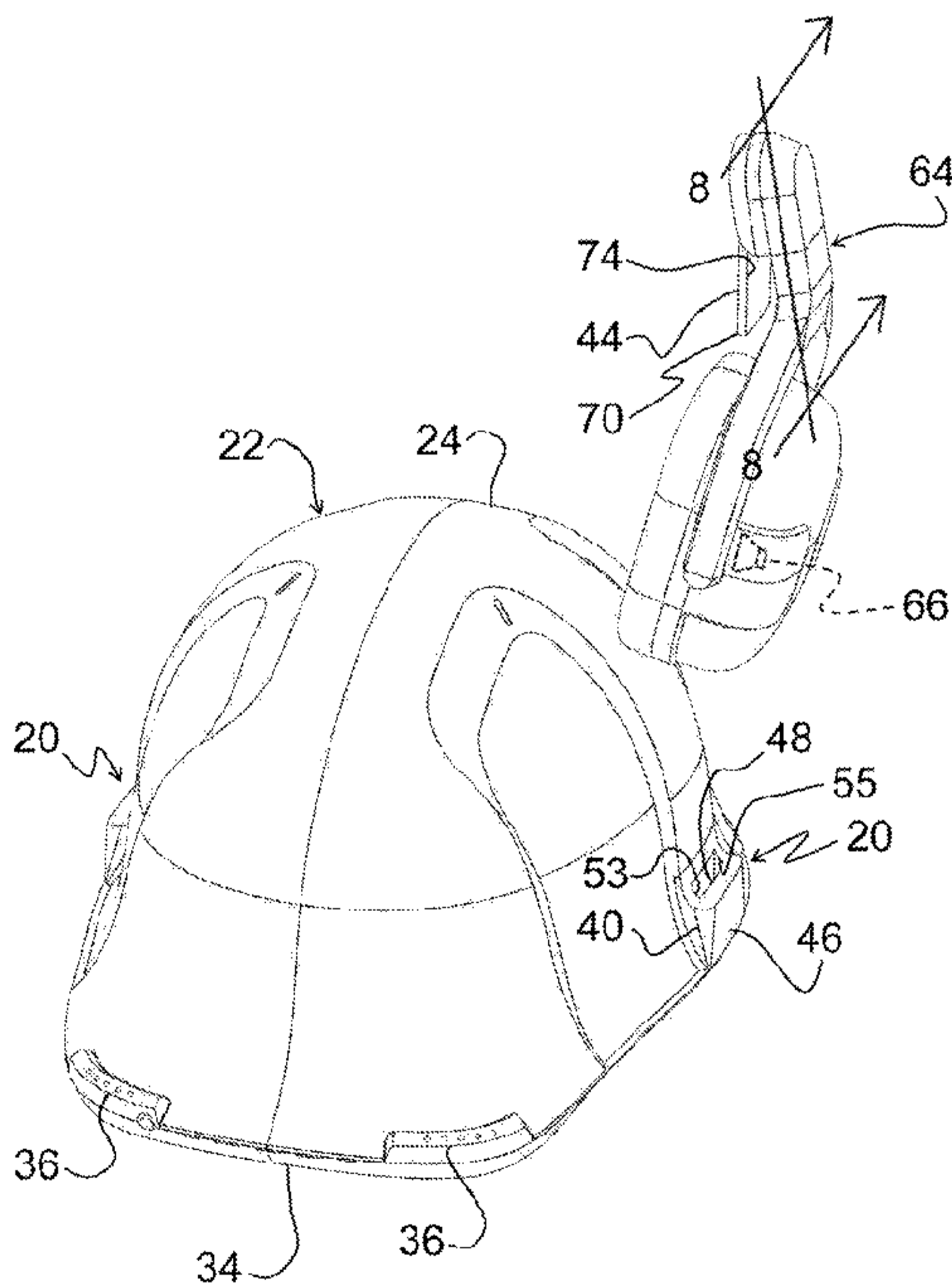
(12) INTERNATIONAL APPLICATION PUBLISHED UNDER THE PATENT COOPERATION TREATY (PCT)

(19) World Intellectual Property  
Organization  
International Bureau(43) International Publication Date  
27 April 2017 (27.04.2017)(10) International Publication Number  
**WO 2017/069961 A1**

- (51) International Patent Classification:  
*A42B 1/24* (2006.01)
- (21) International Application Number:  
PCT/US2016/056264
- (22) International Filing Date:  
10 October 2016 (10.10.2016)
- (25) Filing Language: English
- (26) Publication Language: English
- (30) Priority Data:  
14/883,157 14 October 2015 (14.10.2015) US  
15/087,972 31 March 2016 (31.03.2016) US
- (71) Applicant: **GUARDHAT, INC.** [US/US]; 20300 Civic Center Drive, #1103, Southfield, MI 48076 (US).
- (72) Inventors: **DEY, Saikat**; 1738 Fairview Street, Birmingham, MI 48009 (US). **REEPMEYER, Gerrit**; 20926 Chase Dr., Novi, MI 48375 (US). **SENGUPTA, Anupam**; 5906 Niles Drive, Troy, MI 48098 (US). **ZHAV-ORONKOV, Mikhail**; 48775 Running Trout Lane, Northville, MI 48168 (US). **PERUMAL, Senni**; 20300 Civic Center Drive #2103, Southfield, MI 48076 (US).
- FRIEDMAN, Steven**; 4315 Blenheim Way, Concord, CA 94521 (US).
- (74) Agent: **SIMONELLI, David, J.**; Simonelli IP, PLLC, P.O. Box 935, Birmingham, MI 48012 (US).
- (81) Designated States (*unless otherwise indicated, for every kind of national protection available*): AE, AG, AL, AM, AO, AT, AU, AZ, BA, BB, BG, BH, BN, BR, BW, BY, BZ, CA, CH, CL, CN, CO, CR, CU, CZ, DE, DJ, DK, DM, DO, DZ, EC, EE, EG, ES, FI, GB, GD, GE, GH, GM, GT, HN, HR, HU, ID, IL, IN, IR, IS, JP, KE, KG, KN, KP, KR, KW, KZ, LA, LC, LK, LR, LS, LU, LY, MA, MD, ME, MG, MK, MN, MW, MX, MY, MZ, NA, NG, NI, NO, NZ, OM, PA, PE, PG, PH, PL, PT, QA, RO, RS, RU, RW, SA, SC, SD, SE, SG, SK, SL, SM, ST, SV, SY, TH, TJ, TM, TN, TR, TT, TZ, UA, UG, US, UZ, VC, VN, ZA, ZM, ZW.
- (84) Designated States (*unless otherwise indicated, for every kind of regional protection available*): ARIPO (BW, GH, GM, KE, LR, LS, MW, MZ, NA, RW, SD, SL, ST, SZ, TZ, UG, ZM, ZW), Eurasian (AM, AZ, BY, KG, KZ, RU, TJ, TM), European (AL, AT, BE, BG, CH, CY, CZ, DE, DK, EE, ES, FI, FR, GB, GR, HR, HU, IE, IS, IT, LT, LU, LV, MC, MK, MT, NL, NO, PL, PT, RO, RS, SE, SI, SK,

[Continued on next page]

(54) Title: CONNECTION ASSEMBLY FOR ADJOINING A PERIPHERAL WITH A HOST WEARABLE DEVICE

**Figure 5**

(57) Abstract: A connection assembly for adjoining a peripheral with a host wearable device. Embodiment of the assembly can be a hardhat with an accessory connection slot allowing for both mechanical and electrical attachment of various accessories such as earphones, video display, headlamp, welder's face shield.

# WO 2017/069961 A1



SM, TR), OAPI (BF, BJ, CF, CG, CI, CM, GA, GN, GQ, GW, KM, ML, MR, NE, SN, TD, TG).

— *as to the applicant's entitlement to claim the priority of the earlier application (Rule 4.17(iii))*

**Declarations under Rule 4.17:**

— *as to applicant's entitlement to apply for and be granted a patent (Rule 4.17(ii))*

**Published:**

— *with international search report (Art. 21(3))*

**CONNECTION ASSEMBLY FOR ADJOINING A PERIPHERAL WITH A HOST  
WEARABLE DEVICE**

[0001] This is a continuation-in-part of United States patent application having serial number 14/883,157, filed October 14, 2015, which is a divisional of United States Patent 9,177,458, which is a divisional of United States Patent 9,013,297, which was filed on October 17, 2014.

**BACKGROUND ART**

[0002] 1. Field of the Invention

[0003] The invention relates generally to the field of 'smart' safety gear. More particularly, the invention relates to an accessory system for 'smart' safety devices providing mechanical connection mechanism as well as enabling data and power interchange between a peripheral and a host wearable device.

[0004] 2. Description of the Related Art

[0005] In today's manufacturing environments, workers often use various accessories such as earphones, face shield, headlamp, which attached to their head worn gear or other pieces of clothing or personal protective equipment. Current accessory attachment systems provide only means of mechanically connecting peripheral and host devices. As personal protective equipment becomes 'smart,' there exist a need for a simple and universal solution that allows both mechanical and electrical connectivity of the devices.

**Summary of the Invention**

[0006] A connection assembly adjoins a peripheral with a host wearable device. The connection assembly includes a housing secured to the host wearable

device. The housing defining a receptacle. An electrical contact extends through the housing into a portion of the host wearable device.

#### Brief Description of the Drawings

[0007] Advantages of the invention will be readily appreciated as the same becomes better understood by reference to the following detailed description when considered in connection with the accompanying drawings, wherein:

[0008] Figure 1 is a side view of one embodiment of the invention secured to a wearable device;

[0009] Figure 2 is a top view the wearable device of Figure 1;

[0010] Figure 3 is a bottom perspective view of the wearable device;

[0011] Figure 4 is a cross-sectional view taken along lines 4-4 of Figure 1;

[0012] Figure 5 is an exploded perspective view of a wearable device with an earphone accessory;

[0013] Figure 6 is a perspective view of a wearable device with an earphone accessory secured thereto;

[0014] Figure 7 is a partially cut away cross-sectional side view taken along lines 7-7 of Figure 1;

[0015] Figure 8 is a partially cut away cross-sectional side view taken along lines 8-8 of Figure 5;

[0016] Figure 9 is a partially cut away cross-sectional side view taken along lines 9-9 of Figure 6;

[0017] Figure 10 is a perspective view of a wearable device with two peripherals secured thereto in a stacked relation; and

[0018] Figure 11 is an exploded perspective view the wearable device with the second peripheral removed from the first peripheral.

#### Detailed Description of the Preferred Embodiment

[0019] Workers use a connection assembly to attach various peripheral devices (e.g. headphones, welder's shield, video display, etc.) both mechanically and electrically to a host wearable device. The connection assembly is design in the way that it accommodates existing non-electrical accessories. In addition to mechanical attachment mechanism the assembly includes circuitry providing a data interface and a power interface. Such assembly will allow exchange of data (including audio and video signals) between a host wearable device and an attached 'smart' peripheral device as well as provide power to the device. Accessory connectors can be designed in the way to allow for multiple accessories connected to a single host port simultaneously (hereinafter referred to as "stacking"). Data and power interface may be compatible with industry standards for electrical connectors and communication protocols such as USB, UART, PBI, FireWire and the like. Because the host wearable device may be worn in a volatile environment, the peripherals must be secured and electrically connected to the host wearable device using a spark inhibited connection.

[0020] Referring to Figures 1 through 3, one embodiment of the invention is generally indicated at 20. The invention is a connection assembly 20 The connection assembly 20 is secured to a host wearable device, generally shown at 22. In this embodiment, the host wearable device 22 is a piece of protective head

gear commonly referred to as a hard hat. It should be appreciated by those skilled in the art that the host wearable device 22 may be a vest, jacket, collar, gloves or any other device adapted to be worn by an operator.

[0021] The hard hat 22 has an outer shell 24 that is hard. The outer shell 24 is designed to cover an adult head. The outer shell 24 includes a periphery 26 that defines an opening 28 (best seen in Figure 3). The hard hat 22 typically includes a harness 30 so that the hard hat 22 does not have to sit directly on the head of the operator. In the embodiment shown, the harness 30 has an adjuster 32 that will allow the operator to adjust the harness 32 to the proper size so that the hard hat 22 will fit on the head comfortably, yet tight enough that the hard hat 22 will not simply fall off.

[0022] The hard hat 22 also includes a visor 34 to help protect the face of the operator wearing the hard hat 22. Electronics 36 may be secured to the visor 34 or any other part of the hard hat 22. The electronics 36 connected to the hard hat are the subject of United States Patents 9,013,297 and 9,177,458, the content of which is incorporated herein by reference.

[0023] In the embodiment shown in the Figures, there are two connection assemblies 20 that are secured to the host wearable device (hard hat) 22. These two connection assemblies 20 are diametrically opposite each other. In other embodiments, there may be more or less connection assemblies 20 secured to the hard hat 22, the use of more or less would depend on the environment in which the hard hat 22 is being deployed.

[0024] While it is shown that two connection assemblies 20 are secured to the hard hat 22, the remainder of the discussion will only discuss a single

connection assembly 20 as the two operate identically. Each connection assembly 20 will operate the same way even though some embodiments may have different connection assemblies 20 with different configurations.

[0025] The connection assembly 20 includes a housing 40 secured to the hard hat 22. More specifically, the housing 40 is secured to the outer shell 24 of the hard hat 22. The housing 40 is fabricated from a material that is hard, like the outer shell 24. In many instances, the housing 40 will be formed integrally with the outer shell 24.

[0026] The housing 40 defines a receptacle 42. The receptacle 42 is designed to receive a peripheral adapter 44, discussed in greater detail subsequently. The receptacle 42 is a generally rectangular tube having a sidewall 46 extending vertically up a portion of the outer shell 24. The receptacle 42 has upper 48 and lower 50 apertures. The peripheral adapter 44 may be designed to be inserted into either of these openings 48, 50. In an embodiment not shown, the receptacle 42 would have a portion of its side wall 46 removed for either securing alternatively designed peripherals, or for cleaning the interior of the receptacle 42. The side wall 46 includes an inner side wall surface 52, which will be discussed in greater detail subsequently. Two guides 53, 55 are used to guide the peripheral adapter 44 into the receptacle 42. The guides 53, 55 may be simple side walls, as shown in the Figures, or they may include grooves.

[0027] The connection assembly 20 also includes an electrical contact 54. The electrical contact 54 extends along at least one interior wall 56 of the receptacle 42. The electrical contact 54 may include a plurality or set of contacts 54, 54', 54" (shown in Figure 1), so that multiple functions may be performed through the single "point" of contact. By way of example, if the electrical contact

54 is a single contact, it may merely provide a voltage at that point. If the electrical contact is actually a set of contacts 54, 54', 54", each may supply a voltage, a data signal, and audio/video signal, respectively. Depending on the protocol and data compression used, one or more types of data may be transmitted through a single contact. Additional electrical contacts may be incorporated into the guides 53, 55, depending on the data capacity requirements.

[0028] The electrical contact 54 is electrically connected to a conductor 58, which in turn is electrically connected to a control unit 60. The control unit 60 may extend along a front of the hard hat 22, as shown in Figure 6, or it may be housed within an electronics housing 62, as shown in Figure 4, and supplies power (from a battery, not shown, housed within a battery housing 63) and data to and from the electrical contact 54, as well as any electronics 36 embedded in the host wearable device 22. The control unit 60 is described in greater detail in the above-mentioned United States Patents.

[0029] Referring to Figures 5, 6, 8 and 9, a peripheral is generally shown at 64. In these Figures, the peripheral 64 is a pair of earmuffs (only two shown in Figures 10 and 11). The earmuffs 64 muffle or absorb noise created in the environment to protect the ears of the operator. The earmuffs 64 also have the ability to transmit information to the operator via audio signals through a speaker 66 (shown in phantom) and they have the ability to sense information if the earmuffs 64 were so equipped. For example, the earmuffs 64 may have an ambient light sensor or an ambient temperature sensor affixed thereto. A body temperature may also be secured to the earmuffs to measure the temperature of the operator.

[0030] Communication of these signals to and from the electrical devices (graphically represented by the microphone 66) installed in the earmuffs 64 is

achieved through the peripheral adapter 44. The peripheral adapter 44 includes an adapter contact 68, which is wired through an appropriate wire harness to the electrical devices 66 hosted by the earmuffs 64. In Figure 11, three adapter contacts 68, 68', 68" are shown to electrically connect to the three electrical contacts 54, 54', 54" of Figure 1. The peripheral adapter 44 is designed to be inserted into the connection assembly 20. The peripheral adapter 44 extends down to a distal end 70. The peripheral adapter 44 may be shorter than the length of the receptacle 42 and, as such, may not extend therepast when fully inserted into the receptacle 42. The peripheral adapter 44 has an outboard surface 72 to which the adapter contact 68 is secured. As discussed above, there may be a set of adapter contacts 68, 68', 68" secured to the outboard surface 72 that will be in electrical contact with the set of electrical contacts 54, 54', 54" through a press fit physical contact.

[0031] The peripheral adapter 44 also includes a bias surface 74. The bias surface 74 abuts the inner sidewall surface 52 of the receptacle 42. The bias surface 74 forces adapter contact(s) 68 into engagement with the electrical contact(s) 54. Through friction, the bias surface 74 locks the peripheral adapter 44 into the connection assembly 20. This prevents the peripheral 64 from being disconnected from the hard hat 22. In an alternative embodiment, a physically distinct locking surface or relief is used to positively prevent the peripheral adapter 44 from exiting the receptacle 42.

[0032] Referring now to Figure 10, the host wearable device 22 is shown with a second peripheral 80. The second peripheral 80 is a convertible face protective shield with an augmented reality display. The operator using the host wearable device 22 may move the convertible face protective shield 80 into and

out of a use position depending on the job used. In Figure 10, the convertible face protective shield 80 is not in its use position; but in a retracted position.

[0033] Referring to Figure 11, the second peripheral 80 includes a peripheral control unit 90 that may include a power transformer, if necessary. The peripheral control unit 90 communicates with the control unit 60 through a set of adapter contacts 92 that allow power to be received thereby and to allow data to be transmitted or received therefrom. In one embodiment, the convertible face protective shield 80 would include a screen device 94 that could transmit video in a holographic or projection manner. In another instance, the screen device 94 could include a coating for the outer surface 82. The coating could be a transparent "touch screen" film allowing the operator greater communication and data bidirectional transmission freedom. The second peripheral 80 will be stacked within the first set of peripherals 64 using slots 96 designed to receive and electrically connect the second peripheral 80 therewithin. If the second peripheral 80 is not being used, caps (not shown) may be secured over the slots 96 to protect the components within the slots 96 from being damaged.

[0034] The second peripheral 80 is stacked with respect to the first peripheral 64 in that the adapter contacts of the second peripheral 80 extend along a peripheral adapter that is received by first peripheral 64, which provides an electrical connection from the second peripheral 80 to the host wearable device 22 through the connection assembly 20.

[0035] Not to be construed in a limiting manner, a list of potential peripheral devices may include: headphones, augmented reality displays, face shields, welder's visors, flashlights, visibility lights, various biometric and environmental

sensors, wireless communication devices (including cell phones), microphones, CB radios, cameras, gas masks, chin straps, ear muffs, safety glasses, liners and the like.

[0036] The invention has been described in an illustrative manner. It is to be understood that the terminology, which has been used, is intended to be in the nature of words of description rather than of limitation.

[0037] Many modifications and variations of the invention are possible in light of the above teachings. Therefore, within the scope of the appended claims, the invention may be practiced other than as specifically described.

**We claim:**

1. A connection assembly for adjoining a peripheral with a host wearable device, said connection assembly comprising:

a housing secured to the host wearable device, said housing defining a receptacle; and

an electrical contact extending through said housing into a portion of the host wearable device.

2. A connection assembly as set forth in claim 1 including a bias surface disposed along a portion of said housing to secure the peripheral to said housing.

3. A connection assembly as set forth in claim 1 wherein said receptacle defines an aperture through which a portion of the peripheral extends.

4. A connection assembly as set forth in claim 1 including a second contact extends through a portion of the host wearable device and said receptacle to provide power to the peripheral.

5. A connection assembly as set forth in claim 1 wherein said receptacle includes an open end allowing access to said electrical contact.

6. A connection assembly as set forth in claim 1 wherein said receptacle includes a bias surface forcing a portion of the peripheral into contact with said electrical contact maintaining a closed circuit between said electrical contact and the peripheral as long as the peripheral within said receptacle.

7. A connection assembly as set forth in claim 5 wherein said bias surface extends at an angle with respect to said electrical contact.

8. A connection assembly as set forth in claim 4 wherein said electrical contact is a data interface.

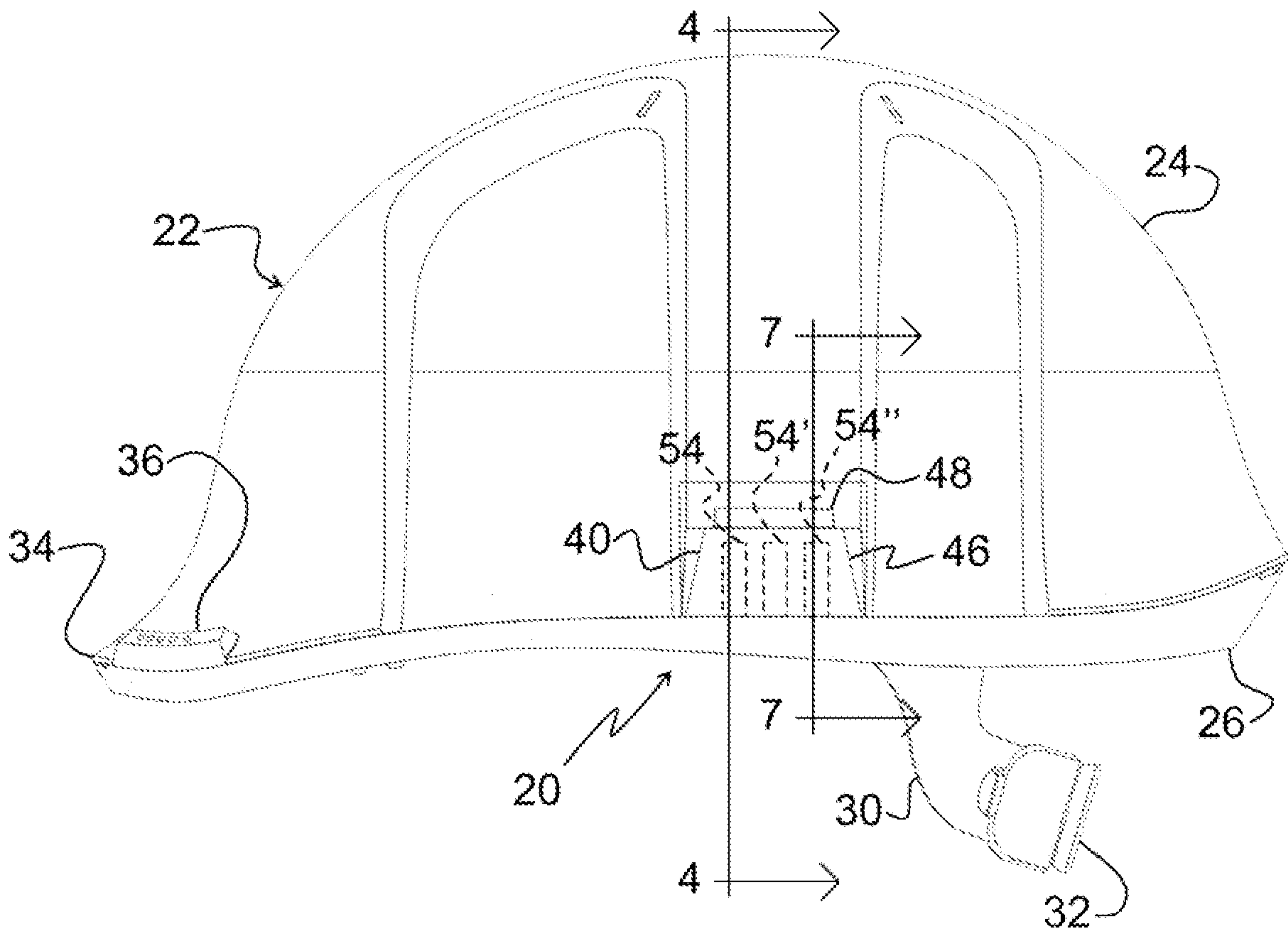
9. A connection assembly as set forth in claim 8 wherein said second contact is a power interface.

10. A hard hat assembly comprising:  
a base ring encircling a head of a user;  
a covering extending up from the base ring to cover and protect the head;  
a connector for adjoining a peripheral to said hard hat assembly, said connector including a housing secured to said base ring, said housing defining a receptacle and a bias surface for locking the peripheral to said receptacle; and  
an electrical contact extending through a portion of said hard hat assembly.

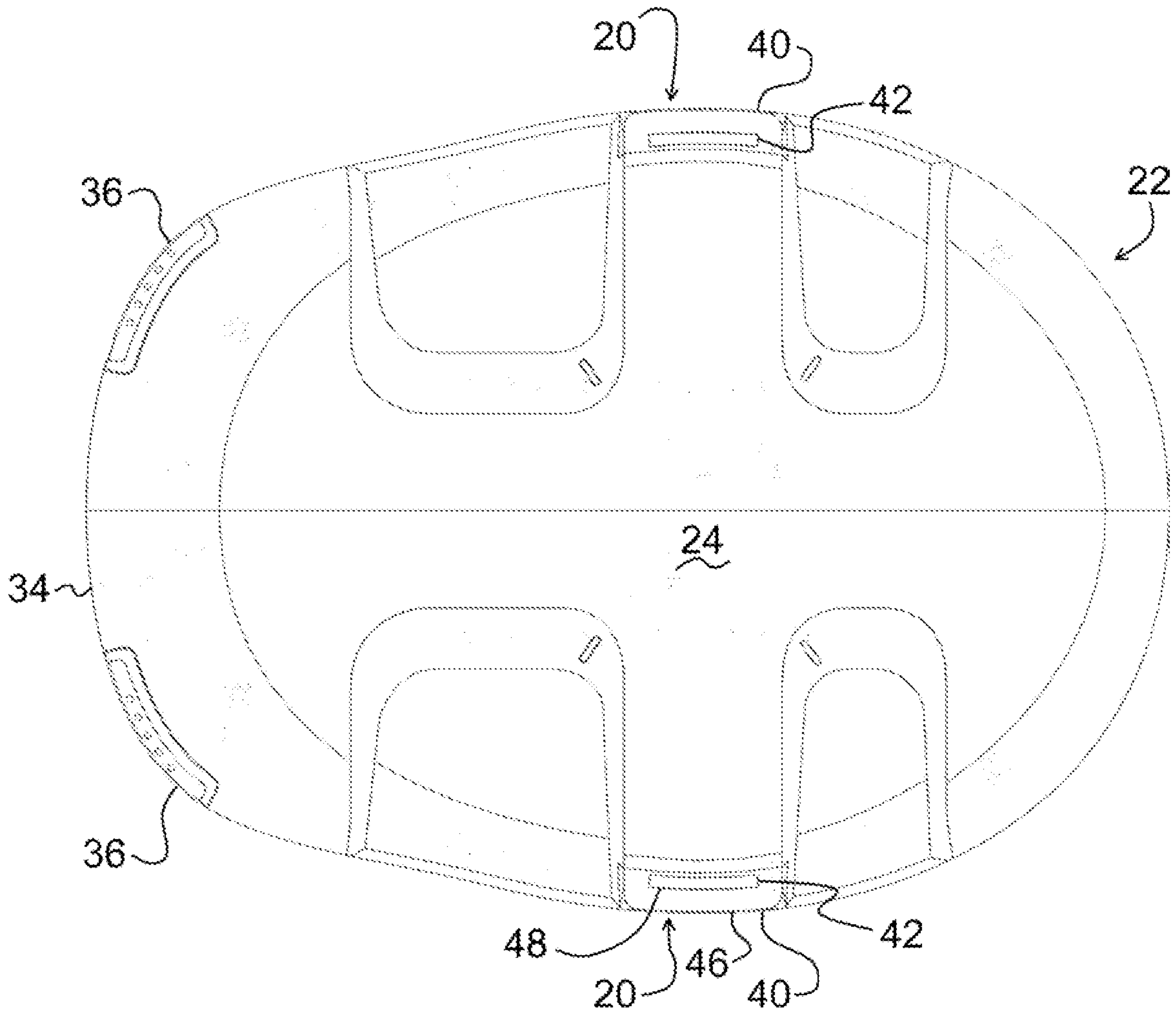
11. A hard hat assembly as set forth in claim 10 wherein said connector includes a plurality of electrical contacts allowing for multiple peripherals to be secured thereto.

12. A hard hat assembly as set forth in claim 11 including a control unit for controlling the plurality of peripherals secured to said hard hat assembly.

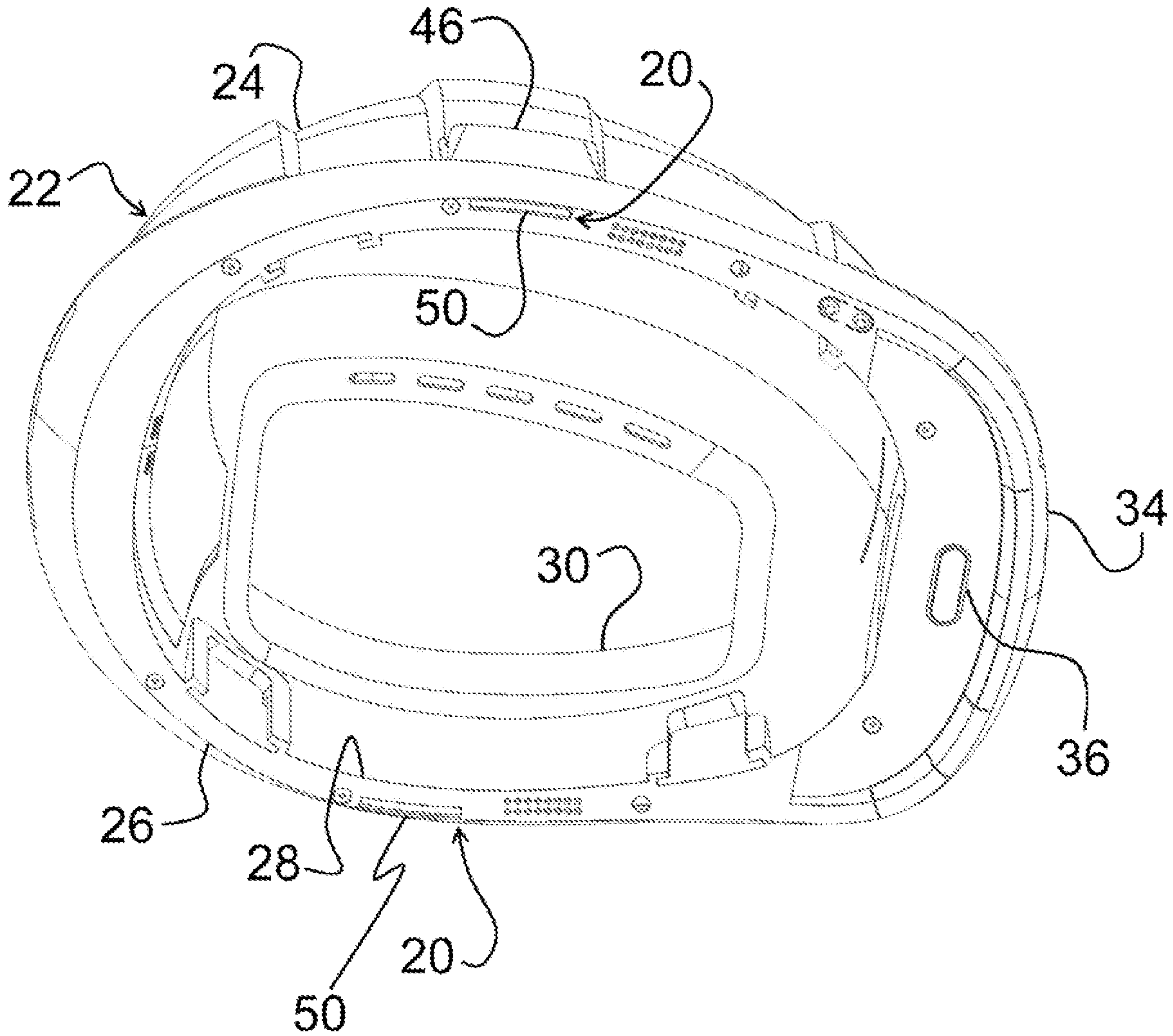
**Figure 1**



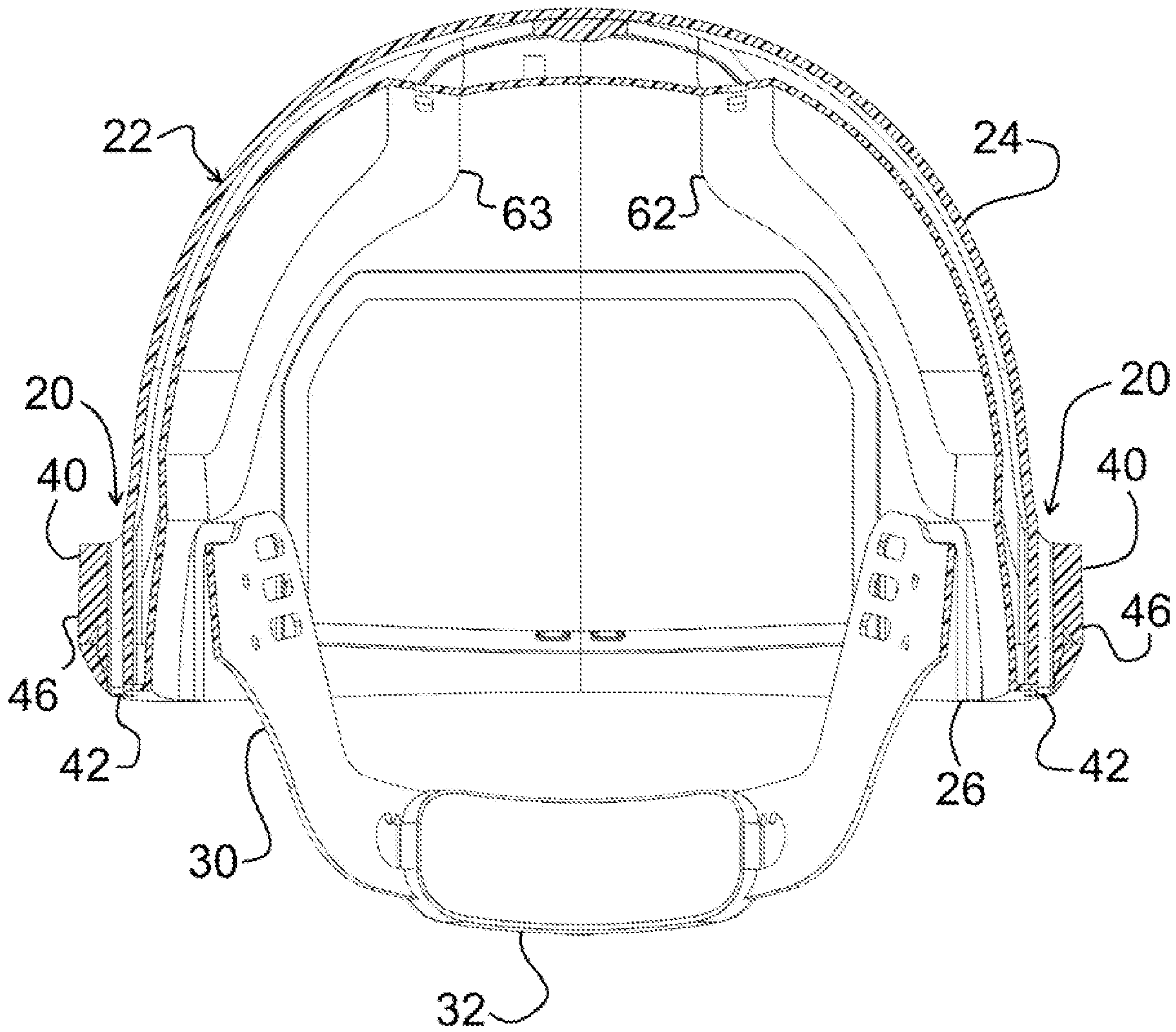
**Figure 2**



**Figure 3**

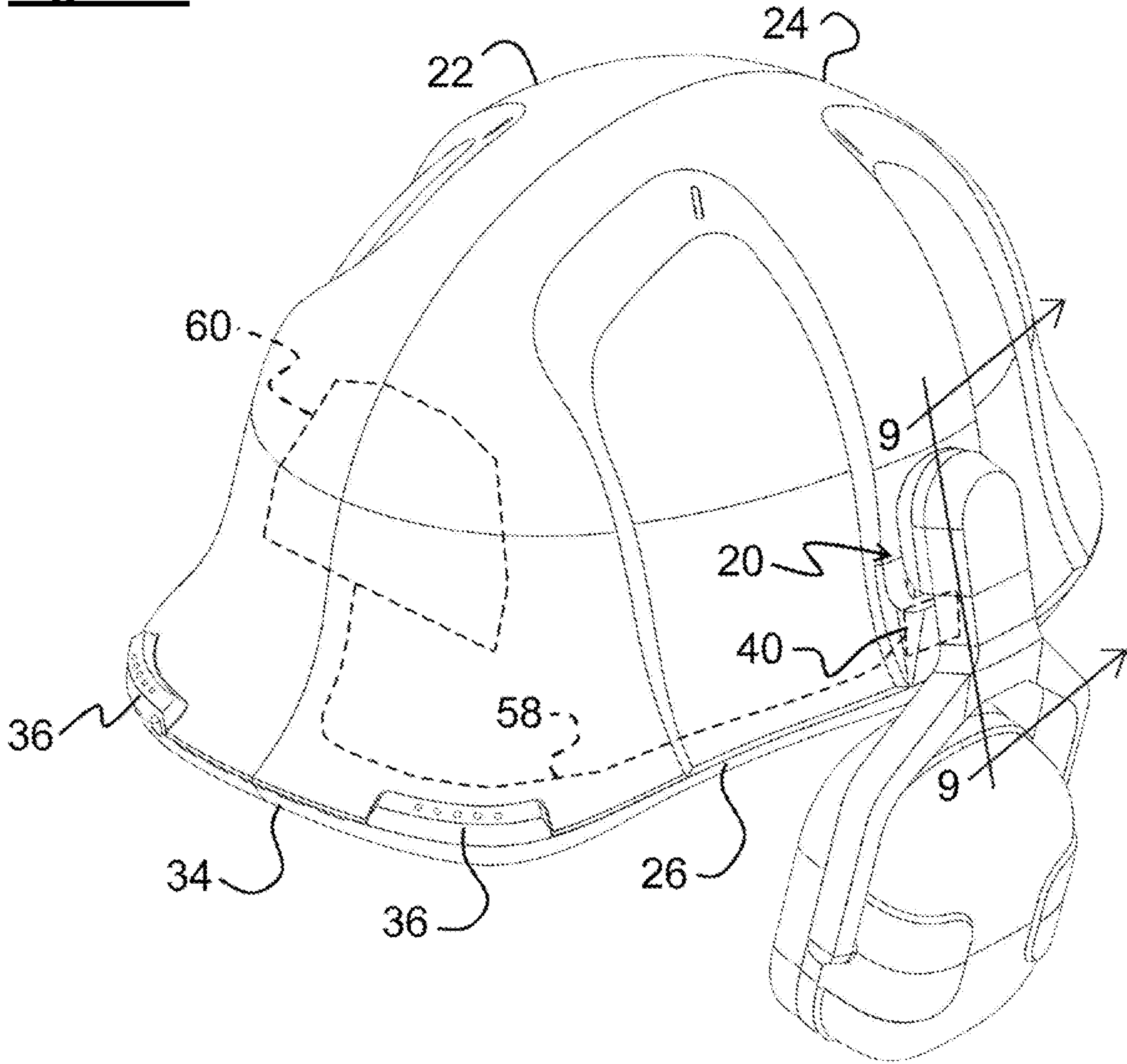


**Figure 4**

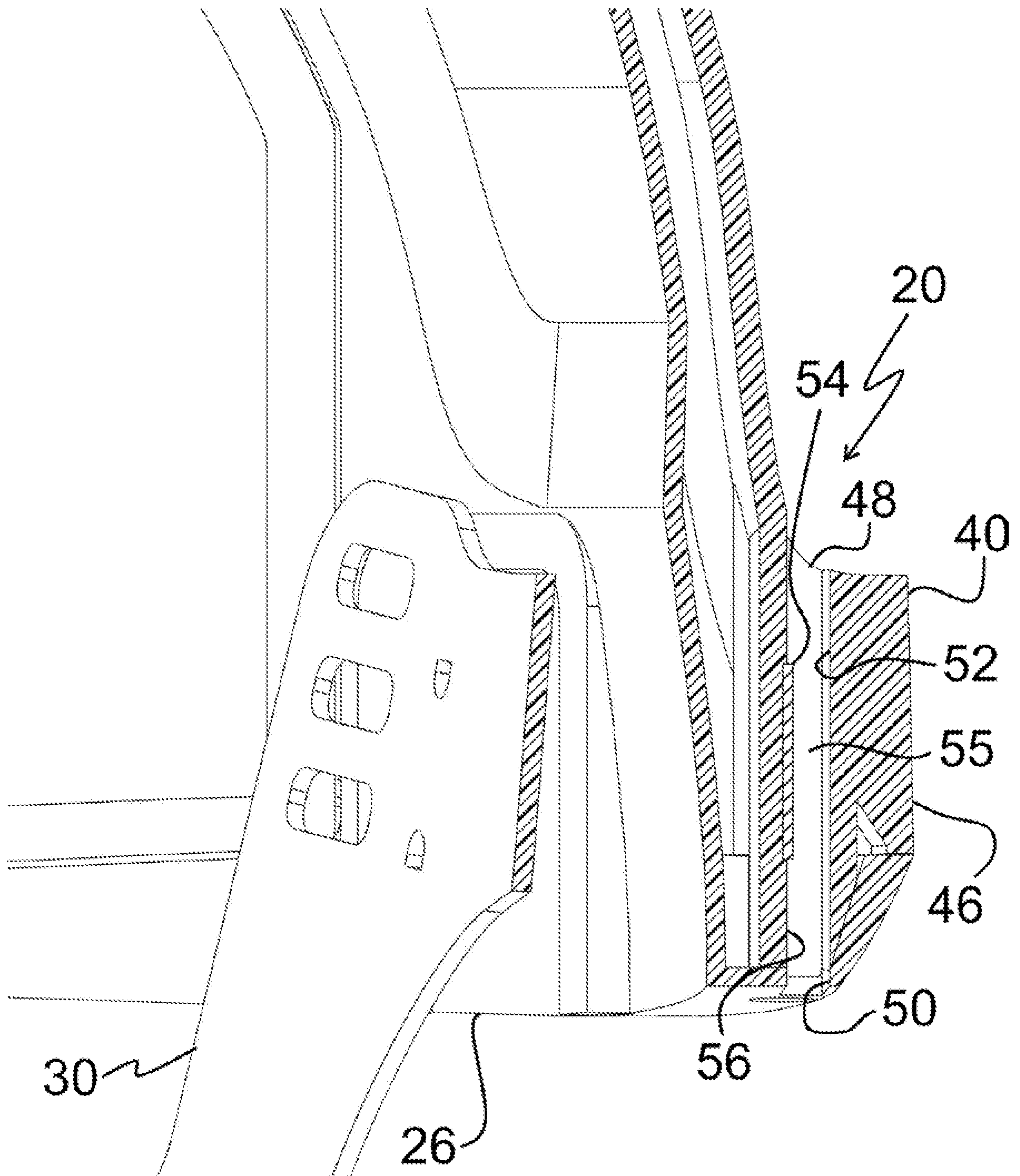




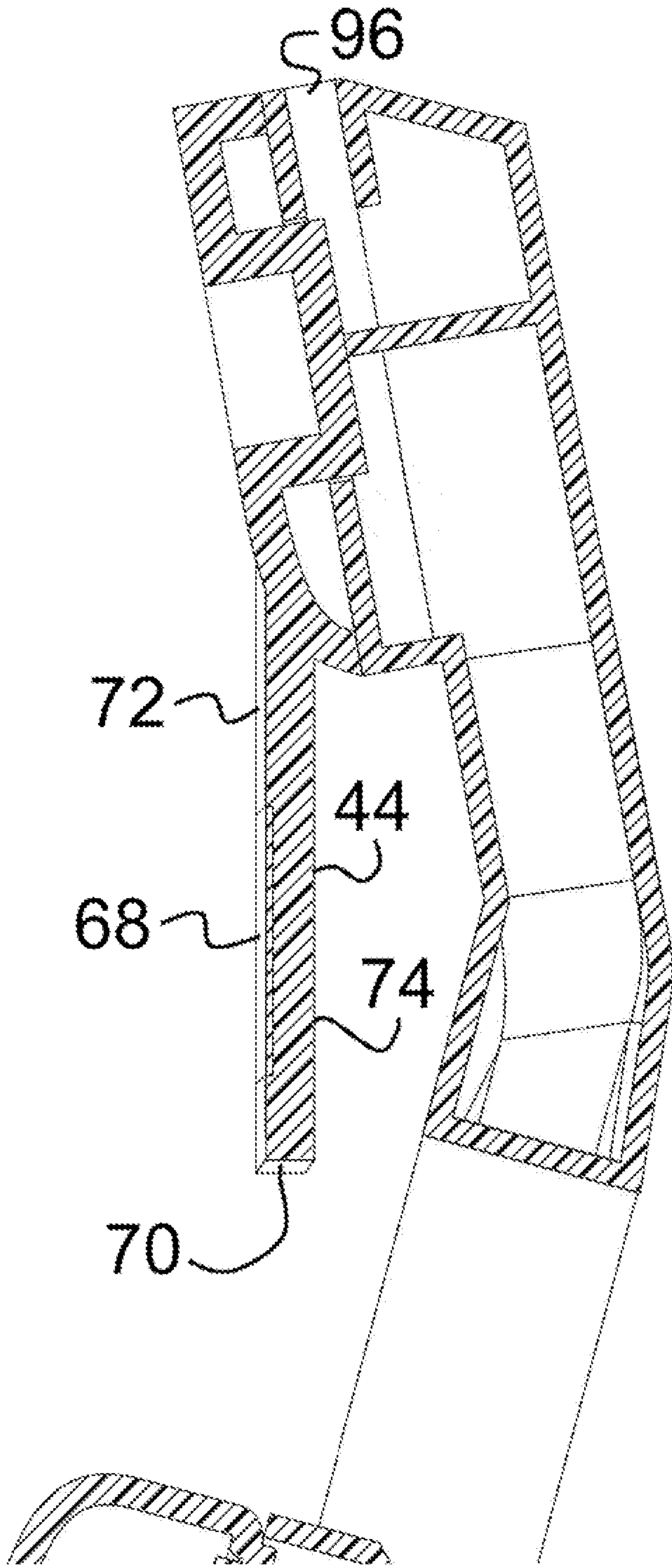
**Figure 6**



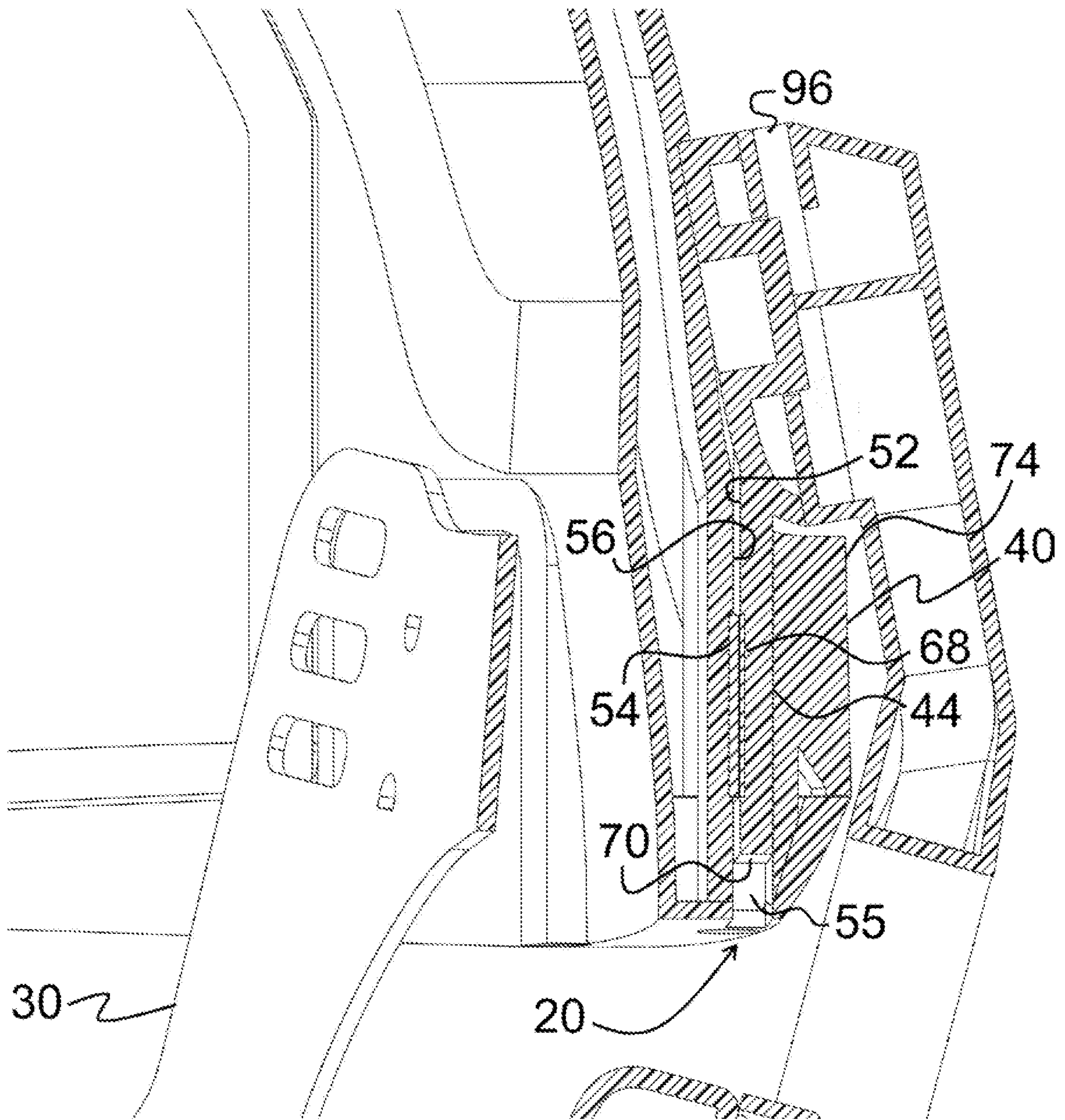
**Figure 7**



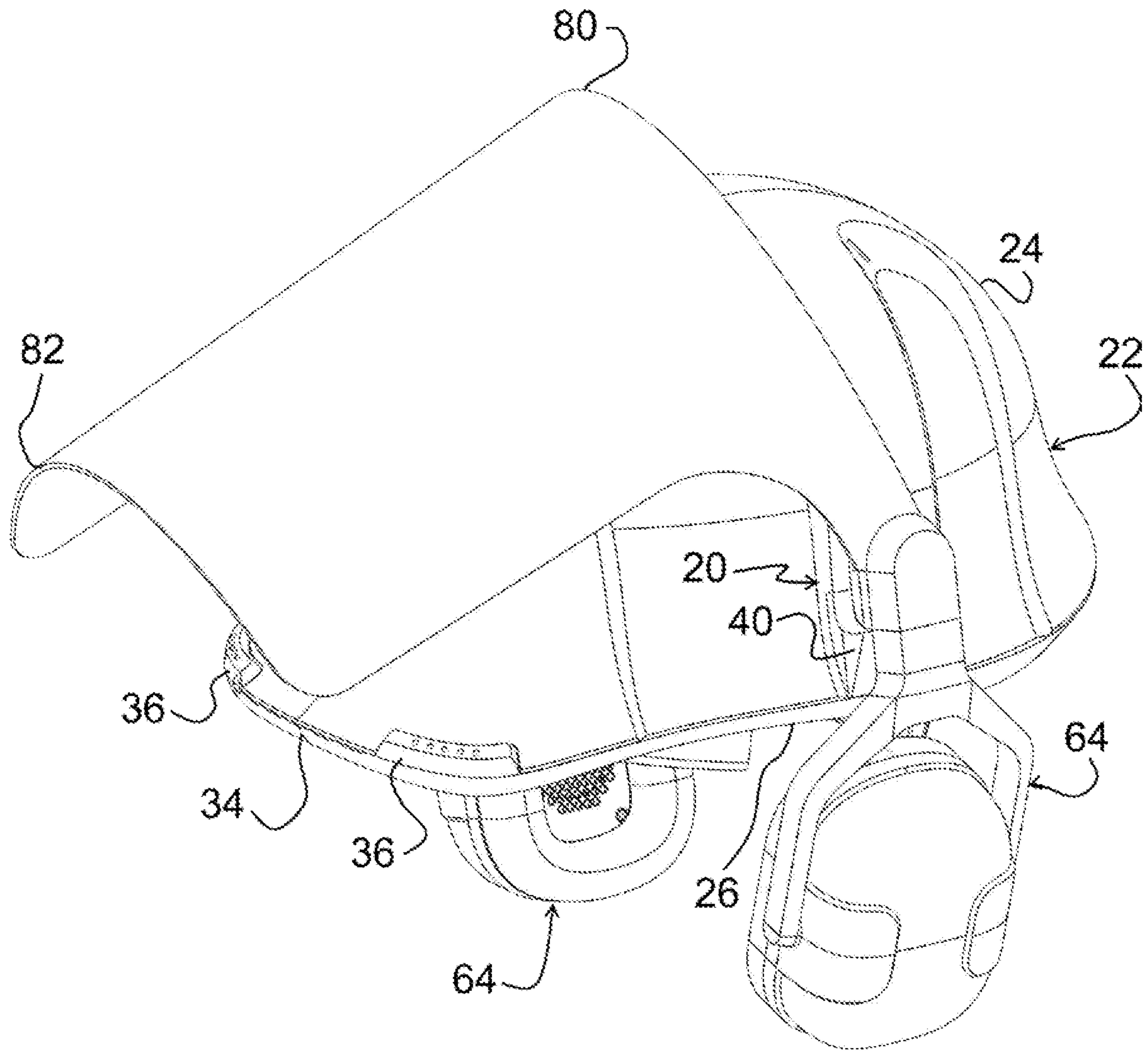
**Figure 8**



**Figure 9**



**Figure 10**



**Figure 11**

