

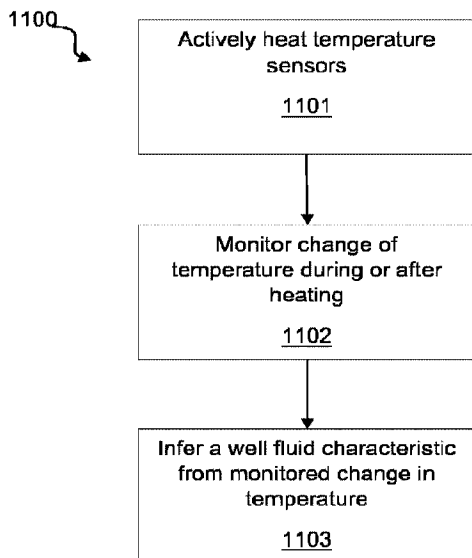

(86) Date de dépôt PCT/PCT Filing Date: 2017/05/26
 (87) Date publication PCT/PCT Publication Date: 2017/11/30
 (45) Date de délivrance/Issue Date: 2022/09/20
 (85) Entrée phase nationale/National Entry: 2018/11/20
 (86) N° demande PCT/PCT Application No.: GB 2017/051526
 (87) N° publication PCT/PCT Publication No.: 2017/203296
 (30) Priorité/Priority: 2016/05/26 (GB1609295.9)

(51) Cl.Int./Int.Cl. *E21B 47/06* (2012.01)
 (72) Inventeurs/Inventors:
 JARVIS, LESLIE DAVID, GB;
 ROSS, SHAUN COMPTON, GB
 (73) Propriétaire/Owner:
 METROL TECHNOLOGY LIMITED, GB
 (74) Agent: FOGLER, RUBINOFF LLP

(54) Titre : APPAREILS ET PROCÉDES POUR DETECTER LA TEMPERATURE LE LONG D'UN Puits DE FORAGE EN UTILISANT DES ELEMENTS RESISTIFS
 (54) Title: APPARATUSES AND METHODS FOR SENSING TEMPERATURE ALONG A WELLBORE USING RESISTIVE ELEMENTS



(57) **Abrégé/Abstract:**

Apparatus for use in sensing temperature in a wellbore, comprising: tubing comprising a plurality of temperature sensor modules provided at locations along the inside of the tubing, said temperature sensor modules comprising temperature sensors provided at least in part by at least one resistive element having electrical properties that vary with temperature; an electrical network configured to electrically connect to the resistive elements to in use allow measuring of the respective electrical properties of the resistive elements to infer a thermal characteristic of the resistive element; and at least one control module electrically connected to multiple temperature sensor modules, via the electrical network, and configured to receive and process an electrical signal associated with the temperature sensor modules to enable inference of the temperature of the resistive elements and the environment to which the tubing is exposed at the location of that resistive element.

(12) INTERNATIONAL APPLICATION PUBLISHED UNDER THE PATENT COOPERATION TREATY (PCT)

(19) World Intellectual Property
Organization
International Bureau



(10) International Publication Number
WO 2017/203296 A1

(43) International Publication Date
30 November 2017 (30.11.2017)

- (51) International Patent Classification:
E21B 47/06 (2012.01)
- (21) International Application Number:
PCT/GB2017/051526
- (22) International Filing Date:
26 May 2017 (26.05.2017)
- (25) Filing Language: English
- (26) Publication Language: English
- (30) Priority Data:
1609295.9 26 May 2016 (26.05.2016) GB
- (71) Applicant: **METROL TECHNOLOGY LIMITED** [GB/GB]; Unit 24, Kirkhill Place, Kirkhill Industrial Estate, Dyce, Aberdeen Aberdeenshire AB21 0GU (GB).
- (72) Inventors: **JARVIS, Leslie David**; Liathach, Woodcot Lane, Stonehaven Aberdeenshire AB39 2GJ (GB). **ROSS, Shaun Compton**; West Cults House, 493 North Deeside Road, Aberdeen Aberdeenshire AB15 9ES (GB).
- (74) Agent: **HGF LIMITED (ABERDEEN)**; 1 City Walk, Leeds, West Yorkshire LS11 9DX (GB).
- (81) Designated States (*unless otherwise indicated, for every kind of national protection available*): AE, AG, AL, AM, AO, AT, AU, AZ, BA, BB, BG, BH, BN, BR, BW, BY, BZ, CA, CH, CL, CN, CO, CR, CU, CZ, DE, DJ, DK, DM, DO, DZ, EC, EE, EG, ES, FI, GB, GD, GE, GH, GM, GT, HN, HR, HU, ID, IL, IN, IR, IS, JP, KE, KG, KH, KN, KP, KR, KW, KZ, LA, LC, LK, LR, LS, LU, LY, MA, MD, ME, MG, MK, MN, MW, MX, MY, MZ, NA, NG, NI, NO, NZ, OM, PA, PE, PG, PH, PL, PT, QA, RO, RS, RU, RW, SA, SC, SD, SE, SG, SK, SL, SM, ST, SV, SY, TH, TJ, TM, TN, TR, TT, TZ, UA, UG, US, UZ, VC, VN, ZA, ZM, ZW.
- (84) Designated States (*unless otherwise indicated, for every kind of regional protection available*): ARIPO (BW, GH, GM, KE, LR, LS, MW, MZ, NA, RW, SD, SL, ST, SZ, TZ, UG, ZM, ZW), Eurasian (AM, AZ, BY, KG, KZ, RU, TJ, TM), European (AL, AT, BE, BG, CH, CY, CZ, DE, DK, EE, ES, FI, FR, GB, GR, HR, HU, IE, IS, IT, LT, LU, LV, MC, MK, MT, NL, NO, PL, PT, RO, RS, SE, SI, SK, SM,

(54) Title: APPARATUSES AND METHODS FOR SENSING TEMPERATURE ALONG A WELLBORE USING RESISTIVE ELEMENTS

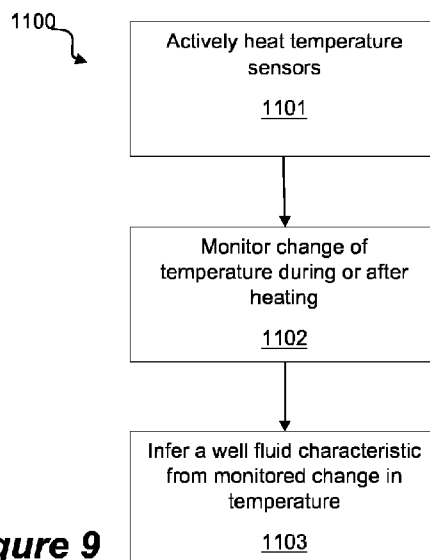

Figure 9

(57) Abstract: Apparatus for use in sensing temperature in a wellbore, comprising: tubing comprising a plurality of temperature sensor modules provided at locations along the inside of the tubing, said temperature sensor modules comprising temperature sensors provided at least in part by at least one resistive element having electrical properties that vary with temperature; an electrical network configured to electrically connect to the resistive elements to in use allow measuring of the respective electrical properties of the resistive elements to infer a thermal characteristic of the resistive element; and at least one control module electrically connected to multiple temperature sensor modules, via the electrical network, and configured to receive and process an electrical signal associated with the temperature sensor modules to enable inference of the temperature of the resistive elements and the environment to which the tubing is exposed at the location of that resistive element.

[Continued on next page]



WO 2017/203296 A1

WO 2017/203296 A1 

TR), OAPI (BF, BJ, CF, CG, CI, CM, GA, GN, GQ, GW,
KM, ML, MR, NE, SN, TD, TG).

Published:

— *with international search report (Art. 21(3))*

APPARATUSES AND METHODS FOR SENSING TEMPERATURE ALONG A WELLBORE USING RESISTIVE ELEMENTS

FIELD OF THE TECHNOLOGY

- 5 The invention relates generally to sensing temperature along a wellbore. More particularly, the invention relates to methods and apparatuses for sensing temperature along a wellbore using resistive elements, and to a well incorporating said apparatuses, and to methods of calibrating said apparatuses.

BACKGROUND

- 10 Wells are drilled for a variety of purposes commonly relating to hydrocarbon exploration or extraction. Various well logging tools and methods may be used to gain data from wells during the drilling, testing, completion, production, suspension and abandonment stages of a well. This data can be used for a number of reasons, such as to optimise production from the reservoir or to design further wells in the same reservoir. The development of a model for
15 the well and the flow rate from the formations opening into the well can greatly facilitate the targeted exploitation of the reservoir.

- It is particularly important to exploration and extraction to collect data relating to the volumetric flow rate and pressure from various formations inside the well. Current tools and methods for logging volumetric flow rate and pressure can be costly and complicated,
20 whereas it would be preferable to collect accurate, high-resolution data with as few technical and procedural constraints and requirements as possible.

- Collecting temperature monitoring data along a wellbore can be useful in determining the type and flow rate of fluids entering a well. For example, oil entering a well at a given location generally has a warming effect, whereas water entering a well has an even greater
25 warming effect. On the other hand, gas typically has a cooling effect, as do the heavy fluids that are typically used to balance and kill wells at the end of their lives. Generally, these warming and cooling effects are exaggerated where the flow rate of those fluids is greater.

- Currently, the most commonly used tool for accurately sensing a temperature along a wellbore is a fibre-optic based distributed temperature sensor (DTS) system. These systems
30 typically rely on information contained in the backscattered light from locations along the length of a fibre running along a wellbore, such as the frequency, time of flight, and intensity thereof, to infer a local temperature variation of the fibre due to the local environment that has caused the backscattering. DTS systems can provide a continuous temperature profile along the length of the fibre down to a spatial resolution of around 1 metre with a high level
35 sensitivity and accuracy. However, the interrogator unit that generates and couples light into

the fibre optics and that senses and analyses the backscattered light to generate the temperature data typically has to be provided at the surface of the well, generally coupled through the Christmas tree. Thus, the length of the fibre-optic that has to be run into the well can be considerable. For example, where a well test is being run on a short, 100 m section
5 of well at a depth of 4000 m (as a measured depth from a rotary table of a drill rig, MDRT), a length of fibre-optic of greater than 4 km is necessary to test only 100 m of the well. Further, as packers or other annular seals against the wellbore surface are usually used to isolate sections of the well under test, for example during Drill Stem Testing (DST), the fibre-optic cabling is required to penetrate through or extend across the packer which can significantly
10 complicate the design of the DTS system, the packer, and significantly add to the cost of the test.

An alternative to the prior art DTS systems that has been introduced to the market by Schlumberger is the WellWatcher Flux™ digital temperature array
([http://www.slb.com/~media/Files/completions/product_sheets/wellwatcher/wellwatcher_flux
15 _ps.pdf](http://www.slb.com/~media/Files/completions/product_sheets/wellwatcher/wellwatcher_flux_ps.pdf)). In this system, instead of using fibre optics, arrays of miniaturised, hermetically sealed, resistive temperature sensors are provided at intervals along the length of a 1/4 inch (6.35mm) diameter tubing. The tubing is again connected through the Christmas tree at the well head and control electronics provided at each temperature sensor array provide a digital readout of the sensed temperature data at the arrays via an RS-485 connection. While the
20 arrays of temperature sensors are provided in a 1/4 inch (6.35mm) diameter tubing, the temperature sensors produce larger diameter sections of the tubing, having an outer diameter of at least 17mm for at least 400mm in length.

In such digital temperature arrays having this type of construction and operation, the larger sections containing the temperature sensors and control electronics are welded to the
25 tubing, which means that the process for manufacturing the digital temperature array of this can be complicated requiring a number of different components and steps to be constructed separately and joined together. The provision of a significant amount of complicated control electronics is required in each enlarged section of the tubing to try to achieve autonomous sensors that have a desired accuracy, which can lead to the sensor modules being bulky
30 and does not lend itself to miniaturisation or ruggedisation of the sensor modules for reliable operation in hazardous environments downhole, particularly in open hole configurations. The use of individual digital sensor modules is prone to drift, not only of the sensor, but also of the individual measurement and reference electronics, and can lead to undesirable drift of the temperature data from sensor modules relative to one another... Further, as the tubing
35 has extended sections with a larger outer diameter, these render the digital temperature array complicated and difficult to manufacture, install and use and relatively fragile in the well. Due to the extended sections, with larger outer diameters, the array is also difficult to

install in small spaces and difficult to seal against. For example, installing the digital temperature arrays of this type across packers can be particularly difficult.

It is in this context that the present invention has been devised.

SUMMARY OF THE INVENTION

5 Viewed from one aspect, the present invention provides apparatus for use in sensing temperature in a wellbore, comprising: tubing comprising at least 6 temperature sensor modules provided at locations along the inside of the tubing, said temperature sensor modules comprising temperature sensors provided at least in part by at least one resistive element having electrical properties, for example electrical resistance, that vary with
10 temperature; an electrical network configured to electrically connect to the resistive elements to in use allow measuring of the respective electrical properties of the resistive elements to infer a thermal characteristic (which may be a temperature characteristic) of the resistive element; and at least one control module electrically connected to multiple temperature sensor modules, via the electrical network, and configured to receive and process an
15 electrical signal associated with the temperature sensor modules to enable inference of the temperature of the resistive elements and the environment to which the tubing is exposed at the location of that resistive element, wherein the tubing outer diameter is in the range of 3 mm to 14 mm at the location in the tubing of at least one of the temperature sensor modules, preferably at least 50%, more preferably at least 90%, and particularly 100% of the
20 temperature sensor modules.

In embodiments, the tubing is metallic, preferably, one of a stainless steel, a duplex or super-duplex stainless steel, a nickel alloy, titanium or a titanium alloy. In embodiments, the tubing outer diameter is optionally in the range of 6 mm to 10 mm. Thus it should be clear in these embodiments that the invention is directed to the provision of apparatus for
25 measuring temperature downhole in a small diameter tubing.

In embodiments, the outer diameter of the tubing is the same at locations in the tubing of at least one or all of the temperature sensor modules and at locations in the tubing away from the at least one or all of the temperature sensor modules. In embodiments, the outer diameter of the tubing is not increased at the location in the tubing of at least one of
30 the temperature sensor modules, preferably at least 50%, more preferably at least 90%, and particularly 100% of the temperature sensor modules. By "at the location" we mean locations of the tubing over the length or of part of the length of the temperature sensor module. In embodiments, the external profile of the tubing is not changed at the location in the tubing of at least one of the temperature sensor modules, preferably at least 50%, more
35 preferably at least 90%, and particularly 100% of the temperature sensor modules. In

embodiments, the outer diameter of the tubing remains substantially constant along the tubing. By this we mean that, the outer diameter of the tubing neither increases nor decreases along the length of the tubing due to the presence or absence of temperature sensor modules. Of course, this does not exclude the outer diameter increasing due to
5 some other component provided in the tubing. In embodiments, the temperature sensor modules are configured to provide a smooth profile of the outer diameter of the tubing along the tubing. By providing a smooth profile, the tubing and apparatus can be more easily installed in the well. In accordance with these embodiments, lumps and changes in the shape and outer dimensions in the tubing due to the provision of the temperature sensor
10 modules can be avoided. This facilitates installation of the temperature sensing apparatus in a well, and allows the apparatus to be easily deployed in more restricted spaces and sealed against, which facilitates installation across packers. The smooth outer diameter tubing even allows the temperature sensor array to be clamped across guns provided to create perforations in the well and casing once ignited. The smooth outer diameter tubing array is
15 achievable by using resistive elements as the temperature sensor, which can be small in size, and by the provision of a majority of the control electronics in a control module at a location away from the temperature sensor modules in the tubing. This allows the temperature sensor array to be manufactured more easily, efficiently and cost effectively, and results in a shortened manufacturing lead time for the customer.

20 In embodiments, the resistive element is a resistance temperature device (RTD), particularly a platinum or nickel based RTD. RTD's are particularly suitable as they can provide a high level of repeatability.

In embodiments the RTD is constructed of a wire coil, a wound wire, or a thin-film, particularly a thin-film deposited on a ceramic substrate.

25 In embodiments the resistive element is a thermistor.

The use of thin-film RTDs and thermistors allows a robust apparatus for measuring temperature in a wellbore to be provided that can withstand pressure shockwaves induced, for example, by the ignition of shaped charges when firing perforation guns. Thus the apparatus can be mounted across, along, and or around perforating guns and run into the
30 well along with the perforating gun, giving valuable temperature measurements revealing information about fluid flow characteristics and gun effectiveness after perforations have been created thereby. In addition, the use of thin-film RTDs and thermistors temperature sensors permits small sensor modules to be embedded inside small diameter tubing, allowing the tubing to be created to have a small diameter and also a smooth outer profile,

without any bulges, so as to facilitate installation of the apparatus in a restricted annular space around the perforating gun, and across or beneath annular seals in the wellbore.

In embodiments, the tubing is filled with and encapsulates a non-conducting liquid, optionally an oil, and optionally wherein the tubing is comprises a pressure balancing means, optionally including a bellows or flexible bladder, configured to act to equalise internal pressure in the tubing with the ambient environment. In embodiments, the temperature sensor modules in the tubing are encased in a potting compound. Providing the temperature sensor modules in liquid-filled and optionally pressure-balanced tubing and/or encased in potting compound, such as an epoxy or thermos-set plastics or silicone rubber, increases the protection, e.g., against mechanical shock and pressure shockwaves and, for resistive temperature sensor components, can help withstand pressure shockwaves caused by the ignition of shaped charges by guns, e.g. to form perforations.

In embodiments, the tubing comprises at least 12 temperature sensor modules along its length, preferably at least 24 modules, more preferably at least 60 modules, and particularly at least 80 modules. The use of resistive temperature sensors in accordance with present invention facilitates the provision of large numbers of temperature sensor modules within and along a length of tubing, which may be served by a single or multiple control module or control sub-modules. This can provide sensitivity and a very high spatial resolution, or enable sensing over a very long distance.

In embodiments, the tubing comprises plural wires; and wherein the wires and plural temperature sensors are configured to provide an electrical network arranged as a matrix by which the wires comprise a first group of wires and a second, different group of wires and each wire of the first group is electrically connected to each wire of the second group once, by different temperature sensor modules, such that each module can be individually electrically connected by a pair of wires comprising a first wire from the first group and a second wire from the second group. This arrangement for connecting the temperature sensors allows a large number of temperature sensors to be coupled by and uniquely addressed or measured using the wires of the matrix. For example, for a typical 19 wire core, up to 90 temperature sensors can be coupled and measurements taken by connecting combinations of wire pairs.

In embodiments, the tubing comprises a matrix of at least 10 wires, preferably at least 15 wires, more preferably at least 18 wires, and in particular 19 wires.

In embodiments, the temperature sensor modules each comprise a diode arranged to block current from flowing back through the temperature sensor modules in the matrix.

In embodiments, the apparatus further comprises a control module (which may be one or more of the aforementioned control modules) electrically connected to the temperature sensor modules and configured to, in use, periodically switch through combinations of pairs of wires to electrically connect and infer a temperature at each of the temperature sensor modules. In embodiments, the control module comprises relays arranged to, in use, switch through the combinations of pairs of wires, wherein the relays are optionally electromechanical relays or semiconductor switches. In this way, the control module can automatically switch through and take measurements from the temperature sensors connected using the matrix.

In embodiments, the apparatus further comprises calibration means configured to compensate for the resistance of wires in the line that connect the resistance elements of the temperature sensors to the control module, and preferably also for the temperature dependence of the resistivity of those wires, wherein optionally the calibration means is provided as part of the control module. In embodiments, the calibration means is configured to achieve this resistance compensation by having, prior to use, measured the resistance of the wiring to each sensor at least 2 known temperatures to determine the resistance and temperature coefficient of the individual sensor wiring. These resistance and temperature coefficients of the individual sensor wiring are stored as calibration data in the calibration means. In use, the calibration means is configured to use the prior calibration data and the known temperature of segments of the wire to calculate the resistance of the wiring to a sensor at a point in time. Thus, in cases where a voltage applied to the temperature sensors is affected by the voltage drop over the wires and where this would affect the accuracy of the temperature measurements, the provision of the aforementioned calibrating means can compensate for the resistance of the wires and for the resultant voltage drops. This enables the control electronics to be provided distant from the temperature sensor modules, which allows the size of the temperature sensor modules to be kept small, allowing the temperature sensor modules to be provided inside a small diameter tubing while maintaining a smooth, bulge-free outer profile of the tubing. In embodiments, components of the above calibration means may be provided at the surface or configured such that certain operations, such as processing of data, may be carried out on the data at surface by components of the calibration means or other data processing means working together with the calibration means.

In embodiments, the control module further comprises a common reference signal generator used as a reference for the measurement of the voltage and/or current of at least two or each of temperature sensor modules. In embodiments, the common reference signal generator is a reference voltage source. Providing a common reference signal at the control

module for comparing the signal received from the temperature sensor modules (as opposed to providing multiple reference signal generators local to each temperature sensor module, where the reference signal would be subject to local variations due to, e.g., temperature differences, and drift) provides high inter-sensor accuracy and stability, with low drift. It also enables the relative changes of temperature between sensors to be detected more readily. In the downhole environment, particularly at elevated temperatures, drift of the reference and measurement circuit can frequently have a greater impact on temperature reading accuracy over time than drift of the sensor itself, provision of a common reference and measurement circuit eliminates the effect of this drift on inter-sensor accuracy.

10 In embodiments, the length of tubing containing the temperature sensors is between 0.25 to 10000 metres, more preferably 1 to 1000 metres, more preferably 10 to 200 metres. In embodiments, the tubing containing the temperature sensors is at least 0.25 metres long, preferably at least 1 metre long, more preferably at least 10 metres long. In embodiments, the tubing containing the temperature sensors is at most 10,000 metres long, preferably at most 1,000 metres long, more preferably at most 200 metres long.

In embodiments, multiple control modules are provided, wherein individual control modules control sets of temperature sensor modules, and the control modules are linked to one or more master control modules.

20 In embodiments, temperature sensor modules are spaced in the tubing at a spacing distance in the range 0.05 to 100 metres, more preferably 0.25 to 10 metres. The provision of a number of temperature sensor modules in the tubing allows a spacing to be selected to give an appropriate, and appropriately high or low spatial resolution.

In embodiments, the tubing containing the temperature sensor modules is arranged as a ring or helix to extend around a tubular element of a well apparatus. In accordance with this embodiment, temperature sensitivity dependent on the azimuthal angle around the tubular element (e.g. the drill, test or production, casing or liner string) can be provided, which can provide an indication of, e.g., an in-flow direction of product into a well bore or casing. Arranging such an apparatus around a gun can, after firing (where the apparatus is sufficiently robust to withstand the shock), provide information about the successful firing of the guns and creation of well perforations.

30 In embodiments, the apparatus further comprises a power source configured to provide operational power to the apparatus for sensing temperature in the wellbore in use, wherein the power source is arranged to be provided as an in-well power source in use. In embodiments, the power source comprises one or more primary cells, secondary cells and/or downhole power generators. In embodiments, the power source may be replaceable

in the well, for example the battery or power generator may be replaced using wireline, or coiled tubing.

In embodiments, the apparatus is configured to be powered in use from a position higher in the well, optionally from surface, and optionally via inductive or capacitive coupling.

5 In embodiments, the apparatus further comprises a wireless data communication module coupled to the apparatus for use in sensing temperature in a wellbore and arranged to, in use, wirelessly transmit along the well signals indicative of a temperature sensed in the wellbore by the apparatus, optionally using relays or repeaters. The wireless communication module may be coupled to the apparatus wirelessly, by a separate wireless connection, or
10 electrically by a wired connection and optionally also physically. In embodiments, the data communication can be by wired or wireless connections, or by both separately or in combination. In embodiments, where a power source is provided from a location higher in the well than the sensor array to power the sensor array, data from the control module may be transmitted by a wired connection up to the location of the in well power source, from
15 where the data may further be transmitted wirelessly from a wireless communication module. In embodiments, the wireless data communication module is configured to transmit said signals acoustically and/or electromagnetically. In accordance with these embodiments, the apparatus for sensing a temperature can be provided as an autonomous system downhole, in which cabling for providing power and/or communication capabilities does not need to be provided. By providing a local power source and wireless communication capabilities, the
20 apparatus for temperature sensing can be easily installed downhole in deep wells without having to run kilometres of cabling to the surface, through sealing elements, etc. By enabling data capture and recovery without having to recover the hardware, there is the option to discard the apparatus downhole after use. Alternatively, or in addition, the
25 apparatus may be configured to store and/or transmit sensor data. The storing of the sensor data may only be for a short period such as up to 1 second or 1 minute, 1 hour or 1 day, for example for the purposes of buffering, or alternatively or in addition, the storing of the sensor data may be for longer periods such as at least a day, at least a month at least a year, at least 2 years, or at least 5 years, for the purposes of long term data storage and subsequent
30 recovery, or partial recovery, wirelessly, by a wired connection or by physical retrieval.

In embodiments, the apparatus wireless data communication module is further arranged to receive control signals for controlling the operation of the apparatus. Alternatively, the apparatus may comprise further a wireless receiver, or transceiver arranged to receive control signals. The wireless receiver or transceiver may be provided as
35 part of the wireless communication module described above, or as a wireless control signal receiver/transceiver module which may be provided in the apparatus separately from the

above-described wireless control module. The operation of the apparatus may be controlled by the received signals. Control may include, control of data acquisition, data transmission, and/or to control heating or cooling of the sensors (as described in more detail below).

5 In embodiments, the temperature sensor module comprises an electronic circuit configured to vary at least one of a current, a voltage, and a frequency with a temperature of the sensor.

10 In embodiments, the apparatus is configured such that, in use, at least one temperature sensor module is selected by the control module digitally addressing the temperature sensor module, and wherein the selected temperature sensor module enables a voltage or current output representative of the temperature of a resistive element to be connected to the control module. Digital addressing of the temperature sensor modules allows the recovery of sensed temperature data at a control module coupled to the temperature sensor modules over lengths of electrical cabling without a need for an excessive number of cables.

15 In embodiments, the temperature sensor module comprises a flexible printed circuit, particularly a flexible printed circuit less than 1mm thick, and/or particularly a flexible printed circuit comprising a polyimide or a polyaryletherketone substrate. Use of a flexible printed circuit enables multiple components to be mounted together within the confines of a small tube and facilitates coiling of the tube prior to, or at deployment. Polyimide and
20 polyaryletherketone (for example polyether ether ketone, PEEK) substrates are advantageous as they combine high strength with high operating temperatures. In embodiments the flexible printed circuit may comprise a rigid-flex printed circuit. A rigid-flex printed circuit combines flexible elements with rigid elements, rigid elements are particularly beneficial within a temperature sensor module to reduce stresses on the bonds between
25 components and the printed circuit, whilst flexible elements permit bending of the outer tube without applying significant stress to the rigid elements. Additionally use of a flexible printed circuit may also permit multiple sensor modules, and/or the connection between sensor modules and sensor modules to be combined on a single flexible printed circuit, thus enabling more cost effective manufacture and a reduction in interconnects which may be
30 prone to failure. References to wire included herein, may include wiring constructed as a flexible printed circuit.

In embodiments, at least one, or each temperature sensor module comprises a single integrated electronic component incorporating the resistive element. That is, the functional components of the temperature sensor module that provide the sensitivity are in
35 embodiments provided by only a single electronic component, however the temperature

sensor modules may also comprise other, non-electronic components, such as packaging and electrical interconnects, that do not contribute functionally to the temperature sensitivity. The temperature sensor module may include other non-electronic components, such as electrical components providing interconnects, and packaging for the module. Using a
5 single electronic component to provide the temperature sensitivity of the temperature sensitive components of the apparatus facilitates the installation of the temperature sensitive modules in a small outer diameter tubing (as low as 3-14mm tubing) while also allowing the outer diameter of the tubing to remain smooth and relatively constant at locations along the whole or at least part of the length of the temperature sensor modules and at locations in the
10 tubing away from the temperature sensor modules. The installation of the single electronic component temperature sensor modules in the small outer diameter tubing also makes the manufacture of the apparatus cheaper and relatively easy to process and manufacture (no larger diameter components need to be manufactured and welded to the tubing), and also to install.

15 In embodiments, the maximum physical extent of the single electronic component in any axis is less than 7mm, preferably less than 5mm, more preferably less than 4mm, even more preferably less than 3mm. The use of certain resistive temperature sensors, such as bead thermistors, enables the use of very small temperature sensitive components, allowing the temperature sensor modules to also be small. This allows the modules to be easily
20 embedded in the tubing in a space-efficient manner. In embodiments, the single electronic component has a very low mass (excluding extraneous packaging and interconnects), optionally less than 1g, optionally less than 500mg, optionally less than 250mg, optionally less than 150mg, optionally less than 50mg. Providing the temperature sensor module comprising a single, small, low mass, electronic component to provide the temperature
25 sensitivity provides a very robust apparatus as the low mass of the components results in them being able to withstand higher acceleration, for example, from the ignition of guns to create perforations. Also, the structural integrity of the small, low mass components is relatively high. Thus the apparatus can be provided across guns and can withstand their ignition and reliably continue to operate to provide temperature sensor data after ignition of
30 the charges.

In embodiments, the control module is configured to measure an analogue current, voltage and/or frequency associated with the temperature sensor modules to enable inference of the temperature of the resistive elements and the environment to which the tubing is exposed at the location of that resistive element. The analogue sensing of an
35 electrical characteristic of the circuit including the temperature sensor modules at the control module, e.g. addressing the temperature sensor modules using a matrix, provides an

elegant and effective means of temperature measurement, and also allows the temperature sensor modules to have an elegant construction, avoiding the need for any local digital components, and is particularly suited to be used along with a common reference at the control module.

5 In other embodiments, the temperature sensor modules are configured to, in use, encode and transmit a digital signal to the control module indicative of the temperature-sensitive electrical property of the resistive element, and wherein the control module is configured to, in use, determine a sensed temperature at each temperature sensor using said received digital signals. In embodiments, a plurality of or optionally all of the
10 temperature sensors are configured to transmit digital signals to the control module using the same wire. In embodiments, the control module is configured to measure the digital signals associated with the temperature sensor modules to enable inference of the temperature of the resistive elements and the environment to which the tubing is exposed at the location of that resistive element. Digital encoding of a locally sensed electrical characteristic of the
15 resistive temperature-sensitive element allows a simple, reliable and effective means of capturing and conveying the temperature information from the temperature sensor modules to the control module without needing a large number of wires. In addition, the use of digital encoding allows an increasing number of temperature sensor modules to be added to an apparatus for sensing temperature downhole by connecting them in parallel them in a tubing
20 by connection via the same wiring to the control module. A single wire may be used for signalling, which may be the same wire as one that powers the temperature sensor modules.

Viewed from another aspect, the present invention provides a well comprising a well apparatus having apparatus for use in sensing temperature in a wellbore as described in accordance with the above aspect and embodiments of the invention, the apparatus being
25 arranged to sense a temperature in a wellbore of the well. In embodiments, the well apparatus comprises a tubular element and an annular sealing device provided at least 100m below a surface of the well, and between the wellbore or a casing of the wellbore and a tubular. The annular sealing device is a device which seals between two tubulars (or a tubular and the wellbore), such as a polished bore and seal assembly or a packer element.
30 The seal assembly may be associated with a polished bore sub in a casing or liner. The packer element may be part of a packer, bridge plug, or liner hanger, especially a packer or bridge plug. The annular sealing device may be arranged, e.g., to seal the flow of fluid between a well casing and a test or production string. In this respect, the temperature sensing apparatus may be used in the production zone of the well below the surface
35 proximal to a formation for sensing temperature variations due to, e.g. the flow of product

and other fluids, rather than being used near the well-head to sense temperature there for another purpose.

In embodiments, the apparatus for use in sensing temperature in a wellbore is provided entirely below the annular sealing device. In embodiments, the tubing of the apparatus for use in sensing temperature in a wellbore does not extend across the annular sealing device. In embodiments, the tubing of the apparatus for use in sensing temperature in a wellbore is provided below and extending across the annular sealing device, and wherein a control module of the apparatus for use in sensing temperature is provided in the wellbore below the annular sealing device. In this respect, the apparatus for using in sensing temperature in a wellbore may be provided as a fully autonomous system operating as a self-powered unit, below an annular sealing device, without having to provide power and/or communication cabling across the annular sealing device e.g. from the surface.

In embodiments, the tubing of the apparatus for use in sensing temperature in a wellbore is provided below and extending across the annular sealing device, and wherein a control module of the apparatus for use in sensing temperature is provided in the wellbore above the annular sealing device. The apparatus may still be provided downhole as an autonomous system.

In embodiments, a control module of the apparatus for use in sensing temperature in a wellbore is located at the end of the tubing, optionally at the end of the tubing nearest the surface, optionally below the annular sealing device.

In embodiments, the apparatus further comprises communication means within the tubing to enable data communication along the tubing, for instance additional wire(s) may be provided to enable communication between control modules, or to enable communication with other devices within the well.

In embodiments, the well apparatus comprises a tubular element and wherein the tubing of the apparatus for use in sensing temperature in a wellbore extends along and/or around the tubular element. In embodiments, the tubular element is one of a generally tubular drill string, a test string, a completion string, a production string (e.g. the production tubing thereof), an injection string, a work-over string, an observation string, a suspension string, an abandonment string, a casing string, a screen or a liner. Strings may comprise multiple elements such as pipe, valves, collars, subs, etc., some minor elements of which may not be tubular. In embodiments, the tubing is clamped to the tubular element in the well, by which clamping is intended to be understood to include securing by other means, for example, by taping, strapping, bolting, gluing. In embodiments, the apparatus is deployed in the well on wireline, or coiled tubing, and optionally set and/or suspended in the well. The

apparatus may be deployed in the well for an extended period of time, optionally at least 1 week, optionally at least 1 month, optionally at least 6 months, optionally at least 1 year, optionally at least 2 years, optionally up to 5 years, to monitor the temperature of the well. Data from the apparatus can enable the inference of flow rates, and can be used to identify the type of fluid and location of fluid entry, and when used to monitor a barrier can determine the presence or absence of leaks.

In embodiments, the tubing is clamped to and extends across a perforating gun or guns. In this embodiment, the apparatus for use in sensing a temperature in a wellbore can be run in together with guns and, as it is robust enough to withstand the pressure shockwave, the apparatus is then arranged to provide temperature sensing information before, during and after perforation of the well using the guns. The apparatus, or multiple apparatuses, may be deployed along multiple independently activated perforating guns, and thus provide information on changing downhole conditions, as each perforating gun is activated.

In embodiments, the apparatus for use in sensing a temperature in a wellbore can be run in to the well such that the tubing of the apparatus is in a groove on an element of the string, such as a tubular of the well, perforating gun, screen, carrier, sub or packer.

In embodiments, the apparatus can be deployed at a barrier in the well such as a packer, bridge plug, cement, resin, or rigid or flexible plugging material. Data from the apparatus can be used to confirm the integrity of the barrier, there will generally be a temperature change associated with any leak. The apparatus may be deployed around, above, below, and/or within the barrier,

In embodiments, the apparatus for use in sensing a temperature in a wellbore can be deployed in a subsea well. This is particularly advantageous for embodiments with memory and/or wireless capability, as the additional complexity, cost, and risk associated with the use of cabled monitoring systems is especially significant in subsea wells.

Viewed from another aspect, the present invention provides a method of calibrating apparatus for use in sensing temperature in a wellbore as described in relation to the above aspect and embodiments, the method comprising: determining the resistance characteristics of the individual circuits associated with each temperature sensor of the apparatus, and compensating for that circuit resistance to isolate the responsiveness of the electrical properties of the temperature sensors to temperature variations. In this way, the resistance of the wires, and the temperature sensitivity thereof, can be compensated for, e.g. where the voltage drop of a platinum resistance sensor is being measured at the end of long lines and

where the voltage drop along the lines (and where the temperature sensitivity thereof) becomes significant.

Viewed from another aspect, the present invention provides a method of operation of apparatus as described in relation to the above aspect and embodiments, to determine a thermal characteristic of a temperature sensor thereof, the method comprising: actively heating and/or cooling at least one of the temperature sensors in the tubing; and monitoring a change of temperature of the, or each, sensor during and/or after heating and/or cooling. In embodiments, the method further comprises, based on the change of temperature, or on a rate of change of temperature, or the power to create a change in temperature of the sensors during and/or after heating, inferring a fluid characteristic (such as flow rate or an identification of the type of component fluids in the well) of the environment to which the tubing is exposed at the locations of the temperature sensors. In embodiments, actively heating at least one temperature sensor in the tubing comprises self-heating the sensors by applying a current therethrough. In embodiments, at least one temperature sensor of the apparatus is heated by applying a current through a resistor or resistance associated with the temperature sensor module. In this way, the temperature sensitivity of the temperature sensor modules and their relative or absolute response to changes in temperature (e.g. by actively heating the sensors, or by sensing ambient changes in temperature) can be used to indicate and provide information usable to infer the operational conditions of the well. For example, when oil enters the well there may be a heating effect, and when water enters the well there may be an even greater heating effect. Conversely, when gas enters the well there is generally a cooling effect. The temperature measured may be of the flow entering the well, or of the combined fluid flow within an annulus or bore. The variation of temperature, and rate of heating and cooling can be used to infer the flow rates and components of fluid in the well. Additionally active heating of the sensors can further assist in identifying fluid types as the heating on the sensors will be affected by the thermal mass of the surrounding fluid, particularly at low flow rates and in static conditions.

The apparatus can be used in at least one of different phases of well life including drilling, testing, completion, production/injection, fracturing, work-over, observation, suspension, and abandonment, to sense temperature along the wellbore and infer fluid characteristics. The apparatus may be deployed on the outside of casing, or liner, or screens, or within a gravel pack, or on tubulars in cased or open-hole. The apparatus may be used to monitor production from, or injection to, cross-flow within, or fluid treatment of a well or reservoir.

Where 'across' is used in this patent in the context of the tubing, where appropriate it may be interpreted as across, along, or around, that is it may run the partial, entire, or extend beyond the length of an associated tubular, and/or be wrapped around said tubular in a ring or helix.

5 **BRIEF DESCRIPTION OF THE DRAWINGS**

Aspects of the invention will now be described in more detail in relation to certain exemplary embodiments, with reference to the accompanying drawings, in which:

Figure 1 shows a schematic illustration of an embodiment of an apparatus for use in sensing temperature in a wellbore comprising resistive temperature sensors in accordance
10 with aspects of the present invention;

Figure 2 shows a schematic illustration of a typical deployment of the apparatus shown in Figure 1 in a subsea well;

Figure 3 shows a schematic illustration of an arrangement for the construction and operation of the resistive temperature sensor modules and the control module of an
15 apparatus as shown in Figure 1 to sense temperature, address the sensor modules, and to process and recover temperature information therefrom in accordance with another embodiment where local references are used;

Figure 4 shows a schematic illustration of an arrangement for the construction and operation of the resistive temperature sensor modules and the control module of an
20 apparatus as shown in Figure 1 to sense temperature, address the sensor modules, and to process and recover temperature information therefrom in accordance with another embodiment where a common reference is used;

Figure 5 shows a schematic illustration of an arrangement for the apparatus in accordance with one embodiment for digitally connecting the resistive temperature sensor
25 modules to the control module using a power rail wire;

Figure 6 shows a schematic illustration of an arrangement for the apparatus in accordance with another embodiment for digitally connecting the resistive temperature sensor modules to the control module using a common third wire;

Figure 7 shows a schematic illustration of an arrangement for the apparatus in
30 accordance with an embodiment for connecting the resistive temperature sensor modules to the control module to receive an analogue signal therefrom using individual wires;

Figure 8 shows a schematic illustration of an arrangement for the apparatus in accordance with another embodiment for connecting the resistive temperature sensor modules to the control module to receive an analogue signal therefrom using first and second groups of wires arranged as a matrix;

- 5 Figure 9 is a process flow diagram showing a method of operation of apparatus described above in relation to Figures 1- 8 to determine a temperature along a wellbore.

DESCRIPTION OF THE EMBODIMENTS

Referring now to Figure 1, embodiments in accordance with aspects of the invention provide apparatus 100 for use in sensing temperature in a wellbore. As will be explained in more detail in relation to Figure 2, the apparatus 100 is to be placed in a wellbore e.g. during a well test, to sense a temperature therein and to communicate the temperature sensed thereby to the surface.

The apparatus 100 comprises tubing 110 comprising a plurality of temperature sensor modules 120a, 120b, 120c ... 120n provided at locations along the inside of the tubing 110. As will be explained in more detail below, the temperature sensor modules 120a, 120b, 120c ... 120n each comprise a temperature sensor having electrical properties that vary with temperature.

In embodiments, the tubing 110 is metallic, preferably, one of a stainless steel, a duplex or super-duplex stainless steel, a nickel alloy, titanium or a titanium alloy. In embodiments, the tubing outer diameter is in the range of 3 mm to 14 mm. A smaller diameter tubing, such as a 6mm (1/4 inch) tubing, may be used for normal deployments. Where a more robust system is needed, for example to withstand pressure shockwaves of guns for perforating casing, a larger diameter tubing, such as a 10mm (3/8 inch) tubing may be used. The tubing 110 is filled with and encapsulates a non-conducting oil 111 that acts to protect the temperature sensor modules 120a, 120b, 120c ... 120n, particularly from pressure shockwaves. The tubing 110 comprises a bellows 112 configured to act as pressure balancing means to equalise internal pressure in the tubing with the ambient environment. To provide further protection from pressure shockwaves (such as from guns) and from the ambient environment the temperature sensor modules 120a, 120b, 120c ... 120n are encased in a polyurethane resin or another suitable potting compound such as a thermoset plastic, epoxy resin or a silicone or rubber gel.

As can be seen from the schematic illustration of Figure 1, the outer profile of the tubing 110 remains substantially constant along the length of the tubing 110 insofar as that all of the temperature sensor modules 120a, 120b, 120c ... 120n do not cause the tubing 110

to need to have a larger diameter at the location of the sensors in order to accommodate them. Rather, the temperature sensor modules 120a, 120b, 120c ... 120n are accommodated inside the tubing. In embodiments, the tubing profile may vary for other reasons (e.g. the presence of other components, or to allow connection of other components to the tubing 110) but generally the temperature sensor modules 120 at least do not cause the outer profile or diameter of the tubing 110 to vary.

The temperature sensor modules 120a, 120b, 120c ... 120n are electrically connected to an electrical network 115 to in use allow measuring of the respective electrical properties of the temperature sensors to infer a thermal characteristic thereof. The apparatus 100 further comprises a control module 130 that electrically connected to the temperature sensor modules 120a, 120b, 120c ... 120n via the electrical network 115. The control module 130 is arranged to in use receive and process an electrical signal associated with the temperature sensor modules 120a, 120b, 120c ... 120n to enable inference of the temperature thereof and the environment to which the tubing is exposed at the location of that temperature sensor module. A resistive heating element (not shown) may be provided in the tubing 110 alongside temperature sensor modules 120a, 120b, 120c ... 120n to heat the temperature sensor modules 120a, 120b, 120c ... 120n in use in order to gauge, e.g. a heating or cooling effect by a flow of the surrounding fluid in the wellbore. Where a separate heating element is not provided, other suitable mechanisms for heating the temperature sensor modules 120a, 120b, 120c ... 120n, such as self heating by applying a high current through the resistive sensing element, may be used.

The apparatus 100 also comprises a power source 140 and a communications module 150 that are provided together with the control module 130 in a module housing 160. The module housing 160 is provided at an end of tubing 110, and the tubing 110 is coupled thereto. The module housing 160 may have more than one length of tubing 110 containing temperature sensor modules extending therefrom. For example, the module housing 160 may have picked up tubing 110 extending from opposite sides thereof such that it is provided the middle of the apparatus 100 for sensing temperature along a wellbore. In the embodiment shown, a single control module 150 is provided. In alternative embodiments, multiple control modules may be provided, wherein individual control modules control sets of temperature sensor modules, and the control modules may be linked to one or more master control modules.

The power source 140 is coupled to the control module 130, temperature sensor modules 120a, 120b, 120c ... 120n via the control module 130, and the communications module 150, and is configured to provide operational electrical power thereto in use. The power source

140 is arranged to be provided as an in-well power source (i.e. the power is generated or sourced locally to the apparatus in the well, preferably without any wired link to a remote power source) in use and is provided as a battery pack comprising a plurality of primary cells, such as lithium-based cells, which provide capacity sufficient to power the apparatus
5 100 throughout its usable life. Alternatively, or in addition, in other embodiments the power source 140 may also comprise secondary, rechargeable cells, and/or a downhole power generation unit, such as a turbine. The battery may be at least one of a high temperature lithium thionyl chloride battery and a lithium sulphuryl chloride battery. High temperature batteries are those operable above 85°C and sometimes above 100 °C. Further still, in
10 other implementations the apparatus 100 may alternatively or in addition be configured to be powered in use from a remote power source coupled wirelessly, e.g., by via inductive or capacitive coupling, such that the downhole power source 140 may or may not need to be provided. In use, the remote power source may be located at a position higher in the well, or at the surface.

15
The communications module 150 is configured to transmit, in use, e.g. to the surface, signals indicative of a temperature sensed in the wellbore by one or more temperature sensor modules 120a, 120b, 120c ... 120n of the apparatus. The transmitted signals indicative of a temperature sensed in the wellbore may be immediately representative of the
20 measured temperatures (whether that is absolute or relative temperatures), meaning that the control module 130 has performed processing to evaluate the temperature data, although further processing of the temperature data may still be needed at the surface to refine or analyse the results. Alternatively, the transmitted signals indicative of a temperature sensed in the wellbore may be in a more “raw” form and require further processing at the surface in
25 order to reveal the measured temperatures (whether that is absolute or relative temperatures).

The communications module 150 is a wireless data communication module arranged to, in use, wirelessly transmit along the well the signals indicative of a temperature sensed in the wellbore by the apparatus.

30 Preferably the wireless signals are such that they are capable of passing through a barrier, such as a plug, when fixed in place. Preferably therefore the wireless signals are transmitted in at least one of the following forms: electromagnetic (EM), acoustic, coded pressure pulsing and inductively coupled tubulars.

The signals may be data or control signals which need not be in the same wireless
35 form. Accordingly, the options set out herein for different types of wireless signals are

independently applicable to data and control signals. The control signals can control downhole devices including sensors. Data from sensors may be transmitted in response to a control signal. Moreover data acquisition and/or transmission parameters, such as acquisition and/or transmission rate or resolution, may be varied using suitable control signals.

EM/Acoustic and coded pressure pulsing use the well, borehole or formation as the medium of transmission. The EM/acoustic or pressure signal may be sent from the well, or from the surface. If provided in the well, an EM/acoustic signal can travel through any annular sealing device, although for certain embodiments, it may travel indirectly, for example around any annular sealing device.

Electromagnetic and acoustic signals are especially preferred - they can transmit through/past an annular sealing device or annular barrier without special inductively coupled tubulars infrastructure, and for data transmission, the amount of information that can be transmitted is normally higher compared to coded pressure pulsing, especially receiving information, such as data, from the well.

Therefore, the communication device may comprise an acoustic communication device and the wireless control signal comprises an acoustic control signal and/or the communication device may comprise an electromagnetic communication device and the wireless control signal comprises an electromagnetic control signal.

Similarly the transmitters and receivers used correspond with the type of wireless signals used. For example an acoustic transmitter and receiver are used if acoustic signals are used.

Thus, the EM/acoustic or pressure wireless signals can be conveyed a relatively long distance as wireless signals, sent for at least 200m, optionally more than 400m or longer which is a clear benefit over other short range signals. Embodiments including inductively coupled tubulars provide this advantage/effect by the combination of the integral wire and the inductive couplings. The distance travelled may be much longer, depending on the length of the well.

The control signal, and optionally other signals, may be sent in wireless form from above the annular sealing device to below the annular sealing device. Likewise signals may be sent from below the annular sealing device to above the annular sealing device in wireless form.

Data and commands within the signal may be relayed or transmitted by other means. Thus the wireless signals could be converted to other types of wireless or wired signals, and optionally relayed, by the same or by other means, such as hydraulic, electrical and fibre optic lines. In one embodiment, the signals may be transmitted through a cable for a first distance, such as over 400m, and then transmitted via acoustic or EM communications for a

smaller distance, such as 200m. In another embodiment they are transmitted for 500m using coded pressure pulsing and then 1000m using a hydraulic line.

Thus whilst non-wireless means may be used to transmit the signal in addition to the wireless means, preferred configurations preferentially use wireless communication. Thus, whilst the distance travelled by the signal is dependent on the depth of the well, often the wireless signal, including relays but not including any non-wireless transmission, travel for more than 1000m or more than 2000m. Preferred embodiments also have signals transferred by wireless signals (including relays but not including non-wireless means) at least half the distance from the surface of the well to the apparatus.

Different wireless signals may be used in the same well for communications going from the well towards the surface, and for communications going from the surface into the well.

Thus, the wireless signal may be sent to the communication device, directly or indirectly, for example making use of in-well relays above and/or below any annular sealing device. The wireless signal may be sent from the surface or from a wireline/coiled tubing (or tractor) run probe at any point in the well above any annular sealing device. For certain embodiments, the probe may be positioned relatively close to any annular sealing device for example less than 30m therefrom, or less than 15m.

The abovementioned wireless signal transmission techniques will now be briefly described in turn.

Inductively Coupled Tubulars

Where inductively coupled tubulars are used, there are normally at least ten, usually many more, individual lengths of inductively coupled tubular which are joined together in use, to form a string of inductively coupled tubulars. They have an integral wire and may be formed of tubulars such as tubing drill pipe or casing. At each connection between adjacent lengths there is an inductive coupling. The inductively coupled tubulars that may be used can be provided by N O V under the brand Intellipipe®.

Coded Pressure Pulses

Pressure pulses include methods of communicating from/to within the well/borehole, from/to at least one of a further location within the well/borehole, and the surface of the well/borehole, using positive and/or negative pressure changes, and/or flow rate changes of a fluid in a tubular and/or annular space.

Coded pressure pulses are such pressure pulses where a modulation scheme has been used to encode commands and/or data within the pressure or flow rate variations and a transducer is used within the well/borehole to detect and/or generate the variations, and/or

an electronic system is used within the well/borehole to encode and/or decode commands and/or the data. Therefore, pressure pulses used with an in-well/borehole electronic interface are herein defined as coded pressure pulses.

Where coded pressure pulses are used to transmit control signals, various
5 modulation schemes may be used to encode data such as rate of pressure change, on/off keyed (OOK), pulse position modulation (PPM), pulse width modulation (PWM), frequency shift keying (FSK), pressure shift keying (PSK), amplitude shift keying (ASK), combinations of modulation schemes may also be used, for example, OOK-PPM-PWM. Data rates for
10 coded pressure modulation schemes are generally low, typically less than 10bps, and may be less than 0.1 bps. An advantage of coded pressure pulses, as defined herein, is that they can be sent to electronic interfaces and may provide greater data rate and/or bandwidth than pressure pulses sent to mechanical interfaces.

Coded pressure pulses can be induced in static or flowing fluids and may be detected by directly or indirectly measuring changes in pressure and/or flow rate. Fluids
15 include liquids, gasses and multiphase fluids, and may be static control fluids, and/or fluids being produced from or injected in to the well.

Acoustic

Acoustic signals and communication may include transmission through vibration of
20 the structure of the well including tubulars, casing, liner, drill pipe, drill collars, tubing, coil tubing, sucker rod, downhole tools; transmission via fluid (including through gas), including transmission through fluids in uncased sections of the well, within tubulars, and within annular spaces; transmission through static or flowing fluids; mechanical transmission through wireline, slickline or coiled rod; transmission through the earth; transmission through
25 wellhead equipment. Communication through the structure and/or through the fluid are preferred.

Acoustic transmission may be at sub-sonic (<20 Hz), sonic (20 Hz – 20kHz), and ultrasonic frequencies (20kHz – 2MHz). Preferably the acoustic transmission is sonic (20Hz – 20khz).

30 The acoustic signals and communications may include Frequency Shift Keying (FSK) and/or Phase Shift Keying (PSK) modulation methods, and/or more advanced derivatives of these methods, such as Quadrature Phase Shift Keying (QPSK) or Quadrature Amplitude Modulation (QAM), and preferably incorporating Spread Spectrum Techniques. Typically they are adapted to automatically tune acoustic signalling frequencies and methods to suit
35 well conditions.

The acoustic signals and communications may be uni-directional or bi-directional. Piezoelectric, moving coil transducer or magnetostrictive transducers may be used to send and/or receive the signal.

5 EM

Electromagnetic (EM) (sometimes referred to as Quasi-Static (QS)) wireless communication is normally in the frequency bands of: (selected based on propagation characteristics)

sub-ELF (extremely low frequency) <3Hz (normally above 0.01Hz);

10 ELF 3Hz to 30Hz;

SLF (super low frequency) 30Hz to 300Hz;

ULF (ultra low frequency) 300Hz to 3kHz; and,

VLF (very low frequency) 3kHz to 30kHz.

15 An exception to the above frequencies is EM communication using the pipe as a wave guide, particularly, but not exclusively when the pipe is gas filled, in which case frequencies from 30kHz to 30GHz may typically be used dependent on the pipe size, the fluid in the pipe, and the range of communication. The fluid in the pipe is preferably non-conductive. US 5,831,549 describes a telemetry system involving gigahertz transmission in a
20 gas filled tubular waveguide.

Sub-ELF and/or ELF are preferred for communications from a well to the surface (e.g. over a distance of above 100m). For more local communications, for example less than 10m, VLF is preferred. The nomenclature used for these ranges is defined by the International Telecommunication Union (ITU).

25 EM communications may include transmitting data by one or more of the following: imposing a modulated current on an elongate member and using the earth as return; transmitting current in one tubular and providing a return path in a second tubular; use of a second well as part of a current path; near-field or far-field transmission; creating a current loop within a portion of the well metalwork in order to create a potential difference between
30 the metalwork and earth; use of spaced contacts to create an electric dipole transmitter; use of a toroidal transformer to impose current in the well metalwork; use of an insulating sub; a coil antenna to create a modulated time varying magnetic field for local or through formation transmission; transmission within the well casing; use of the elongate member and earth as a coaxial transmission line; use of a tubular as a wave guide; transmission outwith the well
35 casing.

Especially useful is imposing a modulated current on an elongate member and using the earth as return; creating a current loop within a portion of the well metalwork in order to

create a potential difference between the metalwork and earth; use of spaced contacts to create an electric dipole transmitter; and use of a toroidal transformer to impose current in the well metalwork.

To control and direct current advantageously, a number of different techniques may be used. For example one or more of: use of an insulating coating or spacers on well tubulars; selection of well control fluids or cements within or outwith tubulars to electrically conduct with or insulate tubulars; use of a toroid of high magnetic permeability to create inductance and hence an impedance; use of an insulated wire, cable or insulated elongate conductor for part of the transmission path or antenna; use of a tubular as a circular waveguide, using SHF (3GHz to 30 GHz) and UHF (300MHz to 3GHz) frequency bands.

Suitable means for receiving the transmitted signal are also provided, these may include detection of a current flow; detection of a potential difference; use of a dipole antenna; use of a coil antenna; use of a toroidal transformer; use of a Hall effect or similar magnetic field detector; use of sections of the well metalwork as part of a dipole antenna.

Where the phrase "elongate member" is used, for the purposes of EM transmission, this could also mean any elongate electrical conductor including: liner; casing; tubing or tubular; coil tubing; sucker rod; wireline; slickline or coiled rod.

A means to communicate signals within a well with electrically conductive casing is disclosed in US 5,394,141 by Soulier and US 5,576,703 by MacLeod et al both of which are incorporated herein by reference in their entirety. A transmitter comprising oscillator and power amplifier is connected to spaced contacts at a first location inside the finite resistivity casing to form an electric dipole due to the potential difference created by the current flowing between the contacts as a primary load for the power amplifier. This potential difference creates an electric field external to the dipole which can be detected by either a second pair of spaced contacts and amplifier at a second location due to resulting current flow in the casing or alternatively at the surface between a wellhead and an earth reference electrode.

Relay

A relay comprises a transceiver (or receiver) which can receive a signal, and an amplifier which amplifies the signal for the transceiver (or a transmitter) to transmit it onwards.

There may be at least one relay. The at least one relay (and the transceivers or transmitters associated with the apparatus or at the surface) may be operable to transmit a signal for at least 200m through the well. One or more relays may be configured to transmit for over 300m, or over 400m.

For acoustic communication there may be more than five, or more than ten relays, depending on the depth of the well and the position of the apparatus.

Generally, less relays are required for EM communications. For example, there may be only a single relay. Optionally therefore, an EM relay (and the transceivers or transmitters associated with the apparatus or at the surface) may be configured to transmit for over 500m, or over 1000m.

5 The transmission may be more inhibited in some areas of the well, for example when transmitting across a packer. In this case, the relayed signal may travel a shorter distance. However, where a plurality of acoustic relays are provided, preferably at least three are operable to transmit a signal for at least 200m through the well.

10 For inductively coupled pipe, a relay may also be provided, for example every 300 – 500m in the well.

The relays may keep at least a proportion of the data for later retrieval in a suitable memory means.

Taking these factors into account, and also the nature of the well, the relays can therefore be spaced apart accordingly in the well.

15 The wireless signals may cause, in effect, immediate activation, or may be configured to activate the apparatus after a time delay, and/or if other conditions are present such as a particular pressure change.

The apparatus 100, in particular temperature sensor modules 120a...n, the control module 130 and/or the communications module 150, may comprises one or more
20 microprocessors. Electronics in the apparatus, to power various components such as the microprocessor, control and communication systems, are preferably low power electronics. Low power electronics can incorporate features such as low voltage microcontrollers, and the use of 'sleep' modes where the majority of the electronic systems are powered off and a low frequency oscillator, such as a 10 – 100kHz, for example 32kHz, oscillator used to
25 maintain system timing and 'wake-up' functions. Synchronised short range wireless (for example EM in the VLF range) communication techniques can be used between different components of the system to minimize the time that individual components need to be kept 'awake', and hence maximise 'sleep' time and power saving.

30 The low power electronics facilitates long term use of various components of the apparatus. The control mechanism may be configured to be controllable by the wireless control signal up to more than 24 hours after being run into the well, optionally more than 7 days, more than 1 month, or more than 1 year or more than 5 years. It can be configured to remain dormant before and/or after being activated.

In this way, by the use of an in-well power source 140 and a wireless
35 communications module 150 and/or a memory device for wirelessly conveying/locally storing data including sensor data, the apparatus 100 for use in sensing a temperature along a well-

bore may be configured to operate as an “autonomous” system downhole. The apparatus may include one or more housings or enclosures supporting one or more of the in-well power source 140, wireless communications module 150 and/or memory device such that it is configured as an autonomous system for installation downhole. In these configurations, the apparatus may, in use, require no cabling to receive power from or transmit signals to the surface. This means that the apparatus 100 can be reliable and easy to deploy, and in addition, where only a short section of the well is being measured, cabling and apparatus needs only to be provided in the region of the well under test. That is unlike the prior art fibre optic temperature sensor systems and the WellWatcher Flux™ in which cabling needs to be provided all the way from the sensed location to the surface, which can be incredibly inconvenient and problematic where, for example, the temperature of a short section of the well (say 20m long) needs to be tested at a well depth of greater than 500m, which itself is subsea at a depth of 3km from the water surface. Using the apparatus 100, only a short, 20m long length of tubing 110 and the module housing 160 needs to be provided in the well, whereas in the prior art, cabling over 3.5km is needed to obtain a sensed temperature in the 20m section of the wellbore.

In that respect, the tubing 110 is typically 10 to 200 metres in length, and the temperature sensor modules are typically spaced in the tubing at a spacing distance in the range 0.25 to 10 metres. The length of the tubing and spacing of the sensor modules can be chosen so as to obtain a desired measurement span and spatial resolution. While the tubing 110 shown in Figure 1 is “straight” in that it is arranged to extend along the wellbore substantially along the axis of the wellbore, in other embodiments the tubing 110 can be arranged as a ring or helix to extend around a tubular element of a well apparatus. Here, the tubing length and/or sensor spacing can be shorter, and the apparatus in this arrangement can reveal information about the azimuthal variation in sensed temperature at locations in the wellbore, which can be reveal information about a direction of flow of fluid in the wellbore.

Reference will now be made to Figure 2, which shows a typical deployment of the apparatus 100 shown in Figure 1 in a subsea well 200.

The well 200 comprises a wellbore 201 that has been drilled using a drillship or semisubmersible rig and which has been subsequently lined and cased (not shown). By wellbore in this disclosure it is meant, as necessary, the inward-facing wall of a drilled openhole well, or the or part of the void defined thereby, or, as context requires, even the inward-facing surface of a casing of a cased well, or the or part of the void defined thereby. The wellbore 201 is often an at least partially vertical well. Nevertheless, it can be a

deviated or horizontal well. References such as “above” and below” when applied to deviated or horizontal wells should be construed as their equivalent in wells with some vertical orientation. For example, “above” is closer to the surface of the well.

5 A drill stem test is now being performed using a tubular element provided by a drill stem test (DST) string 210 in which the drill bit has been removed from the drill string and replaced with testing and sensing equipment as a sensor string 210 run into the well to assess the geological formation 220.

10 A redeployable packer is provided as an annular seal 230 arranged above a formation 220 to be tested. A gun module 240 comprising a series of shaped charges is provided in the string 210 which, in use, is fired to form perforations 225 through the casing and into the formation 220 to stimulate a flow of product.

15 The apparatus 100 shown in Figure 1 for sensing a temperature in a wellbore is provided in the DST string 210 arranged below the annular sealing device 230 such that the tubing 110 is not required to traverse the seal. The module housing 160 is annularly configured to permit flow there through and is arranged in the string 210 below the annular seal 230 and the tubing 110 runs along the outer surface of the string 210 (e.g. in a groove) along the wellbore and across guns and is clamped thereto using clamps 250. The clamps 250 may be configured to act as straps, to strap the tubing 110 to the string 210. Further clamps (not shown) may be provided, in particular, along the perforating gun, to ensure that
20 the tubing is retained clear of the perforating charges.

A ported sleeve 260 is provided, opening the cased hole into the tubular element of the drill string 210, through which, upon opening of the valve 265, product is permitted to flow under pressure from the perforations 225 in the formation 220 into the tubular element of the DST string 210 to the wellhead 280, which is sealed by a blow out preventer (BOP), or
25 the like, provided at the surface of the well. The surface of the well is the top of the uppermost casing of the well.

As the product flows, the temperature sensor modules 120a, 120b, 120c ... 120n of the apparatus 100 are sensing the temperature in the cased well and generating electrical signals that are received and processed by the control module 130 via the electrical network
30 115. The communications module 130 then generates a signal indicative of the temperature at one or more of the temperature sensor modules 120a, 120b, 120c ... 120n which is then processed by the communications module 150 and encoded into acoustic pulses and transmitted along the DST string 210. An acoustic signal receiver 270 located in the DST string at or near the well head 280 detects and decodes the wirelessly transmitted acoustic
35 signal (which may have been conveyed to the well head by a network of relays and

repeaters (not shown)). Data or control signals may be relayed between two or more locations above the annular sealing device wirelessly, by wires and/or by fibre optics. Similarly, data or control signals may be relayed between two or more locations below the annular sealing device wirelessly, by wires and/or by fibre optics.

5 The decoded data signal is then conveyed via an electrical coupling 285 to a rig or ship 290 at the surface where it may be processed further to allow analysis of the sensed temperature data. By analysing the temperature data, detailed information may be obtained indicating the type of fluid flowing in the well, the flow rate and/or the location thereof. If the tubing 110 is arranged along perforating guns 240, the heating effect of the guns as a result
10 of their ignition can be detected, allowing a determination to be made as to whether or not the guns all fired. Before, during, and after perforation the temperature profile of the perforated section can be continuously monitored, and flow from/to the formation assessed. Similarly, if the tubing 110 is arranged around an annular sealing device such as a packer, the heating or cooling effect due to fluid flow from leaks can be detected, allowing an
15 identification to be made as to when sealing elements are and are not effective.

 Instead of the apparatus 100 for use in sensing temperature in a wellbore being provided entirely below and not extending across the annular sealing device 230, in other arrangements, the tubing 110 may extend across the annular sealing device 230 through a bypass port thereof.

20 The apparatus 100 may comprise a memory device, which can store data for retrieval at a later time. The data may be retrieved by a variety of methods. For example it may be transmitted wirelessly at a later time, optionally in response to an instruction to transmit. Or it may be retrieved by a probe run into the well on wireline/coiled tubing or a tractor. The probe can optionally couple with the memory device physically or wirelessly.

25 The apparatus may be configured to store and/or transmit sensor data. The storing of the sensor data may only be for a short period such as up to 1 second or 1 minute, 1 hour or 1 day, for example for the purposes of buffering, or alternatively or in addition, the storing of the sensor data may be for longer periods such as at least a day, at least a month at least a year, at least 2 years, or at least 5 years, for the purposes of long term data storage and
30 subsequent recovery, or partial recovery, wirelessly, by a wired connection or by physical retrieval.

 While Figure 2 illustrates one possible configuration, it is to be understood that the apparatus 100 may be provided downhole to sense a temperature thereof in a number of possible configurations. The apparatus 100 can be deployed in the well on wireline, or
35 coiled tubing, and can be set and/or suspended in the well. As noted above, the tubing 110

of the apparatus 100 for use in sensing temperature in a wellbore can in embodiments extend along and/or around the tubular element 210, which is typically for conveying product to the surface or tooling into and out of the wellbore. Instead of being a drill stem test string, in other embodiments the tubular element can be a drill string, a test string, a completion
5 string, a production string, an injection string, a work-over string, an observation string, a suspension string, an abandonment string, a casing string, a fracturing string, a gravel pack string, a screen or a liner. The apparatus 110 may be used in other well operations, such as during production, work-overs and other interventions, and during well kill operations. Figure 2 illustrates a particularly useful example of a use of the apparatus 100 in which the tubing
10 110 is clamped across a gun, and can be run into the well 201 together with the gun. The apparatus can be deployed with and clamped across a number of different possible downhole tools, and clamping across a gun in a drill stem test operation is only one possible example. After use, the apparatus 100 may be discarded, for example, together with spent guns. On the other hand, the apparatus 100 may instead be retrieved and reused at other
15 locations. In embodiments where no communications unit is provided for wireless transmission of sensed temperature data, the temperature data may instead be logged and stored at the apparatus and recovered later after retrieval of the apparatus from the well.

Arrangements for the construction and operation of the temperature sensor modules 120a, 120b, 120c ... 120n and the control module 130 to sense temperature, address the
20 sensor modules, and to process and recover temperature information in accordance with embodiments will now be described.

One possible arrangement is shown in Figure 3. Here, the apparatus 300 comprises plural temperature sensor modules 320a, 320b, 320c ... 320n connected to a control module 330. Each temperature sensor module comprises a temperature sensor 321 provided at
25 least in part by at least one resistive element having electrical properties that vary with temperature, and a measurement module 322 that takes a signal or measures a temperature-dependent electrical property from the temperature sensor 321, compares it with a temperature-calibrated local reference 323 that is arranged to provide a signal against which variations in the temperature from the measurement from the temperature sensor 321
30 can be revealed by the measurement module 322. The measurement modules 322 thus produce data representative of the temperature measured at each temperature sensor module 320a, 320b, 320c ... 320n and transmit that data to the control module 330 via the electrical network 115. The sensed temperature data can be transmitted to the control module 330 as an analogue signal, where the temperature sensor modules 320a, 320b,
35 320c ... 320n are individually isolatable in the electrical network 115 or by which the analogue signals are multiplexed in the same channel in the electrical network.

Alternatively, the data can be digitally encoded at the temperature sensor modules 320a, 320b, 320c ... 320n and transmitted to the control module 330 using a digital addressing protocol or by multiplexing, where multiple temperature sensor modules 320a, 320b, 320c ... 320n use the same channel in the electrical network. Miniaturisation of the sensor module
5 may be achieved by mounting components on a miniature flexible printed circuit and/or application specific integrated circuits (ASICs) can be used.

At the control module 330, a storage and transmission module 331 is provided to effectively buffer the measured temperature data whereupon it can be passed to the communications module 150 for communication to the surface. An advantage of providing a
10 measurement module and local reference at each temperature sensor module is that data can be readily transmitted to the control module 330 and the electrical network can be relatively simple, requiring only one or two wires to convey the data. For example, a suitable digital addressing system, such as the I²C™, SENT or 1-Wire™ protocols may be used to transmit the data from the temperature sensor modules 320a, 320b, 320c ... 320n to the
15 control module 330 using a small number of wires or even only one wire, which may be the power wire that provides power to the temperature sensor modules 320a, 320b, 320c ... 320n. Each temperature sensor module 320a, 320b, 320c ... 320n may be provided with an analogue to digital converter and an input/output controller (not shown) in order to control the messaging protocol to send the data to the control module 330. Another advantage is
20 that only very short lengths of wire are used to couple the measurement module 322 to the temperature sensor 321 meaning that the resistance of the wire and the temperature variation thereof is negligible, and no compensation for the wire resistance needs to be made.

While the arrangement shown in Figure 3 is advantageous for use in a range of
25 different circumstances, the inter-sensor stability may not be high as required for some, particularly long term, uses as the local references at each temperature sensor module can drift over time. What matters in practical applications where information about the flow of fluid in the wellbore is to be revealed by the apparatus, it is not the monitoring of absolute temperature that is important, but the relative changes in temperature between
30 temperature sensors. Where a degree of inter-sensor drift can occur over time, the relative changes in temperature at the different sensors can be measured less reliably over time of installation. In addition, the provision of the measurement module 322 and local reference 323 (and also a digital input/output controller) at each temperature sensor module 320a, 320b, 320c ... 320n means that the modules 320a, 320b, 320c ... 320n may require
35 significant miniaturisation and sophisticated package design in order to enable them to be small enough to be integrated within the small diameter tubing 110 without having to mount

or weld the temperature sensor modules as larger outer diameter sections in the tubing. Further, the provision of various electronic components within the temperature sensor modules 320a, 320b, 320c ... 320n means that they required increased ruggedisation to ensure that they can reliably withstand significant pressure shockwaves, such as from the
5 ignition of shaped charges from guns 240.

The arrangement shown in Figure 4, however, provides an alternative arrangement for the apparatus that can be of particular use in numerous applications. In the apparatus 400, each temperature sensor module 420a, 420b...420n comprises a temperature sensor 421 provided at least in part by at least one resistive element having electrical properties that
10 vary with temperature,. The local reference and the measurement module at each temperature sensor module of the apparatus 300 is omitted and instead the control module 430 is provided with a measurement module 432 and a common reference 433 that are used to determine a thermal characteristic of each temperature sensor 421 of each temperature sensor module 420a, 420b...420n. In embodiments, the common reference signal generator
15 is a reference voltage source. Here, the use of a reference common to all temperature sensor modules 420a, 420b...420n located at the control module 430 allows the apparatus to provide a relatively high inter-sensor stability as compared to the arrangement shown in Figure 3, with relatively low drift. This provides the apparatus 400 with a high accuracy and reliability of sensed temperature changes along the length of the tubing 110 over time. The
20 provision of a common reference allows the apparatus 400 of this embodiment to be accurate and reliable for the measurement of the relative *changes* between the sensors, which is what is important where information is to be gathered about the flow rate and nature of fluids in the wellbore. In addition, the measurement module 432 and common reference 433 are provided in the control module 430 itself, meaning that the temperature sensor
25 modules 420a, 420b...420n do not need to include these components. Indeed, the temperature sensor modules 420a, 420b...420n may include no other electronic components other than the temperature sensor 421, which may be provided by a single electronic component (and any necessary electrical interconnects and packaging). As a result, the temperature sensor modules 420a, 420b...420n can be very small, which allows
30 the temperature sensor components to be easily integrated into the small diameter tubing 110. Further still, as the relatively sensitive electronic components of the measurement module 432 and common reference 433 are provided in the control module 430 itself, the temperature sensor modules 420a, 420b...420n can easily be made rugged enough to withstand pressure shockwaves due to, for example, the ignition of shaped charges from
35 guns 240. This is particularly the case where appropriately rugged temperature sensors 421 are used and packaged and protected using a potting compound and/or where the tubing

110 is filled with a liquid such as an oil. Further still, the sensor string 410 is relatively simple and cost effective to manufacture, with the temperature sensor modules each being small with very few components and so easy to integrate within the small diameter tubing, and for the control electronics to be provided in a separately assembled control module provided, for example, at an end of or adjacent the tubing.

While Figure 4 shows the common reference signal generator being used as a reference for the measurement of the voltage and/or current of each of the temperature sensor modules, in embodiments, the common reference generator may be used as a reference for the measurement in relation to fewer than all but at least two of the temperature sensors.

In Figure 4, the measurement module 432 is located in the control module 430, remote from the temperature sensor modules 420a, 420b...420n. The measurement module 432 is preferably configured to measure an analogue electrical characteristic of the temperature sensors 421 at a distance, by addressing or connecting exclusively to a temperature sensor 421 of a specific temperature sensor module 420a, 420b...420n through the electrical network 115, or otherwise discerning the electrical characteristic of a particular temperature sensor 421 in a measured analogue signal. This may be achieved by providing the electrical network 115 configured so as to allow the receiving and processing of an separate analogue signal from the different temperature sensors 421 at the control module 430. Examples of suitable electrical network configurations are described below with reference to Figures 7, 8 and 9. Alternatively, in order to convey the electrical signal indicative of the temperature sensed by the temperature sensors 421 to the control module 430 for receipt and processing by the measurement module 432, a digital addressing system could again be used whereby each temperature sensor module 420a, 420b...420n is provided with a digital encoder module (not shown) whereby a signal based on the common reference is passed to the temperature sensor modules and an electrical signal sensed by the temperature sensor 421 is digitised and conveyed as digitally encoded data to the control module using an appropriate digital communication protocol.

Alternatively, a hybrid of Figures 3 and 4 may be used (not shown), where a common reference at the control module is supplied to each temperature sensor module, and a measurement module provided at each temperature sensor module. A digital signal representative of temperature can be used to communicate the measurement to the control module.

Indeed, Figures 5 and 6 show arrangements for digitally connecting the temperature sensor modules to the control module, whereas Figures 7, 8 and 9 show methods of

addressing the temperature sensors and receiving and processing analogue signals therefrom at the control module.

In the Figure 5 arrangement, a series of temperature sensor modules 520a, 520b, 520c ... 520n are connected by connecting them in parallel between two power supply rails providing voltages V+, V- from the control module 530. The temperature sensor modules 520a, 520b, 520c ... 520n are provided with digital encoders configured to transmit signals indicative of the measurement by the temperature sensor (whether that is a temperature measurement, or an electrical signal as-yet unprocessed indicative of a measured thermal characteristic) to the control module 530 by modulating the signal on one or both of the power rails, in accordance with a suitable digital communication protocol.

One possible elegant implementation of the arrangement shown in Figure 5 to allow digital communication with the temperature sensor modules would be to couple the temperature sensor modules inside the length of the tubing 110 using a wire, and to couple each of the temperature sensor modules to the body of the tubing itself to use the tubing body as the return path for the signal.

In the Figure 6 arrangement, a series of temperature sensor modules 620a, 620b, 620c ... 620n are connected by connecting them in parallel between two power supply rails providing voltages V+, V- from the control module 630. The temperature sensor modules 620a, 620b, 620c ... 620n are provided with digital encoders configured to transmit signals indicative of the measurement by the temperature sensor (whether that is a temperature measurement, or an electrical signal as-yet unprocessed to indicative of a measured thermal characteristic) to the control module 630 by modulating the signal on a common (third) wire, in accordance with a suitable communication protocol.

Alternatively, in the arrangement shown in Figure 6, the temperature sensor modules 620a, 620b, 620c ... 620n can be addressed digitally by the control module 630, using a suitable digital communication channel over the two power supply rails, and the temperature sensor modules 620a, 620b, 620c ... 620n may be configured to provide an analogue signal to the control module 630 in response using the third wire.

In accordance with the digital communication arrangements illustrated in Figures 5 and 6, a large number of temperature sensor modules (limited by the addressing capacity of the protocol used) can be connected them in parallel into the electrical network requiring only a small number of wires. This allows the length of the tubing 110 over which the temperature sensitive array can be spread to be long and/or the spatial resolution that can be achieved by narrowly spacing the temperature sensor modules to be high. These arrangements allow the number of temperature sensor modules to be provided in the tubing

to be very high, for example greater than ninety, which would be more difficult to achieve using the matrix addressing arrangement described below in relation to Figures 8 and 9.

While digital integrated circuit temperature sensors could be used in the temperature sensor modules 320a, 320b, 320c ... 320n to provide the temperature sensor 321, these
5 generally have a temperature resolution, accuracy and stability that is too low for the desired wellbore sensing applications.

Where analogue signals are to be transmitted to the control module, separate wires can be used. Thus, in the Figure 7 arrangement, a series of temperature sensor modules 720a, 720b, 720c ... 720n are connected between two power supply rails providing voltages
10 V+, V- from the control module 730. The temperature sensor modules 720a, 720b, 720c ... 720n, in response to the applied voltage V+, V-, provide on separate wires 725a, 725b, 725c ... 725n signals indicative of the measurement by the temperature sensor (whether that is a temperature measurement, or an electrical signal as-yet unprocessed to indicative of a measured thermal characteristic) that is received and processed at the control module 730
15 via the separate wires 725a, 725b, 725c ... 725n. The control module 730 may process the received electrical signals to determine a temperature measure.

In the arrangement shown in Figure 7, for each additional sensor that is added to the array, an additional wire is required. In a normal 19 core wire bundle that can be fitted into small diameter tubing, this would limit the number of sensors that could be provided.
20 However, the arrangement shown in Figure 7 could be combined with the arrangement shown in Figure 6 whereby multiple, digitally addressed, temperature sensor modules are provided common to each return wire.

To achieve a high number of sensors in the array without using a digital communication protocol, when the number of wires in the tubing 110 is limited, in
25 embodiments the wires and temperature sensor modules can be arranged in the electrical network as a "matrix" as shown schematically in Figure 8. In this arrangement 800, the tubing 110 containing the electrical network 115 comprises plural wires that connect the plural resistive temperature sensors modules 820. The wires are configured to provide the electrical network 115 arranged as a matrix by which the wires comprise a first group of
30 wires 815a and a second, different group of wires 815b and each wire of the first group 815a is electrically connected to each wire of the second group 815b once, by different temperature sensor modules 820, such that each module 820 can be individually electrically connected by a pair of wires comprising a first wire from the first group 815a and a second wire from the second group 815b.

In this way, a significantly greater number of temperature sensors can be operated in an analogue addressing regime using the same number of wires. For example, for a standard 19 core wire bundle, the Figure 7 arrangement could be used to provide only up to 17 temperature sensors. The use of a matrix allows a number greater than this to be provided, and for a 19 core wire bundle, grouped into a group of 10 and a group of 9 wires, up to 90 temperature sensor modules 820 can be provided, as shown in Figure 8. These can be individually addressed by connecting them to the control module (not shown) by provision of switches, which may be operated by a relay or relays 823, and which can switch through combinations of pairs of wires to electrically connect and infer a temperature at each of the temperature sensor modules 820. For example, a particular temperature sensor module 820ij can be connected by switching the relay to connect the i th wire 815ai from the first wire group and the j th wire 815bj from the second wire group, where all of the other wires may be disconnected. The relay 823 can periodically switch through combinations of pairs of wires to electrically connect and infer a temperature at each of the temperature sensor modules.

To prevent unwanted reverse current flow and current leakage through the electrical network, each temperature sensor module 820 includes, or is connected in series with a blocking diode 826. Thus the diodes 826 are low reverse current leakage diodes, having a reverse current leakage of less than 50 nA at the operational voltage of the apparatus 800 and at a temperature of 25 degrees Celsius. The temperature sensitivity of each of the temperature sensor modules 820 is provided at least in part by a resistive component, which may be an integrated circuit temperature sensor or a second diode provided in addition to the blocking diode. Alternatively, instead of providing a blocking diode 826, the blocking effect may be provided by another component such as a FET, and the blocking component and the resistive component providing temperature sensitivity of the temperature sensor modules may be combined together or integrated into an IC.

Where appropriate, the voltage drop due to the resistivity of the wires and the temperature sensitivity thereof can be compensated for by calibration means configured to compensate for the resistance of wires in the lines that connect the resistive elements of the temperature sensors to the measurement module (provided in the control module), and also for the temperature dependence of the resistivity of those wires. The calibration means is provided as part of the control module. The calibration means compensates for the wire resistance by determining the resistance characteristics of the wires or the individual circuits associated with each temperature sensor of the apparatus. This wire resistance characterisation can be performed first in a controlled test environment prior to deployment. The calibration means then compensates for that wire/circuit resistance to isolate the

responsiveness of the electrical properties of the temperature sensors to temperature variations. Specifically, in embodiments, the calibration means is configured to achieve this resistance compensation by having, prior to use, measured the resistance of the wiring to each sensor at least 2 known temperatures to determine the resistance and temperature coefficient of the individual sensor wiring. These resistance and temperature coefficients of the individual sensor wiring are stored as calibration data in the calibration means. In use, the calibration means is configured to use the prior calibration data and the known temperature of segments of the wire to calculate the resistance of the wiring to a sensor at a point in time.

10 In each of the arrangements shown in Figures 3 to 8, the temperature sensitivity of the temperature sensor modules is provided at least in part or solely by at least one resistive element having electrical properties that vary with temperature, such as a one or more thin-film platinum resistance sensors or an integrated circuit with a built in resistive temperature sensor. These can provide one or more of the advantages of robustness, small size, ability to integrate within the profile of small diameter tubing to facilitate installation of the apparatus, simplicity and cost effectiveness to manufacture, ability to provide a large number of sensor modules in a single tubing, and sufficiently stable, accurate and low drift temperature measurements useful for a range of applications.

20 A method 1100 of operation of apparatus described above in relation to Figures 1- 8 to determine a temperature along a wellbore will now be described with reference to Figure 9.

25 Firstly, in step 1101 the temperature sensors in the tubing is actively heated by applying a current through a resistor arranged adjacent the temperature sensor or by using the resistance associated with the temperature sensor module itself, or by self-heating the sensors by applying a current through them. For example, a high current load could be applied to resistive temperature sensors to heat them. Alternatively, the temperature sensors could be actively cooled, for example, by use of one or more peltier devices, or cooling lines and a heat exchanger.

30 Then, in step 1102, a change of temperature of the or each sensor is monitored during and/or after heating.

35 Then, to translate a measured temperature in 1102 into information on the fluid (such as flow rate, an indication of the type of fluid components, etc), in step 1103, a fluid flow characteristic of the environment to which the tubing is exposed at the locations of the temperature sensors is inferred based on the change of temperature, or on a rate of change of temperature, or the power to create a change in temperature of the sensors during and/or

after heating. An indication of the type of fluid components (e.g. gas/oil/water) to which the apparatus 100 is exposed is achievable as the specific heat capacity, thermal conductivity and density of the different fluids lead to differing thermal response when the sensors are heated.

5

Claims

1. Apparatus for use in a wellbore, for use in sensing temperature in a wellbore, the apparatus comprising:
 - 5 a metallic tubing comprising at least 6 temperature sensor modules provided at locations along the inside of the metallic tubing, the temperature sensor modules comprising temperature sensors provided at least in part by a resistive element whose electrical resistance is dependent on temperature;
 - 10 an electrical network configured to electrically connect to the resistive elements to allow measuring of the respective electrical properties of the resistive elements to infer a thermal characteristic of the resistive element; and
 - 15 at least one downhole control module electrically connected to multiple of said temperature sensor modules, via the electrical network, and configured to receive and process an electrical signal associated with the temperature sensor modules to enable inference of the temperature of the resistive elements and an environment to which the metallic tubing is exposed at the location of that resistive element, and
 - 20 wherein the metallic tubing outer diameter is in the range of 3 mm to 14 mm at the location in the metallic tubing of at least one of the temperature sensor modules, and wherein the at least one downhole control module further comprises a common reference signal generator used as a reference for a measurement of the voltage and/or current of at least two temperature sensor modules.
2. Apparatus as claimed in claim 1, wherein the metallic tubing is one of a stainless steel, a duplex or super-duplex stainless steel, a nickel alloy, titanium or a titanium alloy.
- 25 3. Apparatus as claimed in any one of claims 1 to 2, wherein the metallic tubing outer diameter is in the range of 6 mm to 10 mm.
- 30 4. Apparatus as claimed in any one of claims 1 to 3, wherein the outer diameter of the metallic tubing is the same at locations in the metallic tubing of at least one of the temperature sensor modules and at locations in the metallic tubing away from the at least one of the temperature sensor modules.
5. Apparatus as claimed in any one of claims 1 to 4, wherein the resistive element is one of a platinum and nickel based resistance temperature device (RTD).

6. Apparatus as claimed in claim 5, wherein the RTD is constructed of one of a wire coil, a wound wire, and a thin-film deposited on a ceramic substrate.
- 5 7. Apparatus as claimed in any one of claims 1 to 4, wherein the resistive element is a thermistor.
8. Apparatus as claimed in any one of claims 1 to 7, wherein the metallic tubing is filled with and encapsulates a non-conducting liquid to protect the temperature sensor modules from pressure shockwaves created by perforating guns.
- 10 9. Apparatus as claimed in claim 8 wherein the metallic tubing comprises a pressure balancer, including at least one of a bellows and a flexible bladder, configured to act to equalise internal pressure in the tubing with the ambient environment.
- 15 10. Apparatus as claimed in any one of claims 1 to 9, wherein the temperature sensor modules in the metallic tubing are encased in a potting compound.
11. Apparatus as claimed in any one of claims 1 to 10, wherein the metallic tubing comprises plural wires; and wherein the wires and plural temperature sensors are configured such that the electrical network is arranged as a matrix by which the wires comprise a first group of wires and a second, different group of wires and each wire of the first group is electrically connected to each wire of the second group once, by different temperature sensor modules, such that each module can be individually electrically connected by a pair of wires comprising a first wire from the first group and a second wire from the second group.
- 20 25 12. Apparatus as claimed in any one of claims 1 to 11, further comprising a calibrator configured to compensate for the resistance of wires in the line that connect the resistive elements of the temperature sensors to the downhole control module, and for the temperature dependence of the resistivity of those wires, and wherein the calibrator is provided as part of the downhole control module.
- 30 13. Apparatus as claimed in any one of claims 1 to 12, wherein the common reference signal generator is a reference voltage source.
- 35 14. Apparatus as claimed in any one of claims 1 to 13, wherein multiple control modules are provided, wherein individual control modules control sets of temperature sensor

modules, and the control modules are linked to at least one master control module(s).

- 5 15. Apparatus as claimed in any one of claims 1 to 14, wherein the metallic tubing containing the temperature sensor modules is arranged as at least one of a ring and a helix to extend around a tubular element of a well apparatus.
- 10 16. Apparatus as claimed in any one of claims 1 to 15, further comprising a power source configured to provide operational power to the apparatus for sensing temperature in the wellbore in use, wherein the power source is arranged to be provided as an in-well power source in use, wherein the power source is replaceable in the well.
- 15 17. Apparatus as claimed in claim 16, wherein the power source comprises at least one primary cell(s), secondary cell(s) and downhole power generator(s).
18. Apparatus as claimed in any of claims 1 to 15, wherein the apparatus is configured to be powered in use from a position higher in the well, via at least one of inductive and capacitive coupling.
- 20 19. Apparatus as claimed in any one of claims 1 to 18, further comprising a wireless data communication module coupled, wirelessly, by a separate wireless connection, to the apparatus for use in sensing temperature in the wellbore and arranged to, in use:
wirelessly transmit along the well signals indicative of a temperature sensed in the wellbore by the apparatus, and wherein the wireless data communication module is
25 configured to transmit said signals at least one of acoustically and electromagnetically.
- 30 20. Apparatus as claimed in any one of claims 1 to 19, wherein the temperature sensor module comprises an electronic circuit configured to vary at least one of a current, a voltage, and a frequency with a temperature of the sensor.
- 35 21. Apparatus as claimed in any one of claims 1 to 20, wherein the apparatus is configured such that, in use, at least one temperature sensor module is selected by the downhole control module digitally addressing the temperature sensor module, and wherein the selected temperature sensor module enables a voltage, current or

frequency output representative of the temperature of a resistive element to be connected to the downhole control module.

5 22. Apparatus as claimed in any one of claims 1 to 21, wherein at least one temperature sensor module comprises a single integrated electronic component incorporating the resistive element.

10 23. Apparatus as claimed in claim 22, wherein the maximum physical extent of the single integrated electronic component in any axis is less than 7mm.

15 24. Apparatus as claimed in any one of claims 1 to 23, wherein the downhole control module is configured to measure an analogue current, voltage and/or frequency associated with the temperature sensor modules to enable inference of the temperature of the resistive elements and the environment to which the metallic tubing is exposed at the location of that resistive element.

20 25. Apparatus as claimed in any one of claims 1 to 24, further comprising a wireless data communication module coupled, wirelessly, by a separate wireless connection, to the apparatus for use in sensing temperature in the wellbore and arranged to, in use: wirelessly receive control signals for controlling the operation of the apparatus, and wherein the wireless data communication module is configured to transmit said signals at least one of acoustically and electromagnetically.

25 26. Apparatus as claimed in any one of claims 1 to 25 wherein the downhole control module is disposed downhole in relation to the wellbore.

30 27. A well comprising a well apparatus having a temperature sensing apparatus comprising: a metallic tubing, comprising at least 6 temperature sensor modules provided at locations along the inside of the metallic tubing, the temperature sensor modules comprising temperature sensors provided at least in part by a resistive element whose electrical resistance is dependent on temperature;

an electrical network configured to electrically connect to the resistive elements to allow measuring of the respective electrical properties of the resistive elements to infer a thermal characteristic of the resistive element; and

at least one downhole control module electrically connected to multiple of said temperature sensor modules, via the electrical network, and configured to receive and process an electrical signal associated with the temperature sensor modules to enable inference of the temperature of the resistive elements and an environment to which the tubing is exposed at the location of that resistive element, and

wherein the tubing outer diameter is in the range of 3 mm to 14 mm at the location in the tubing of at least one of the temperature sensor modules, and wherein the at least one downhole control module further comprises a common reference signal generator used as a reference for a measurement of the voltage and/or current of at least two temperature sensor modules, and wherein the temperature sensing apparatus is arranged to sense a temperature in a wellbore of the well.

28. A well as claimed in claim 27, wherein the well apparatus comprises an annular sealing device provided at least 100m below a surface of the well, and between a wellbore or a casing of the wellbore and a tubular.

29. A well as claimed in claim 28, wherein the temperature sensing apparatus for use in sensing temperature in the wellbore is provided entirely below the annular sealing device.

30. A well as claimed in claim 28, wherein the metallic tubing of the temperature sensing apparatus for use in sensing temperature in the wellbore does not extend across the annular sealing device.

31. A well as claimed in any of claims 27 to 30, wherein the well apparatus comprises a tubular element and wherein the metallic tubing of the temperature sensing apparatus for use in sensing temperature in a wellbore extends along and/or around the tubular element.

32. A well as claimed in 31, wherein the tubular element is a drill string, and wherein the drill string comprises a drill bit or mill.

33. A well as claimed in any of claims 31 to 32, wherein the metallic tubing is clamped to the tubular element in the well.

34. A well as claimed in any of claims 27 to 31, wherein the temperature sensing apparatus is deployed in the well on wireline, or coiled tubing, and set and/or suspended in the well.
- 5 35. A well as claimed in any of claims 27 to 30, wherein the temperature sensing apparatus is configured to monitor the temperature at a barrier in the well.
36. A well as claimed in any of claims 27 to 35, wherein the well is a production and/or injection well.
- 10 37. A well as claimed in any of claims 27 to 36, where the well is in a suspended or abandoned phase, and the temperature sensing apparatus is configured to monitor the well.
- 15 38. A method of calibrating apparatus as claimed in any one of claims 1 to 26, wherein each of the temperature sensors of the apparatus comprises an individual circuit associated therewith, the method comprising: determining resistance characteristics of the individual circuits, and compensating for that circuit resistance to isolate responsiveness of the electrical properties of the temperature sensors of the apparatus to temperature variations.
- 20 39. A method of operation of apparatus as claimed in any of claims 1 to 26 to determine a thermal characteristic of at least one of the temperature sensors thereof, comprising:
- 25 actively heating and/or cooling the at least one of the temperature sensors in the metallic tubing; and
- monitoring a change of temperature of the at least one of the temperature sensors during and/or after heating and/or cooling.
- 30 40. A method as claimed in claim 39, further comprising, based on the change of temperature, or on a rate of change of temperature, or the power to create a change in temperature of the sensors during and/or after heating or cooling, inferring a fluid characteristic of the environment to which the tubing is exposed at the locations of the temperature sensors.

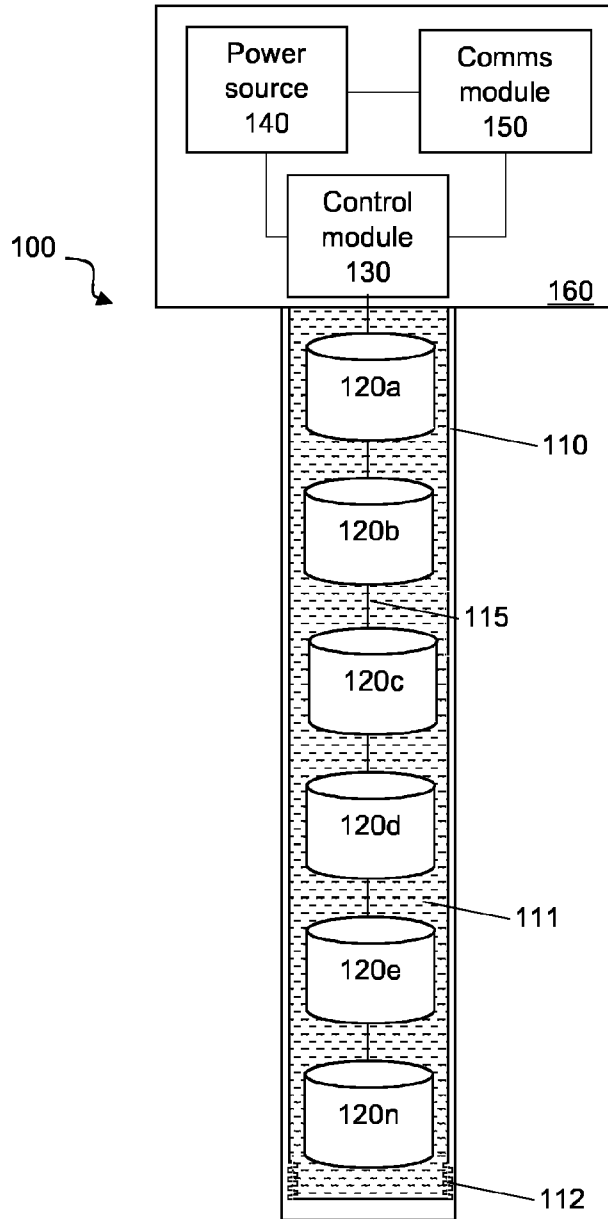

Figure 1

2/6

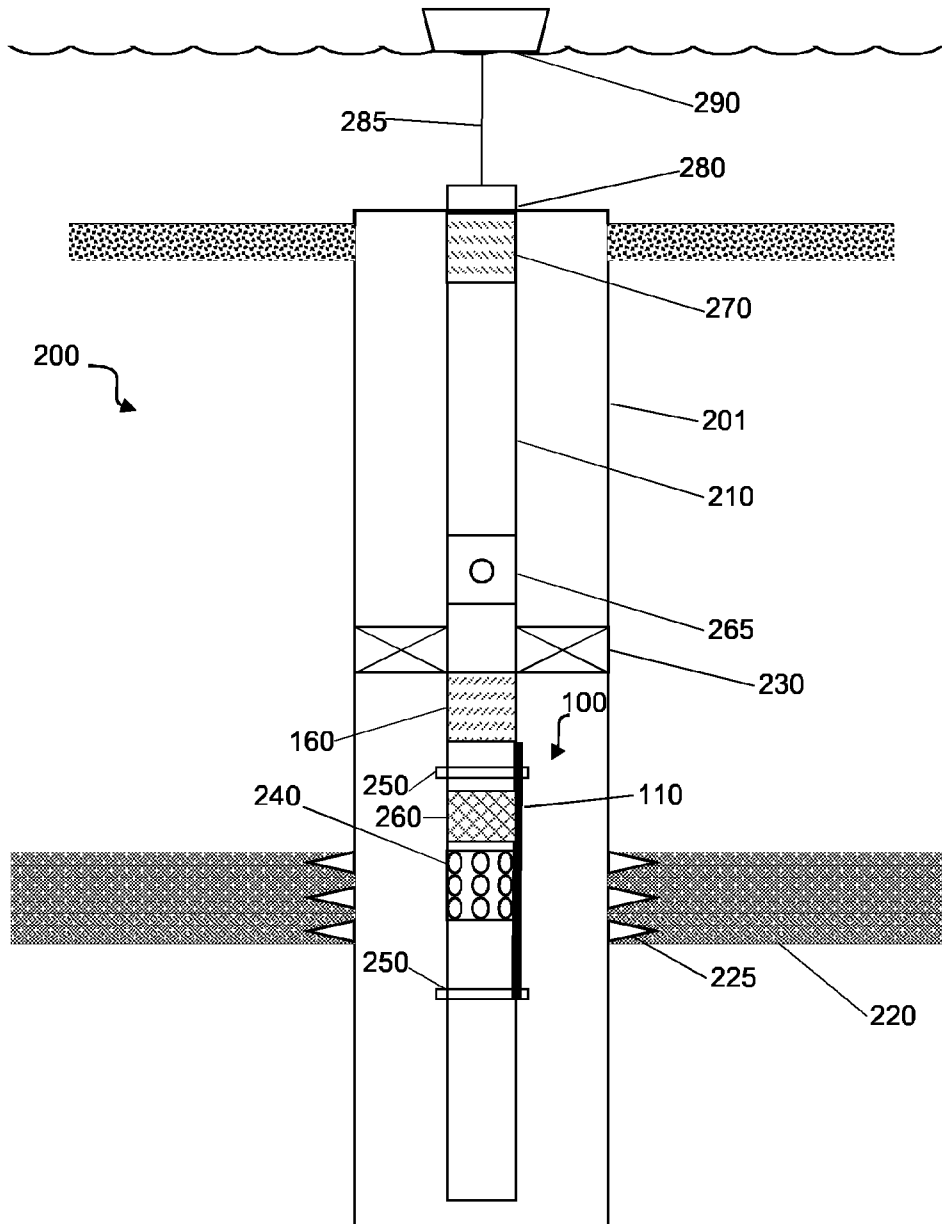

Figure 2

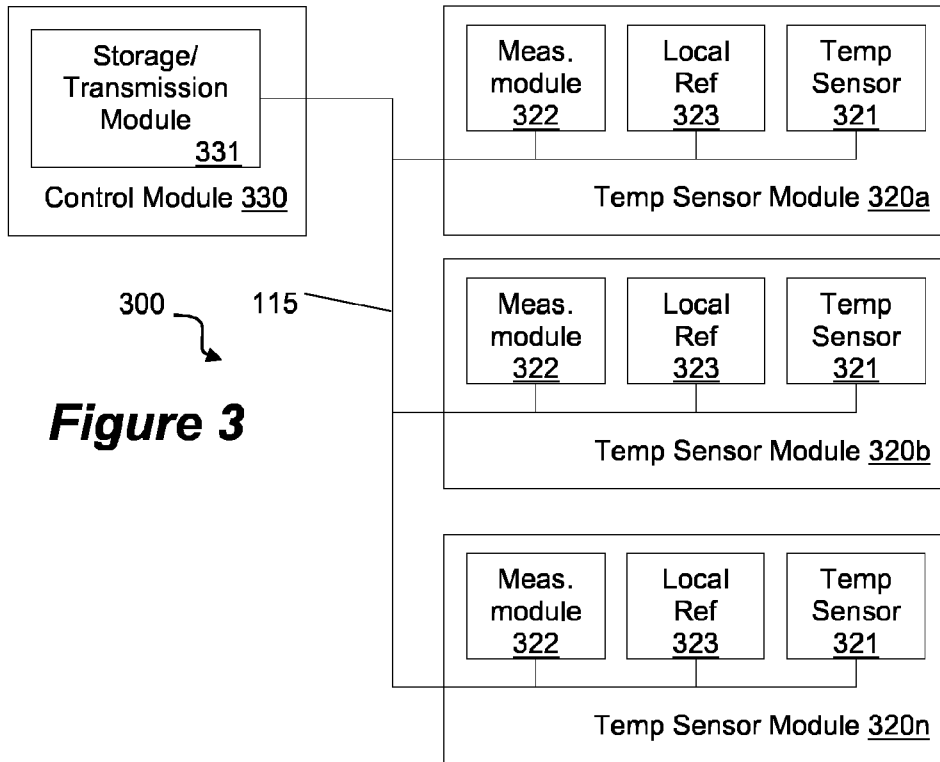

Figure 3

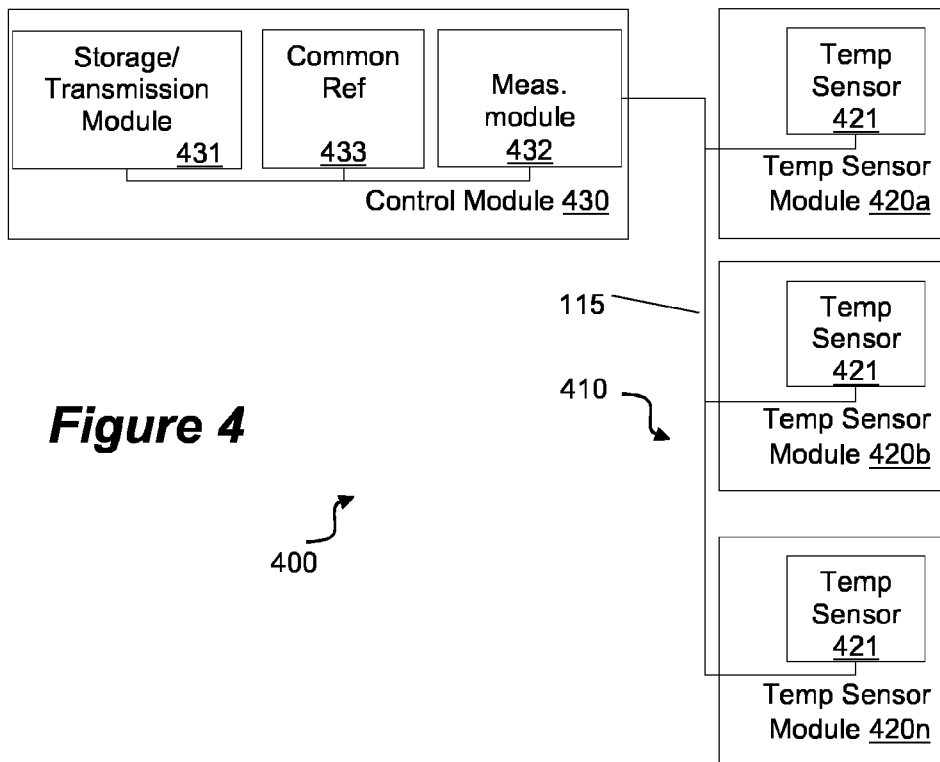

Figure 4

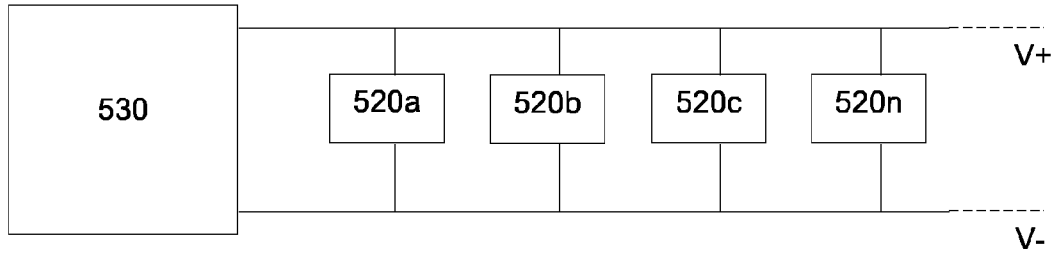

Figure 5

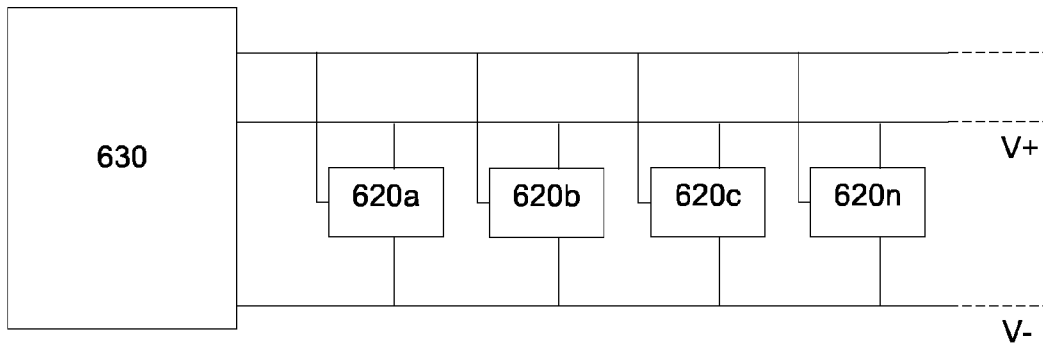

Figure 6

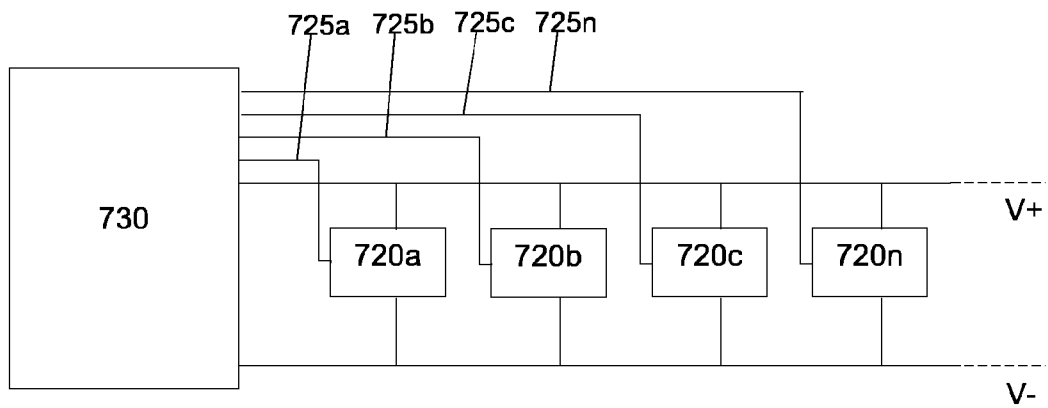

Figure 7

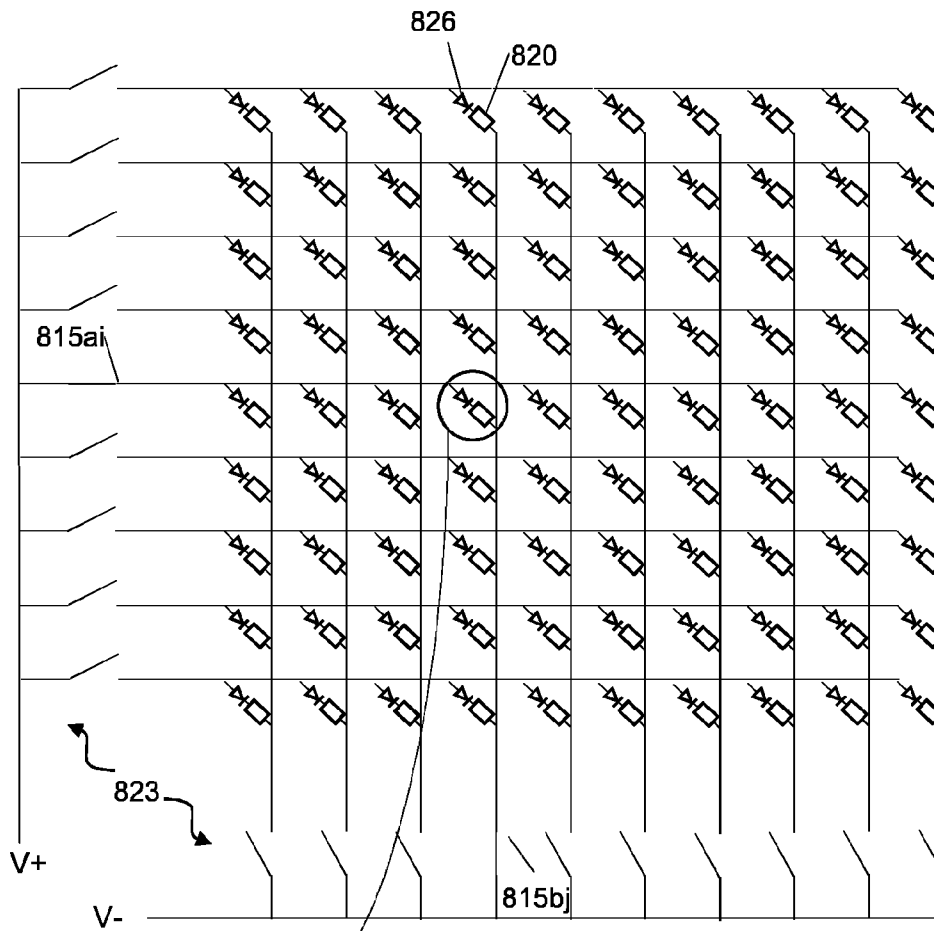
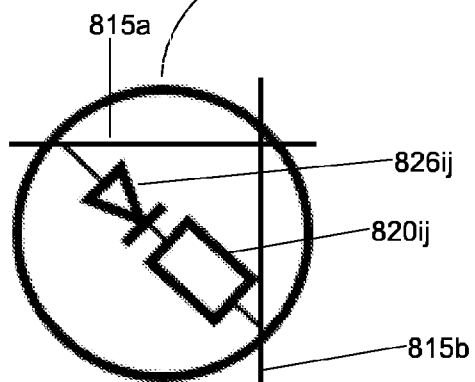
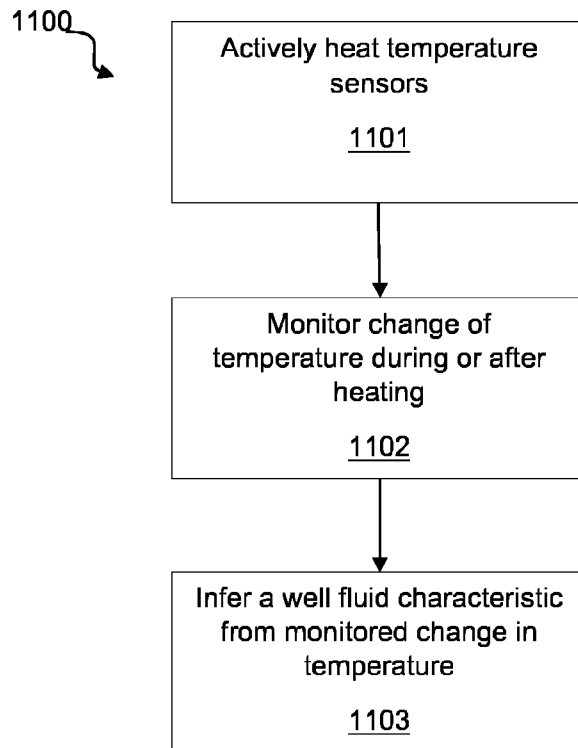

Figure 8



6/6

**Figure 9**

1100



**Actively heat temperature
sensors**
1101

**Monitor change of
temperature during or after
heating**
1102

**Infer a well fluid characteristic
from monitored change in
temperature**
1103