



- (51) **International Patent Classification:**  
*F25D 17/04* (2006.01) *F25D 25/02* (2006.01)
- (21) **International Application Number:**  
PCT/EP2014/065213
- (22) **International Filing Date:**  
16 July 2014 (16.07.2014)
- (25) **Filing Language:** English
- (26) **Publication Language:** English
- (30) **Priority Data:**  
2013/09044 25 July 2013 (25.07.2013) TR
- (71) **Applicant:** BSH BOSCH UND SIEMENS HAUSGERÄTE GMBH [DE/DE]; Carl-Wery-Str. 34, 81739 München (DE).
- (72) **Inventors:** DEMİRÖZ, Taha; Esentepe Mah. Adnan Dogu Cad. Ergene Vadisi B1/41 Corlu, 59850 Tekirdag (TR). ERTIK, Mustafa; Muhittin Mah. Armada City Konutlari A3-16 Corlu, 59850 Tekirdag (TR). TEKTAS, Salih; Resadiye Mah. S.Kursun Cad. 5.Sok.Özgün Apt. No:2/4 Corlu, 59850 Tekirdag (TR). INCEREIS, Onur;

Suadiye Mah. Kaptan Arif Sok. No:56/16 Kadikoy, 34520 Istanbul (TR).

(81) **Designated States** (unless otherwise indicated, for every kind of national protection available): AE, AG, AL, AM, AO, AT, AU, AZ, BA, BB, BG, BH, BN, BR, BW, BY, BZ, CA, CH, CL, CN, CO, CR, CU, CZ, DE, DK, DM, DO, DZ, EC, EE, EG, ES, FI, GB, GD, GE, GH, GM, GT, HN, HR, HU, ID, IL, IN, IR, IS, JP, KE, KG, KN, KP, KR, KZ, LA, LC, LK, LR, LS, LT, LU, LY, MA, MD, ME, MG, MK, MN, MW, MX, MY, MZ, NA, NG, NI, NO, NZ, OM, PA, PE, PG, PH, PL, PT, QA, RO, RS, RU, RW, SA, SC, SD, SE, SG, SK, SL, SM, ST, SV, SY, TH, TJ, TM, TN, TR, TT, TZ, UA, UG, US, UZ, VC, VN, ZA, ZM, ZW.

(84) **Designated States** (unless otherwise indicated, for every kind of regional protection available): ARIPO (BW, GH, GM, KE, LR, LS, MW, MZ, NA, RW, SD, SL, SZ, TZ, UG, ZM, ZW), Eurasian (AM, AZ, BY, KG, KZ, RU, TJ, TM), European (AL, AT, BE, BG, CH, CY, CZ, DE, DK, EE, ES, FI, FR, GB, GR, HR, HU, IE, IS, IT, LT, LU, LV, MC, MK, MT, NL, NO, PL, PT, RO, RS, SE, SI, SK, SM,

[Continued on next page]

(54) **Title:** A HOME APPLIANCE HAVING A CONTAINER WITH ADJUSTABLE HUMIDITY

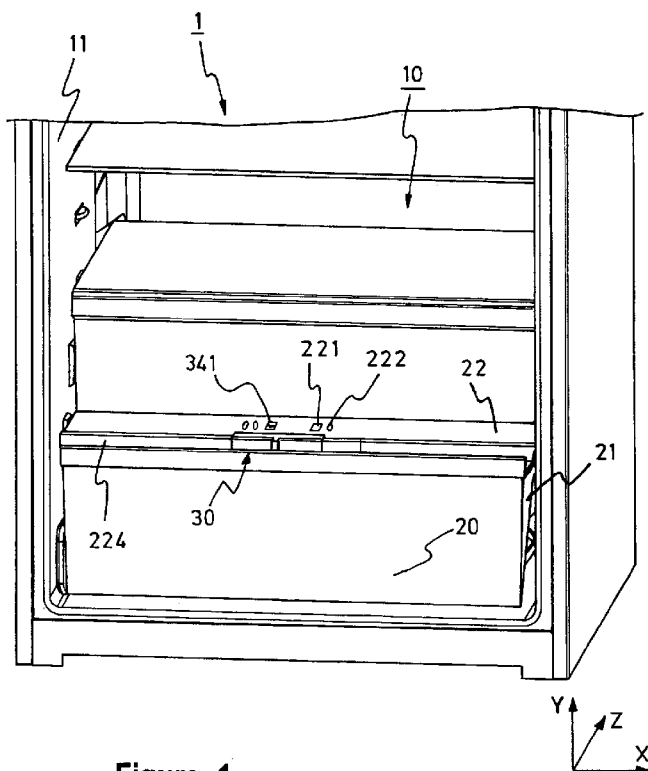

Figure- 1

(57) **Abstract:** The invention is a home appliance (1), particularly a refrigerator, comprising a container (20); and an adjuster (30) adjusting humidity inside the container (20); and also comprising a display section (221) being related to a pre-determined humidity setting and at least partially transparent and provided in vicinity of adjuster (30); and an indicator element (34) making a sign (341), proving that the pre-determined humidity setting is set, visible through the display section (221) by moving with the adjuster (30).

TR), OAPI (BF, BJ, CF, CG, CI, CM, GA, GN, GQ, GW, KM, ML, MR, NE, SN, TD, TG). **Published:**

— with international search report (Art. 21(3))

## SPECIFICATION

### A HOME APPLIANCE HAVING A CONTAINER WITH ADJUSTABLE HUMIDITY

#### 5 **Technical Field**

The present invention relates to a home appliance having a container with adjustable humidity. The present invention particularly relates to a refrigerator having a container wherein fresh food such as fruits and vegetables are disposed.

#### 10 **Prior Art**

Home appliances, particularly cooling devices like domestic refrigerators have a container wherein fresh food is stored. The fresh food can be milk or meat product, and it is generally fruit or vegetable. Particularly fruits and vegetables continue to ripen after they are harvested. In order to retard spoiling of fruits and vegetables, they should be in a suitable  
15 condition. One of the required conditions is the humidity setting.

In the containers provided in said refrigerators and called crisper, pluralities of mechanisms and methods are provided for providing suitable humidity setting.

20 The most frequently used one among these is to use an opening providing air exchange between the inner side of the container and the outer side of the container and to use a cover determining the opening amount of said opening. Said cover is generally manually controlled by the user, and it is completely or partially opened or closed.

25 Another mechanism is described in the international patent application WO2011026749. Accordingly, there is a container in a cooling device. The container comprises a drawer and a cover which can be height-adjusted between a closed position and an open position. For the vertical adjustment of the cover, a slide is used which is movable horizontally. The slide and the cover are connected to each other through a guide. The slide is preferably connected to  
30 a front edge of a horizontal wall.

The present invention provides an additional improvement, an additional advantage or an alternative to the abovementioned present art.

**Object of the Invention**

The main object of the present invention is to provide a home appliance having a container allowing the user to notice visually which humidity setting is being adjusted.

5 In order to realize said object, the present invention is a home appliance comprising a container; and an adjuster adjusting humidity inside the container; and a display section being related to a pre-determined humidity setting and at least partially transparent and provided in vicinity of adjuster; and an indicator element making a sign, proving that the pre-determined humidity setting is set, visible through the display section by moving with the  
10 adjuster. Thus, when the user moves the adjuster, the user notices a sign in the display section of the humidity setting desired to be set, and understands that the desired setting is done.

In a possible embodiment of the present invention, said home appliance may be a cooling  
15 device, particularly a refrigerator. The home appliance may have a housing defined by an inner liner. The housing may comprise the container. The walls of the home appliance may be heat insulated.

The container of the home appliance may be any container keeping a member therein which  
20 has to be kept in a condition whose humidity setting is controlled. The container may be a container wherein food, for instance like fruit, vegetable and/or meat and milk products which may be spoiled are positioned. For instance, the container may be a crisper drawer. The container may be closed, when desired, in a manner preventing humidity leakage.

25 The adjuster may function manually, mechanically and/or electronically. The adjuster may be made of plastic material, metal or a different material known to be used in the present art. The adjuster and the indicator element may be connected in an integrated manner or in a separated manner. For instance, the adjuster and the indicator element may be molded so as to provide an integrated structure made of plastic material.

30

As a sign, only one color or one figure or both of them may be used.

The display section may be partially or completely transparent. It is sufficient for the display section to be transparent in a ratio that the sign is distinguishable by the user. There may be

one or more than one display sections. For instance, there may be three display sections describing the lower and upper limits and the intermediate adjustment of the humidity setting.

5 In a possible embodiment of the present invention, the container may comprise a cover moveable between a first position not allowing any leakage of humidity from the container or allowing leakage in some amount and a second position allowing leakage of humidity from the container more than the first position by the movement of the adjuster. Thus, an opening, allowing air exchange between the container and the outer environment, may be controlled. The closing proportion of the opening may determine the humidity setting.

10

In a possible embodiment of the present invention, the adjuster may comprise a transfer element connected to the cover for transferring the movement of the adjuster. Thus, the adjuster may be provided at a different position from the cover. By means of the transfer element, work efficiency and power saving may be provided as a result of applying relatively less work to the cover than the work should be applied directly to the cover. The adjuster may become suitable to an optional design, since the direction and amount of the force to be applied to the cover is changed by means of the transfer element.

15

In a possible embodiment of the present invention, the adjuster may comprise a body configured as linearly slidable. Thus, the adjuster may be positioned at an edge of a home appliance, a container or another suitable member, and may realize sliding movement on the edge. For instance, it may be positioned on the upper edge of the front wall of the container. Since the adjuster is positioned on an edge which does not present an active volume during the usage of the home appliance, volume saving may be provided inside the home appliance.

25

In a possible embodiment of the present invention, the home appliance may comprise two display sections, one for the highest possible humidity setting and one for the lowest possible humidity setting. Thus, the user may be informed in a clear manner, and the perception level of the user may be kept high. As a result, the humidity setting may be realized in a correct manner.

30

In a possible embodiment of the present invention, two display sections may be configured to be on a line parallel to a line on that the adjuster slides. Thus, in addition to the advantages

of the body which may realize sliding process, the indicator element, having the simplest possible design, may be used. For instance, the indicator element may be a plate connected to the adjuster. By means of this, the production costs may be kept at a low level.

- 5 In a possible embodiment of the present invention, the indicator element may comprise a different sign for each of the display sections. Thus, the user may be informed in a clear manner and the perception level of the user may be kept at a high level. As a result, the humidity setting may be realized in a correct manner.
- 10 In a possible embodiment of the present invention, a wall of the container may comprise the display section. For instance, the wall of the container may be an upper wall of the container. Thus, it may be guaranteed that the display section is visible by the user. By means of this, the perception level of the user may be kept at a high level. As a result, the humidity setting may be realized in a correct manner. Moreover, since external regions and external items are
- 15 not used, production costs like material cost and labor cost may be kept low.

The upper wall may be an external element of the container. The upper wall may be a plate, for instance a shelf positioned on the container. The adjuster may be positioned on an edge of the upper wall. For instance, it may be positioned on the front wall of the upper wall.

- 20 In a possible embodiment of the present invention, the home appliance may comprise an information element provided in vicinity of the display section and indicating that the humidity setting related to the display section is suitable for which fresh meal. Thus, the user may be informed in a clear manner, and the perception level of the user may be kept at a high level.
- 25 As a result, the humidity setting may be realized in a correct manner.

### **Brief Description of the Figures**

In Figure 1, the frontal partial view of a possible refrigerator is given. The door of the refrigerator is not illustrated.

- 30 In Figure 2, the perspective view of a possible container upper wall, of a cover and of an adjuster is given. Since the upper wall is transparent, the partial view of the cover and of the indicator element is given with the lines having a paler color.

In Figure 3, the upper perspective view of a possible adjuster and of an indicator element is given.

In Figure 4, the bottom perspective view of a possible adjuster and of an indicator element is given.

In Figure 5, the upper view of a possible display section and of an information element is given.

5 In Figure 6, the top view of a possible adjuster and of an indicator element is given.

### Detailed Description of the Invention

The direction statements like front, upper, lower are described by taking the part, when the home appliance (1) presented in Figure-1 is viewed in direction z, as reference of "front".

10 Below, one or more than one of the possible embodiments of the present invention are described in a detailed manner.

The present invention relates to a home appliance (1) comprising a container (20); and an adjuster (30) providing adjustment of the humidity setting inside the container (20). The home appliance (1) presented in Figure 1 is a domestic refrigerator. In the figure, the part of the refrigerator where the container (20) is provided is illustrated. The refrigerator in the figure comprises a housing (10) defined by an inner liner (11). The container (20) is positioned inside the housing (10). The container (20), provided in Figure 1, is the crisper of the refrigerator.

20

The container (20), in other words the crisper, comprises a drawer (21) having a front wall, a rear wall, two facing side walls and a base; and an external upper wall (22) covering the upper opening of the drawer (21) when the drawer (21) is in closed position. The upper wall (22) is a plate or a shelf positioned on the drawer (21).

25

There is an adjuster (30) on a front edge (224) of the upper wall (22) (Figure 2). The adjuster (30) can realize a sliding movement on the front edge (224) and along the front edge (224), and functions as a slide. The body (31) of the adjuster (30) is embodied in a compliant manner to the sliding movement. There is a cover (40) between the upper wall (22) and the drawer (21), preventing air and humidity exchange between the outer environment around the drawer (21) and the inner environment of the drawer (21) when desired. The cover (40) is movable between a closed position and an open position. The cover (40) is moved together with the adjuster (30). During the sliding movement, by means of a transfer element (33)

30

provided on the adjuster (30) and illustrated in Figure 4, the cover (40) is moving between said positions.

As exemplified in Figure-3, the present invention comprises an at least partially transparent display section (221) provided at a position close to the adjuster (30) and related to a certain humidity setting; and an indicator element (34) moving together with the adjuster (30) and making a sign (341) visible, describing that the related humidity setting is adjusted, in the display section (221).

10 The indicator element (34) is in plate form. It is connected to the adjuster (30) in an integrated manner. For this reason, there is a bridge element (32) extending from the rear face of the front wall (310) of an adjuster (30) towards the front edge (342) of the indicator element (34). Said transfer element (33) is provided in the joining point of the bridge element (32) and of the indicator element (34). When the adjuster (30) is connected to the front edge (224) of the upper wall (22), the indicator element (34) remains under the upper wall (22).  
15 The indicator element (34) is parallel with respect to the upper wall (22).

On the upper wall (22), there is a display section (221) providing the indicator element (34) to be at least partially visible at a position close to the adjuster (30) (Figure 5). The display section (221) is partially or completely transparent. In the possible embodiment in the figures, there are two display sections (221). While a display section (221) describes a high humidity setting, the other one describes a low humidity setting. In a compliant manner, at a point close to each display section (221), there is a humidity sign (222) describing which humidity setting it is related to.

25

On the indicator element (34), there is a sign (341) which is desired to be viewed through the display section (221). As illustrated in Figure 6, there is a sign (341) for each of the two display sections (221) described in Figure 5. The sign (341) in the figure is an approval sign and a colored floor is provided around the approval sign. When the humidity setting represented by the display section (221) is provided, the sign (341) is visible through the display section. For this reason, around of the display section (221) is made of a non-transparent material or it is embodied so as to be non-transparent. For instance, if the upper wall (22) is transparent, around of the display section (221) can be painted or printed such that it is not transparent. In the example in Figure 5, a print is applied.

30

In the same manner, a sign (341) is formed on the indicator element (34) by means of printing or painting methods. In a possible embodiment, each sign (341) has a different color. As exemplified in Figure 6, the sign (341) may also comprise a visual figure.

5

At a position close to the display section (221), there is an information element (223) illustrating the foodstuff the related humidity setting is compliant for (Figure 6). The information element (223) can also be obtained by means of printing or painting methods.

10 When the present invention is desired to be used, an upper wall (22) is positioned on the drawer (21) where an adjuster (30) is positioned on the front edge (224). The user slides the adjuster (30) towards the right or towards the left depending on the foodstuff placed into the container (20) and depending on the information in the information element (223) and/or  
15 depending on the humidity sign (222). When the desired setting is arrived, the sign (341), provided on the indicator element (34), becomes visible, and it is mentioned to the user that the related setting is provided. The related sign (341) helps a user, who didn't do the setting or forgot the setting adjusted, to see and learn the humidity setting of the container (20) when the user looks at the container (20). When the present setting desired to be changed and a different possible setting desired to be realized, the adjuster (30) is slid again however, in the  
20 opposite direction. By means of the sliding process, a sign (341) becomes visible in a different display section (221).

**Reference Numbers**

- |                                 |                              |
|---------------------------------|------------------------------|
| <b>1.</b> Home appliance        | <b>30.</b> Adjuster          |
| <b>10.</b> Housing              | <b>31.</b> Body              |
| <b>11.</b> Inner liner          | <b>310.</b> Front wall       |
| <b>20.</b> Container            | <b>32.</b> Bridge element    |
| <b>21.</b> Drawer               | <b>33.</b> Transfer element  |
| <b>22.</b> Upper wall           | <b>34.</b> Indicator element |
| <b>221.</b> Display section     | <b>341.</b> Sign             |
| <b>222.</b> Humidity sign       | <b>342.</b> Front edge       |
| <b>223.</b> Information element |                              |
| <b>224.</b> Front edge          | <b>40.</b> Cover             |

## CLAIMS

1. A home appliance (1), particularly a refrigerator, comprising a container (20); and an adjuster (30) adjusting humidity inside the container (20); and **characterized in that** the home appliance (1) comprises a display section (221) being related to a pre-determined humidity setting and at least partially transparent and provided in vicinity of adjuster (30); and an indicator element (34) making a sign (341), proving that the pre-determined humidity setting is set, visible through the display section (221) by moving with the adjuster (30).
2. A home appliance (1) according to claim 1; wherein the container (20) comprises a cover (40) moveable between a first position not allowing any leakage of humidity from the container (20) or allowing leakage in some amount and a second position allowing leakage of humidity from the container (20) more than the first position by the movement of the adjuster (30).
3. A home appliance (1) according to claim 2; wherein the adjuster (30) comprises a transfer element (33) connected to the cover (40) for transferring the movement of the adjuster (30).
4. A home appliance (1) according to anyone of the preceding claims; wherein the adjuster (30) comprises a body (31) configured as linearly slidable.
5. A home appliance (1) according to anyone of the preceding claims; wherein the home appliance (1) comprises two display sections (221), one for the highest possible humidity setting and one for the lowest possible humidity setting.
6. A home appliance (1) according to claim 4 or 5; wherein two display sections (221) are configured to be on a line parallel to a line on that the adjuster (30) slides.
7. A home appliance (1) according to claim 5 or 6; wherein the indicator element (34) comprises a different sign (341) for each of the display sections (221).
8. A home appliance (1) according to anyone of the preceding claims; wherein the indicator element (34) is a plate in connection with the adjuster (30).

**9.** A home appliance (1) according to anyone of the preceding claims; wherein a wall of the container (20) comprises the display section (221).

**10.** A home appliance (1) according to claim 9; wherein the wall of the container (20) comprising the display section (221) is an upper wall (22) of the container (20).  
5

**11.** A home appliance (1) according to anyone of the preceding claims; wherein the home appliance (1) comprises an information element (223) provided in vicinity of the display section (221) and indicating that the humidity setting related to the display section (221) is suitable for which fresh meal.  
10

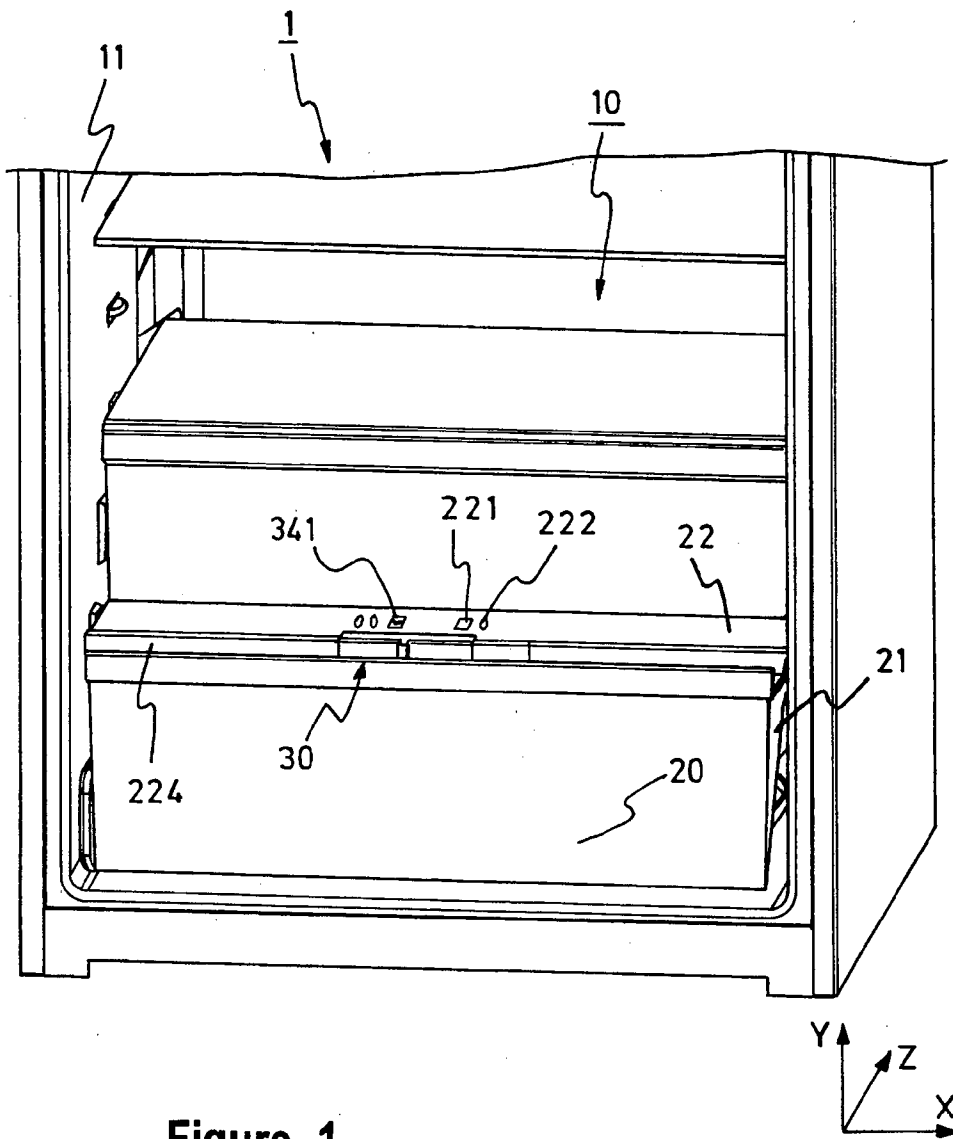

Figure- 1

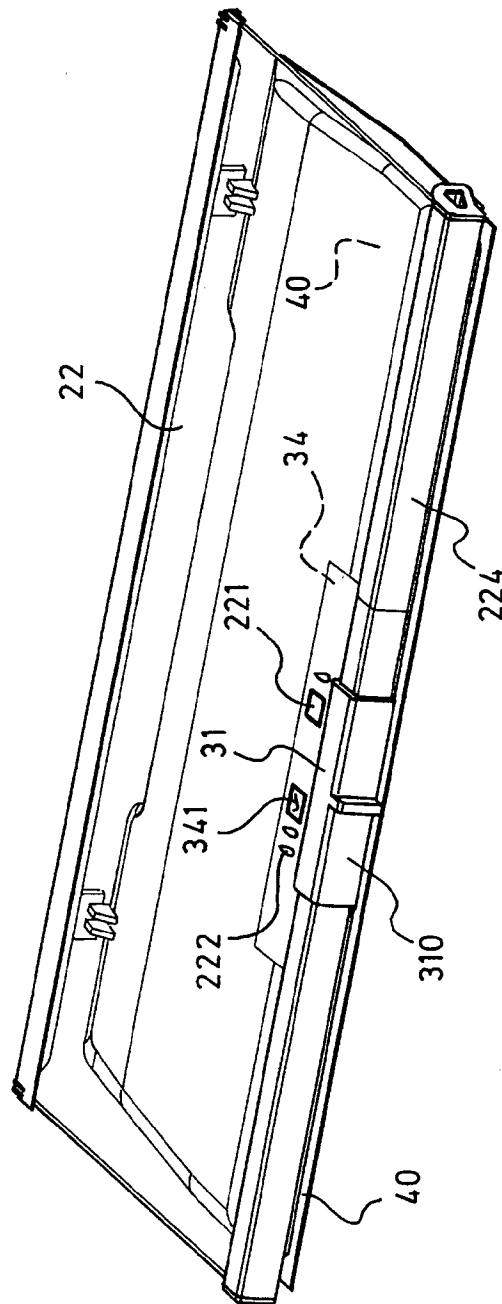

Figure- 2

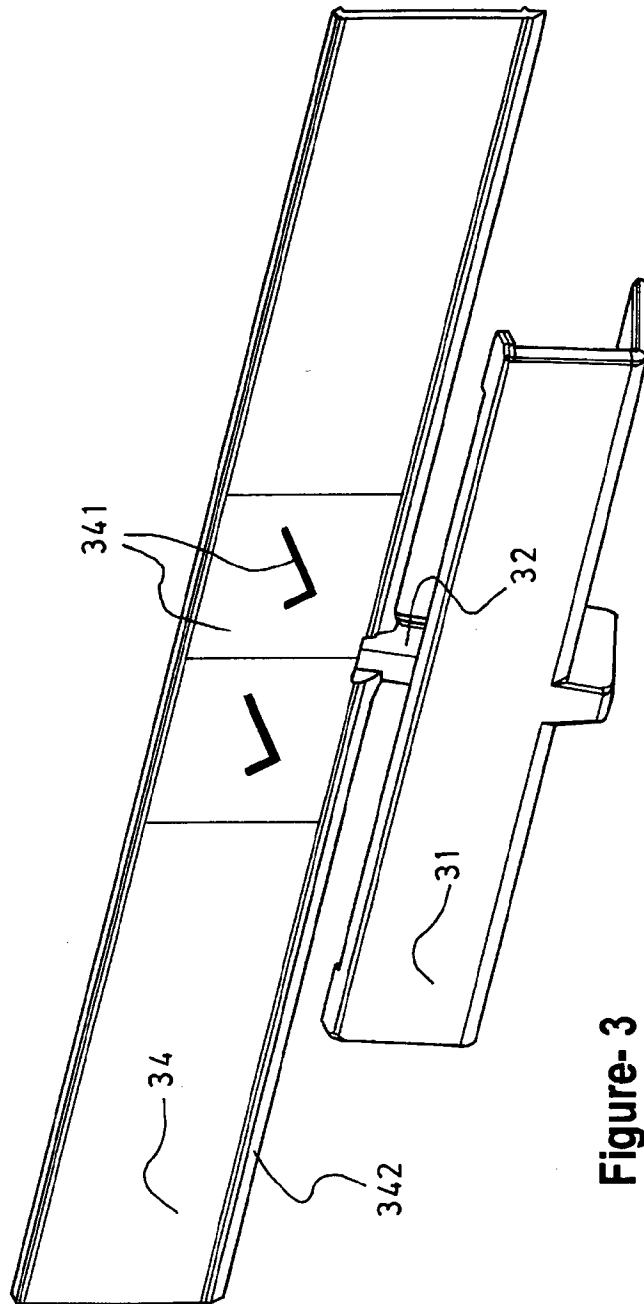
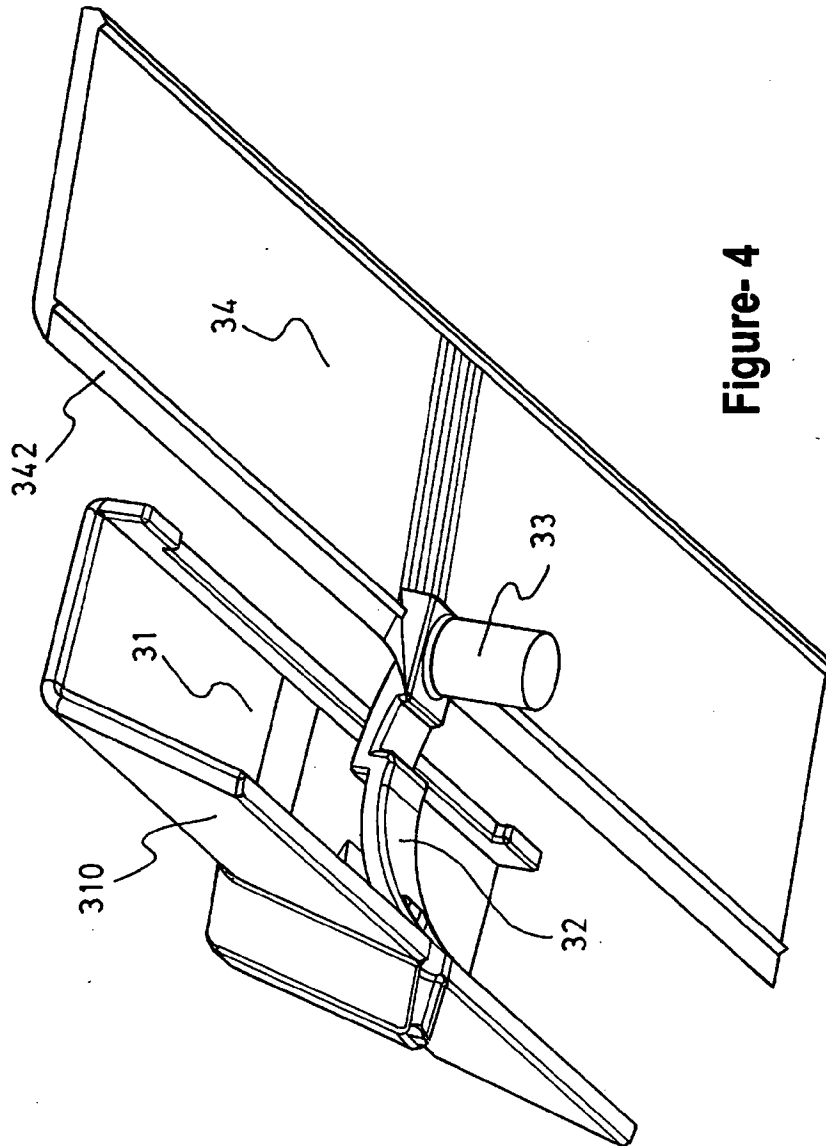

Figure-3



**Figure-4**

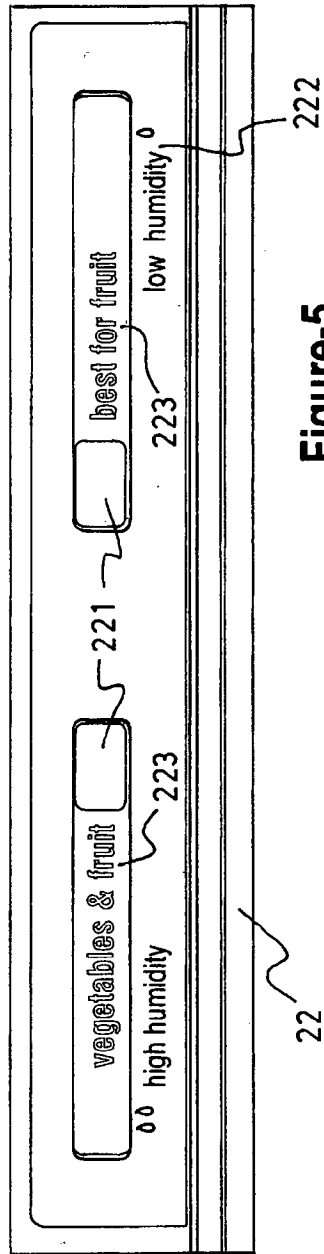

Figure-5

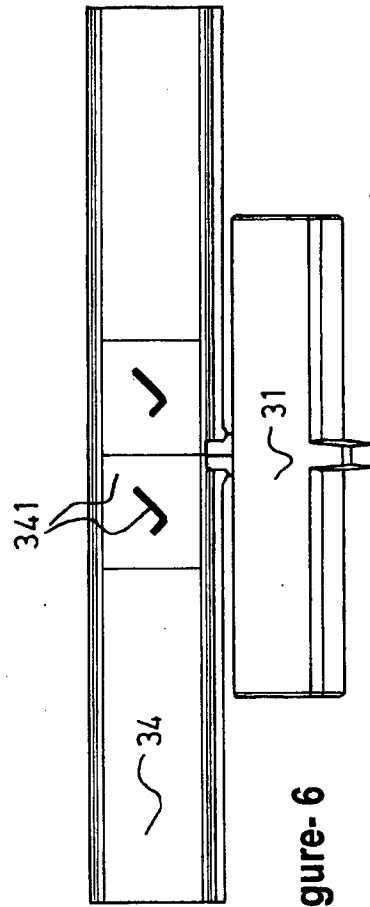

Figure-6

**INTERNATIONAL SEARCH REPORT**

International application No  
PCT/EP2014/065213

**A. CLASSIFICATION OF SUBJECT MATTER**  
 INV. F25D17/04 F25D25/02  
 ADD.  
 According to International Patent Classification (IPC) or to both national classification and IPC

**B. FIELDS SEARCHED**  
 Minimum documentation searched (classification system followed by classification symbols)  
 F25D  
 Documentation searched other than minimum documentation to the extent that such documents are included in the fields searched

Electronic data base consulted during the international search (name of data base and, where practicable, search terms used)  
 EPO-Internal

**C. DOCUMENTS CONSIDERED TO BE RELEVANT**

Category*	Citation of document, with indication, where appropriate, of the relevant passages	Relevant to claim No.
X	US 2004/177640 A1 (RAFALOVICH ALEXANDER PINKUS [US] ET AL) 16 September 2004 (2004-09-16) paragraphs [0018] - [0024]; figures -----	1,9,10
X	US 2 541 892 A (H.W.SCHULZE) 13 February 1951 (1951-02-13) column 3, line 19 - column 4, line 26; figures -----	1,8-10
Y	US 4 850 206 A (LARSEN) 25 July 1989 (1989-07-25) column 6, lines 1-62; figures -----	1-11
Y	GB 927 943 A (LOH KG OPTIK W) 6 June 1963 (1963-06-06) page 1, line 56 - page 3, line 65; figures -----	1-11

Further documents are listed in the continuation of Box C.

See patent family annex.

\* Special categories of cited documents :

- "A" document defining the general state of the art which is not considered to be of particular relevance
- "E" earlier application or patent but published on or after the international filing date
- "L" document which may throw doubts on priority claim(s) or which is cited to establish the publication date of another citation or other special reason (as specified)
- "O" document referring to an oral disclosure, use, exhibition or other means
- "P" document published prior to the international filing date but later than the priority date claimed

- "T" later document published after the international filing date or priority date and not in conflict with the application but cited to understand the principle or theory underlying the invention
- "X" document of particular relevance; the claimed invention cannot be considered novel or cannot be considered to involve an inventive step when the document is taken alone
- "Y" document of particular relevance; the claimed invention cannot be considered to involve an inventive step when the document is combined with one or more other such documents, such combination being obvious to a person skilled in the art
- "&" document member of the same patent family

Date of the actual completion of the international search <b>25 August 2014</b>	Date of mailing of the international search report <b>04/09/2014</b>
--	---

Name and mailing address of the ISA/ European Patent Office, P.B. 5818 Patentlaan 2 NL - 2280 HV Rijswijk Tel. (+31-70) 340-2040, Fax: (+31-70) 340-3016	Authorized officer <b>Vigilante, Marco</b>
--	---

# INTERNATIONAL SEARCH REPORT

Information on patent family members

International application No

PCT/EP2014/065213

Patent document cited in search report	Publication date	Patent family member(s)	Publication date
US 2004177640	A1	16-09-2004	NONE
US 2541892	A	13-02-1951	NONE
US 4850206	A	25-07-1989	NONE
GB 927943	A	06-06-1963	FR 1266801 A 17-07-1961 GB 927943 A 06-06-1963