

(No Model.)

A. MATHISON.
LACING STUD.

No. 525,152.

Patented Aug. 28, 1894.

Fig. 1.

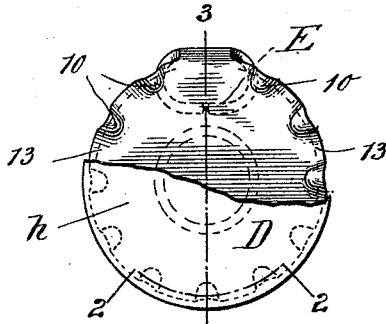

Fig. 2.

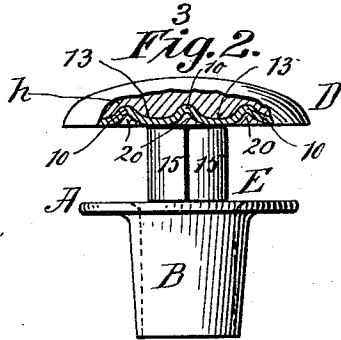

Fig. 5.

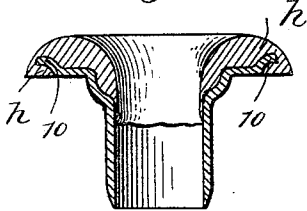

Fig. 6.

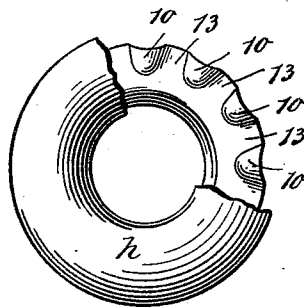

Fig. 3.

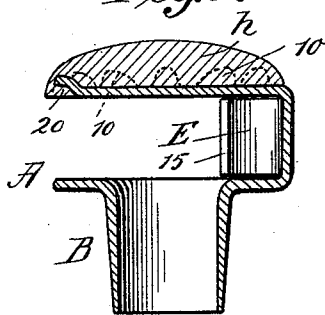
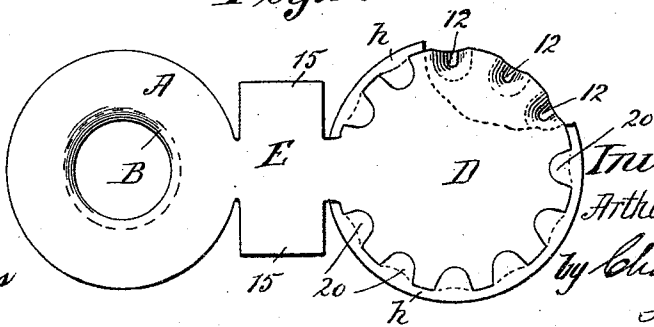

Fig. 4.



Witnesses:
John D. Garfield
H. J. Clemons

Inventor;
Arthur Mathison
by *Chapman*
Attorneys.

UNITED STATES PATENT OFFICE.

ARTHUR MATHISON, OF SPRINGFIELD, MASSACHUSETTS.

LACING-STUD.

SPECIFICATION forming part of Letters Patent No. 525,152, dated August 28, 1894,

Application filed February 16, 1894. Serial No. 500,416. (No model.)

To all whom it may concern:

Be it known that I, ARTHUR MATHISON, a citizen of the United States, residing at Springfield, in the county of Hampden and State of Massachusetts, have invented new and useful Improvements in Lacing-Studs, of which the following is a specification.

This invention relates to lacing studs and analogous fastening devices for shoes and other articles; the object being to improve the construction of such objects, all as hereinafter fully set forth.

In the drawings forming part of this specification, Figure 1 is a plan view, and Fig. 2 is a front elevation of a lacing stud, constructed according to my invention, the covering of the stud illustrated in Fig. 1 being partly broken away to show a portion of the metallic head thereunder. Fig. 3 is a sectional view of the stud on line 3—3, of Fig. 1. Fig. 4 is a plan view of the metallic blank from which the lacing stud is formed. Fig. 5 is a sectional view axially through an eyelet which embodies features of this invention, Fig. 6 being a plan view of the same with a portion of the plastic material covering the top rim of the eyelet broken away. Said figures show the stud greatly enlarged.

Certain of the improvements herein described and shown are applicable to the heads of buttons, eyelets, and othersimilar objects, on the outer surface of which it is desirable to apply, or attach, a non-metallic plastic material which shall cover said head and prevent the disagreeable effects of a worn metallic surface and provide means for making such head of different colors, according to the articles on which they are destined to be used.

The thin sheet-metal stud-blank (preferably brass) illustrated in Fig. 4, consists of three portions, or elements, viz.,—the body, A, having thereon the fastening eyelet, B; the head portion, D, of a general circular form having a series of corrugations at its border; and the part, E, located between said parts, A and D, and integral with the latter, of rectangular form, and from which that part of the stud structure designated the "post" is formed.

In view of the foregoing description of said blank, the base of the stud, under the head,

is designated by A, the metallic part of the head by D, and the post by E.

The above mentioned corrugations are constituted by striking up in a die, from the under side of the marginal portion of the head, and without severing or slitting the metal, suitably spaced protuberances, 10, which, of course, are hollow leaving the space, 12, beneath, and which leave at the top the intermediate depressions, 13, 13, all to the end of providing, as below described, for permanently securing to said head a covering of non-metallic plastic material.

In the manufacture of lacing studs from sheet metal, as heretofore practiced, the post, E, which constitutes the head and base uniting element of the stud, has been made substantially flat on its inner surface, or that surface which receives the lacing; but by the improved manner of constructing said post, herein set forth, the said post is produced in substantially a cylindrical form, or so nearly approximating that shape (see dotted lines showing the elliptical form of the post in Fig. 1) that the side against which the lacing is drawn when the stud is in use upon a shoe, or other article, practically is circular; consequently, the best conditions are presented for the durability of the lacing, and to effect other advantageous results below referred to and to obviate, entirely, the undue wear of the lacing when used against a stud having said flat lacing surface. The above mentioned substantially cylindrical form of said post is secured by providing the said intermediate rectangularly formed element of the blank, shown in Fig. 4, the extremities, 15, 15, of which central element are bent forward between the head, D, and the base, A, of the stud, thereby producing said substantially cylindrical form, as shown, and consequently forming the said convex face against which the shoe lacing is invariably drawn, which face presents no abrading surface, thus conducing to the greatest durability of the lacing and providing such a bearing surface therefor as conduces to a perfect freedom of motion of the lacing without the wearing effect which is ordinarily produced by the use of a flat-sided, or sharp-edged, post.

In constructing the metallic part of the stud

from the blank, (Fig. 4) the eyelet part, B, is drawn from the base, A, in the usual manner, the ends of the central, post-portion, E, are folded around and their edges brought together, or substantially so, to produce the said circular formed, or elliptical hollow, post, and the head, D, is bent to bring it directly over the base, A, or to the position shown in Figs. 2 and 3. This position of a large portion of the post between the head and the base of the stud toward the center thereof, supports the head against accidental deflection, and thus preserves the wide opening between the head and the base.

Fig. 4 illustrates the under, or back side of the head, D, and the top of the base, A.

The metallic portion of the stud, having been bent to the form above indicated, is then placed on a suitable plate or die on which the under side of the head of the stud lies closely, and there is then applied to the outer side of said head, a covering, *h*, of plastic material similar to hard rubber, or other well known plastic compositions which are softened by heat, and said material, by the aid of a hot die and pressure, is molded onto the stud-head, substantially in the form shown in Figs. 2, 3, and 4, and is thereby caused to cover the head and to adapt itself to the form of said marginal upset, hollow protuberances,—to enter the intermediate depressions, and to extend slightly beyond the edge of the corrugated metallic part of the head of the plastic material, while portions of the plastic material, assuming the form of an internal gear, embed themselves, as seen at 20 in Figs. 2, 3, and 4, in the depressions constituted beneath the upset protuberances of the corrugations. Upon becoming cool, the said covering, *h*, of plastic material, is firmly and permanently fixed on the head, D, of the stud. The said plastic material, as is well known, may be made of various colors according to the color of the leather, or other material on which it is to be worn.

As shown in Figs. 2, 3, and 5 the plastic material will flow over the edge of the corrugated metallic head, and under the raised parts of the radial corrugations thus filling the spaces 12, but this material will not flow under the depressed portions 13 of the head as these parts 13 rest on the die. A bottom view of the completed head will show radial metallic ribs running from near the central post to near the periphery of the head, and between these ribs are portions of the plastic material.

From the foregoing description of the means herein set forth for uniting a suitable plastic covering to the head of the stud, herein shown, it is obvious that the same means may be advantageously employed for attaching covering layers of plastic material onto the metal base of buttons, and analogous articles; and in Figs. 5 and 6 the same idea of

means is utilized in an obvious manner in applying and anchoring the plastic covering upon the metallic annular rim of an eyelet which has the marginal upset indentations and intermediate depressions.

There have been, heretofore, numerous constructions, means, and methods of affixing to lacing studs, buttons, and eyelets, a layer or body of plastic material, resembling rubber or celluloid to constitute the wearing face. Many of these, while ingenious, and fairly efficient after their production, are produced by the use of expensive dies and machinery which are necessarily slow and involve mechanical operations which practically prohibit the production of the studs, or eyelets, at a marketable figure; and, again, on the other hand, many of the plastic faced studs which have been produced have possessed features which rendered them undesirable, especially in point of a structurally weakened metallic foundation for the plastic, and an inefficient capability for the anchoring of the plastic upon the metallic supporting body therefor. But by the exercise of the present invention the part of the stud to receive the plastic material may be formed, as shown, most cheaply and rapidly and without weakening, but on the other hand, strengthening the rim of the head; moreover, constructions of dies for applying and setting the plastic may be employed which are, first, simpler and cheaper than any heretofore known or used; secondly, capable of more rapid operation than it is believed has been heretofore possible, and, thirdly, adapted to so coact with the peculiarly constructed metallic head as to insure the proper support of the corrugated rim while the plastic is being set with hard pressure thereagainst and thereupon. This latter mentioned provision of having the part of the stud receiving the plastic material firmly supported by one member of the die while the other die member is hard pressing the plastic to its anchoring engagement, and molding the same to external form, and without having to depend upon the rigidity of the thin metal head, is very important and valuable.

Having thus described my invention, what I claim, and desire to secure by Letters Patent, is—

The eyelet or stud having a metallic head with elevations and depressions extending outward from near the post to the periphery of said metallic head, and a plastic cover extending over said metallic head and outside the periphery thereof, and filling the recesses under the elevated portions of the metal, the depressions in the metal being exposed, substantially as described.

ARTHUR MATHISON.

Witnesses:

H. A. CHAPIN,
K. I. CLEMONS.