

- (51) International Patent Classification: Not classified
- (21) International Application Number: PCT/US2015/045238
- (22) International Filing Date: 14 August 2015 (14.08.2015)
- (25) Filing Language: English
- (26) Publication Language: English
- (30) Priority Data: 14/461,277 15 August 2014 (15.08.2014) US
- (63) Related by continuation (CON) or continuation-in-part (CIP) to earlier application: US 14/461,277 (CON) Filed on 15 August 2014 (15.08.2014)
- (71) Applicant: DAQRI, LLC [US/US]; 1201 West 5th Street, Suite T 800, Los Angeles, California 90017 (US).
- (72) Inventors: MULLINS, Brian; 170 Adams St., Sierra Madre, California 91024 (US). KAMMERAIT, Matthew; 1355 N Sierra Bonita Ave., #401, West Hollywood, California 90046 (US). IRVING, Frank Chester Jr.; 22714 Margarita Drive, Woodland Hills, California 91364 (US).
- (74) Agents: SCHEER, Bradley et al.; Schwegman, Lundberg & Woessner, P.A., P.O. Box 2938, Minneapolis, Minnesota 55402 (US).
- (81) Designated States (unless otherwise indicated, for every kind of national protection available): AE, AG, AL, AM, AO, AT, AU, AZ, BA, BB, BG, BH, BN, BR, BW, BY, BZ, CA, CH, CL, CN, CO, CR, CU, CZ, DE, DK, DM, DO, DZ, EC, EE, EG, ES, FI, GB, GD, GE, GH, GM, GT, HN, HR, HU, ID, IL, IN, IR, IS, JP, KE, KG, KN, KP, KR, KZ, LA, LC, LK, LR, LS, LU, LY, MA, MD, ME, MG, MK, MN, MW, MX, MY, MZ, NA, NG, NI, NO, NZ, OM, PA, PE, PG, PH, PL, PT, QA, RO, RS, RU, RW, SA, SC, SD, SE, SG, SK, SL, SM, ST, SV, SY, TH, TJ, TM, TN, TR, TT, TZ, UA, UG, US, UZ, VC, VN, ZA, ZM, ZW.
- (84) Designated States (unless otherwise indicated, for every kind of regional protection available): ARIPO (BW, GH, GM, KE, LR, LS, MW, MZ, NA, RW, SD, SL, ST, SZ, TZ, UG, ZM, ZW), Eurasian (AM, AZ, BY, KG, KZ, RU, TJ, TM), European (AL, AT, BE, BG, CH, CY, CZ, DE, DK, EE, ES, FI, FR, GB, GR, HR, HU, IE, IS, IT, LT, LU, LV, MC, MK, MT, NL, NO, PL, PT, RO, RS, SE, SI, SK, SM, TR), OAPI (BF, BJ, CF, CG, CI, CM, GA, GN, GQ, GW, KM, ML, MR, NE, SN, TD, TG).
- Published: — without international search report and to be republished upon receipt of that report (Rule 48.2(g))

(54) Title: SPATIAL DATA VISUALIZATION

602 DATA HEADER	CONTEXTUAL HEADER	DEVICE IDENTIFIER SESSION IDENTIFIER LOCATION INFORMATION DEVICE TYPE			
	604 PATH HEADER	PATH START TIME NAME/TYPE OF SENSORS TOTAL PATH DURATION TOTAL PATH DISTANCE			
606 SENSOR HEADER	SENSOR 1 NAME TYPE INITIAL CALIBRATION FREQUENCY THRESHOLD # OF SAMPLES	SENSOR 2 NAME TYPE INITIAL CALIBRATION FREQUENCY THRESHOLD # OF SAMPLES	• • •	SENSOR N NAME TYPE INITIAL CALIBRATION FREQUENCY THRESHOLD # OF SAMPLES	
		608 DATA PAYLOAD			
608 DATA PAYLOAD	SENSING DATA	SENSOR 1 SAMPLE SAMPLE NUMBER (FREQ/THRESHOLD) RELATIVE TIME DURATION % TIME % (SENSOR SPECIFIC SAMPLE DATA)	SENSOR 2 SAMPLE SAMPLE NUMBER (FREQ/THRESHOLD) RELATIVE TIME DURATION % TIME % (SENSOR SPECIFIC SAMPLE DATA)	• • •	SENSOR N SAMPLE SAMPLE NUMBER (FREQ/THRESHOLD) RELATIVE TIME DURATION % TIME % (SENSOR SPECIFIC SAMPLE DATA)

FIG. 6

(57) Abstract: A system and method for spatial data visualization are described. An analytics computation of users' interactions with an augmented reality content is performed based on a physical object captured by a viewing device. The analytics computation comprises a computation of geometric paths of the users' interactions with the augmented reality content. A display of a visualization of the analytics computation is displayed based on the computation of the geometric paths of the users' interactions with the augmented reality content.

WO 2016/025811 A2

SPATIAL DATA VISUALIZATION

CROSS-REFERENCE TO RELATED APPLICATIONS

[0001] This application claims the benefit of U.S. Application Serial No. 14/461,277, filed August 15, 2014, which is incorporated herein by reference in its entirety.

TECHNICAL FIELD

[0002] The subject matter disclosed herein generally relates to the visualization of processed data. Specifically, the present disclosure addresses systems and methods for spatial data visualization for augmented reality (AR) experiences.

BACKGROUND

[0003] A device can be used to generate and display data in addition to an image captured with the device. For example, AR is a live, direct or indirect view of a physical, real-world environment whose elements are augmented by computer-generated sensory input such as sound, video, graphics or Global Positioning System (GPS) data. With the help of advanced AR technology (e.g., adding computer vision and object recognition), information about the surrounding real world of the user becomes interactive. Device-generated (e.g., artificial) information about the environment and its objects can be overlaid on the real world.

[0004] The ability to process spatial data in conjunction with an augmented reality experience (as well as in conjunction with other sensor streams) provides unprecedented analysis capabilities. However, the analytical processing may be extremely time intensive given the multidimensional data from multiple sensors.

BRIEF DESCRIPTION OF THE DRAWINGS

[0005] Some embodiments are illustrated by way of example and not limitation in the figures of the accompanying drawings.

[0006] **FIG. 1** is a block diagram illustrating an example of a network suitable for spatial data collection for augmented reality experiences, according to some example embodiments.

[0007] **FIG. 2** is a block diagram illustrating an example embodiment of modules (e.g., components) of a viewing device.

[0008] **FIG. 3** is a block diagram illustrating an example embodiment of modules of a data aggregation module.

[0009] **FIG. 4A** is a block diagram illustrating an example embodiment of modules of a server.

[0010] **FIG. 4B** is a block diagram illustrating an example embodiment of a path bundle processing module.

[0011] **FIG. 4C** is a block diagram illustrating an example embodiment of a visualization module.

[0012] **FIG. 5** is a diagram illustrating an example embodiment of a path bundle packaged data model.

[0013] **FIG. 6** is a diagram illustrating another example of a path bundle packaged data model.

[0014] **FIG. 7** is a diagram illustrating another example of a path bundle packaged data model.

[0015] **FIG. 8** is a diagram illustrating an example of a path bundle streaming data model.

[0016] **FIG. 9A** is a ladder diagram illustrating an example embodiment of an operation of spatial data visualization.

[0017] **FIG. 9B** is a ladder diagram illustrating another example embodiment of an operation of spatial data visualization.

[0018] **FIG. 9C** is a ladder diagram illustrating another example embodiment of an operation of spatial data visualization.

[0019] **FIG. 10** is a flowchart illustrating an example operation of spatial data collection at a viewing device.

[0020] **FIG. 11** is a flowchart illustrating an example operation of spatial data processing at a server.

[0021] **FIG. 12** is a flowchart illustrating an example operation of spatial data visualization at a server.

[0022] **FIG. 13** is a flowchart illustrating another example operation of spatial data visualization at a server.

[0023] **FIG. 14** is a block diagram illustrating components of a machine, according to some example embodiments, able to read instructions from a machine-readable medium and perform any one or more of the methodologies discussed herein.

[0024] **FIG. 15** is a block diagram illustrating a mobile device, according to an example embodiment.

[0025] **FIG. 16** is a diagram illustrating an example of visualization.

[0026] **FIG. 17** is a diagram illustrating another example of visualization.

[0027] **FIG. 18** is a diagram illustrating another example of visualization.

[0028] **FIG. 19** is a diagram illustrating another example of visualization.

DETAILED DESCRIPTION

[0029] Example methods and systems are directed to spatial data processing and visualization of augmented reality. Examples merely typify possible variations. Unless explicitly stated otherwise, components and functions are optional and may

be combined or subdivided, and operations may vary in sequence or be combined or subdivided. In the following description, for purposes of explanation, numerous specific details are set forth to provide a thorough understanding of example embodiments. It will be evident to one skilled in the art, however, that the present subject matter may be practiced without these specific details.

[0030] Augmented reality applications allow a user to experience information, such as in the form of a virtual object such as a three-dimensional (3D) virtual object overlaid on an image of a physical object captured with a camera of a viewing device. The physical object may include a visual reference (e.g., a recognized image, pattern, or object) that the augmented reality application can identify. A visualization of the additional information, such as the three-dimensional virtual object overlaid or engaged with an image of the physical object, is generated in a display of the viewing device. The three-dimensional virtual object may be selected based on the recognized visual reference or captured image of the physical object. A rendering of the visualization of the three-dimensional virtual object may be based on a position of the display relative to the visual reference. Other augmented reality applications allow a user to experience visualization of the additional information overlaid on top of a view or an image of any object in the real physical world. The virtual object may include a three-dimensional virtual object or a two-dimensional virtual object. For example, the three-dimensional virtual object may include a three-dimensional view of a chair or an animated dinosaur. The two-dimensional virtual object may include a two-dimensional view of a dialog box, menu, or written information such as statistics information for properties or physical characteristics of the object (e.g., temperature, mass, velocity, tension, stress). An image of the virtual object may be rendered at the viewing device or at a server in communication with the viewing device.

[0031] A system and method for spatial data visualization are described. An analytics computation of users' interactions with an augmented reality content is performed based on a physical object captured by a viewing device. The analytics computation comprises a computation of geometric paths of the users' interactions

with the augmented reality content. A display of a visualization of the analytics computation is displayed based on the computation of the geometric paths of the users' interactions with the augmented reality content.

[0032] In an example embodiment, the display includes a heatmap identifying areas with a relatively higher number of user's interactions with the augmented reality content. The display may also include trajectory paths of the users' interactions with the augmented reality content, with the trajectory paths identifying rotations and movements of the augmented reality content caused by the users' interactions. The display may also include an identification of the most common trajectory paths of the user's interactions with the augmented reality content.

[0033] In another example embodiment, the geometric paths of the users' interactions comprise a geometric trajectory based on a dwelling time exceeding a threshold for a view of the augmented reality content.

[0034] In another example embodiment, a path bundle processing module accesses and processes path bundle data packages received from the viewing device. The path bundle data packages describe a user's interaction of the viewing device with the augmented reality content based on a physical object captured by the viewing device. The path bundle data packages are generated based on sensor data using a data model comprising a data header and a data payload. The data header comprises a contextual header having data identifying the viewing device and a user of the viewing device. A path header may have data identifying a path of the user interaction with the augmented reality content. A sensor header may have data identifying a plurality of sensors. The data payload may include dynamically sized sampling data from the sensor data. The path bundle processing module comprises a normalization module that normalizes the path bundle data packages. An aggregation module aggregates the normalized path bundle data packages. The analytics module performs the analytics computation on the normalized and aggregated path bundle data packages.

[0035] In another example embodiment, the analytics module is configured to generate an extension of the data model to represent the normalized and aggregated

path bundle data packages, to access trigger conditions, to perform the analytics computation on the extension of the data model based on the trigger conditions, and to identify a spatial pattern based on the trigger conditions.

[0036] In another example embodiment, the normalization and the aggregation modules may normalize and aggregate spatial and sensor data from multiple sources across multiple dimensions from the path to filter singular and aggregate data.

[0037] In another example embodiment, the analytics module may identify spatial patterns for accidents and event predictions, recognize similar patterns and warn operators of the viewing device, assign weighting schemes for switching amongst sensors of the viewing device, identify user focus points and user loss of focus and redirect the user, rank task complexity and calibrate user skill levels based on the normalized and aggregated path bundle data packages, and identify spatial movement-based gestures and interfaces based on the normalized and aggregated path bundle data packages.

[0038] In another example embodiment, the sensor data is related to a position and an orientation of the viewing device over time. The plurality of sensors comprises optical sensors and inertia sensors. The contextual header includes a viewing device identifier, a session identifier, a physical location, and a viewing device type. The path header includes a path start time, a path end time, a type of sensor identifier for each corresponding sensor, a total duration of the path, and a total distance of the path. The sensor header comprises, for each sensor, a sensor identifier, a sensor position identifier, three dimensional position data, orientation data, and a number of data samples. The dynamically sized sampling data includes a sensor identifier, a data sample number, a relative time, a duration percentage through the path, and a time percentage through the path.

[0039] **FIG. 1** is a network diagram illustrating a network environment 100 suitable for operating an augmented reality application of a viewing device, according to some example embodiments. The network environment 100 includes a viewing device 101 and a server 110, communicatively coupled to each other via a network 108. The viewing device 101 and the server 110 may each be implemented

in a computer system, in whole or in part, as described below with respect to **FIGS. 12 and 13**.

[0040] The server 110 may be part of a network-based system. For example, the network-based system may be or include a cloud-based server system that provides additional information, such as three-dimensional models or other virtual objects, to the viewing device 101.

[0041] A user 102 may utilize the viewing device 101 to capture a physical object 116 in a real world physical environment 114 viewed by the user 102. The user 102 may be a human user (e.g., a human being), a machine user (e.g., a computer configured by a software program to interact with the viewing device 101), or any suitable combination thereof (e.g., a human assisted by a machine or a machine supervised by a human). The user 102 is not part of the network environment 100, but is associated with the viewing device 101 and may be a user 102 of the viewing device 101. For example, the viewing device 101 may be a computing device with a display such as a smartphone, a tablet computer, a wearable computing device (e.g., watch or glasses), or a head-mounted computing device (e.g. helmet). The computing device may be hand held or may be removably mounted to the head of the user 102. In one example, the display may be a screen that displays what is captured with a camera of the viewing device 101. In another example, the display of the viewing device 101 may be transparent or semi-transparent such as in lenses of wearable computing glasses or the visor of a helmet. The viewing device may include optical and non-optical sensors for identifying the physical object 116 and the position and orientation of the viewing device 101 relative to the physical object 116.

[0042] The user 102 may be a user of an augmented reality application in the viewing device 101 and at the server 110. The augmented reality application may provide the user 102 with an augmented experience triggered by identified objects or references in the physical environment 114. The physical environment 114 may include identifiable objects such as a two-dimensional physical object (e.g., a picture), a three-dimensional physical object (e.g., a factory machine), a location

(e.g., at the bottom floor of a factory), or any references (e.g., perceived corners of walls or furniture) in the real world physical environment 114. For example, the user 102 may point a camera of the viewing device 101 to capture an image of the physical object 116.

[0043] In one embodiment, the objects in the image are tracked and recognized locally in the viewing device 101 using a local context recognition dataset or any other previously stored dataset of the augmented reality application of the viewing device 101. The local context recognition dataset module may include a library of virtual objects associated with real-world physical objects or references. In one example, the viewing device 101 identifies feature points in an image of the physical object 116 to determine different planes (e.g., edges, corners, surface). The viewing device 101 also identifies tracking data related to the physical object 116. For example, the tracking data may include a GPS location of the viewing device, an orientation and direction of the viewing device, the distance between the viewing device and the physical object. If the captured image is not recognized locally at the viewing device 101, the viewing device 101 downloads additional information (e.g., the three-dimensional model) corresponding to the captured image, from a database of the server 110 over the network 108.

[0044] In another embodiment, the image of the physical object 116 is tracked and recognized remotely at the server 110 using a remote context recognition dataset or any other previously stored dataset of an augmented reality application in the server 110. The remote context recognition dataset module may include a library of virtual objects associated with real-world physical objects or references.

[0045] Sensors 112 may be associated with, coupled to, or related to the physical object 116 in the physical environment 114 to measure properties of the physical object 116. Examples of measured physical properties may include, but are not limited to, weight, pressure, temperature, velocity, direction, position, intrinsic and extrinsic properties, acceleration, and dimensions. For example, the sensors 112 may include a blood pressure and heart rate monitor coupled to a subject. For example, the server 110 can generate a picture or a virtual three-dimensional model

of a heart with a beating animation with a pace corresponding to the measured heart rate from the sensors 112. The server 110 may change a color in corresponding portions of the heart based on the measured blood pressure. The live animation is provided to the viewing device 101 such that the picture of the heart is displayed on top of a chest area of the subject in the display of the viewing device 101. The position of the picture of the heart may be determined based on the orientation and position of the viewing device 101 relative to the subject using sensors (e.g., gyroscope) internal to the viewing device 101.

[0046] In another embodiment, the sensors 112 may include other sensors used to track the location, movement, and orientation of the viewing device 101 externally without having to rely on the sensors internal to the viewing device 101. The sensors 112 may include optical sensors (e.g., depth-enabled three-dimensional camera), wireless sensors (Bluetooth, Wi-Fi), GPS sensors, and audio sensors to determine the location of the user 102 having the viewing device 101, distance of the user 102 to the tracking sensors 112 in the physical environment 114 (e.g., sensors 112 placed in corners of a venue or a room), and the orientation of the viewing device 101 to track what the user 102 is looking at (e.g., direction at which the viewing device 101 is pointed, e.g., viewing device 101 pointed towards a player on a tennis court, viewing device 101 pointed at a person in a room).

[0047] In another embodiment, data from the sensors 112 and internal sensors in the viewing device 101 may be used for analytics data processing at the server 110 (or another server) for analysis on usage and how the user 102 is interacting with the physical environment 114 and the virtual content based on the physical object 116. Live data from other servers may also be used in the analytics data processing. For example, the analytics data may track at what locations (e.g., points or features) on the physical or virtual object the user 102 has looked, how long the user 102 has looked at each location on the physical or virtual object, how the user 102 held the viewing device 101 when looking at the physical or virtual object, which features of the virtual object the user 102 interacted with (e.g., such as whether the user 102 tapped on a link in the virtual object), and any suitable

combination thereof. The viewing device 101 receives a visualization content dataset related to the analytics data. The viewing device 101 then generates a virtual object with additional or visualization features, or a new experience, based on the visualization content dataset.

[0048] Any of the machines, databases, or devices shown in **FIG. 1** may be implemented in a general-purpose computer modified (e.g., configured or programmed) by software to be a special-purpose computer to perform one or more of the functions described herein for that machine, database, or device. For example, a computer system able to implement any one or more of the methodologies described herein is discussed below with respect to **FIGS. 12, 13**. As used herein, a “database” is a data storage resource and may store data structured as a text file, a table, a spreadsheet, a relational database (e.g., an object-relational database), a triple store, a hierarchical data store, or any suitable combination thereof. Moreover, any two or more of the machines, databases, or devices illustrated in **FIG. 1** may be combined into a single machine, and the functions described herein for any single machine, database, or device may be subdivided among multiple machines, databases, or devices.

[0049] The network 108 may be any network that enables communication between or among machines (e.g., server 110), databases, and devices (e.g., viewing device 101). Accordingly, the network 108 may be a wired network, a wireless network (e.g., a mobile or cellular network), or any suitable combination thereof. The network 108 may include one or more portions that constitute a private network, a public network (e.g., the Internet), or any suitable combination thereof.

[0050] **FIG. 2** is a block diagram illustrating modules (e.g., components) of the viewing device 101, according to some example embodiments. The viewing device 101 may include sensors 202, a display 204, a processor 206, and a storage device 208. For example, the viewing device 101 may be a wearable computing device (e.g., glasses or helmet), a desktop computer, a vehicle computer, a tablet computer, a navigational device, a portable media device, or a smart phone of a user. The user may be a human user (e.g., a human being), a machine user (e.g., a

computer configured by a software program to interact with the viewing device 101), or any suitable combination thereof (e.g., a human assisted by a machine or a machine supervised by a human).

[0051] The sensors 202 may include, for example, a proximity or location sensor (e.g., Near Field Communication, GPS, Bluetooth, Wi-Fi), an optical sensor (e.g., infrared camera, time of flight sensors, structured light sensors), inertial sensors, compass, gyroscope, temperature sensors, humidity sensors, an audio sensor (e.g., a microphone), or any suitable combination thereof. For example, the sensors 202 may include a rear facing camera and a front facing camera in the viewing device 101. It is noted that the sensors 202 described herein are for illustration purposes; the sensors 202 are thus not limited to the ones described. The sensors 202 may be used to generate internal tracking data of the viewing device 101 to determine what the viewing device 101 is capturing or looking at in the real physical world.

[0052] The display 204 may include, for example, a touchscreen display configured to receive a user input via a contact on the touchscreen display. In one example, the display 204 may include a screen or monitor configured to display images generated by the processor 206. In another example, the display 204 may be transparent or semi-opaque so that the user 102 can see through the display 204 (e.g., Head-Up Display, see through screen).

[0053] The processor 206 may include an AR application 216 for generating a display of a three-dimensional virtual object related to a physical object captured by the viewing device 101. In one example embodiment, the AR application 216 may include an augmented reality processing module 214 and a data aggregation module 218.

[0054] The augmented reality processing module 214 identifies a physical object to which the viewing device 101 is pointed. The augmented reality processing module 214 may detect, generate, and identify identifiers such as feature points of the physical object being viewed or pointed at the viewing device 101 using an optical device of the viewing device 101 to capture the image of the

physical object. As such, the augmented reality processing module 214 may be configured to identify one or more physical objects. The identification of the object may be performed in many different ways. For example, feature points of the physical object may be determined based on several image frames of the physical object. The identity of the physical object may be also determined using any visual recognition algorithm. In another example, a unique identifier may be associated with the physical object. The unique identifier may be a unique wireless signal or a unique visual pattern such that the augmented reality processing module 214 can look up the identity of the physical object based on the unique identifier from a local or remote content database. In another example embodiment, the augmented reality processing module 214 includes a facial recognition algorithm to determine an identity of a subject or object. The augmented reality processing module 214 may be configured to determine whether the captured image matches an image locally stored in a local database of images and corresponding additional information (e.g., three-dimensional model and interactive features) on the viewing device 101. In one embodiment, the augmented reality processing module 214 retrieves a primary content dataset from the server 110 and generates and updates a contextual content dataset based on an image captured with the viewing device 101.

[0055] The augmented reality processing module 214 may include a local rendering engine that generates a visualization of a three-dimensional virtual object overlaid on (e.g., superimposed upon, or otherwise displayed in tandem with) an image of a physical object captured by a camera of the viewing device 101 in the display 204 of the viewing device 101. A visualization of the three-dimensional virtual object may be manipulated by adjusting a position of the physical object (e.g., its physical location, orientation, or both) relative to the camera of the viewing device 101. Similarly, the visualization of the three-dimensional virtual object may be manipulated by adjusting a position of the camera of the viewing device 101 relative to the physical object.

[0056] In another example embodiment, the augmented reality processing module 214 may retrieve three-dimensional models of virtual objects associated

with a captured real world object. For example, the captured image may include a visual reference (also referred to as a marker) that consists of an identifiable image, symbol, letter, number, or machine-readable code. For example, the visual reference may include a bar code, a quick response (QR) code, or an image that has been previously associated with a three-dimensional virtual object (e.g., an image that has been previously determined to correspond to the three-dimensional virtual object).

[0057] The data aggregation module 218 may be configured to access data from the sensors 202 and aggregate the data using a path bundle packaged data model. The data aggregation module 218 collects spatial positioning, movement, and sensor data attached to an AR event flow. This process includes the data organization format and process for linking the positioning, movement, and sensor data to other non-spatial/sensor data. In an example embodiment, the path bundle packaged data model includes separating the data into a header that contains contextual and technical/calibration information, and the payload, which contains the actual spatial and sensor data. The header information is organized to contain information specific to the path context, like the AR session linked to the path, the time, the location (which may be moved to the payload), the device type, the user, and so forth. The header also includes technical/calibration information specific to the path data itself, such as a listing of all the sensors being captured, specific data about their frequency/thresholds, an initial camera matrix, start time/end time, and so forth. The payload contains the spatial/sensor data encapsulated in such a way that multiple data points can be tied together when processing (typically via time, but also possibly through other means like step number, or percentage of path). The creation of this data model allows the capture of spatial and analytics data across multiple devices and combines/aggregates/filters it as necessary without modifying the original pure data stream.

[0058] The AR visualization module 220 generates analytics visualization on the AR content. For example, a heatmap may be generated on the AR content to identify most viewed areas or regions of interest from users. The data for the

analytics visualization may be generated at the server 110 and received at the AR visualization module 220.

[0059] In an example embodiment and referring to **FIG. 3**, the data aggregation module 218 includes a contextual data module 302, a path data module 304, a sensor data module 306, and a bundle module 308. The contextual data module 302 generates data related to the user and the viewing device attached to the path. Data may change from path to path but may not be directly related to data samples collected. The path data module 304 generates data related to the corresponding path bundle. That data may change from each data sample instead of a new path, but may not change for all the sample points within the path. The data from the path data module 304 may also list a number and type of sensors from which data is collected. The sensor data module 306 generates data related to each specific sensor for a path. For example, the data from the sensor data module 306 may include technical information about their collection such as the sample frequency or the threshold that will trigger a non-frequency-based sample. The bundle module 308 aggregates data from the contextual data module 302, path data module 304, and sensor data module 306, as well as sampling data from the sensors using a path bundle packaged data model. The sampling data includes, for example, dynamically sized series of data samples that indicate which sensor is used, the time of the sample, the step number of the sample, whether it was frequency or threshold triggered, and so forth.

[0060] The storage device 208 may be configured to store the path bundle packaged data, database of identifiers of physical objects, tracking data, and corresponding virtual user interfaces. In another embodiment, the storage device 208 may also include visual references (e.g., images) and corresponding experiences (e.g., three-dimensional virtual objects, interactive features of the three-dimensional virtual objects). For example, the visual reference may include a machine-readable code or a previously identified image (e.g., a picture of a shoe). The previously identified image of the shoe may correspond to a three-dimensional virtual model of the shoe that can be viewed from different angles by manipulating the position of

the viewing device 101 relative to the picture of the shoe. Features of the three-dimensional virtual shoe may include selectable icons on the three-dimensional virtual model of the shoe. An icon may be selected or activated by tapping on or moving the viewing device 101.

[0061] In one embodiment, the storage device 208 includes a primary content dataset, a contextual content dataset, and a visualization content dataset. The primary content dataset includes, for example, a first set of images and corresponding experiences (e.g., interaction with three-dimensional virtual object models). For example, an image may be associated with one or more virtual object models. The primary content dataset may include a core set of images or the most popular images determined by the server 110. The core set of images may include a limited number of images identified by the server 110. For example, the core set of images may include the images depicting covers of the ten most popular magazines and their corresponding experiences (e.g., virtual objects that represent the ten most popular magazines). In another example, the server 110 may generate the first set of images based on the most popular or often scanned images received at the server 110. Thus, the primary content dataset does not depend on objects or images scanned by AR processing module 214.

[0062] The contextual content dataset includes, for example, a second set of images and corresponding experiences (e.g., three-dimensional virtual object models) retrieved from the server 110. For example, images captured with the viewing device 101 that are not recognized (e.g., by the server 110) in the primary content dataset are submitted to the server 110 for recognition. If the captured image is recognized by the server 110, a corresponding experience may be downloaded at the viewing device 101 and stored in the contextual content dataset. Thus, the contextual content dataset relies on the context in which the viewing device 101 has been used. As such, the contextual content dataset depends on objects or images scanned by the AR processing module 214 of the viewing device 101.

[0063] In one embodiment, the viewing device 101 may communicate over the network 108 with the server 110 to retrieve a portion of a database of visual references, corresponding three-dimensional virtual objects, and corresponding interactive features of the three-dimensional virtual objects.

[0064] Any one or more of the modules described herein may be implemented using hardware (e.g., a processor of a machine) or a combination of hardware and software. For example, any module described herein may configure a processor to perform the operations described herein for that module. Moreover, any two or more of these modules may be combined into a single module, and the functions described herein for a single module may be subdivided among multiple modules. Furthermore, according to various example embodiments, modules described herein as being implemented within a single machine, database, or device may be distributed across multiple machines, databases, or devices.

[0065] **FIG. 4A** is a block diagram illustrating modules (e.g., components) of the server 110. The server 110 includes a processor 402 and a database 410. The processor 402 may include a path bundle processing module 404 and a visualization module 406. The path bundle processing module 404 performs aggregation, filtering, and any non-visual processing (pattern recognition, predictive analysis) on the raw data paths. The visualization module 406 uses algorithms to combine the processed path bundles with the original models/assets to generate visually processed data and convert it to a report, visual display, or AR experience. Examples of visualization are illustrated in **FIGS. 16-19**. The visualization module 406 may generate a visualization on the AR content based on a user query (e.g., show the most viewed angles or areas of the AR content) and processed data. An example of the components of the visualization module 406 is described further with respect to **FIG. 4C**.

[0066] The database 410 may store a content dataset 412, virtual content dataset 414, and path bundle dataset 416. The content dataset 412 may store a primary content dataset and a contextual content dataset. The primary content dataset comprises a first set of images and corresponding virtual object models. A

captured image received from the viewing device 101 is not recognized in the content dataset 412, and the contextual content dataset is generated for the viewing device 101. The contextual content dataset may include a second set of images and corresponding virtual object models. The virtual content dataset 414 includes models of virtual objects to be generated upon receiving a notification associated with an image of a corresponding physical object. The path bundle dataset 416 includes visually processed data and/or raw data paths.

[0067] FIG. 4B is a block diagram illustrating an example embodiment of components in the path bundle processing module 404. The path bundle processing module 404 enables normalization and aggregation of spatial/sensor data from different sources and across multiple dimensions. Specifically, an analog spatial method is developed for basic aggregations such as average, median, sum, min, max, standard deviation, and variances that occur in most data processing applications. The same processing method allows for filtering out singular and aggregate data. For example, the path bundle processing module 404 may provide an answer in response to a query such as “Give me the average movement/scenario for the 10 seconds prior to event X (a sale/industrial accident/etc.) across all users of type Y or some other arbitrary segmentation. An extension of the data model may be created to represent aggregated data in a way that is consistent with the singular data paths. In other words, the aggregate data ends up being a subset or most common denominator of the multiple singular data paths.

[0068] The path bundle processing module 404 may include a normalization module 418, an aggregation module 420, and an analytics module 422.

[0069] The normalization module 418 may normalize the path bundle data packages. For example, all data path bundle packages may be normalized to eliminate the first and last 10% of the data path bundle. In another example, all path bundle data packages may be normalized to a common timing scheme independent of the path bundle’s location or device.

[0070] The aggregation module 420 may aggregate the normalized path bundle data packages. For example, all path bundle data packages may be

aggregated to combine all path bundle data packages for a particular device type into a single aggregate path bundle data package. In another example, all path bundle data packages may be statistically aggregated by combining path data bundle samples using common statistical methods such as an average or median of all sensor sample data for a particular bundle dimension.

[0071] In one embodiment, the normalization and the aggregation modules 418, 420 normalize and aggregate spatial and sensor data from multiple sources (e.g., from different sensors) across multiple dimensions (e.g., position, orientation, time) from the paths to filter singular and aggregate data. In another example embodiment, the normalized and aggregated path bundle data packages may be a subset or most common denominator of the multiple singular data paths. This normalization and aggregation reduces multiple data path bundles describing multiple sensor types into a single path bundle that represents the entire data set, but can still be manipulated, processed, and analyzed as a single path bundle data package. For example, if a particular process expects a path bundle data package as an input, but multiple path bundle data packages exist, the embodiment would be able to normalize and aggregate the multiple path bundle data packages into a single representative path bundle data package that can go through that particular process without further modification.

[0072] The analytics module 422 may perform analytics computation on the normalized and aggregated path bundle data packages. For example, the analytics module 422 may be used to recognize spatial patterns as follows:

[0073] The analytics module 422 may identify spatial patterns for accident and event prediction (e.g., 99% of a task's errors occur when operators are more than 30 cm from an instrument panel). In this example, the analytics data for the spatial sensors is correlated to process errors using session data and timing data found in the analytics contextual data information. Where an error is detected in the user session data, the spatial sensor data is selected for a particular period before and after the error occurred. Statistical analysis may be used to identify important correlations between error occurrences and spatial sensor data.

[0074] The analytics module 422 may also identify when similar patterns occur and accordingly warn operators (e.g., display a warning when an operator moves beyond 30 cm from an instrument panel). When an established pattern is identified, analytics data can then be checked in real time either on the user device or on an analytics server to identify whether that particular sensor data pattern has been matched. For example, sensor data used to generate the AR interaction can then be collected as analytics data and processed in real-time either on or off the user device. When a particular pattern is identified in the analytics data, a message or command can be sent to the user device to notify the user.

[0075] The analytics module 422 may also use weighting schemes to switch amongst sensors (e.g., using a temperature sensor's output to determine when infrared vs. visual light processing should be used). As AR interactions occur, the generated analytics data can be processed in real-time to identify whether any particular patterns are seen or conditions are met, and then send a command back to the device to change the particular sensors used or perform any other action.

[0076] The analytics module 422 may also identify user/operator focus points or loss-of-focus points to redirect them (e.g., when a user's spatial data indicates that they have not looked at a critical component for too long, visually direct them to the correct component). The inherent spatial and movement sensor data used to create an AR experience can be reported as analytics data. This sensor data can be processed to identify particular movement or orientation patterns, such as rapid pupil eye movement or repeated head nodding, by comparing the sensor data to known behaviors. When these behaviors are detected, a command can be sent back to the device, or any other relevant system, to initiate a process to remediate the users' undesired or unsafe behavior.

[0077] The analytics module 422 may also rank task complexity and calibrate user skill levels (e.g., using total eye movement or eye movement rate to determine how many steps or how many concurrent processes a user is performing). In another example, the analytics module 422 may determine that the user's behavior is unsafe. The inherent spatial and movement sensor data used to create an AR

experience can be reported as analytics data. This sensor data can be stored and analyzed to identify specific patterns to calibrate the tasks represented by the associated user activity. For example, the rate of pupil movement associated with the time between two known analytics events can be used to identify the complexity level of the task that occurs between those two events.

[0078] The analytics module 422 may also identify spatial movement-based gestures and interfaces (e.g., using spatial movements to capture and record previous or current movement, sensor, or visual activity so the user's hands (and concentration) are free). The inherent spatial and movement sensor data used to create an AR experience can be reported as analytics data. This analytics data can be analyzed outside of the AR process to identify patterns. This capability can be utilized by developing specific patterns that a user can recreate. When these patterns are identified in the analytics data, the processing system can send a command to the device and/or any other relevant system.

[0079] The analytics module 422 may also generate automatic tool/task/processing switching based on AR analytics (e.g., change camera processing from low-res to high-res when a user is spatially looking at a more granular gauge). The inherent spatial and movement sensor data used to create an AR experience can be reported as analytics data. This analytics data can be analyzed in conjunction with contextual user data to automatically modify the user experience. For example, if contextual user data indicates that a user prefers a particular color or style for an AR experience, then the analytics data that indicates that a user is initiating that experience can be matched with that user's data to provide a customized or specialized interface for the user.

[0080] In a last example, the analytics module 422 uses cohort analysis techniques to identify specific benefits/pain points of AR experiences (e.g., use spatial data to identify what model/asset component users are looking at before they purchase an item). The inherent spatial and movement sensor data used to create an AR experience can be reported as analytics data. This analytics data can then be

input into traditional analytics techniques by collecting, normalizing, aggregating, and formatting the data into traditional models.

[0081] In one embodiment, the analytics module 422 generates an extension of the data model to represent the normalized and aggregated path bundle data packages. If multiple users perform a task and each generates a single path bundle data package, the data model extension allows that the multiple path bundle data packages may be combined in such a way that a single path bundle data package is produced that represents all source path bundle data packages and can be manipulated, processed, and visualized similar to a normal path bundle data package.

[0082] For example, if a temperature sensor is being used by multiple users, the maximum temperature sample from each user may be combined to generate an overall maximum temperature bundle data package. This aggregated bundle data package may take the form of a standard path bundle data package, but contain a single data sample from each user instead of all data samples being related to the same user.

[0083] The analytics module 422 may determine whether predefined conditions are triggered based on the analysis. For example, the analytics module 422 may perform an analytics computation on the extension of the data model based on the trigger conditions and identify a particular spatial pattern (e.g., looking left to right, looking at a particular point for x seconds) based on the trigger conditions.

[0084] **FIG. 4C** is a block diagram illustrating an example embodiment of components of the visualization module 406. The visualization module 406 generates a visualization of the data resulting from the analytics module 422. For example, the visualization may include adjusting a shade, color, shape, or area of the AR content based on the analysis from the analytics module 422. For example, some areas of the AR content may be emphasized as a result of a query submitted to the analytics module 422. The visualization module 406 may include an aggregated visualization module 424 and a filtered visualization module 426.

[0085] The aggregated visualization module 424 may combine the aggregate data from the raw path bundles with AR three-dimensional models to generate a visualization of the processed aggregate data in conjunction (e.g., superimposed, overlaid, relative to) with the AR three-dimensional model. The visualization module 406 can send visualization data to a client or a viewing device. The visualization data may be used to render the overlay on the client or viewing device. In another embodiment, the visualization data may be already rendered on the server. An image of the rendered visualized data may be sent to the client or viewing device.

[0086] The filtered visualization module 426 may generate or receive dimensional parameters for analysis. The dimensional parameters may be used to filter data. The filtered visualization module 426 may filter and segment processed raw bundles based on the dimensional parameters. The filtered visualization module 426 then generates a visualization based on the filtered data. The filtered visualization data is communicated to a client or a viewing device. The filtered visualization data may be used to render the overlay on the client or viewing device. In another embodiment, the filtered visualization data may be already rendered on the server. An image of the rendered filtered visualized data may be sent to the client or viewing device.

[0087] **FIG. 5** is a diagram illustrating an example embodiment of a path bundle packaged data model 500. The data model 500 may include a data header 502 and a data payload 504. The data header 502 may include a contextual header 506, a path header 508, and a sensor header 510. The data payload 504 may include sampling data 512. The contextual header 506 may include, for example, data related to a user and a viewing device attached to the path. The data may change from path to path and may not be directly related to the data samples collected. The path header 508 includes data related to the corresponding path bundle. That data may change from each instance of a new path, but may not change for all the sample points within the path. The data from the path header 508 may also list a number and type of sensor collected. The sensor header 510 includes data related to each

specific sensor for a path and includes technical information about their collection such as the sample frequency or the threshold that triggers a non-frequency-based sample. The sampling data 512 includes, for example, a dynamically sized series of data samples that indicate which sensor is used, the time of the sample, the step number of the sample, whether it was frequency or threshold triggered, and so forth.

[0088] FIG. 6 is a diagram illustrating an example of a path bundle packaged data model. The contextual header 602 includes, for example, a device identifier, a session identifier, location information, and a device type. The path header 604 includes, for example, a path start time, a name and type of sensor, a total path duration, and a total path distance. The sensor header 606 includes, for each sensor, (for example sensor 1) a sensor name, a type of sensor, an initial calibration, a frequency, a threshold, and a number of samples. The sampling data 608 includes, for each sensor sample, a sample number, a frequency, a relative time, a duration percentage of the path, and a time percentage of the path.

[0089] FIG. 7 is a diagram illustrating another example of a path bundle packaged data model. The path bundle packaged data model includes examples of a contextual header 702, a path header 704, a sensor header 706, and sampling data 708.

[0090] The contextual header 702 may include, for example:

Device ID: ABCDE12345

Session ID: 23

Location: Los Angeles, CA, US

Device Type: Tablet

[0091] The path header 704 may include, for example:

Path Start: 2014-02-21T16:03:22.50

Sensor 1 – Camera, Sensor 2 – Camera, Sensor 3 – Temperature

Total Duration: 60 s

Total Path – 25 cm

[0092] The sensor header 706 may include, for example:

Sensor 1

Left Eye

Camera

[0.2,0.1,0.1]

5 s

5 deg

12 samples

[0093] The sampling data 708 may include, for example:

Left Eye

Sample 1 (F)

16:05:15

8% through Time

20% through Path

X,Y,Z

[0094] The path bundle packaged data model may be linked to an event flow 709 by session identifier and time. For example, at operation 710, a session starts when a user turns the device on or resumes the device from a sleep/pause mode. At operation 712, the process starts when the user, or an automated process, indicates that a particular task or process has begun, such as a process to check a series of gauges. At operation 714, the user requests information about a particular step in the process. At operation 716, a hazard is identified. For example, the device identifies that a temperature gauge has risen above a dangerous threshold using computer vision techniques. At operation 718, the user is presented with steps to remediate the risk by lowering the temperature in question, recalibrating the gauge,

and so forth. At operation 720, the user or an automated process indicates that the task or process has been completed. At operation 722, the session ends when the user turns their device off or puts the device into a sleep/pause mode.

[0095] **FIG. 8** is a diagram illustrating an example of a path bundle streaming data model. The path bundle streaming data model includes a contextual header 802, a path header 804, a sensor header 806, and sampling data 808. The streaming model is a subset of the packaged model that removes any data points that would require information generated after the data point is generated. For example, the percentage of path length cannot be calculated for individual points until the total path length is determined.

[0096] **FIG. 9A** is a ladder diagram illustrating an example embodiment of a method for spatial data collection and processing. At operation 902, the viewing device 101 generates an AR content based on a physical object. At operation 904, the viewing device 101 accesses sensor data from the viewing device 101. At operation 906, the viewing device 101 aggregates sensor data using a data model to generate raw path bundles. At operation 908, the viewing device 101 communicates the raw path bundles to the server 110 for storage and processing. The server 110 stores raw path bundles at operation 910. The server 110 processes the raw path bundles at operation 912 using, for example, the path bundle processing module 404. The server 110 generates a visualization based on the processed raw path bundles at operation 914.

[0097] **FIG. 9B** is a ladder diagram illustrating another example embodiment of an operation of spatial data visualization. At operation 920, the server 110 combines processed aggregate data the raw path bundles with an AR 3D model. At operation 922, the server 110 generates a visualization based on the processed aggregate data. The server 110 transmits the visualization of the processed aggregate data with the AR 3D model at operation 924 to a client device 901 or a viewing device 101. At operation 926, the client device 901 or viewing device 101 renders the visualization of processed aggregate data relative to the AR 3D model. At operation 928, the viewing device 101 synchronizes the visualization based on

the position and orientation of the viewing device 101. In another example, the client device 901 may view the visualization “live” based the position and orientation of the viewing device 101.

[0098] **FIG. 9C** is a ladder diagram illustrating another example embodiment of an operation of spatial data visualization. At operation 930, the server 110 receives dimensional parameters for analysis. For example, the dimensional parameters may be most viewed areas, longest dwelling time, most common viewing paths or trajectories, and so forth. At operation 932, the server 110 filters and segments the processed raw path bundles based on the dimensional parameters 932. For example, only processed raw path bundles data corresponding to viewing time greater than 3 seconds may be kept for further analysis. At operation 934, the server 110 generates a visualization based on the filtered and segmented processed aggregate data. At operation 936, the server 110 transmits the visualization based on the filtered data relative to the AR 3D model to a client device 901 or the viewing device 101. At operation 938, the client device 901 or viewing device 101 renders the visualization of the filtered data relative to the AR 3D model. At operation 940, the viewing device 101 synchronizes the visualization with physical objects in a scene based on the position and orientation of the viewing device 101. In another example, the client device 901 may view the visualization “live” based the position and orientation of the viewing device 101.

[0099] **FIG. 10** is a flowchart illustrating an example method for spatial data collection at a viewing device. At operation 1002, the viewing device 101 accesses sensor data. At operation 1004, the viewing device 101 generates an AR content. At operation 1006, the viewing device 101 generates raw path bundles from the sensor data using a data model. At operation 1008, the viewing device 101 sends the raw path bundles data using the data model to the server 110 for processing.

[00100] **FIG. 11** is a flowchart illustrating an example method for spatial data processing at a server connected to a viewing device. At operation 1102, the path bundle processing module 404 of the server 110 normalizes spatial and sensor data across multiple dimensions. At operation 1104, the path bundle processing module

404 aggregates the normalized spatial and sensor data. At operation 1106, the path bundle processing module 404 generates an extension of the data model to represent the aggregated data. At operation 1108, the path bundle processing module 404 accesses trigger conditions or queries. At operation 1110, the path bundle processing module 404 performs analysis on the extension of the data model for trigger conditions and queries. At operation 1112, the path bundle processing module 404 identifies spatial patterns based on conditions and queries.

[00101] FIG. 12 is a flowchart illustrating an example method for generating aggregate data visualization at a server. At operation 1202, processed aggregate data from raw path bundles are combined with AR three-dimensional models. At operation 1204, a visualization of the processed aggregate data is generated in conjunction with the AR three-dimensional model. At operation 1206, the generated visualization of the processed aggregated data with the AR three-dimensional model is sent to a client or a viewing device. In one example embodiment, the aggregated visualization module 424 performs operations 1202, 1204, and 1206.

[00102] FIG. 13 is a flowchart illustrating an example method for generating filtered data visualization at a server. At operation 1302, the server receives a query or dimensional parameters for analysis. At operation 1304, the server may filter and segment processed raw bundles based on the dimensional parameters. At operation 1306, a visualization based on the filtered data is generated. At operation 1308, the visualization is communicated to a client or a viewing device. In one example embodiment, the filtered visualization module 426 performs operations 1302, 1304, 1306, and 1308.

[00103] FIG. 16 is a diagram illustrating an example of visualization. The virtual object 1602 includes a three-dimensional model of a valve. A heatmap with shaded areas 1604 may identify areas with most views.

[00104] FIG. 17 is a diagram illustrating another example of visualization. Dwelling areas 1702 are identified on the three-dimensional model of the object. Dwelling areas may include areas where the user has stopped rotation of the three-

dimensional model to view the three-dimensional model from a particular angle or perspective. The dwelling time may be a predefined time (e.g., more than 4 seconds). A most common viewed trajectory path 1704 may be identified. The trajectory path shows a path of how the user manipulates or interacts with the virtual object.

[00105] FIG. 18 is a diagram illustrating another example of visualization. An image of the real world object 1804 may be displayed. AR content 1802, 1806 may include instructions on how to operate the real world object 1804 (e.g., which button to press first).

[00106] FIG. 19 is a diagram illustrating another example of visualization. A three-dimensional model of a heart 1902 is generated. A trajectory path or viewing paths of the heart 1902 from multiple viewing devices may be aggregated and represented with lines 1904.

MODULES, COMPONENTS AND LOGIC

[00107] Certain embodiments are described herein as including logic or a number of components, modules, or mechanisms. Modules may constitute either software modules (e.g., code embodied on a machine-readable medium or in a transmission signal) or hardware modules. A hardware module is a tangible unit capable of performing certain operations and may be configured or arranged in a certain manner. In example embodiments, one or more computer systems (e.g., a standalone, client, or server computer system) or one or more hardware modules of a computer system (e.g., a processor or a group of processors) may be configured by software (e.g., an application or application portion) as a hardware module that operates to perform certain operations as described herein.

[00108] In various embodiments, a hardware module may be implemented mechanically or electronically. For example, a hardware module may comprise dedicated circuitry or logic that is permanently configured (e.g., as a special-purpose processor, such as a field programmable gate array (FPGA) or an application-specific integrated circuit (ASIC)) to perform certain operations. A hardware

module may also comprise programmable logic or circuitry (e.g., as encompassed within a general-purpose processor or other programmable processor) that is temporarily configured by software to perform certain operations. It will be appreciated that the decision to implement a hardware module mechanically, in dedicated and permanently configured circuitry, or in temporarily configured circuitry (e.g., configured by software) may be driven by cost and time considerations.

[00109] Accordingly, the term “hardware module” should be understood to encompass a tangible entity, be that an entity that is physically constructed, permanently configured (e.g., hardwired) or temporarily configured (e.g., programmed) to operate in a certain manner and/or to perform certain operations described herein. Considering embodiments in which hardware modules are temporarily configured (e.g., programmed), each of the hardware modules need not be configured or instantiated at any one instance in time. For example, where the hardware modules comprise a general-purpose processor configured using software, the general-purpose processor may be configured as respective different hardware modules at different times. Software may accordingly configure a processor, for example, to constitute a particular hardware module at one instance of time and to constitute a different hardware module at a different instance of time.

[00110] Hardware modules can provide information to, and receive information from, other hardware modules. Accordingly, the described hardware modules may be regarded as being communicatively coupled. Where multiple of such hardware modules exist contemporaneously, communications may be achieved through signal transmission (e.g., over appropriate circuits and buses) that connect the hardware modules. In embodiments in which multiple hardware modules are configured or instantiated at different times, communications between such hardware modules may be achieved, for example, through the storage and retrieval of information in memory structures to which the multiple hardware modules have access. For example, one hardware module may perform an operation and store the output of that operation in a memory device to which it is communicatively coupled. A further hardware module may then, at a later time, access the memory device to

retrieve and process the stored output. Hardware modules may also initiate communications with input or output devices and can operate on a resource (e.g., a collection of information).

[00111] The various operations of example methods described herein may be performed, at least partially, by one or more processors that are temporarily configured (e.g., by software) or permanently configured to perform the relevant operations. Whether temporarily or permanently configured, such processors may constitute processor-implemented modules that operate to perform one or more operations or functions. The modules referred to herein may, in some example embodiments, comprise processor-implemented modules.

[00112] Similarly, the methods described herein may be at least partially processor-implemented. For example, at least some of the operations of a method may be performed by one or more processors or processor-implemented modules. The performance of certain of the operations may be distributed among the one or more processors, not only residing within a single machine, but deployed across a number of machines. In some example embodiments, the processor or processors may be located in a single location (e.g., within a home environment, an office environment or as a server farm), while in other embodiments the processors may be distributed across a number of locations.

[00113] The one or more processors may also operate to support performance of the relevant operations in a “cloud computing” environment or as a “software as a service” (SaaS). For example, at least some of the operations may be performed by a group of computers (as examples of machines including processors), these operations being accessible via a network and via one or more appropriate interfaces (e.g., APIs).

ELECTRONIC APPARATUS AND SYSTEM

[00114] Example embodiments may be implemented in digital electronic circuitry, or in computer hardware, firmware, software, or in combinations of them. Example embodiments may be implemented using a computer program product, e.g., a computer program tangibly embodied in an information carrier, e.g., in a

machine-readable medium for execution by, or to control the operation of, data processing apparatus, e.g., a programmable processor, a computer, or multiple computers.

[00115] A computer program can be written in any form of programming language, including compiled or interpreted languages, and it can be deployed in any form, including as a stand-alone program or as a module, subroutine, or other unit suitable for use in a computing environment. A computer program can be deployed to be executed on one computer or on multiple computers at one site or distributed across multiple sites and interconnected by a communication network.

[00116] In example embodiments, operations may be performed by one or more programmable processors executing a computer program to perform functions by operating on input data and generating output. Method operations can also be performed by, and apparatus of example embodiments may be implemented as, special purpose logic circuitry (e.g., a FPGA or an ASIC).

[00117] A computing system can include clients and servers. A client and server are generally remote from each other and typically interact through a communication network. The relationship of client and server arises by virtue of computer programs running on the respective computers and having a client-server relationship to each other. In embodiments deploying a programmable computing system, it will be appreciated that both hardware and software architectures merit consideration. Specifically, it will be appreciated that the choice of whether to implement certain functionality in permanently configured hardware (e.g., an ASIC), in temporarily configured hardware (e.g., a combination of software and a programmable processor), or a combination of permanently and temporarily configured hardware may be a design choice. Below are set out hardware (e.g., machine) and software architectures that may be deployed, in various example embodiments.

EXAMPLE MACHINE ARCHITECTURE AND MACHINE-READABLE MEDIUM

[00118] FIG. 14 is a block diagram of a machine in the example form of a computer system 1400 within which instructions 1424 for causing the machine to perform any one or more of the methodologies discussed herein may be executed. In alternative embodiments, the machine operates as a standalone device or may be connected (e.g., networked) to other machines. In a networked deployment, the machine may operate in the capacity of a server or a client machine in a server-client network environment, or as a peer machine in a peer-to-peer (or distributed) network environment. The machine may be a personal computer (PC), a tablet PC, a set-top box (STB), a Personal Digital Assistant (PDA), a cellular telephone, a web appliance, a network router, switch or bridge, or any machine capable of executing instructions (sequential or otherwise) that specify actions to be taken by that machine. Further, while only a single machine is illustrated, the term “machine” shall also be taken to include any collection of machines that individually or jointly execute a set (or multiple sets) of instructions to perform any one or more of the methodologies discussed herein.

[00119] The example computer system 1400 includes a processor 1402 (e.g., a central processing unit (CPU), a graphics processing unit (GPU), or both), a main memory 1404 and a static memory 1406, which communicate with each other via a bus 1408. The computer system 1400 may further include a video display unit 1410 (e.g., a liquid crystal display (LCD) or a cathode ray tube (CRT)). The computer system 1400 also includes an alphanumeric input device 1412 (e.g., a keyboard), a user interface (UI) navigation (or cursor control) device 1414 (e.g., a mouse), a disk drive unit 1416, a signal generation device 1418 (e.g., a speaker), and a network interface device 1420.

MACHINE-READABLE MEDIUM

[00120] The disk drive unit 1416 includes a machine-readable medium 1422 on which is stored one or more sets of data structures and instructions 1424 (e.g., software) embodying or utilized by any one or more of the methodologies or

functions described herein. The instructions 1424 may also reside, completely or at least partially, within the main memory 1404 and/or within the processor 1402 during execution thereof by the computer system 1400, with the main memory 1404 and the processor 1402 also constituting machine-readable media. The instructions 1424 may also reside, completely or at least partially, within the static memory 1406.

[00121] While the machine-readable medium 1422 is shown in an example embodiment to be a single medium, the term "machine-readable medium" may include a single medium or multiple media (e.g., a centralized or distributed database, and/or associated caches and servers) that store the one or more instructions 1424 or data structures. The term "machine-readable medium" shall also be taken to include any tangible medium that is capable of storing, encoding or carrying instructions 1424 for execution by the machine and that cause the machine to perform any one or more of the methodologies of the present embodiments, or that is capable of storing, encoding or carrying data structures utilized by or associated with such instructions. The term "machine-readable medium" shall accordingly be taken to include, but not be limited to, solid-state memories, and optical and magnetic media. Specific examples of machine-readable media include non-volatile memory, including by way of example semiconductor memory devices (e.g., Erasable Programmable Read-Only Memory (EPROM), Electrically Erasable Programmable Read-Only Memory (EEPROM), and flash memory devices); magnetic disks such as internal hard disks and removable disks; magneto-optical disks; and compact disc-read-only memory (CD-ROM) and digital versatile disc (or digital video disc) read-only memory (DVD-ROM) disks.

TRANSMISSION MEDIUM

[00122] The instructions 1424 may further be transmitted or received over a communications network 1426 using a transmission medium. The instructions 1424 may be transmitted using the network interface device 1420 and any one of a number of well-known transfer protocols (e.g., HTTP). Examples of communication networks include a LAN, a WAN, the Internet, mobile telephone networks, POTS

networks, and wireless data networks (e.g., WiFi and WiMax networks). The term "transmission medium" shall be taken to include any intangible medium capable of storing, encoding, or carrying instructions 1424 for execution by the machine, and includes digital or analog communications signals or other intangible media to facilitate communication of such software.

EXAMPLE MOBILE DEVICE

[00123] **FIG. 15** is a block diagram illustrating a mobile device 1500, according to an example embodiment. The mobile device 1500 may include a processor 1502. The processor 1502 may be any of a variety of different types of commercially available processors 1502 suitable for mobile devices 1500 (for example, an XScale architecture microprocessor, a microprocessor without interlocked pipeline stages (MIPS) architecture processor, or another type of processor 1502). A memory 1504, such as a random access memory (RAM), a flash memory, or other type of memory, is typically accessible to the processor 1502. The memory 1504 may be adapted to store an operating system (OS) 1506, as well as application programs 1508, such as a mobile location enabled application that may provide location-based services (LBSs) to a user. The processor 1502 may be coupled, either directly or via appropriate intermediary hardware, to a display 1510 and to one or more input/output (I/O) devices 1512, such as a keypad, a touch panel sensor, a microphone, and the like. Similarly, in some embodiments, the processor 1502 may be coupled to a transceiver 1514 that interfaces with an antenna 1516. The transceiver 1514 may be configured to both transmit and receive cellular network signals, wireless data signals, or other types of signals via the antenna 1516, depending on the nature of the mobile device 1500. Further, in some configurations, a GPS receiver 1518 may also make use of the antenna 1516 to receive GPS signals.

[00124] Although an embodiment has been described with reference to specific example embodiments, it will be evident that various modifications and changes may be made to these embodiments without departing from the scope of the

present disclosure. Accordingly, the specification and drawings are to be regarded in an illustrative rather than a restrictive sense. The accompanying drawings that form a part hereof, show by way of illustration, and not of limitation, specific embodiments in which the subject matter may be practiced. The embodiments illustrated are described in sufficient detail to enable those skilled in the art to practice the teachings disclosed herein. Other embodiments may be utilized and derived therefrom, such that structural and logical substitutions and changes may be made without departing from the scope of this disclosure. This Detailed Description, therefore, is not to be taken in a limiting sense, and the scope of various embodiments is defined only by the appended claims, along with the full range of equivalents to which such claims are entitled.

[00125] Such embodiments of the inventive subject matter may be referred to herein, individually and/or collectively, by the term “invention” merely for convenience and without intending to voluntarily limit the scope of this application to any single invention or inventive concept if more than one is in fact disclosed. Thus, although specific embodiments have been illustrated and described herein, it should be appreciated that any arrangement calculated to achieve the same purpose may be substituted for the specific embodiments shown. This disclosure is intended to cover any and all adaptations or variations of various embodiments. Combinations of the above embodiments, and other embodiments not specifically described herein, will be apparent to those of skill in the art upon reviewing the above description.

[00126] The Abstract of the Disclosure is provided to allow the reader to quickly ascertain the nature of the technical disclosure. It is submitted with the understanding that it will not be used to interpret or limit the scope or meaning of the claims. In addition, in the foregoing Detailed Description, it can be seen that various features are grouped together in a single embodiment for the purpose of streamlining the disclosure. This method of disclosure is not to be interpreted as reflecting an intention that the claimed embodiments require more features than are expressly recited in each claim. Rather, as the following claims reflect, inventive subject matter lies in less than all features of a single disclosed embodiment. Thus

the following claims are hereby incorporated into the Detailed Description, with each claim standing on its own as a separate embodiment.

CLAIMS

What is claimed is:

1. A server comprising:
 - a hardware processor comprising an augmented reality application, the augmented reality application including:
 - an analytics module configured to perform an analytics computation of users' interactions with an augmented reality content based on a physical object captured by a viewing device, the analytics computation comprising a computation of geometric paths of the users' interactions with the augmented reality content; and
 - a visualization module configured to cause a display of a visualization of the analytics computation from the users' interactions with the augmented reality content.
2. The server of claim 1, wherein the display includes a heatmap identifying areas with relatively higher number of users' interactions with the augmented reality content.
3. The server of claim 1, wherein the display includes trajectory paths of the users' interactions with the augmented reality content, the trajectory paths identifying rotations and movements of the augmented reality content caused by the users' interactions.
4. The server of claim 3, wherein the display includes an identification of most common trajectory paths of the users' interactions with the augmented reality content.
5. The server of claim 1, wherein the geometric paths of the users' interactions comprise a geometric trajectory based on a dwelling time exceeding a threshold for a view of the augmented reality content.

6. The server of claim 1, further comprising:
- a path bundle processing module configured to access and process path bundle data packages received from the viewing device, the path bundle data packages describing a user's interaction of the viewing device with the augmented reality content based on a physical object captured by the viewing device, the path bundle data packages generated based on sensor data using a data model comprising a data header and a data payload, the data header comprising a contextual header having data identifying the viewing device and a user of the viewing device, a path header having data identifying a path of the user interaction with the augmented reality content, and a sensor header having data identifying a plurality of sensors, the data payload comprising dynamically sized sampling data from the sensor data, the path bundle processing module comprising a normalization module;
 - a normalization module configured to normalize the path bundle data packages;
 - an aggregation module configured to aggregate the normalized path bundle data packages; and
 - the analytics module configured to perform the analytics computation on the normalized and aggregated path bundle data packages.
7. The server of claim 6, wherein the analytics module is configured to generate an extension of the data model to represent the normalized and aggregated path bundle data packages, to access trigger conditions, to perform the analytics computation on the extension of the data model based on the trigger conditions, and to identify a spatial pattern based on the trigger conditions.
8. The server of claim 7, wherein the normalization and the aggregation modules are configured to normalize and aggregate spatial and sensor data from multiple sources across multiple dimensions from the path to filter singular and aggregate data.
9. The server of claim 6, wherein the analytics module is configured to:

identify spatial patterns for accidents and event predictions;
recognize similar patterns and warn operators of the viewing device;
assign weighting schemes for switching amongst sensors of the viewing device;
identify user focus points and user loss of focus and redirect the user;
rank task complexity and calibrate user skill levels based on the normalized and aggregated path bundle data packages; and
identify spatial movement-based gestures and interfaces based on the normalized and aggregated path bundle data packages.

10. The server of claim 6, wherein the sensor data is related to a position and an orientation of the viewing device over time, the plurality of sensors comprising optical sensors and inertia sensors,
wherein the contextual header comprises a viewing device identifier, a session identifier, a physical location, and a viewing device type,
wherein the path header comprises a path start time, a path end time, a type of sensor identifier for each corresponding sensor, a total duration of the path, and a total distance of the path,
wherein the sensor header comprises, for each sensor, a sensor identifier, a sensor position identifier, three-dimensional position data, orientation data, and a number of data samples,
wherein the dynamically sized sampling data comprises a sensor identifier, a data sample number, a relative time, a duration percentage through the path, and a time percentage through the path.

11. A method comprising:
 - performing, using a hardware processor of a machine, an analytics computation of users' interactions with an augmented reality content based on a physical object captured by a viewing device, the analytics computation comprising a computation of geometric paths of the users' interactions with the augmented reality content; and
 - causing a display of a visualization of the analytics computation from the users' interactions with the augmented reality content.
12. The method of claim 11, wherein the display includes a heatmap identifying areas with relatively higher number of users' interactions with the augmented reality content.
13. The method of claim 11, wherein the display includes trajectory paths of the users' interactions with the augmented reality content, the trajectory paths identifying rotations and movements of the augmented reality content caused by the users' interactions.
14. The method of claim 13, wherein the display includes an identification of most common trajectory paths of the users' interactions with the augmented reality content.
15. The method of claim 11, wherein the geometric paths of the users' interactions comprise a geometric trajectory based on a dwelling time exceeding a threshold for a view of the augmented reality content.
16. The method of claim 11, further comprising:
 - accessing and processing path bundle data packages received from the viewing device, the path bundle data packages describing a user interaction of the viewing device with the augmented reality content based on a physical object captured by the viewing device, the path bundle data packages generated based on

sensor data using a data model comprising a data header and a data payload, the data header comprising a contextual header having data identifying the viewing device and a user of the viewing device, a path header having data identifying a path of the user interaction with the augmented reality content, and a sensor header having data identifying a plurality of sensors, the data payload comprising dynamically sized sampling data from the sensor data, the path bundle processing module comprising a normalization module;

- normalizing the path bundle data packages;
- aggregating the normalized path bundle data packages; and
- performing the analytics computation on the normalized and aggregated path bundle data packages.

17. The method of claim 16, further comprising:

- generating an extension of the data model to represent the normalized and aggregated path bundle data packages, to access trigger conditions, to perform the analytics computation on the extension of the data model based on the trigger conditions, and to identify a spatial pattern based on the trigger conditions; and
- normalizing and aggregating spatial and sensor data from multiple sources across multiple dimensions from the path to filter singular and aggregate data.

18. The method of claim 16, further comprising:

- identifying spatial patterns for accidents and event predictions;
- recognizing similar patterns and warning operators of the viewing device;
- assigning weighting schemes for switching amongst sensors of the viewing device;
- identifying user focus points and user loss of focus and redirecting the user;
- ranking task complexity and calibrating user skill levels based on the normalized and aggregated path bundle data packages; and
- identifying spatial movement-based gestures and interfaces based on the normalized and aggregated path bundle data packages.

19. The method of claim 16, wherein the sensor data is related to a position and an orientation of the viewing device over time, the plurality of sensors comprising optical sensors and inertia sensors,

wherein the contextual header comprises a viewing device identifier, a session identifier, a physical location, and a viewing device type,

wherein the path header comprises a path start time, a path end time, a type of sensor identifier for each corresponding sensor, a total duration of the path, and a total distance of the path,

wherein the sensor header comprises, for each sensor, a sensor identifier, a sensor position identifier, three-dimensional position data, orientation data, and a number of data samples,

wherein the dynamically sized sampling data comprises a sensor identifier, a data sample number, a relative time, a duration percentage through the path, and a time percentage through the path.

20. A non-transitory machine-readable medium comprising instructions that, when executed by one or more processors of a machine, cause the machine to perform operations comprising:

performing an analytics computation of users' interactions with an augmented reality content based on a physical object captured by a viewing device, the analytics computation comprising a computation of geometric paths of the users' interactions with the augmented reality content; and

causing a display of a visualization of the analytics computation from the users' interactions with the augmented reality content.

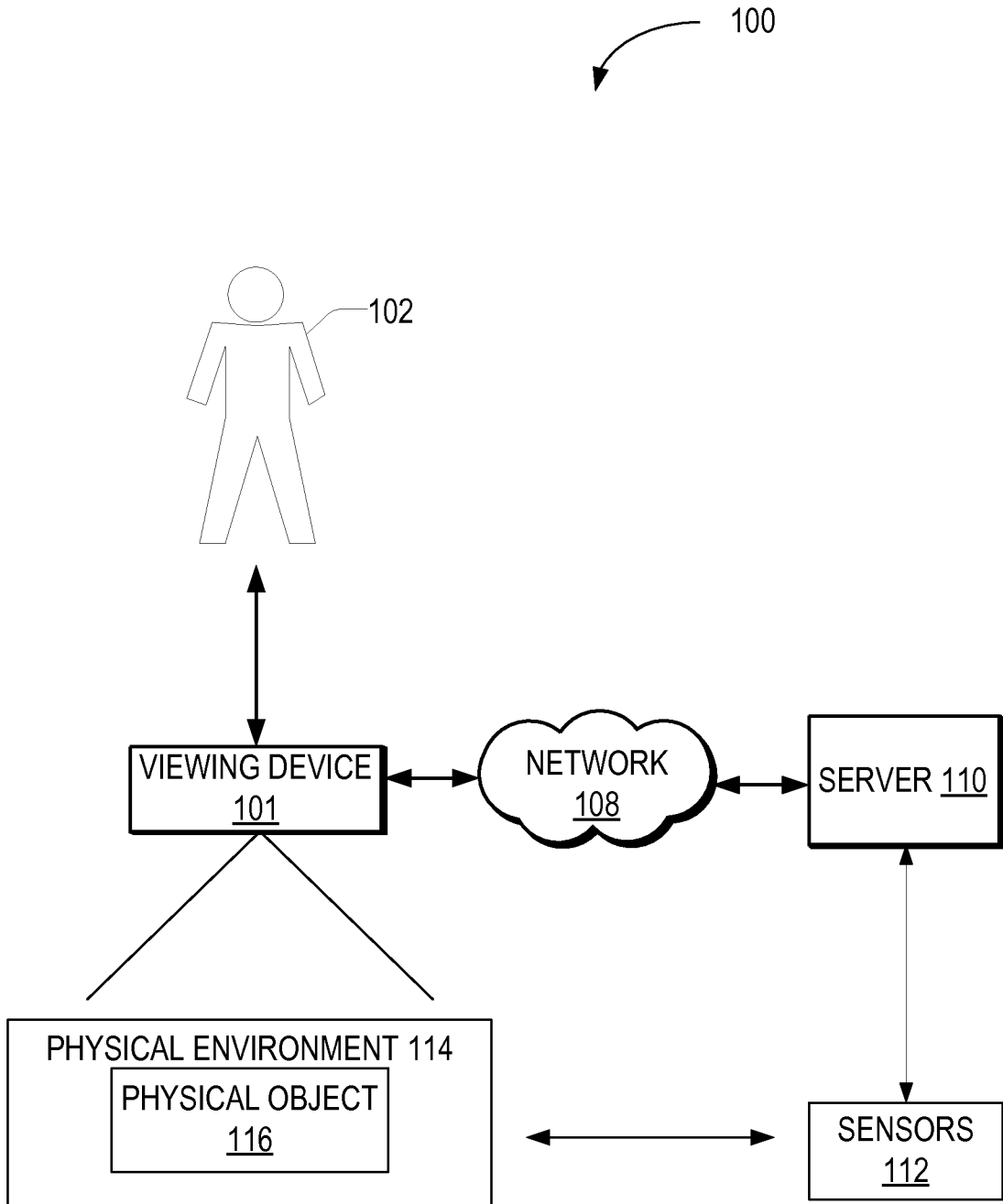

FIG. 1

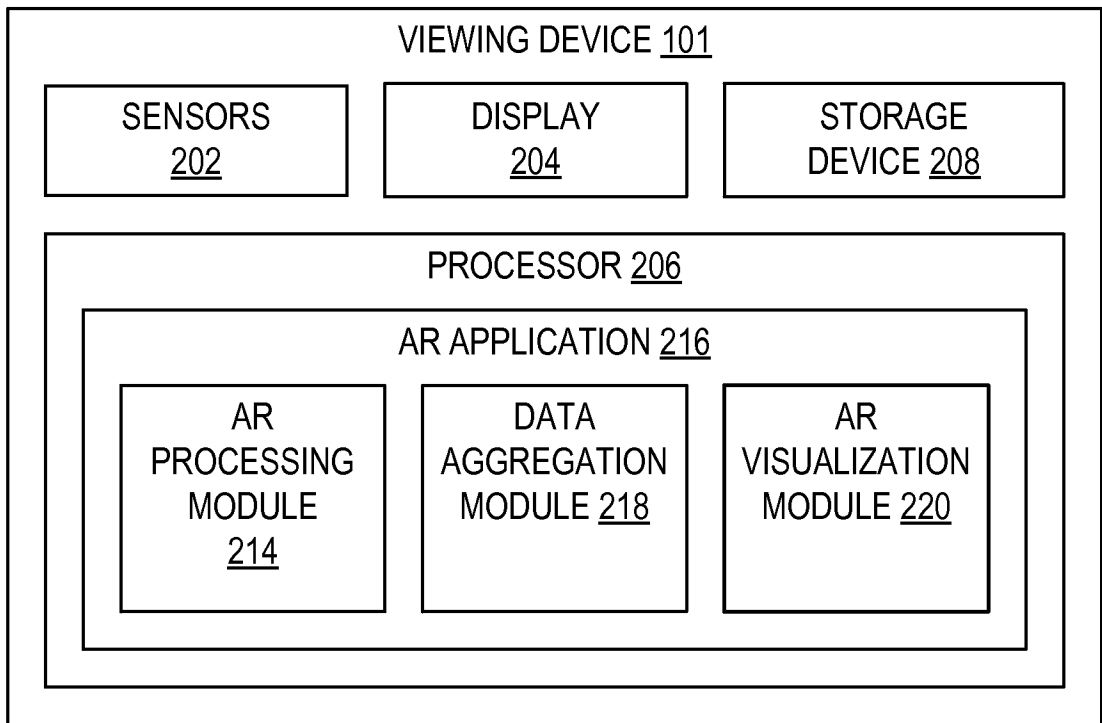

FIG. 2

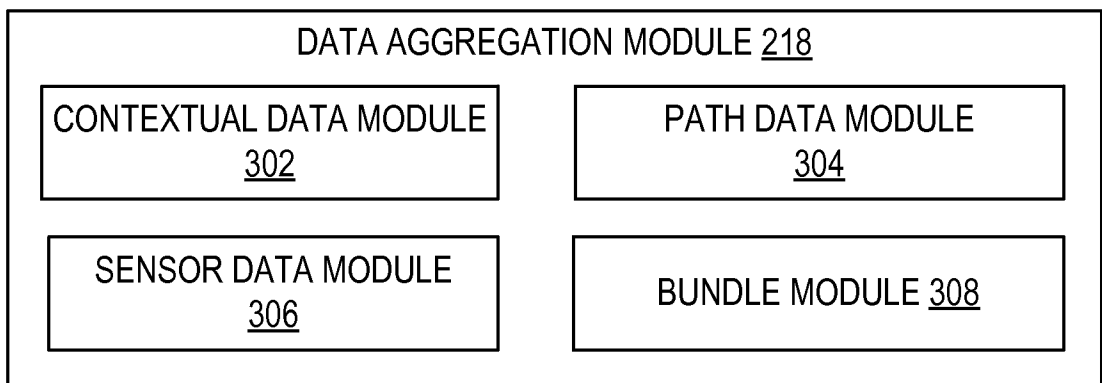

FIG. 3

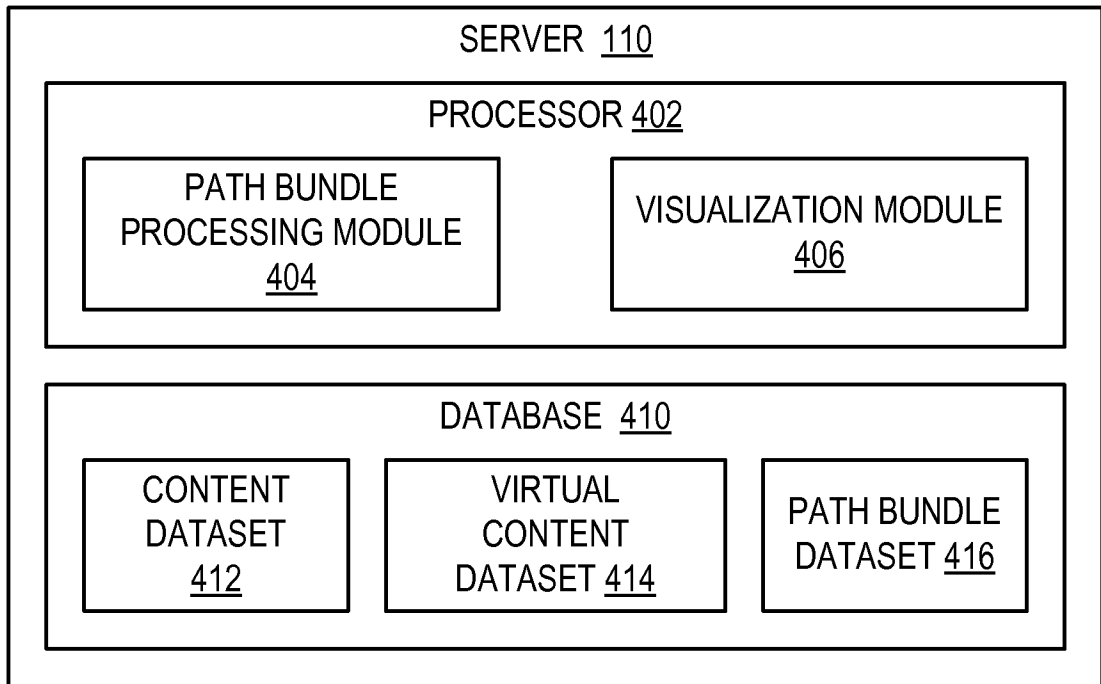

FIG. 4A

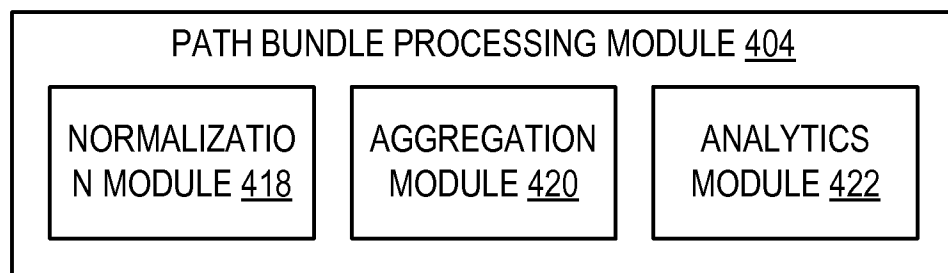

FIG. 4B

4/21

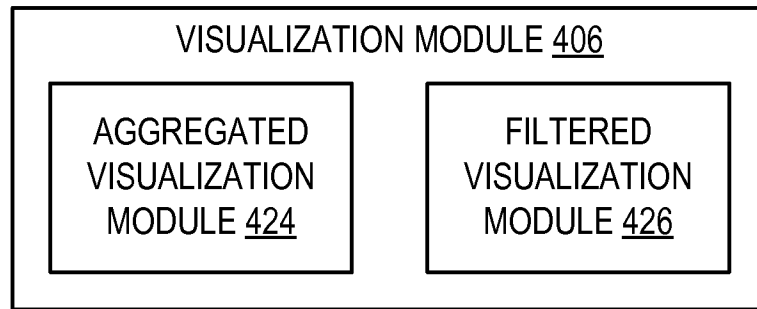

FIG. 4C

<p>CONTEXTUAL HEADER</p>	<p>THE CONTEXTUAL HEADER CONTAINS DATA RELATED TO THE USER AND DEVICE ATTACHED TO THIS PATH. IT MAY CHANGE FROM PATH TO PATH, BUT IS NOT DIRECTLY RELATED TO THE DATA SAMPLES COLLECTED.</p>
<p>PATH HEADER</p>	<p>THE PATH HEADER CONTAINS DATA RELATED TO THAT SPECIFIC PATH BUNDLE. THIS WILL CHANGE FROM EACH INSTANCE OF A NEW PATH, BUT WILL NOT CHANGE FOR ALL OF THE SAMPLE POINTS WITHIN THE PATH. THE PATH HEADER WILL ALSO LIST THE NUMBER AND TYPE OF SENSORS COLLECTED (WHICH WILL BE DESCRIBED BY THE SENSOR HEADER)</p>
<p>SENSOR HEADER</p>	<p>THE SENSOR HEADER DESCRIBES EACH SPECIFIC SENSOR THAT WILL BE COLLECTED IN THIS PATH, AND ALSO PROVIDES TECHNICAL INFORMATION ABOUT THEIR COLLECTION SUCH AS THE SAMPLE FREQUENCY OR THE THRESHOLD THAT WILL TRIGGER A NON-FREQUENCY-BASED SAMPLE.</p>
<p>SAMPLING DATA</p>	<p>THE SAMPLING DATA IS A DYNAMICALLY SIZED SERIES OF DATA SAMPLES THAT INDICATE WHICH SENSOR IS USED, THE TIME OF THE SAMPLE, THE STEP # OF THE SAMPLE, WHETHER IT WAS FREQUENCY OR THRESHOLD TRIGGERED, ETC.</p>

502 → 506
DATA
HEADER

508

510

504 → 512
DATA
PAYLOAD

FIG. 5

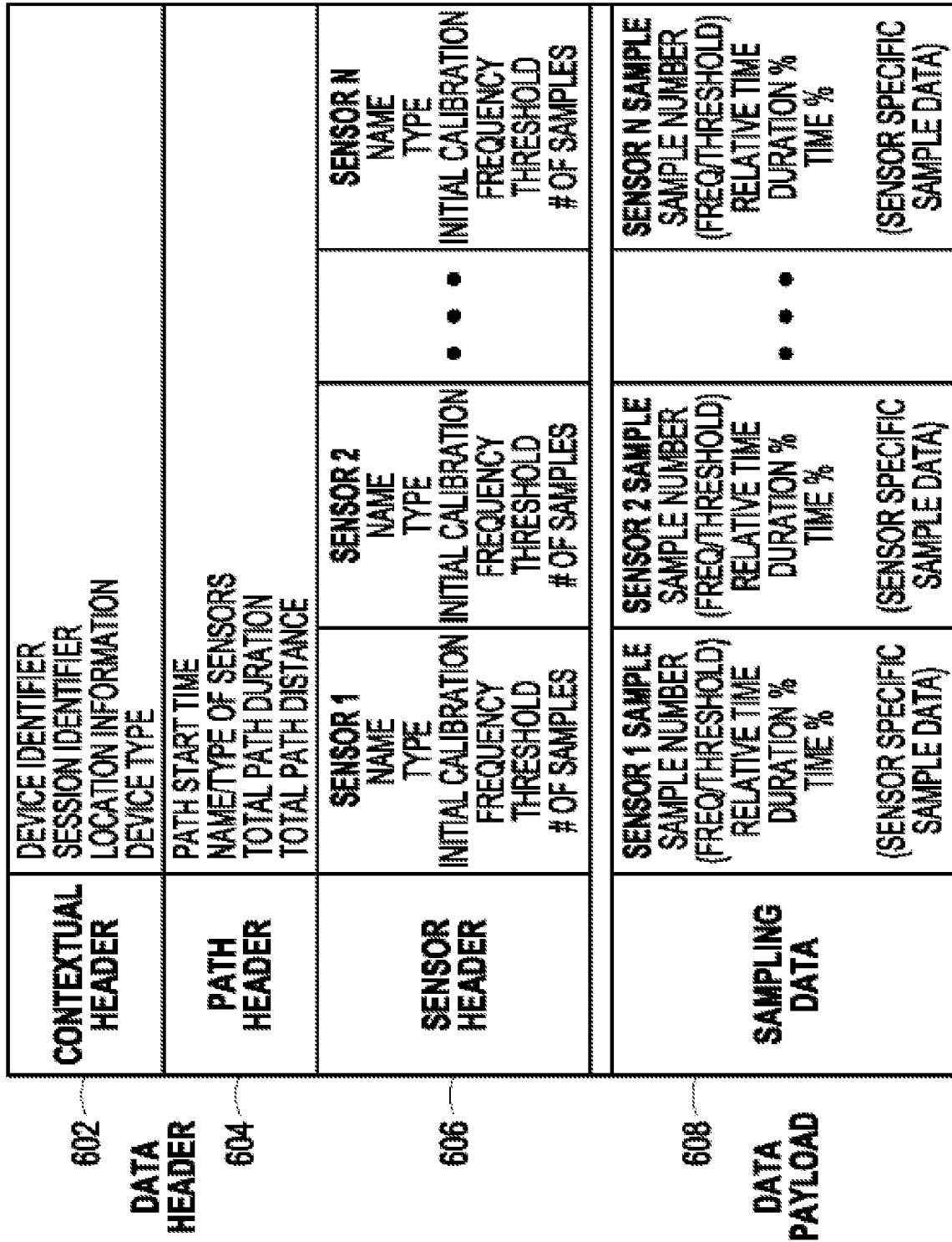
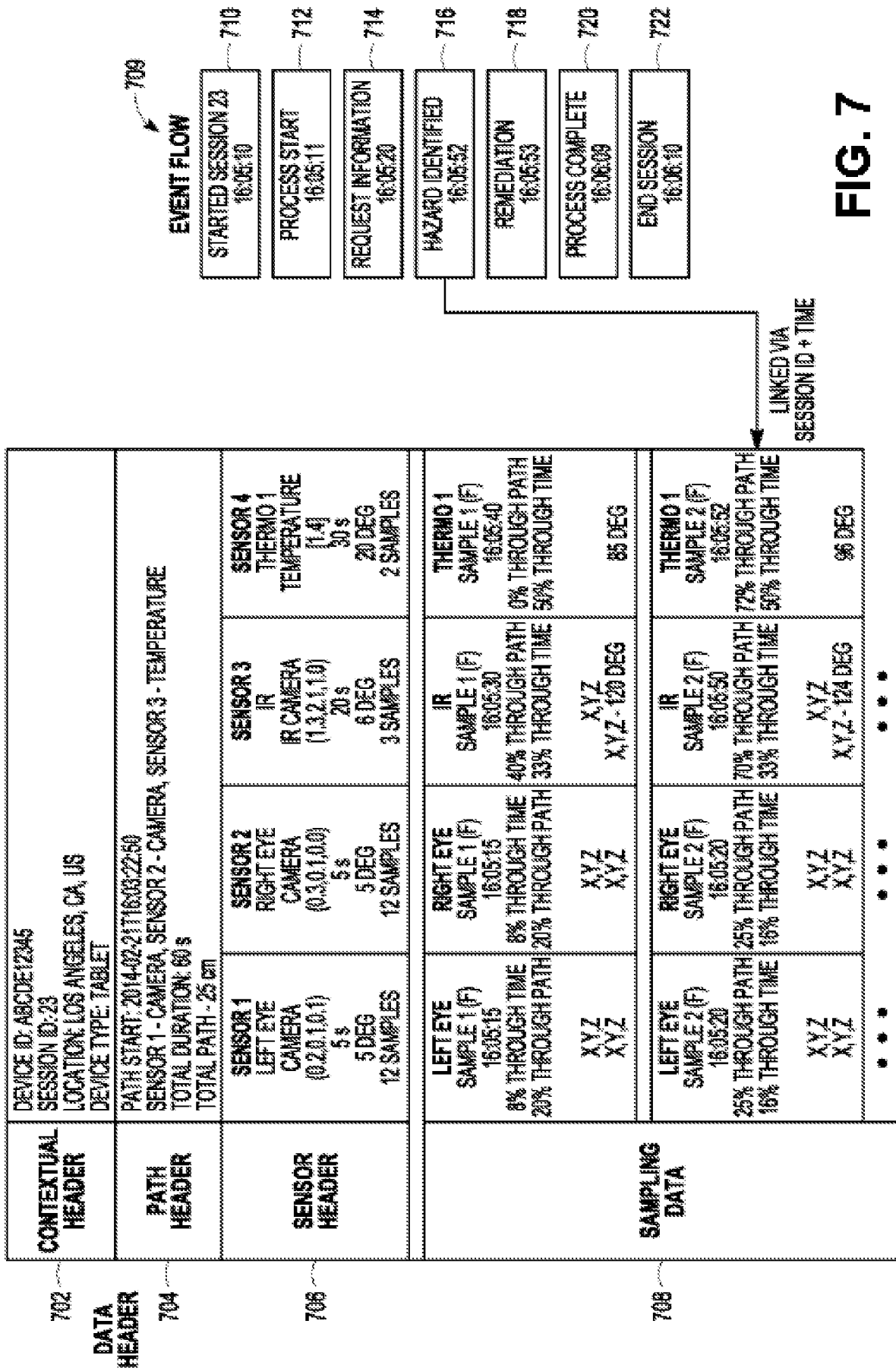

FIG. 6

7/21



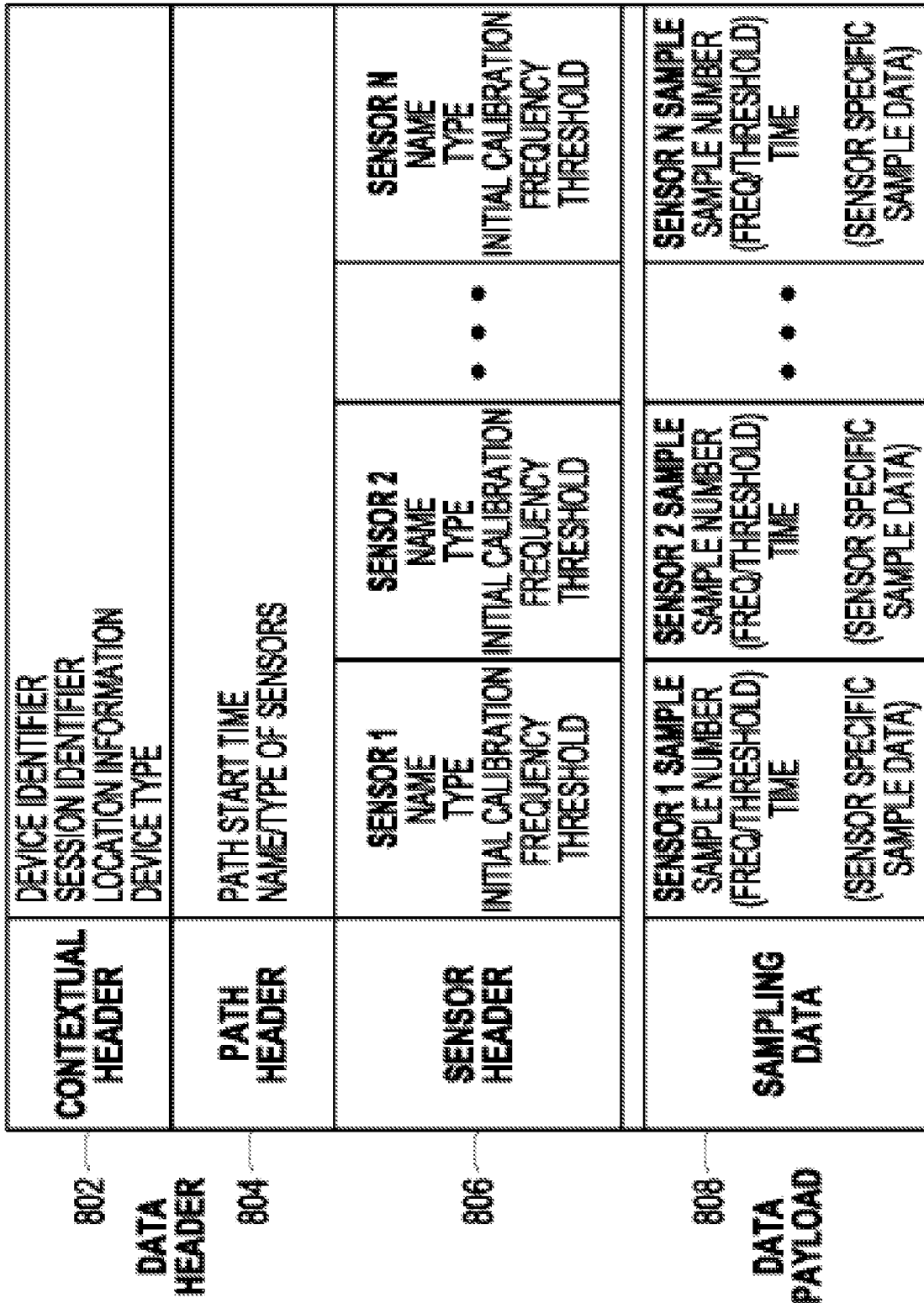

FIG. 8

9/21

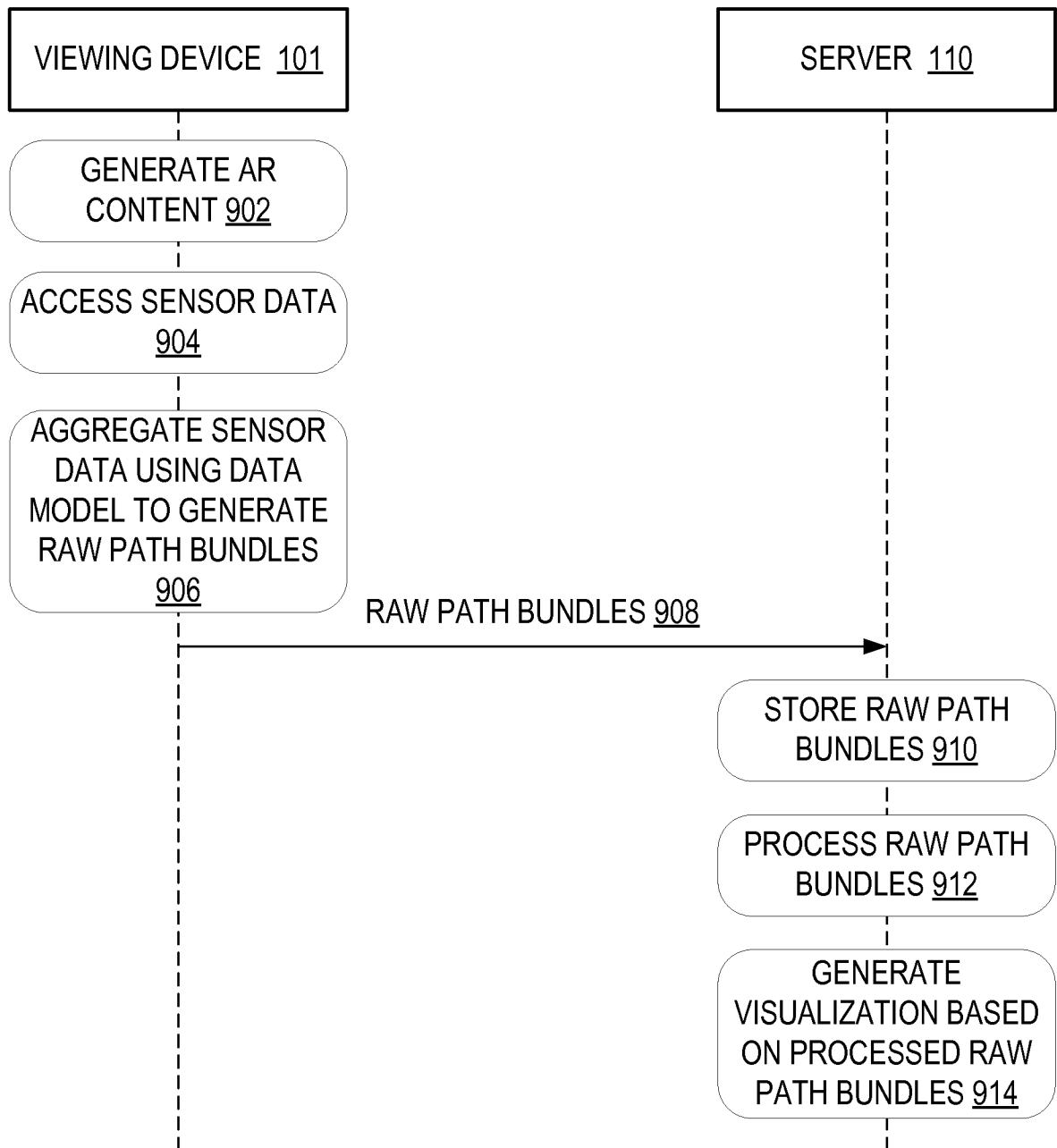

FIG. 9A

10/21

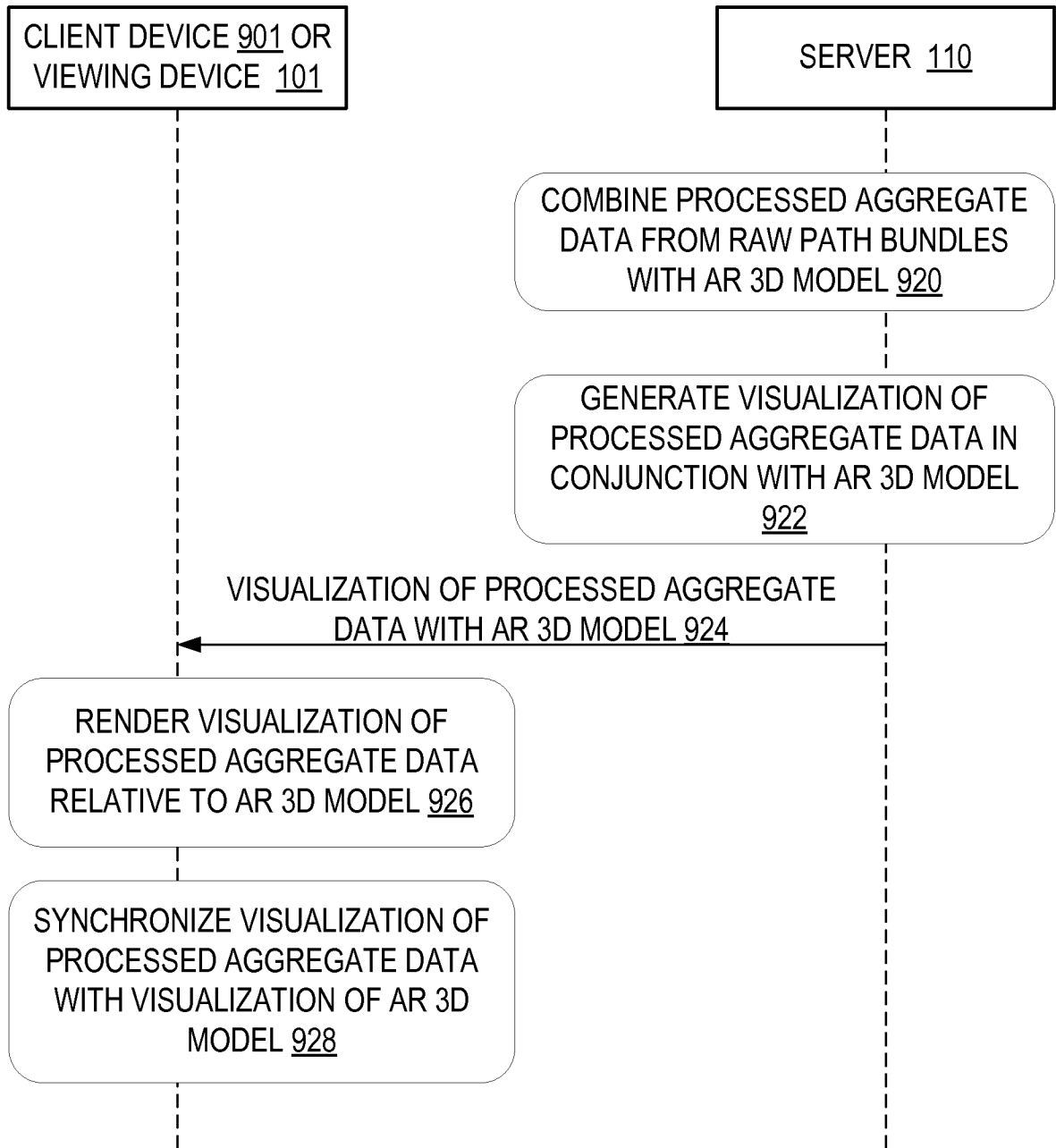

FIG. 9B

11/21

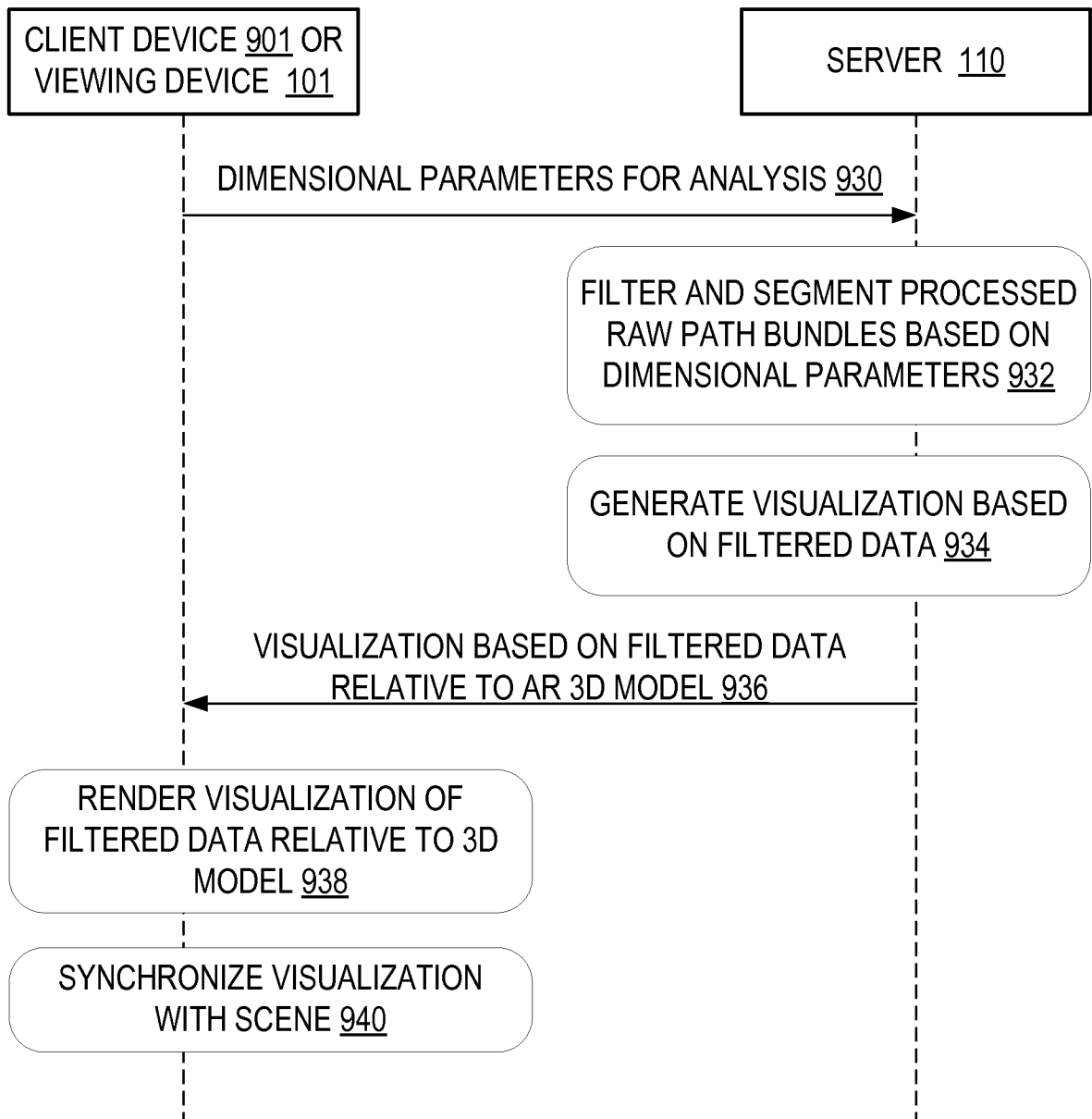

FIG. 9C

12/21

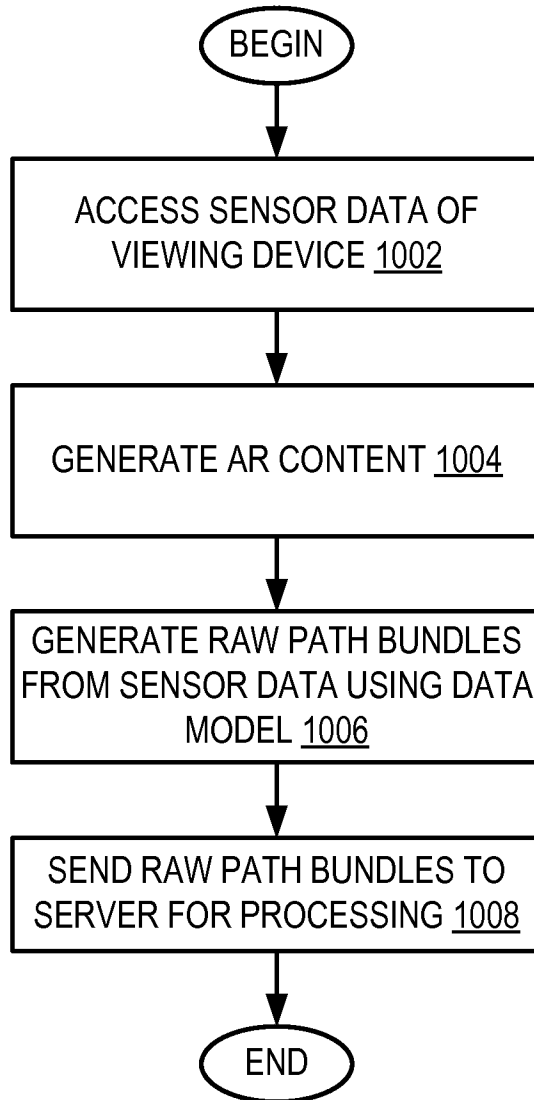

FIG. 10

13/21

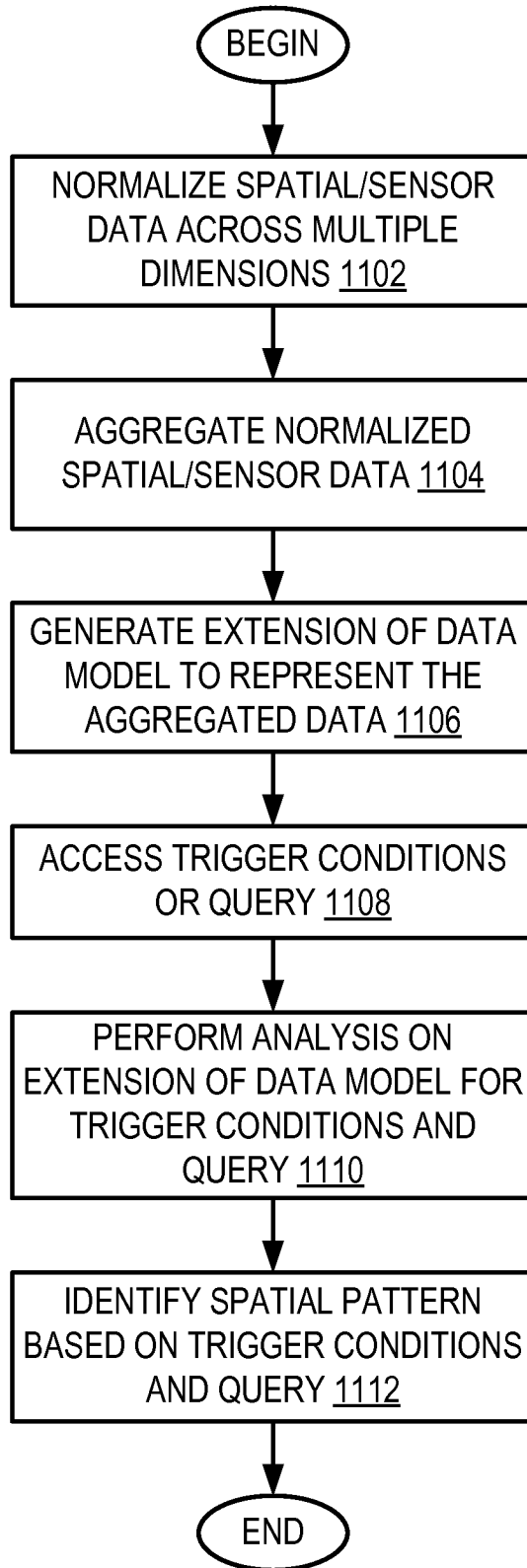

FIG. 11

14/21

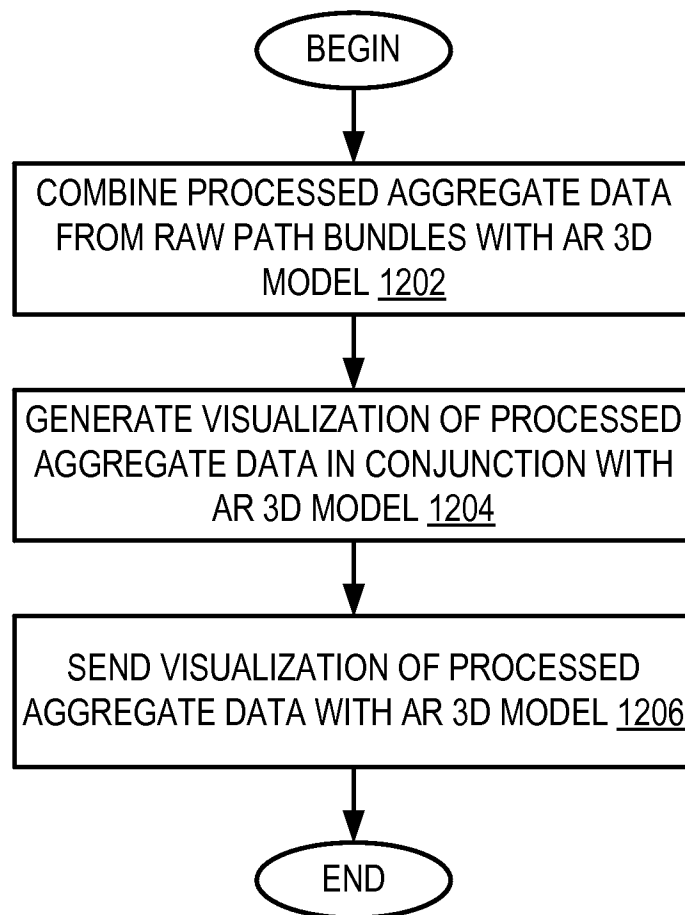

FIG. 12

15/21

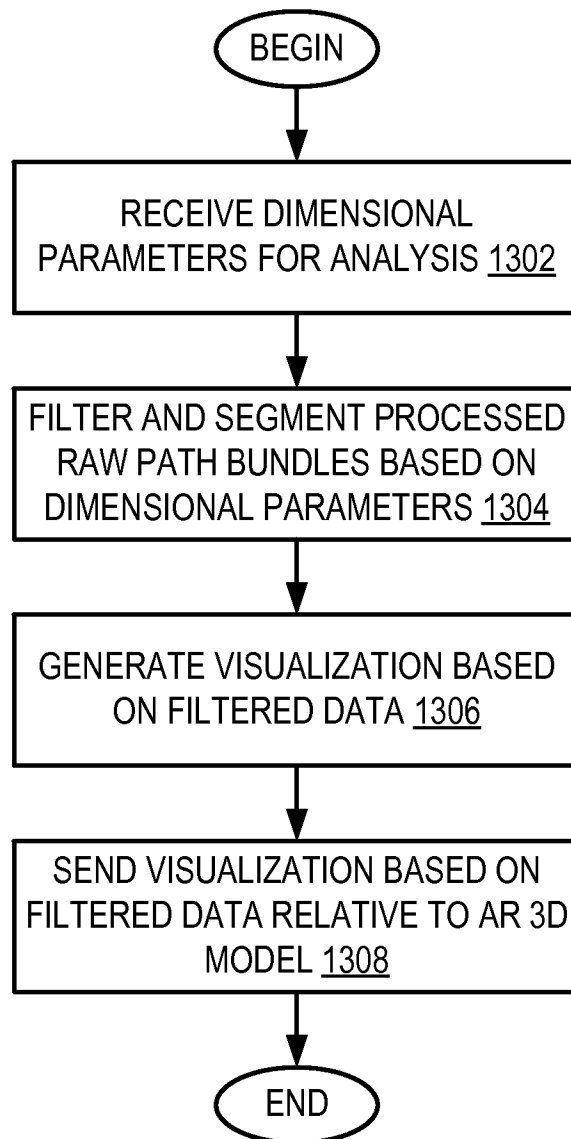

FIG. 13

16/21

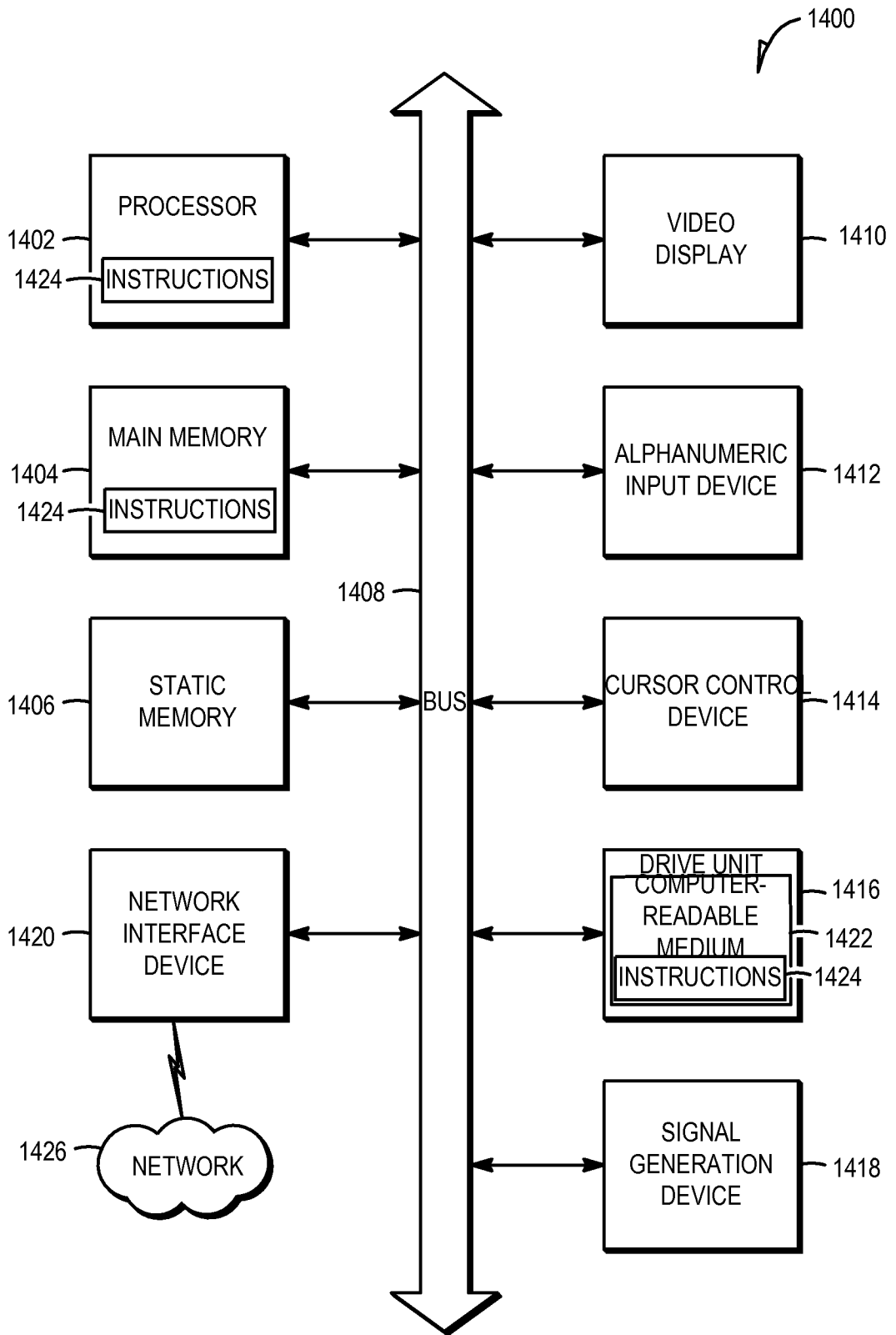

FIG. 14

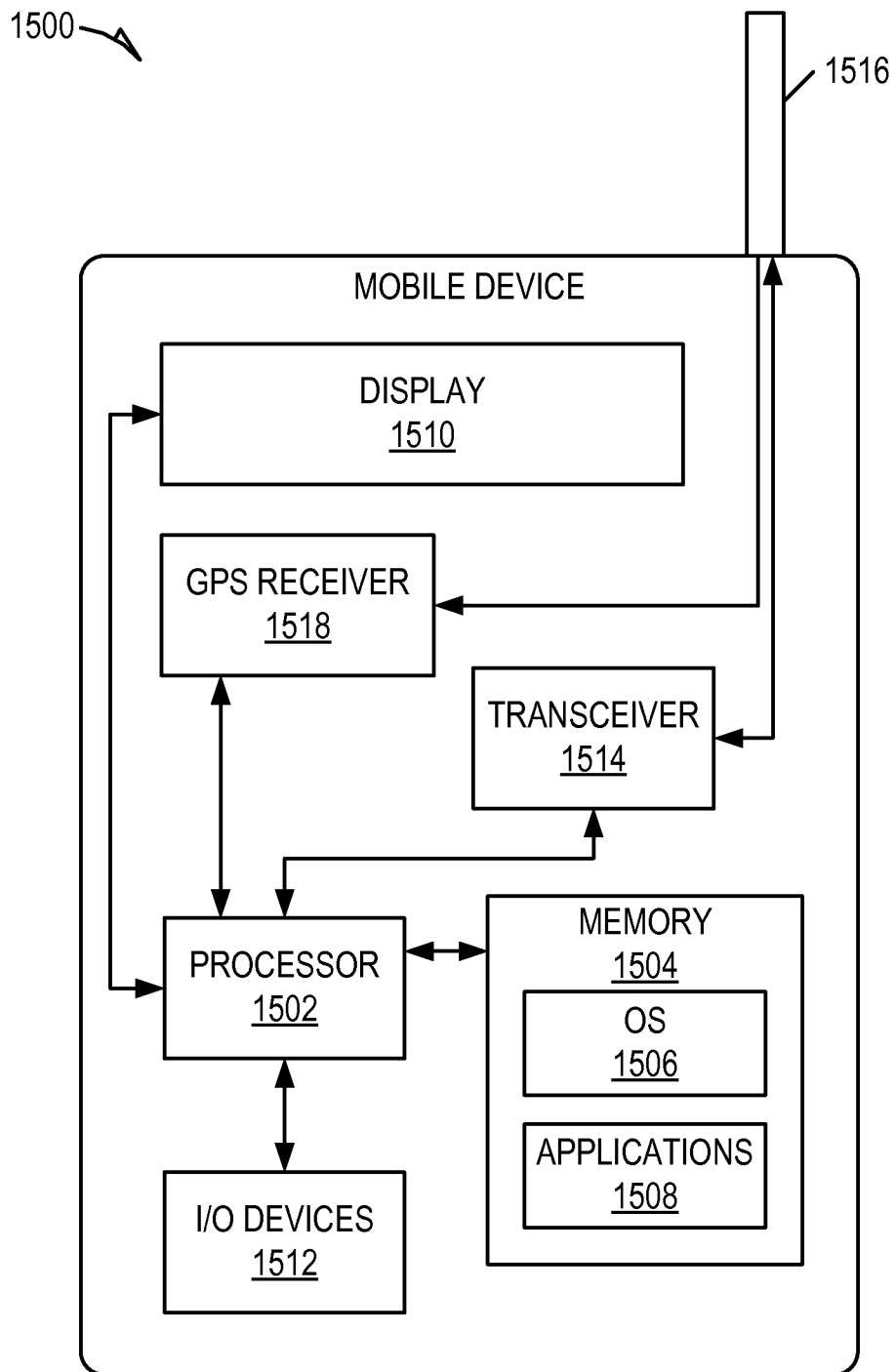

FIG. 15

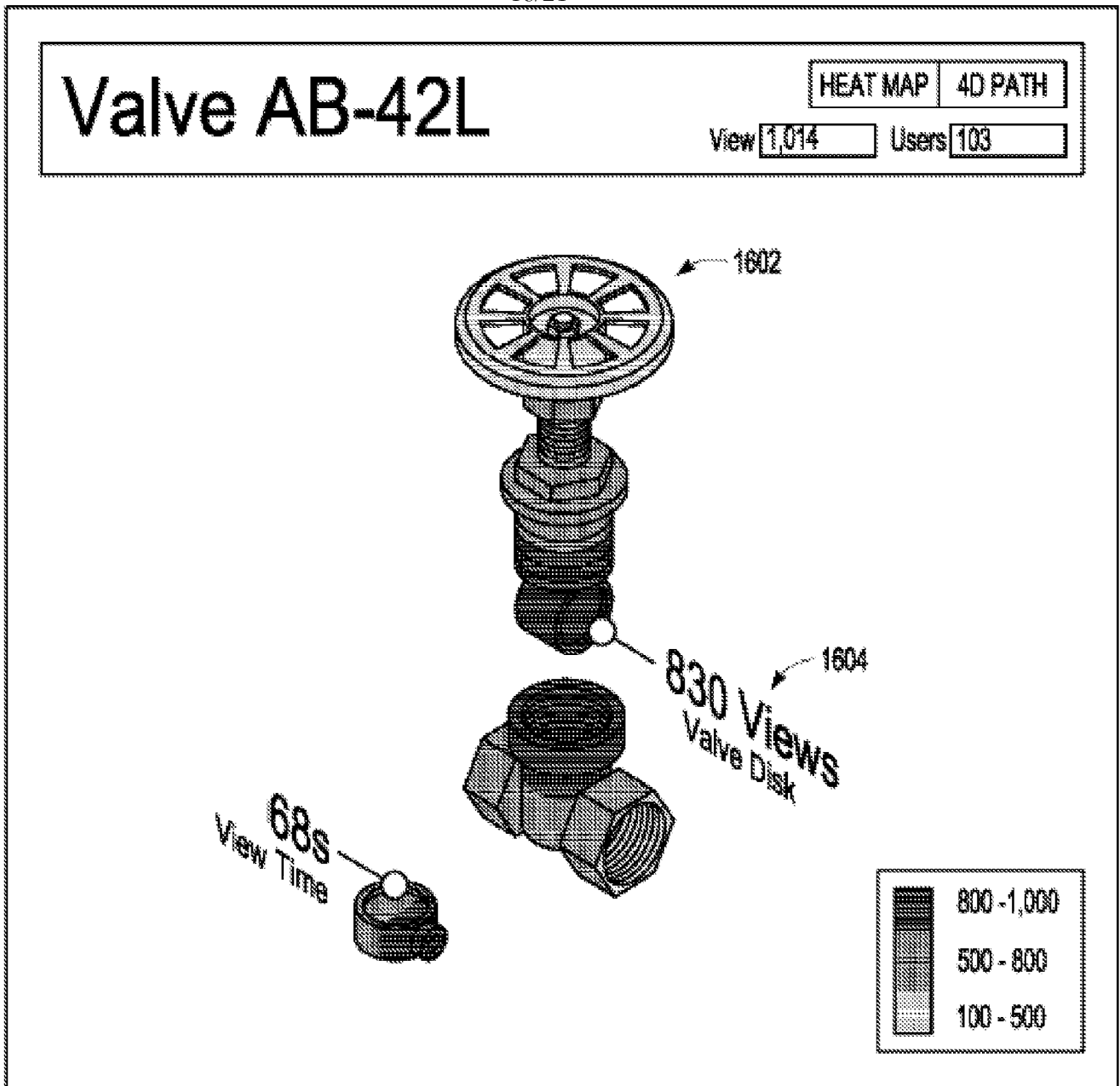

FIG. 16

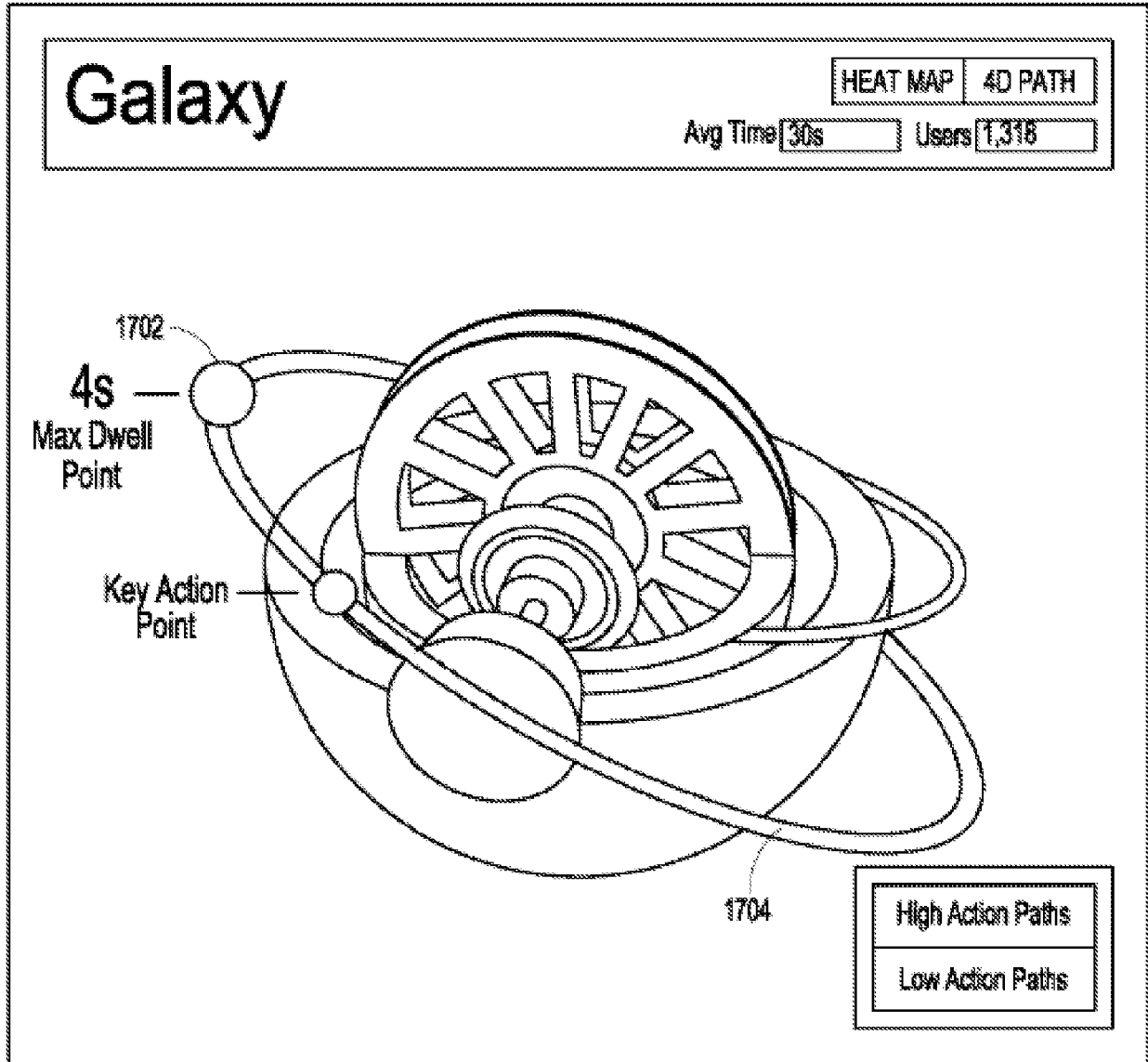

FIG. 17

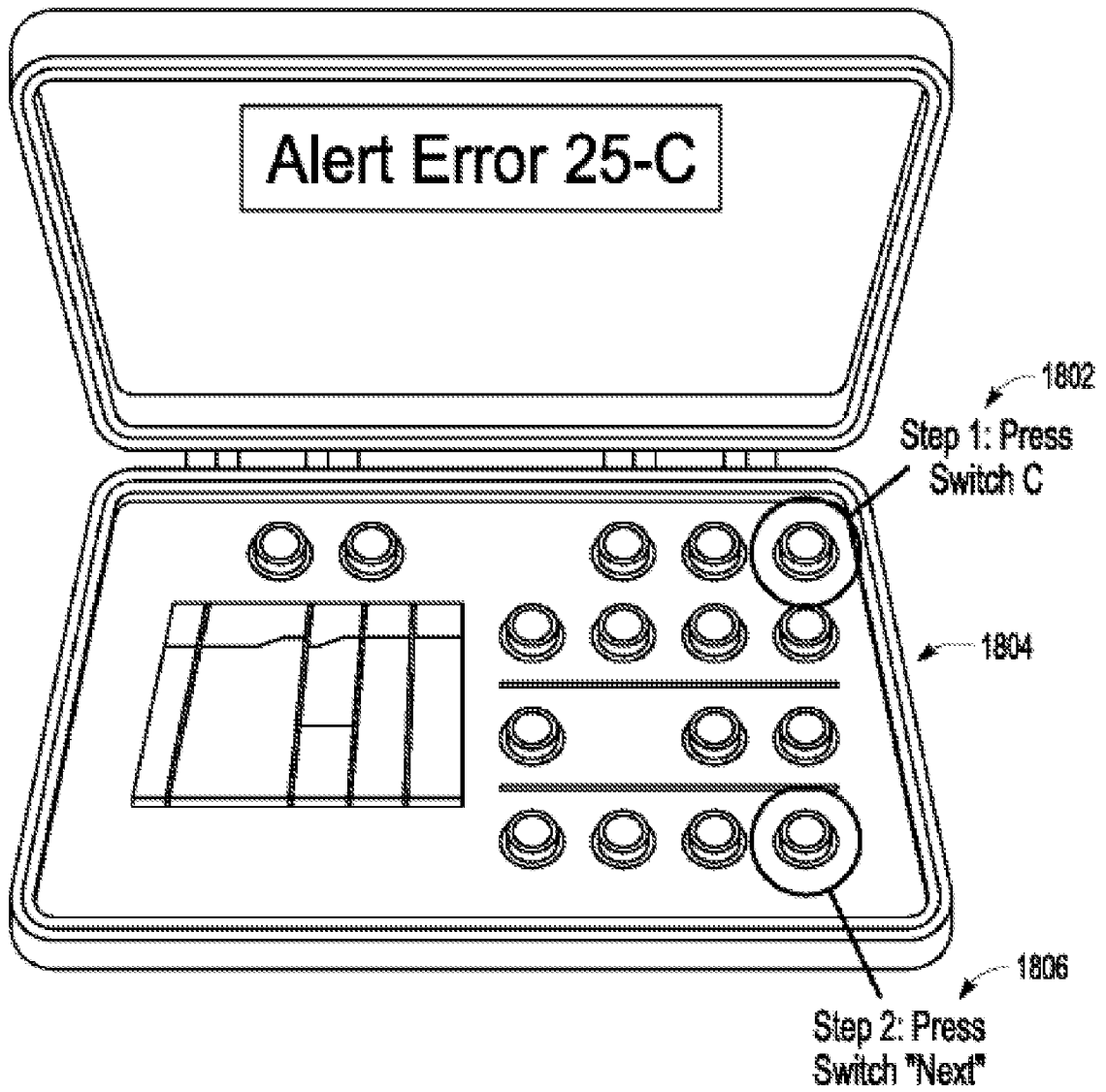

FIG. 18

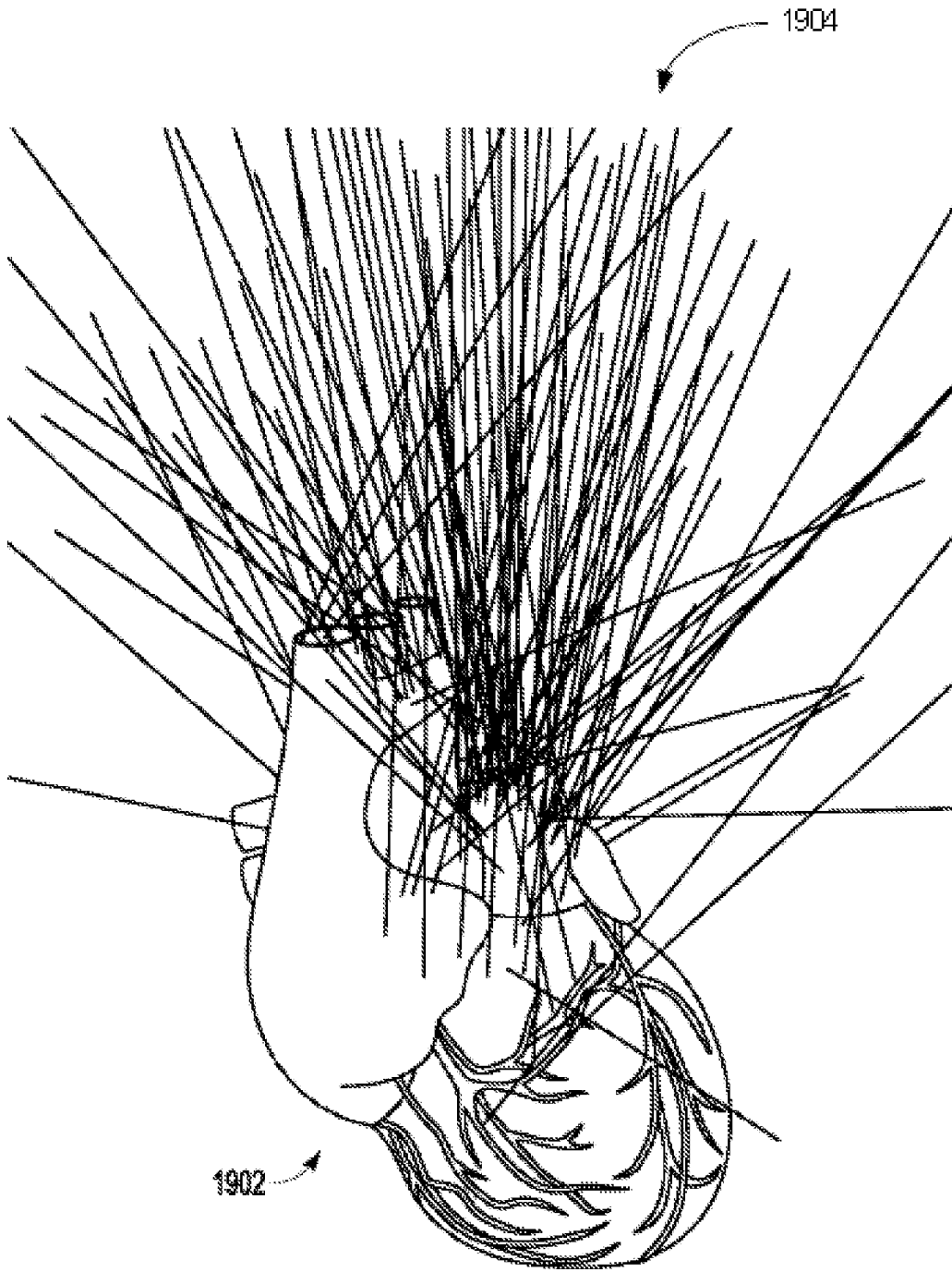

FIG. 19