



(51) International Patent Classification:

*F25B 9/02* (2006.01)      *F24F 12/00* (2006.01)  
*B01D 7/02* (2006.01)      *F28D 1/053* (2006.01)  
*B01D 49/00* (2006.01)      *F28F 1/00* (2006.01)  
*F24F 8/10* (2021.01)      *F28F 9/02* (2006.01)

(21) International Application Number:

PCT/SE2024/051035

(22) International Filing Date:

09 December 2024 (09.12.2024)

(25) Filing Language:

English

(26) Publication Language:

English

(30) Priority Data:

2351524-0      29 December 2023 (29.12.2023)      SE

(71) Applicant: **STOCKFORSA INVEST AB** [SE/SE]; Hel-  
lasvägen 4, MALMÖ 217 74 (SE).

(72) Inventor: **KARLSSON, Bengt-Göran**; Torsjö gård, Stora  
Torsjö 3196 A, 282 92 Västra Torup (SE).

(74) Agent: **AWA SWEDEN AB**; BOX 5117, 200 71 MALMÖ  
(SE).

(81) Designated States (*unless otherwise indicated, for every  
kind of national protection available*): AE, AG, AL, AM,  
AO, AT, AU, AZ, BA, BB, BG, BH, BN, BR, BW, BY, BZ,  
CA, CH, CL, CN, CO, CR, CU, CV, CZ, DE, DJ, DK, DM,  
DO, DZ, EC, EE, EG, ES, FI, GB, GD, GE, GH, GM, GT,  
HN, HR, HU, ID, IL, IN, IQ, IR, IS, IT, JM, JO, JP, KE, KG,  
KH, KN, KP, KR, KW, KZ, LA, LC, LK, LR, LS, LU, LY,  
MA, MD, MG, MK, MN, MU, MW, MX, MY, MZ, NA,  
NG, NI, NO, NZ, OM, PA, PE, PG, PH, PL, PT, QA, RO,  
RS, RU, RW, SA, SC, SD, SE, SG, SK, SL, ST, SV, SY, TH,

(54) Title: AN EVAPORATOR UNIT AND SYSTEM COMPRISING THE SAME, INTENDED FOR AIR VENTILATION SYSTEMS

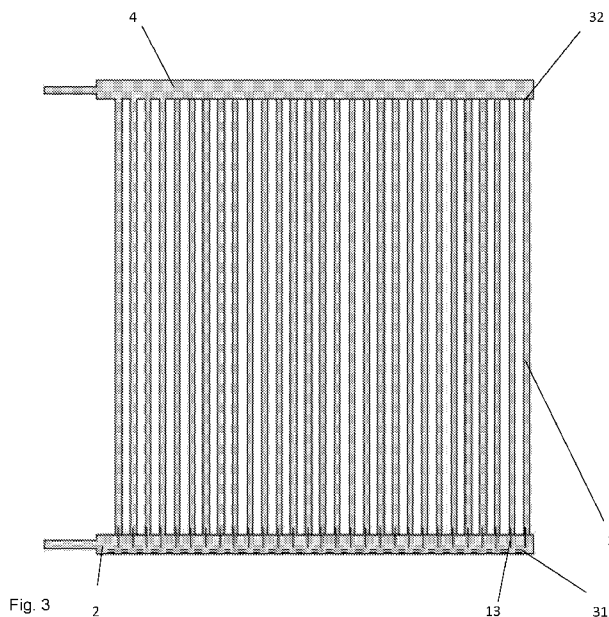

Fig. 3

(57) Abstract: The present invention describes an evaporator unit 1 intended for air ventilation systems, said evaporator unit 1 comprising - a sub-cooler chamber 15 arranged to hold cooling medium in liquid form; - a collection tube 2 arranged in connection to the sub-cooler chamber 15 and arranged for receiving cooling medium in a subcooled liquid form from the sub-cooler chamber 15, arranged to provide for a first sub-cooling in the evaporator unit 1; - multiple connection tubes 3 extending along an air cooling surface of the evaporator unit 1 and to their releasing ends 32, wherein the cooling medium transfers from a subcooled liquid phase to a gaseous phase along the multiple capillary tubes 3 via desublimation on an outside of the multiple connection tubes 3, arranged to provide for a second sub-cooling in the evaporator unit 1; - a releasing tube 4 connected to the releasing ends 32 of the multiple connection tubes 3, said releasing tube 4 arranged to flow the cooling medium in overheated gaseous phase to a compressor 60 of an energy recover system



WO 2025/144094 A1

TJ, TM, TN, TR, TT, TZ, UA, UG, US, UZ, VC, VN, WS,  
ZA, ZM, ZW.

**(84) Designated States** (*unless otherwise indicated, for every kind of regional protection available*): ARIPO (BW, CV, GH, GM, KE, LR, LS, MW, MZ, NA, RW, SC, SD, SL, ST, SZ, TZ, UG, ZM, ZW), Eurasian (AM, AZ, BY, KG, KZ, RU, TJ, TM), European (AL, AT, BE, BG, CH, CY, CZ, DE, DK, EE, ES, FI, FR, GB, GR, HR, HU, IE, IS, IT, LT, LU, LV, MC, ME, MK, MT, NL, NO, PL, PT, RO, RS, SE, SI, SK, SM, TR), OAPI (BF, BJ, CF, CG, CI, CM, GA, GN, GQ, GW, KM, ML, MR, NE, SN, TD, TG).

**Published:**

— *with international search report (Art. 21(3))*

---

100 of an air ventilation system; and - multiple capillary tubes 13 arranged with receiving ends 31 inside of the collection tube 2, said multiple capillary tubes 13 extending to or into a portion of the connection tubes 3.

AN EVAPORATOR UNIT AND SYSTEM COMPRISING THE SAME,  
INTENDED FOR AIR VENTILATION SYSTEMS

Field of the invention

The present invention relates to an evaporator unit and energy recovery system for air ventilation systems.

Technical Background

5 Industries have high demands on purifying the exhaust air from hazardous gases and materials containing in the air. It is also difficult to recover energy from the exhaust air in an industry or e.g. in a stable for birds, pigs, cows etc. The need for recover energy in the industry or stables etc. is great today. This is because the energy costs, e.g. for heating for the birds  
10 are very high. The ventilation in a stable is necessary so that the animals do not get hurt or die (common among birds). The same applies to industries. In industries there is a need to vent and draw out dangerous gases. Recovering energy from the exhaust air is not common as there are problems with aggressive gases, deposits on the materials and clogged heat exchangers.

15 Many stables and industries today have high energy costs and must find solutions to reduce these. The reason why exhaust air is not recycled in stables and industries today is the problems with deposits and harmful gases.

Moreover, different types of air ventilation systems exist on the market today. The present invention is directed to providing a new type of system  
20 which aims at both providing an improved air purification as well as an increased energy efficiency with respect to heat exchanging and thus energy needed for air ventilation systems.

Summary of the invention

The stated purpose above is achieved by an evaporator unit intended  
25 for air ventilation systems, said evaporator unit comprising

- a sub-cooler chamber arranged to hold cooling medium in liquid form;
- a collection tube arranged in connection to the sub-cooler chamber and arranged for receiving cooling medium in a subcooled liquid form from the sub-cooler chamber, arranged to provide for a first sub-cooling in the  
30 evaporator unit;

- multiple connection tubes extending along an air cooling surface of the evaporator unit and to their releasing ends, wherein the cooling medium transfers from a subcooled liquid phase to a gaseous phase along the multiple capillary tubes via desublimation on an outside of the multiple connection tubes, arranged to provide for a second sub-cooling in the evaporator unit;
- a releasing tube connected to the releasing ends of the multiple connection tubes, said releasing tube arranged to flow the cooling medium in overheated gaseous phase to a compressor of an energy recover system of an air ventilation system; and
- multiple capillary tubes arranged with receiving ends inside of the collection tube, said multiple capillary tubes extending to or into a portion of the connection tubes.

As said above, the evaporator unit according to the present invention provides an improved purification of the air as well as energy efficiency for a ventilation system. This is obtained by capturing particles, dirt and contaminants in the air. The concept of the present invention, and thus technical foundation for energy recovery is further explained below.

The concept of the present invention comprises three individual units working together. These are:

1. A wire heat exchanger unit, as part of the evaporator unit, with vertical tubes and direct expansion creating desublimation in the tubes/threads, which causes water in gaseous form to penetrate through any deposits and toward the pipe and turn into solid form. The water expands (about 9%) when it transitions to solid form/ice with a force of about 2000kg/cm<sup>2</sup>, and the expansion and force "blasts" away the layers stuck to the pipes.

2. A specially adapted capillary tube throttling with subcooling is connected to the chamber in the lower part of the evaporator unit. This is to create a subcooled liquid before it is led further into the pipes/threads. Supercooled liquid is needed to get a fast process and reaction when liquid goes through the second capillary tube into the exchanger. Here, a large cooling effect is needed inside the pipe to create desublimation in the wire

tubes of the evaporator unit. The wire tubes are in turn mounted in the exhaust air.

3. An energy recovery machine, where an adapted compressor, condenser and separator are equipped with a specially adapted electronic control. Here it may also be said that this control unit is suitable also  
5 controlling the defrosting operation mentioned below.

One function of the unit according to the present invention is releasing a large amount of energy in a short time, which creates a directed cooling effect towards the inside of the small wire tubes. Desublimation occurs, as  
10 mentioned above. As a high cooling effect is quickly transported through the material of the wire tubes, the conductivity is high, and this cooling effect is useful on the outside of the wire tubes. Here, the cooling effect will convert water in gaseous form to ice. If the high cooling effect is not achieved, water in gaseous form will first change to liquid and settle on the deposits stuck to  
15 the surface and then change to ice. For the purification to work, water in gaseous form must diffuse through the deposits and stick to the surface of the wire tubes in solid form. When this happens the water in gas form will change in volume. This occurs against the surface of the wire tubes, and this will blast away the deposits thereon as the water needs the place.

20 Each of the 3 units above are individually unique products for the market and together they have a completely unique function and solution for recycling and purifying exhaust air in industries, bathhouses, farms and stables, etc.

The evaporator unit and air ventilation system according to the present  
25 invention has a very high purification degree for air comprises particles. This type of air exists in most places today, both public and industrial. Moreover, it should be noted that ventilation systems used today is not adapted for purification of air with a high content of particles. The evaporator unit and air ventilation system are very suitable to handle such air types with a high  
30 degree of purification of and energy recover efficiency.

Another advantage of the evaporator unit according to the present invention is the fact that defrosting is simplified. Moreover, a defrosting procedure of the unit according to the present invention can be performed

when the evaporator unit is operating, and also in less than a couple of minutes.

As should be clear from above, also means for defrosting is a relevant part of a system according to the present invention.

#### 5 Brief description of the drawings

In fig. 1 there is shown one embodiment of an evaporator unit according to the present invention.

In fig. 2 there is shown another embodiment of an evaporator unit according to the present invention.

10 In fig. 3 there is shown one embodiment of an evaporator unit according to the present invention, seen in a cross sectional view.

In figs. 4a-4c there are shown different embodiments for capillary tubes arranged with receiving ends inside of the collection tube.

15 In fig. 4d there is shown one embodiment where the collection tube has a triangular shape in the bottom thereof.

In fig. 5 there is shown a system according to one embodiment of the present invention.

20 In figs. 6a and 6b there are shown the energy production (E+) / energy consumption (E-) vs time for a system according to one embodiment of the present invention and for a traditional system, respectively.

#### Specific embodiments of the invention

Below there is provided some specific embodiments of the present invention.

25 According to one embodiment of the present invention, the sub-cooler chamber is filled with the cooling medium in liquid form via a filling tube which is connected to a condenser unit of the energy recover system of the air ventilation system.

30 As mentioned above, the sub-cooler chamber in itself provides important functionality according to the present invention. Cooling medium from the condenser is hot and needs to be cooled down. To create a fast vaporization, the cooling medium is subcooled before direct expansion. By flowing in the liquid cooling medium in an inflow tube arranged also inside of the sub-cooler chamber this effect can be achieved. In the end of this inflow

tube part of the liquid cooling medium is evaporated, which also creates a cooling effect of the liquid cooling medium as such. Therefore, the liquid cooling medium becomes its own cooler, and no other extra heat exchanger is needed.

5           Based on the above, according to one embodiment of the present invention, the filling tube is a longitudinal tube ensuring that the cooling medium is provided and held in a sub-cooled liquid form in the sub-cooler chamber. The filling tube should be provided with a dimension small enough to ensure for the vaporization mentioned above.

10           According to yet another embodiment, the filling tube is provided along a substantial part of the inside of the sub-cooler chamber from one side to the other, preferably arranged to release the cooling medium in subcooled form in near proximity to one side of the sub-cooler chamber.

          As should be understood from above, the system according to the  
15           present invention provides throttling already at the inflow of liquid cooling medium, that is when flown from the condenser. This ensures that the sub-cooler chamber in fact contains a very cold liquid in the bottom of the sub-cooler chamber.

          Thereafter, a second throttling effect is obtained in the system from the  
20           collection tube an up into the multiple capillary tubes. As said, the evaporator unit according to the present invention comprises a collection tube arranged in connection to the sub-cooler chamber, and arranged for receiving cooling medium in a subcooled liquid form from the sub-cooler chamber. As may be noted from the below, the sub-cooler chamber may be one and the same unit  
25           as the collection tube, or one of them is a part of the other, or they may be two different units being connected to each other.

          Moreover, multiple capillary tubes are arranged with receiving ends  
          inside of the collection tube. According to one specific embodiment, the  
          multiple capillary tubes each provide a throttling in relation to the collection  
30           tube. This is preferred to ensure an efficient desublimation where the cooling medium transfers from a subcooled liquid phase to a gaseous phase along the multiple capillary tubes along the air cooling surface of the evaporator unit, to the releasing ends of the multiple capillary tubes.

As should be understood from above, two different types of throttling are obtained according to the present invention, and both provide important functionality.

According to one embodiment, the receiving ends are arranged as  
5 bents extending from the collection tube and into the connection tubes.  
According to another embodiment, the receiving ends are arranged as tube-in-tube arrangements from the collection tube and into the connection tubes.  
According to yet another embodiment, the receiving ends are arranged with less starting dimension when compared with the dimension of the connection  
10 tubes. Different alternatives are provided in fig. 4b and 4c, respectively.  
Others are of course possible according to the present invention.

As hinted above, according to one embodiment, the evaporator comprises a valve for defrosting connected to the collection tube.

Moreover, capillary tubes are an important aspect of the present  
15 invention. These are part of the evaporator unit according to the present invention. Fact is that there may also be a capillary tube provided in an earlier step. Therefore, according to one embodiment, the sub-cooler chamber comprises at least one capillary tube for increased effect in the first sub-cooling in the evaporator unit, preferably arranged in a recirculation loop also  
20 comprising a valve for defrosting connected to the sub-cooler chamber and thus collection tube.

Furthermore, the multiple capillary tubes ensure to capture sub-cooled liquid cooling medium from the collection tube. The multiple capillary tubes also ensure capturing of oil in the collection tube to avoid the formation of an  
25 oil trap. This also ensures to maintain efficiency of the system according to the present invention.

Moreover, the present invention also provides an energy recovery system intended for air ventilation systems, said system comprising an evaporator unit according to the present invention and an energy recovery  
30 unit comprising a condenser unit and a compressor. A suitable separator is also part of the energy recovery system.

According to yet a further embodiment, the present invention provides an air ventilation system comprising an energy recovery system according to above and an air inlet and an air outlet.

Furthermore, the present invention also provides an air ventilation  
5 system according to above, wherein the air ventilation system comprises a particle recover unit for collection of particles falling down from an outside of the connection tubes.

Moreover, the present invention is also directed to use of an air ventilation system according to the present invention, for purification of an air  
10 inlet flow so that particles and dirt in the inlet air flow is captured on the outside of the connection tubes, preferably collected in a particle recover unit after falling down from an outside of the connection tubes. In this regard it may be mentioned that the system according to the present invention may be used to purify ventilation air before this is blown off. Furthermore, the air inlet  
15 flow to the system according to the present invention exhaust air from a blowing fan.

#### Detailed description of the drawings

In fig. 1 there is shown one embodiment of an evaporator unit 1 according to the present invention. The evaporator unit 1 comprises a sub-cooler chamber 15 arranged to hold cooling medium in liquid form. The sub-cooler chamber 15 is in fluid connection to the collection tube 2. Moreover, in  
20 this case the collection tube 2 is in a rectangular shape. As should be note, also other shapes are possible, such also semicircular/circular and triangular, that latter being shown in fig. 4d. The - multiple capillary tubes 13 are arranged with receiving ends (31) inside of the collection tube (2) (see one  
25 example in fig. 3). The multiple connection tubes 3 extend along an air cooling surface of the evaporator unit 1 and to their releasing ends 32 (again, see fig. 3). In this case, the releasing tube 4 is in the same type of shape as the collection tube 2.

30 In fig. 2 there is shown another type of evaporator unit 1 according to the present invention. In this case the collection tubes 2 and the releasing tubes 4 are in circular shape.

In fig. 3 there is shown one embodiment of an evaporator unit 1 according to the present invention, seen in a cross sectional view. Here one type of multiple capillary tubes 13 are clearly shown, with receiving ends 31 inside of the collection tube 2. The connection tubes extend along an air cooling surface of the evaporator unit 1 and to releasing ends 32 ending into the releasing tube 4.

In figs. 4a-4c there are shown different embodiments for capillary tubes arranged with different types of receiving ends 31 inside of the collection tube.

Furthermore, in fig. 4d there is shown yet another embodiment according to the present invention (see also in fig. 5). In this case, the collection tube 2 has a triangular shape in the bottom thereof. The capillary tube 13 shown has a receiving end 31 in the bottom of the collection tube 2. Suitably, the receiving ends are more or less diagonally cut. Gas is collected in the upper part of the collection tube 2 and subcooled liquid is provided to the capillary tubes 31 in the V-shaped bottom of the collection tube 2. In line with the above, according to one embodiment, the collection tube has a V-shaped bottom and the receiving ends are arranged in close connection to the V-shaped bottom of the collection tube, preferably with diagonally cut receiving ends. As may be seen in fig. 4d, the capillary tubes 13 may extend as straight projections.

As mentioned, the evaporator unit 1 according to the present invention is intended for an energy recovery system intended for air ventilation systems. Such an energy recovery system also comprises a condenser unit where heat energy is obtained, and a compressor. Furthermore, the system also comprises a separator unit.

In fig. 5 there is shown a system according to one embodiment of the present invention, comprising an energy recovery system 100 according to one embodiment of the present invention. As can be seen, the evaporator unit 1 is connected to sub-cooler chamber 15. The sub-cooler chamber 15 is connected to the capillary tube 130. Furthermore, a throttling is provided from the filling tube 40, which is connected with a condenser 50, and into the capillary tube 130.

The energy recover system 100 comprises compressor 60 and a water loop (see also the pump 300) connected to the condenser 50, which suitably is a tube condenser.

Moreover, there is also provided a valve for defrosting 80, suitably a magnetic valve for defrosting, which is further discussed below.

In fig. 6a there is shown the energy production (E+) / energy consumption (E-) vs time for a system according to one embodiment of the present invention, and in fig. 6b there is shown the energy production (E+) / energy consumption (E-) vs time for a traditional system.

One important function of the system according to the present invention is the defrosting. As may be seen in fig. 5, a magnetic valve 80 is arranged in the system, and coupled over said at least one capillary tube 130 for increased effect in the first sub-cooling in the evaporator unit 1. To ensure that there is no expansion valve coupled to a receiver tank in the system is of importance. This to ensure that the compressor 60 is not damaged.

The system according to the present invention is based on use of capillary tubes and subcooling. This enables using a minimal amount of cooling medium. Moreover, the defrosting is possible by use of a 2-way magnetic valve.

When defrosting is performed, the circulation pump 300 over the condenser unit 50 is stopped during a short time until the condensation reaches 50°C. Thereafter, the 2-way magnetic valve 80 is opened and lets hot gas and warm liquid pass through. This passes as bypass over the first capillary tube 130 and then flows to the sub-cooler chamber 15 and is distributed over the connection tubes 3 in the evaporator unit 1 by means of the multiple capillary tubes 13. The temperature over the tubes in the evaporator unit 1 should not pass 4°C, to ensure that the tubes can take up energy and condensate from the ventilation air. The defrosting is performed during suitably 1 – 3 minutes, and when the system is started up again, then there is stored energy in the moisture on the connection tubes 3 and also from the material within the tubes.

The low overheating over the evaporator unit 1 of around 0.2 – 1 Kelvin (K) in the cooling medium cycle is important to obtain desublimation of water

vapor over the entire outer surfaces of the connection tubes 3. The multiple capillary tubes 13 provides for a “tube in tube” arrangement. This ensures an even distribution over the surfaces of the multiple capillary tubes 13. The multiple capillary tubes 13 also have the function to further sub-cool the liquid (cooling medium) before it enters the connection tubes 3. The capillary tubes 13 also ensures to bring oil from the bottom of collection tube 2. This further increases the efficiency of the system.

As may be seen in fig. 6a, the system never passes  $E = 0$  and delivers energy the entire way and retakes energy after the defrosting. This is a clear difference when comparing with a traditional system shown in fig. 6b where the energy passes  $E = 0$  to the negative side, meaning that energy is consumed from the heating system.

The entire system may be arranged in one single unit, such as in a box unit, which is possible to install as one single unit. The system needs a waste fluid for separation, electricity for controlling functions etc. and two heating pipes, one for delivery and one return pipe.

Sizes and shapes of different units mentioned above may vary depending on the intended effect, usage and place of use. Also the number of multiple capillary tubes may vary depending on the intended effect and usage. Several tube rows may also be arranged according to the present invention.

Material of different components may be adapted based on the type of air been purified, such as based on the aggressiveness of the content of the air.

The cooling medium used may be such used standardized today, and suitably adapted for gases and particles intended to be collected from the air, e.g. ethanol, cooling oils etc. Moreover, on the heating side, water is suitably used.

## Claims

1. An evaporator unit (1) intended for air ventilation systems, said evaporator  
5 unit (1) comprising
- a sub-cooler chamber (15) arranged to hold cooling medium in liquid form;
  - a collection tube (2) arranged in connection to the sub-cooler chamber (15)  
and arranged for receiving cooling medium in a subcooled liquid form from  
the sub-cooler chamber (15), arranged to provide for a first sub-cooling in the  
10 evaporator unit (1);
  - multiple connection tubes (3) extending along an air cooling surface of the  
evaporator unit (1) and to their releasing ends (32), wherein the cooling  
medium transfers from a subcooled liquid phase to a gaseous phase along  
the multiple capillary tubes (3) via desublimation on an outside of the multiple  
15 connection tubes (3), arranged to provide for a second sub-cooling in the  
evaporator unit (1);
  - a releasing tube (4) connected to the releasing ends (32) of the multiple  
connection tubes (3), said releasing tube (4) arranged to flow the cooling  
medium in overheated gaseous phase to a compressor (60) of an energy  
20 recover system (100) of an air ventilation system; and
  - multiple capillary tubes (13) arranged with receiving ends (31) inside of the  
collection tube (2), said multiple capillary tubes (13) extending to or into a  
portion of the connection tubes (3).
- 25 2. The evaporator unit (1) according to claim 1, wherein the sub-cooler  
chamber (15) is filled with the cooling medium in liquid form via a filling tube  
(40) which is connected to a condenser unit (50) of the energy recover  
system (100) of the air ventilation system.
- 30 3. The evaporator unit (1) according to claim 2, wherein the filling tube (40) is  
a longitudinal tube ensuring that the cooling medium is provided and held in a  
sub-cooled liquid form in the sub-cooler chamber (15).

4. The evaporator unit (1) according to claim 2 or 3, wherein the filling tube (40) is provided along a substantial part of the inside of the sub-cooler chamber (15) from one side to the other, preferably arranged to release the cooling medium in subcooled form in near proximity to one side of the sub-cooler chamber (15).
5. The evaporator unit (1) according to any of claims 1-4, wherein the multiple capillary tubes (13) each provide a throttling in relation to the collection tube (2).
6. The evaporator unit (1) according to any of claims 1-5, wherein the receiving ends (31) are arranged as bents extending from the collection tube (2) and into the connection tubes (3).
7. The evaporator unit (1) according to any of claims 1-6, wherein the receiving ends (31) are arranged as tube-in-tube arrangements from the collection tube (2) and into the connection tubes (3).
8. The evaporator unit (1) according to any of claims 1-7, wherein the receiving ends (31) are arranged with less starting dimension when compared with the dimension of the connection tubes (3).
9. The evaporator unit (1) according to any of claims 1-8, wherein the collection tube (2) has a V-shaped bottom and wherein the receiving ends (31) are arranged in close connection to the V-shaped bottom of the collection tube, preferably with diagonally cut receiving ends (31).
10. The evaporator unit (1) according to any of claims 1-9, wherein the evaporator (1) comprises a valve (80) for defrosting connected to the collection tube (2).
11. The evaporator unit (1) according to any of claims 1-10, wherein the sub-cooler chamber (15) comprises at least one capillary tube (130) for increased

effect in the first sub-cooling in the evaporator unit (1), preferably arranged in a recirculation loop also comprising a valve (80) for defrosting connected to the sub-cooler chamber (15) and thus the collection tube (2).

- 5 12. An energy recovery system (100) intended for air ventilation systems, said system comprising an evaporator unit (1) according to any of claims 1-11 and an energy recovery unit comprising a condenser unit (50) and a compressor (60).
- 10 13. An air ventilation system comprising an energy recovery system (100) according to claim 11 and an air inlet and an air outlet.
14. The air ventilation system according to claim 13, wherein the air ventilation system comprises a particle recover unit for collection of particles  
15 falling down from an outside of the multiple connection tubes (3).
15. Use of an air ventilation system according to claim 13 or 14, for purification of an air inlet flow so that particles and dirt in the inlet air flow is captured on the outside of the connection tubes (3), preferably collected in a  
20 particle recover unit after falling down from an outside of the multiple connection tubes (3).

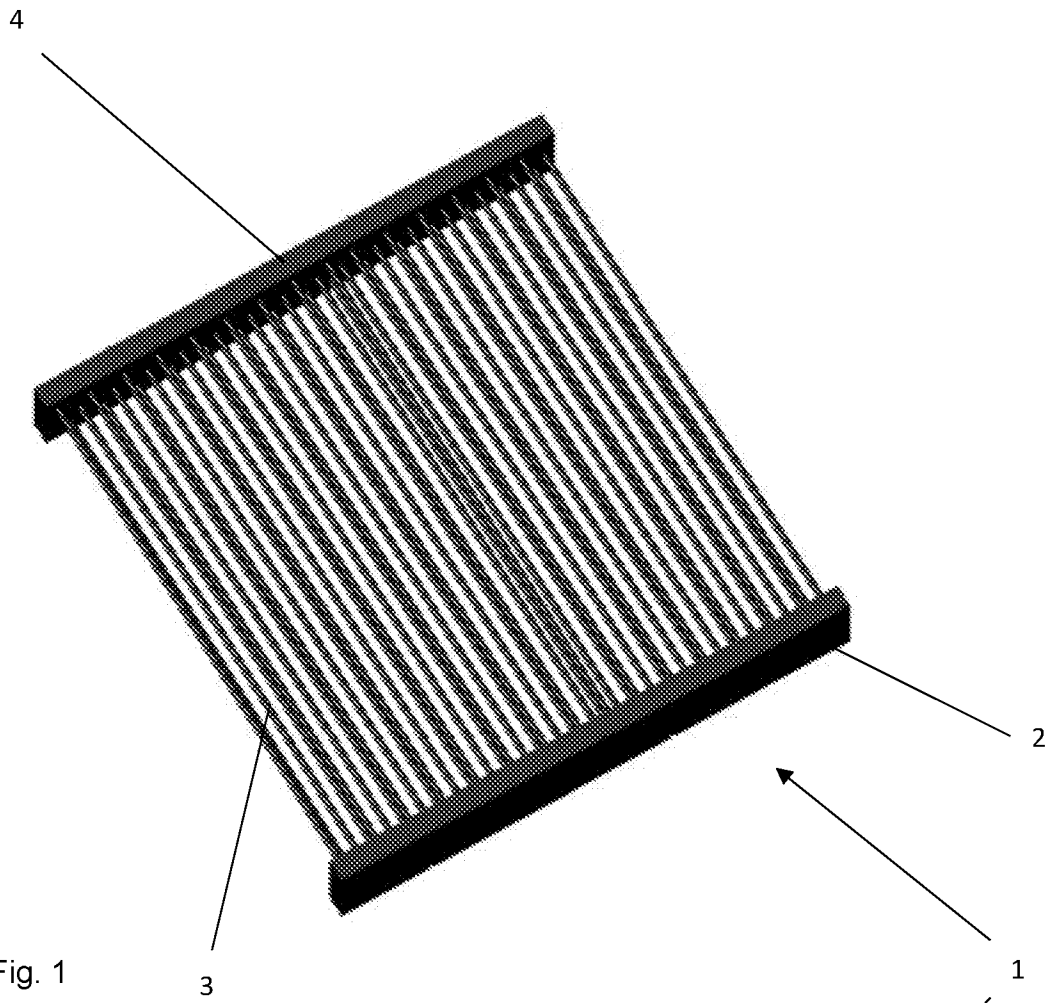

Fig. 1

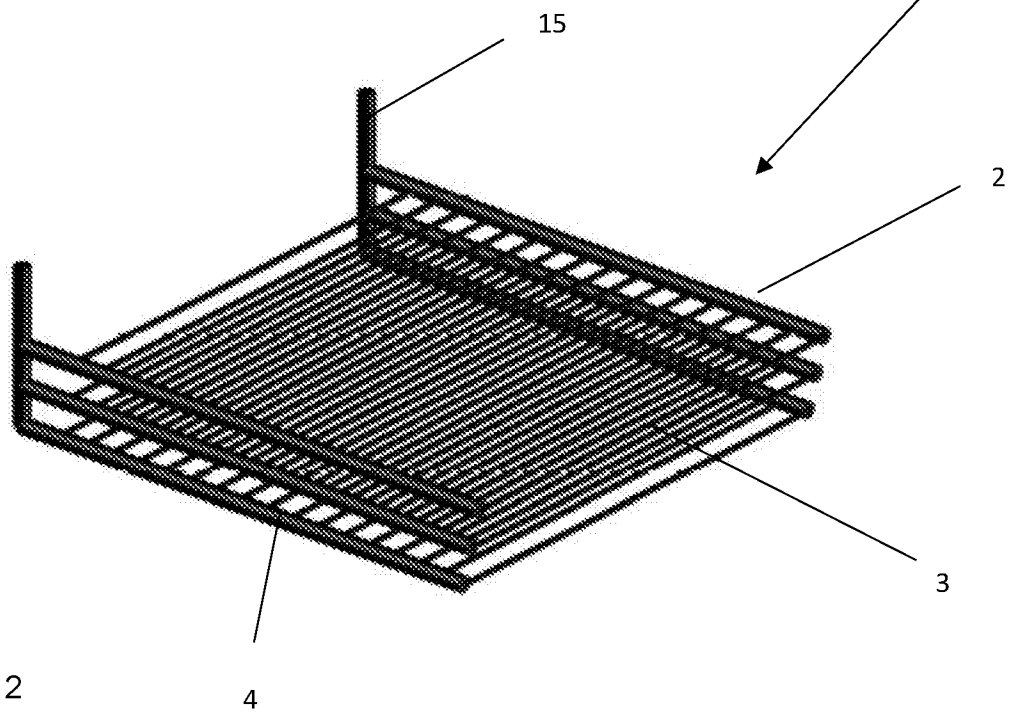

Fig. 2

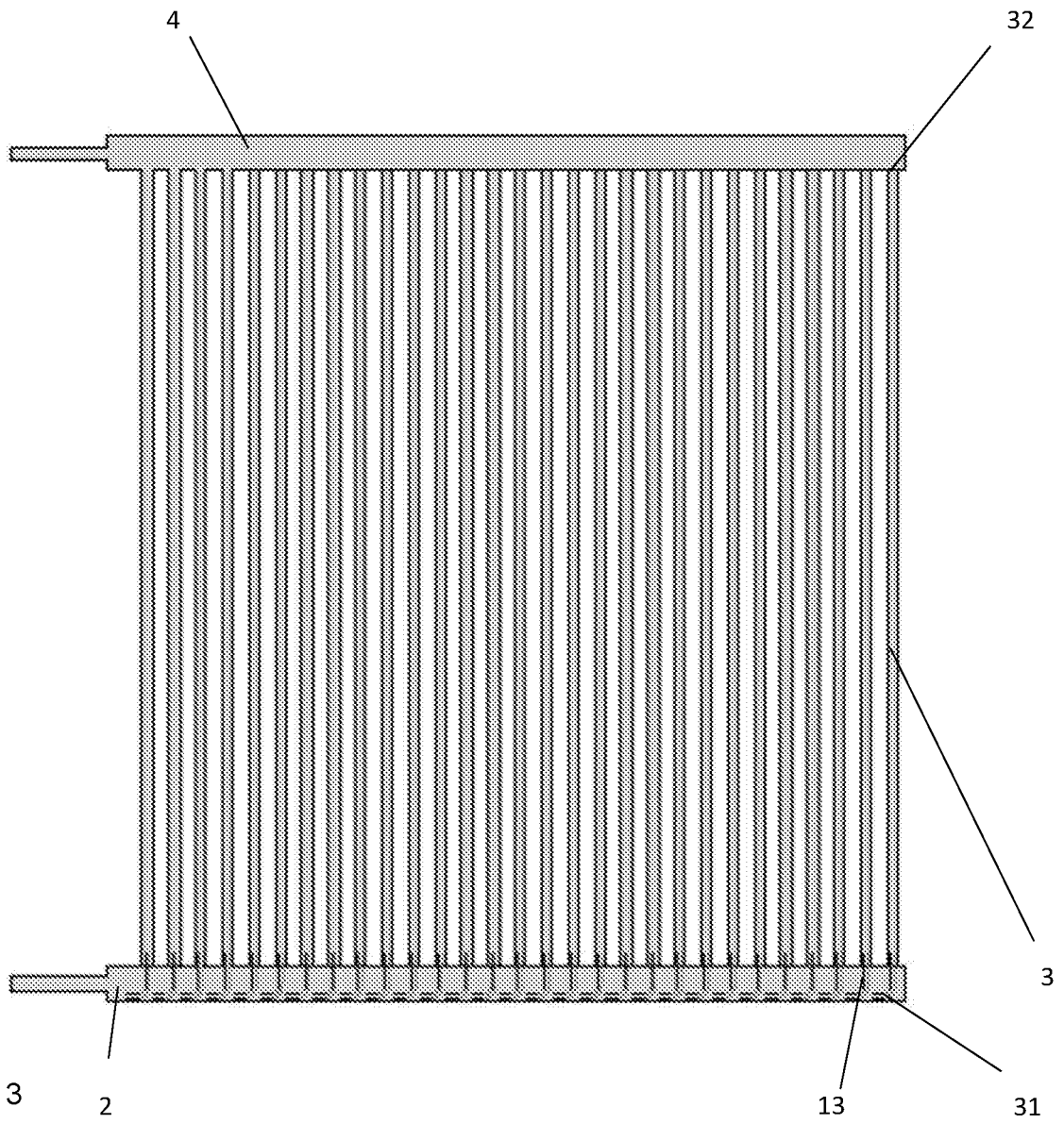

Fig. 3

2

13

31

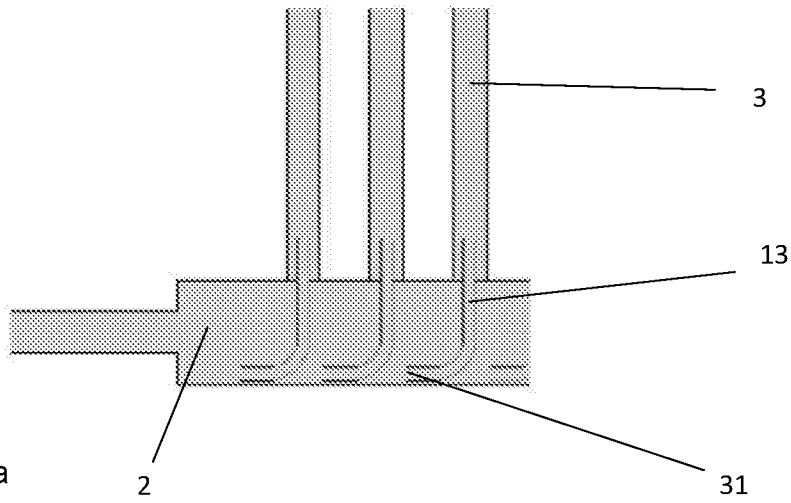

Fig. 4a

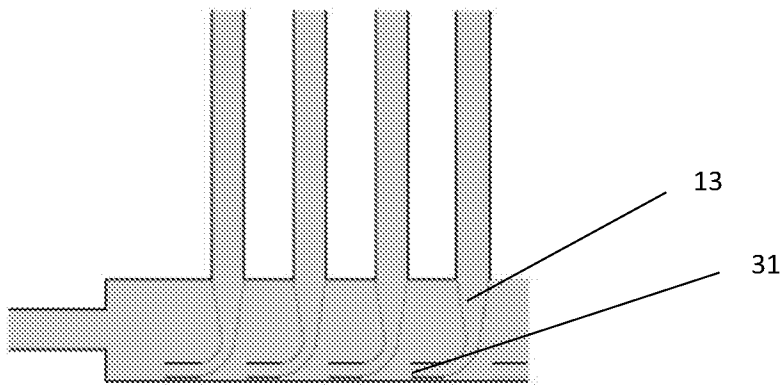

Fig. 4b

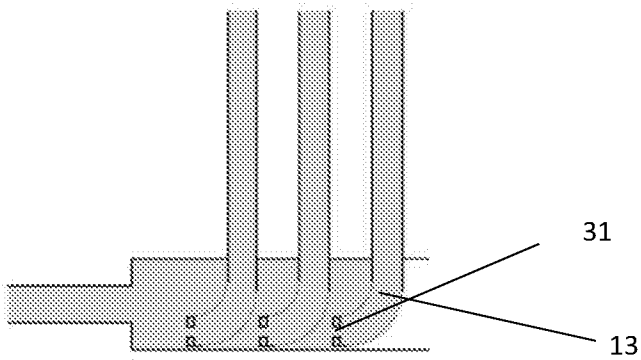

Fig. 4c

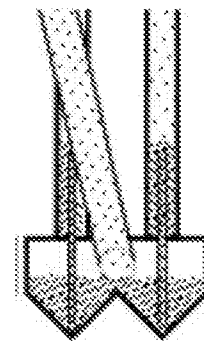
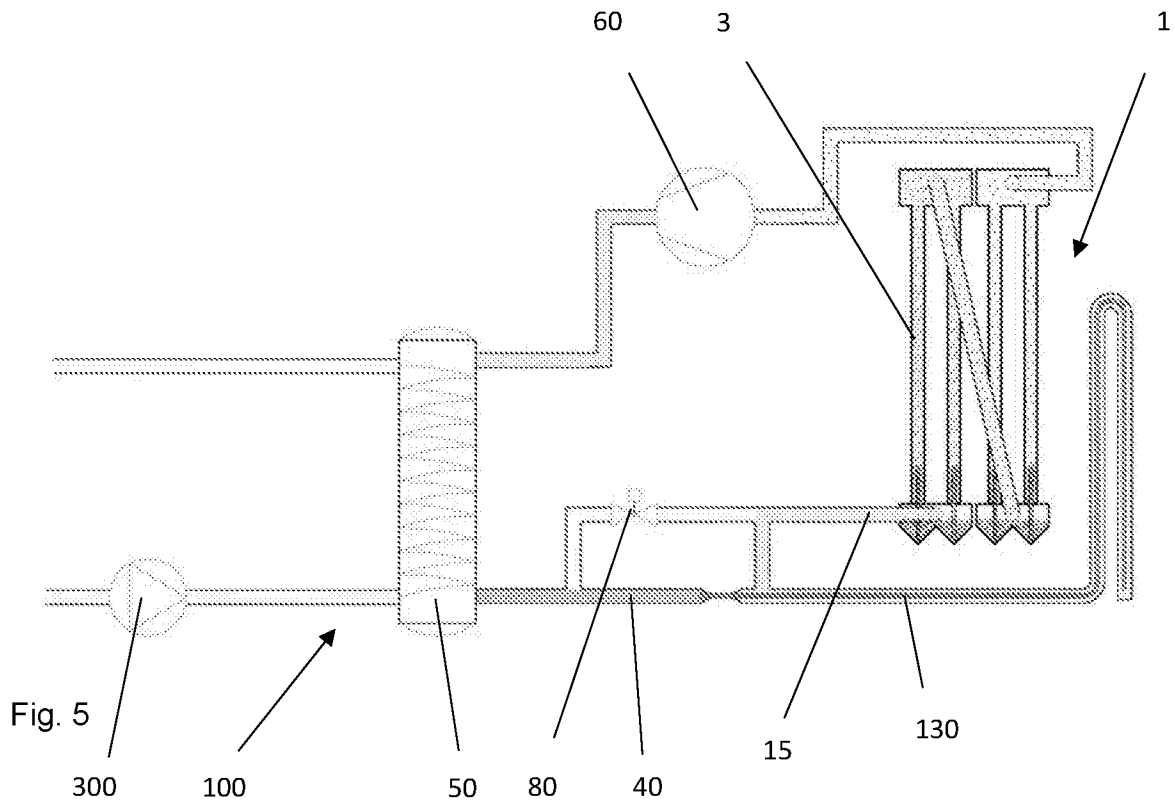

Fig. 4d



SYSTEM ACCORDING TO THE PRESENT INVENTION

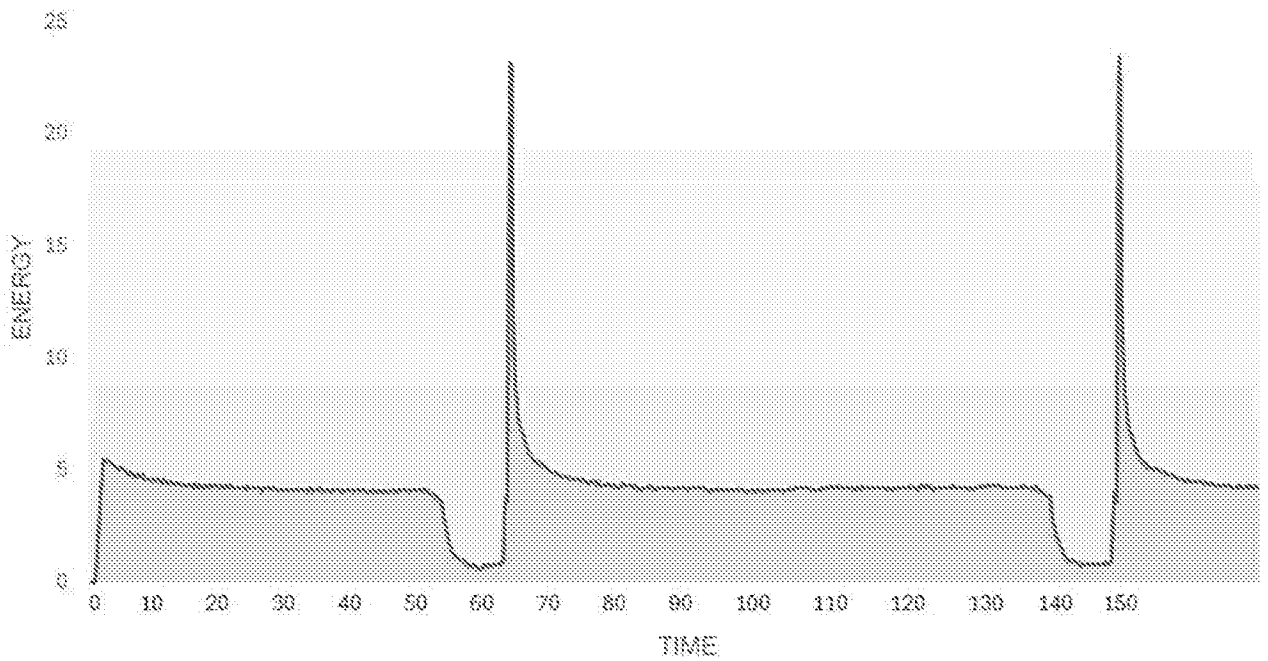

Fig. 6A

A TRADITIONAL SYSTEM

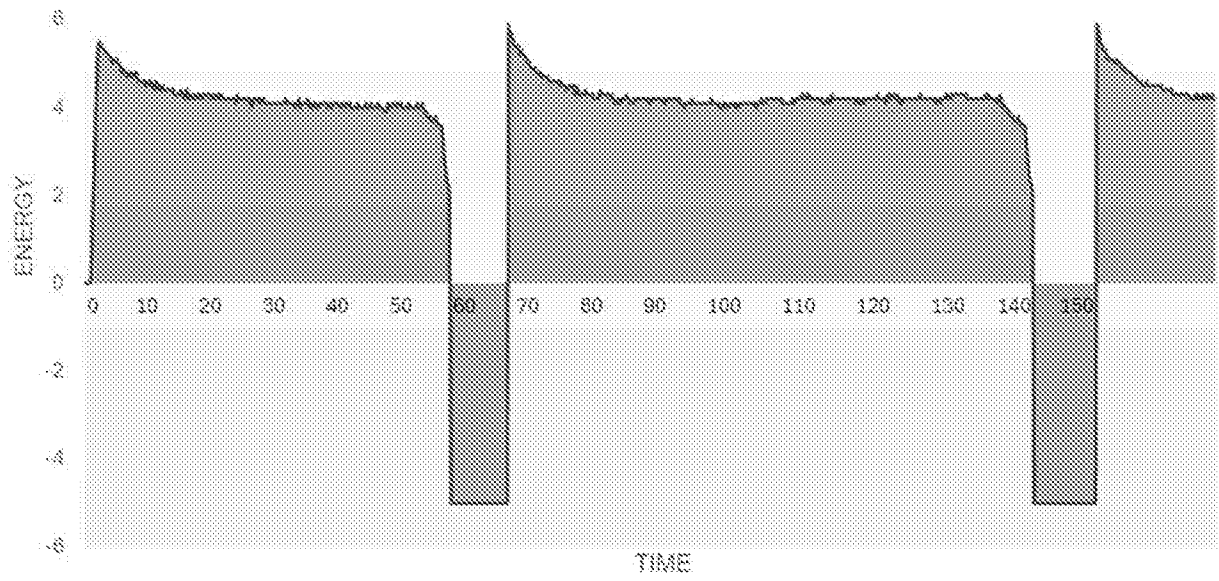

Fig. 6B

## INTERNATIONAL SEARCH REPORT

International application No.  
PCT/SE2024/051035

A. CLASSIFICATION OF SUBJECT MATTER		
IPC: see extra sheet		
According to International Patent Classification (IPC) or to both national classification and IPC		
B. FIELDS SEARCHED		
Minimum documentation searched (classification system followed by classification symbols)		
IPC: B01D, F24F, F25B, F28D, F28F		
Documentation searched other than minimum documentation to the extent that such documents are included in the fields searched		
SE, DK, FI, NO classes as above		
Electronic data base consulted during the international search (name of data base and, where practicable, search terms used)		
KIME		
C. DOCUMENTS CONSIDERED TO BE RELEVANT		
Category*	Citation of document, with indication, where appropriate, of the relevant passages	Relevant to claim No.
X	US 20220221227 A1 (WAGNER ANDREAS ET AL), 14 July 2022 (2022-07-14); abstract; paragraphs [0037], [0051]-[0052], [0058], [0070]-[0073], [0079], [0081], [0153]; figures 1, 2a-2b, 2c-2d, 2g, 3, 6	1-11
Y	--	12-15
Y	WO 2019048542 A1 (ENJAY AB), 14 March 2019 (2019-03-14); abstract; page 6, line 1 - line 23; page 8, line 14 - line 25; page 9, line 10 - line 14; page 9, line 29 - page 10, line 4; page 11, line 21 - page 12, line 12; figures 1, 4; claims 1-3	12-15
	--	
<input checked="" type="checkbox"/>	Further documents are listed in the continuation of Box C.	<input checked="" type="checkbox"/> See patent family annex.
* Special categories of cited documents:		
"A" document defining the general state of the art which is not considered to be of particular relevance		"T" later document published after the international filing date or priority date and not in conflict with the application but cited to understand the principle or theory underlying the invention
"D" document cited by the applicant in the international application		"X" document of particular relevance; the claimed invention cannot be considered novel or cannot be considered to involve an inventive step when the document is taken alone
"E" earlier application or patent but published on or after the international filing date		
"L" document which may throw doubts on priority claim(s) or which is cited to establish the publication date of another citation or other special reason (as specified)		"Y" document of particular relevance; the claimed invention cannot be considered to involve an inventive step when the document is combined with one or more other such documents, such combination being obvious to a person skilled in the art
"O" document referring to an oral disclosure, use, exhibition or other means		
"P" document published prior to the international filing date but later than the priority date claimed		"&" document member of the same patent family
Date of the actual completion of the international search	Date of mailing of the international search report	
18-02-2025	19-02-2025	
Name and mailing address of the ISA/SE Patent- och registreringsverket Box 5055 S-102 42 STOCKHOLM Facsimile No. + 46 8 666 02 86	Authorized officer Fabiola Baina Telephone No. + 46 8 782 28 00	

## INTERNATIONAL SEARCH REPORT

International application No.  
PCT/SE2024/051035

C (Continuation). DOCUMENTS CONSIDERED TO BE RELEVANT		
Category*	Citation of document, with indication, where appropriate, of the relevant passages	Relevant to claim No.
X	US 20080105420 A1 (TARAS MICHAEL F ET AL), 8 May 2008 (2008-05-08); abstract; paragraphs [0027]-[0029]; figure 2; claim 1 --	1-11
X	WO 2011003416 A2 (DANFOSS AS ET AL), 13 January 2011 (2011-01-13); page 10, line 9 - page 11, line 2; figure 3 --	1-11
A	JP 3158722 B2 (DAIKIN IND LTD), 23 April 2001 (2001-04-23); all figures; see machine translation abstract. --	1-15
A	JP 3122578 B2 (SHARP KK), 9 January 2001 (2001-01-09); all figures; see machine translation abstract. --	1-15
A	CN 206959099 U (NINGBO FOTILE KITCHEN WARE CO), 2 February 2018 (2018-02-02); all figures; see machine translation abstract. --	1-15
A	CN 107543336 A (HANGZHOU SANHUA HOME APPLIANCE THERMAL MAN SYSTEM CO LTD), 5 January 2018 (2018-01-05); figure 3; see machine translation abstract. -- -----	1-15

**Continuation of:** second sheet

**International Patent Classification (IPC)**

**F25B 9/02** (2006.01)

**B01D 7/02** (2006.01)

**B01D 49/00** (2006.01)

**F24F 8/10** (2021.01)

**F24F 12/00** (2006.01)

**F28D 1/053** (2006.01)

**F28F 1/00** (2006.01)

**F28F 9/02** (2006.01)

## INTERNATIONAL SEARCH REPORT

Information on patent family members

International application No.

PCT/SE2024/051035

US	20220221227	A1	14/07/2022	CN	114144628	A	04/03/2022
				DE	102019113327	A1	26/11/2020
				EP	3973242	A1	30/03/2022
				JP	2022533701	A	25/07/2022
				US	11994346	B2	28/05/2024
				WO	2020234358	A1	26/11/2020
WO	2019048542	A1	14/03/2019	SE	542699	C2	30/06/2020
				SE	1751074	A1	07/03/2019
US	20080105420	A1	08/05/2008	AU	2005326710	A1	10/08/2006
				BR	PI0519905	A2	08/09/2009
				CA	2596364	A1	10/08/2006
				CN	101443621	A	27/05/2009
				EP	1859220	A2	28/11/2007
				JP	2008533415	A	21/08/2008
				KR	20070091216	A	07/09/2007
				MX	2007009248	A	04/09/2007
				WO	2006083442	A2	10/08/2006
WO	2011003416	A2	13/01/2011	NONE			
JP	3158722	B2	23/04/2001	NONE			
JP	3122578	B2	09/01/2001	NONE			
CN	206959099	U	02/02/2018	NONE			
CN	107543336	A	05/01/2018	NONE			