

Frey, Allen & Smith,

Metal Barrel.

N^o 53,970.

Patented Apr. 17, 1866.

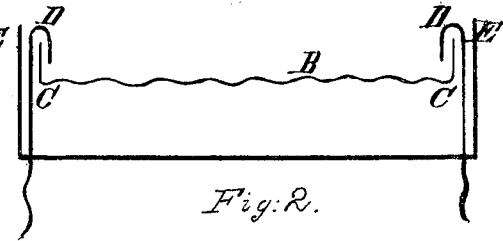
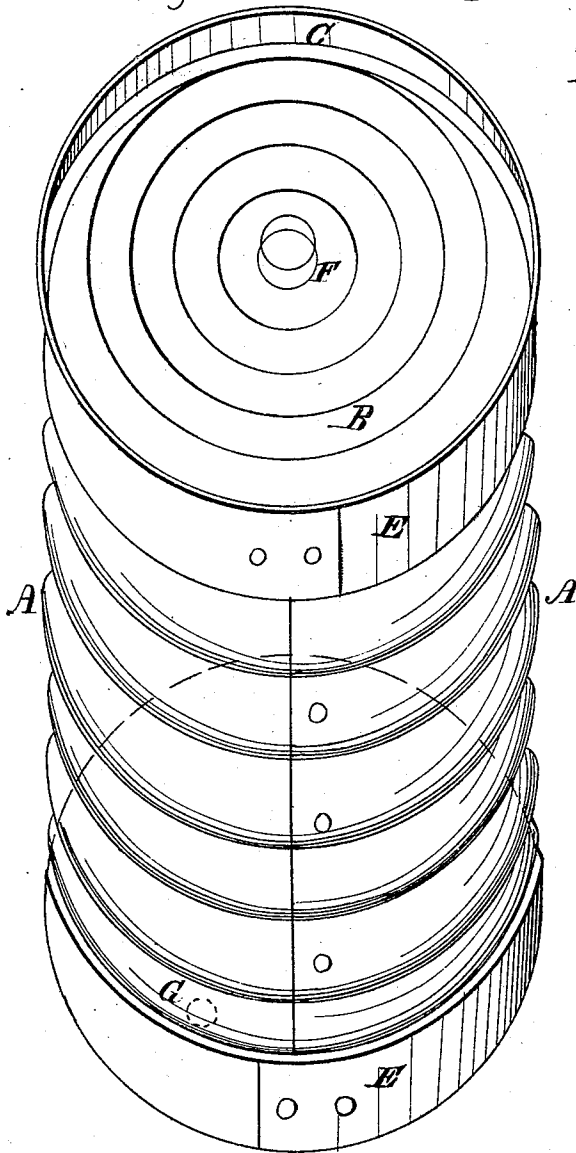

Fig. 1.

Fig. 2.

Witnesses,
J. Fran Selin Reigart
Wm. Heptinstall

Inventors,
John A. Frey
John Allen
Gaston D. Smith

UNITED STATES PATENT OFFICE.

JOHN A. FREY, JOHN ALLEN, AND GASTON D. SMITH, OF WASHINGTON, D. C.

IMPROVEMENT IN BARRELS AND OTHER VESSELS.

Specification forming part of Letters Patent No. 53,970, dated April 17, 1866.

To all whom it may concern:

Be it known that we, JOHN A. FREY, JOHN ALLEN, and GASTON D. SMITH, of the city of Washington and District of Columbia, have invented a new Mode of Making Barrels or Vessels Impervious to Oils or other Fluids; and we do hereby declare the following to be an exact description thereof, reference being had to the accompanying drawings, and to the letters of reference marked thereon, making a part of this specification.

The nature of our invention consists in the construction of a corrugated barrel of any required size, having a flanged head fastened to the barrel by lapping the ends of the barrel over the flange, the flange forming the chine of the barrel, and an iron hoop then driven over tightly.

Figure 1 represents the barrel; Fig. 2, a section of the head.

The barrel being thus firmly made of sheet iron, it is then dipped into a galvanic bath, and galvanized completely inside and out, while all the pores or open places are filled up by the galvanic fluid, and the barrel is then a completely and solidly cemented barrel.

We describe it as follows: The barrel A is made of corrugated sheet-iron, riveted together, and the head B is also corrugated to add strength and firmness to the sheet-iron, the edge of the rim of the head being turned up as a raised flange, C, made by a press or stamp. The head B is then forced into the barrel A to the first flute or corrugation of the barrel and about one-fourth of an inch below the edge D of the barrel. The edge D of barrel is then lapped over the flange C thus closely secured, and the edge of the flange C forming the chine of the barrel, which is more permanently secured by driving iron hoops E over the ends and on or in the body of the barrel.

The bung-hole F is intended to be inserted

in the center of the head B and the tap or faucet hole G' at the side below. A metallic male and female screw are to be attached to the bung-hole and faucet-hole.

After the barrel is completed, instead of using soft solder to tighten and fasten the parts, as usually done in making other barrels, we thrust our barrel thus constructed into a galvanic bath and galvanize the whole, the bath filling up all the parts inside and out, and making the head, barrel, and hoops a solidly compact iron barrel, perfectly impervious to fluids and solid substances, airtight and water-tight, and combining convenience, lightness, and strength, and also free from rust, anti-corrosive, and fire-proof. Although exposed to a great heat, there is no soft solder to melt or break open, and no waste of oil by evaporation, as is usually the case with other barrels, that sustain invariably a loss of three and four gallons of oil in each barrel, and in transportation the bulk of our barrels is much less. In short, the advantages of our oil-barrel are those of perfect safety in every respect.

By the same process we make many other vessels—such as, milk-cans, measures, hogs-heads, tanks, trunks, coffins, soda-fountains, sinks, water-pipe, pumps, gasometers, and boilers.

What we claim as our invention, and desire to secure by Letters Patent, is—

The construction of a metallic barrel or vessel made impervious and solid by galvanizing, as herein described, and for the purpose set forth.

JOHN A. FREY.
JOHN ALLEN.
GASTON D. SMITH.

Witnesses:

J. FRANKLIN REIGART,
EDM. F. BROWN.