

Feb. 22, 1938.

F. ELBAUM

2,109,264

LOCK

Filed Aug. 18, 1937

3 Sheets-Sheet 1

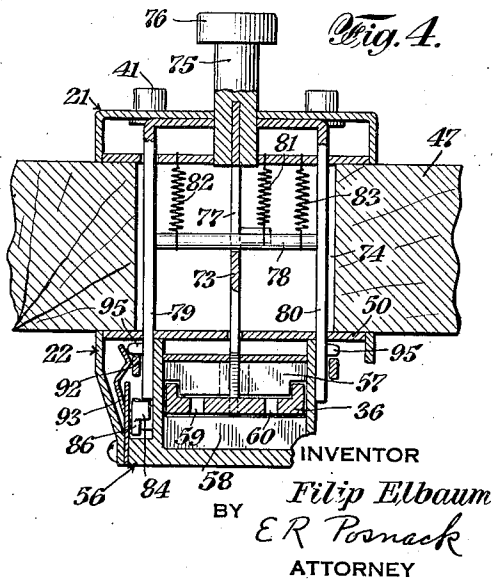
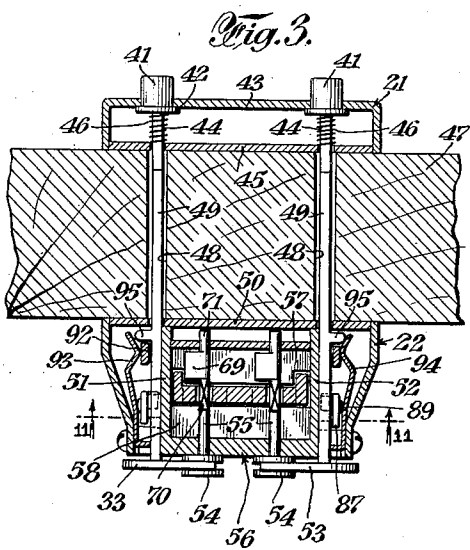
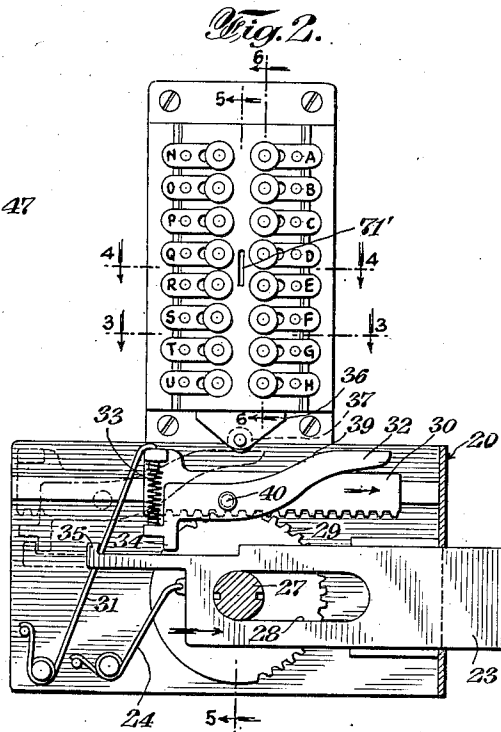
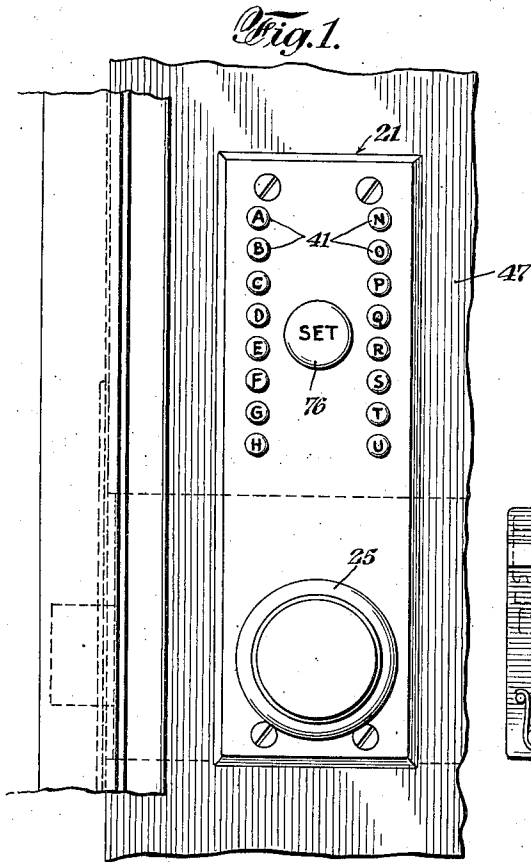

INVENTOR

Filip Elbaum  
BY  
E R Posnack  
ATTORNEY

Feb. 22, 1938.

F. ELBAUM

2,109,264

LOCK

Filed Aug. 18, 1937

3 Sheets-Sheet 2

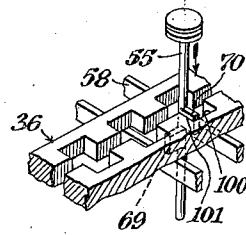
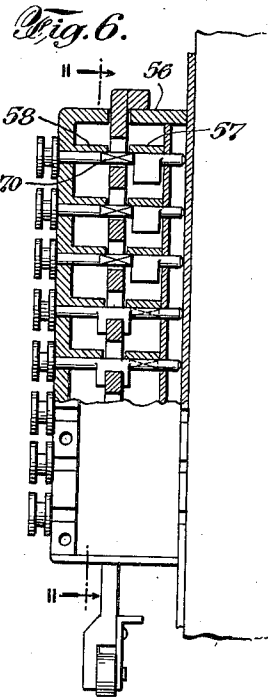
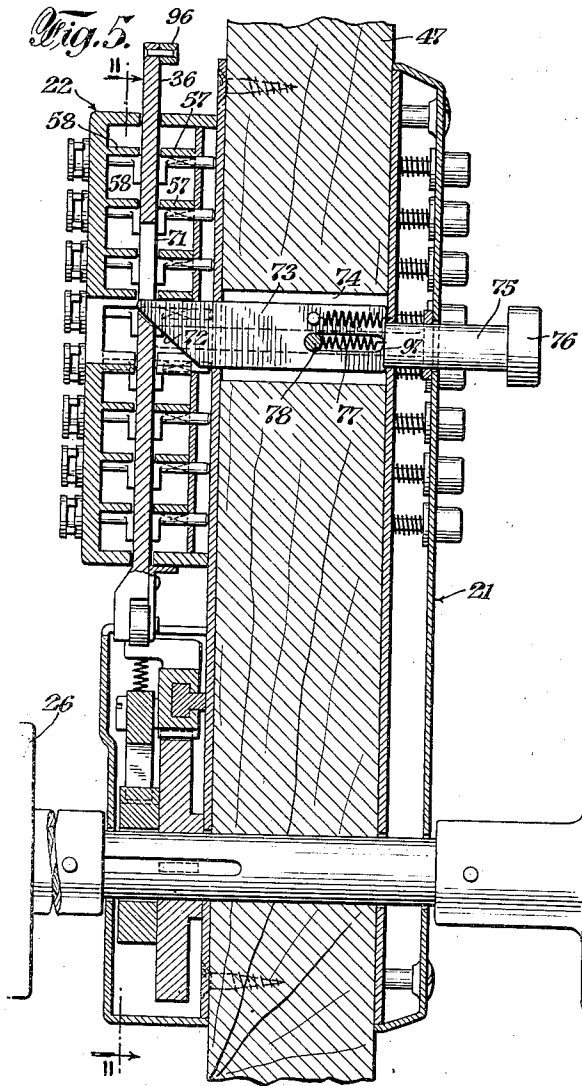

Fig. 10.

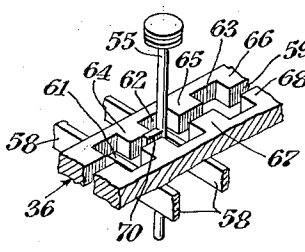

Fig. 7.

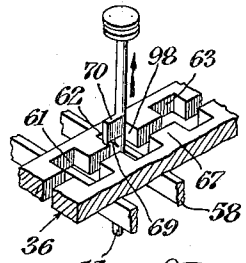

Fig. 8.

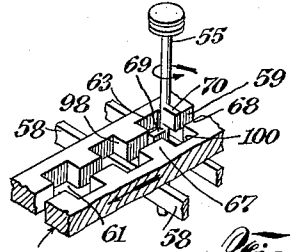

Fig. 9.

INVENTOR  
Filip Elbaum  
BY E. R. Ponnack  
ATTORNEY

Feb. 22, 1938.

F. ELBAUM

2,109,264

LOCK

Filed Aug. 18, 1937

3 Sheets-Sheet 3

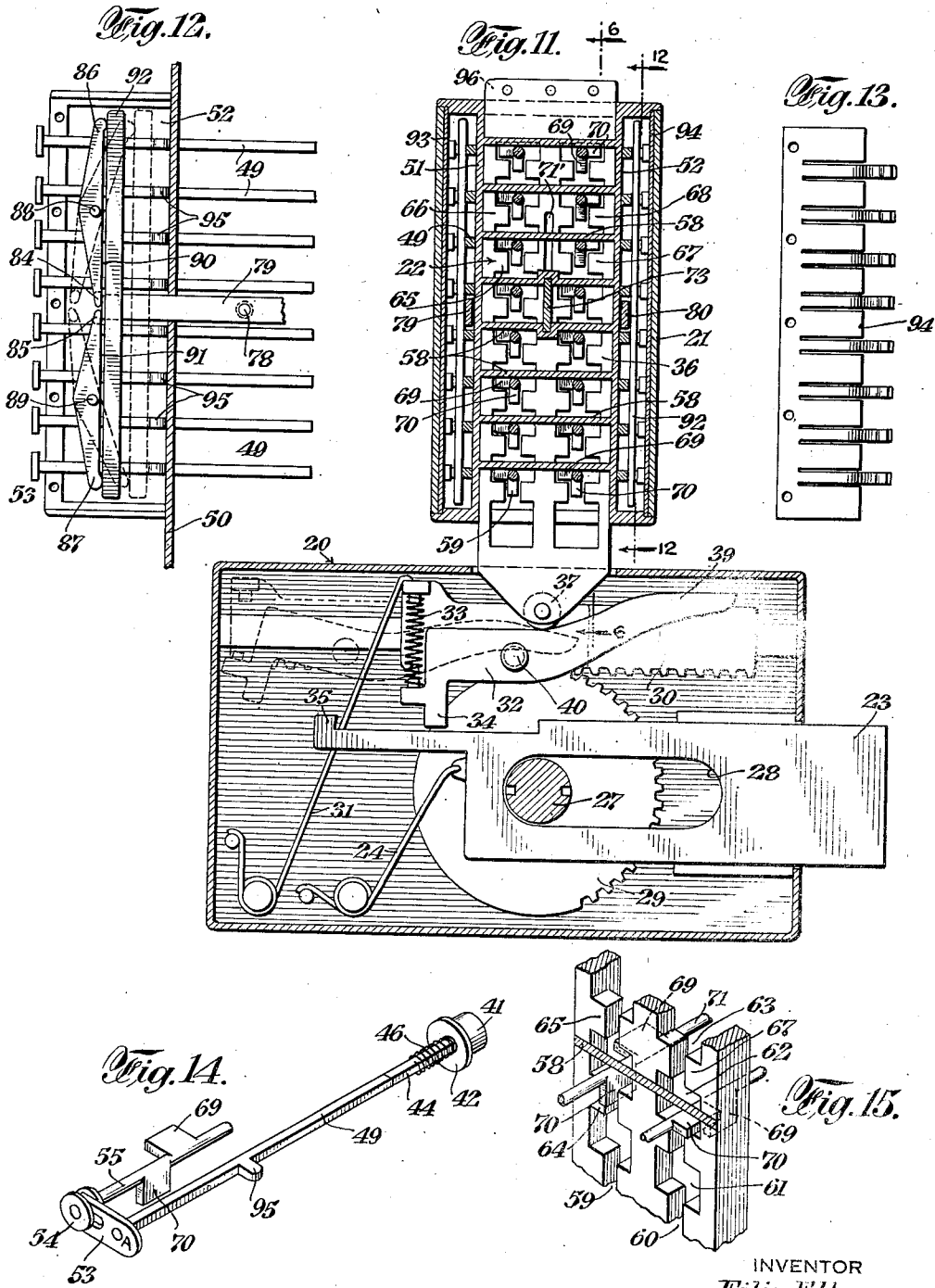

INVENTOR  
*Filip Elbaum*  
BY *E. R. Pomack*  
ATTORNEY

# UNITED STATES PATENT OFFICE

2,109,264

## LOCK

Filip Elbaum, Brooklyn, N. Y., assignor to Julius November, Brooklyn, and Arthur B. Just, Astoria, N. Y.

Application August 18, 1937, Serial No. 159,653

12 Claims. (Cl. 70—298)

This invention relates to keyless locks, particularly of the type adapted to be locked and opened by the manipulation of selected elements such as depressing keys.

5 It is one of the objects of this invention to enable a lock of this type to be constructed with any desired number of manually operable elements so as to effect a wide range of combinations.

10 It is also within the contemplation of my invention to enable the combination in a lock of this class to be readily changed for operative manipulation.

15 Still another object of this invention is to render the locking and unlocking operations relatively simple, and adapted to be readily and quickly effectuated without leaving any visible clue to the setting.

20 And a further object is to obviate the possibility of the set combination being disrupted by an intruder.

Other objects, features and advantages will appear from the drawings and the description hereinafter given.

Referring to the drawings,

25 Figure 1 is a front view of the device containing my invention as applied to a door.

Figure 2 is a rear part sectional view of the device of Figure 1 shown in its open or inoperative position.

30 Figure 3 is a section of Figure 2 taken along line 3—3.

Figure 4 is a fragmentary section of Figure 2 taken along line 4—4.

35 Figure 5 is a longitudinal section of Figure 2 taken along line 5—5.

Figure 6 is a fragmentary longitudinal section of a portion of the device taken substantially along line 6—6 of Figure 2 when in its closed position, and along lines 6—6 of Figures 3 and 11.

40 Figure 7 is a fragmentary perspective of a portion of the locking bar and a plunger pin constituting elements of this invention, when the device is in its open or inoperative position.

45 Figures 8, 9 and 10 are views similar to Figure 7, showing the relative position of the parts during the several steps effectuated by the locking operation.

Figure 11 is a rear sectional view of this invention taken along line 11—11 of Figures 5 and 6, showing the open position of the lock by dot-dash lines.

Figure 12 is a section of Figure 11 taken along line 12—12 thereof, certain of the parts being shown in their projected positions.

55 Figure 13 is a plan view of one of the comb

springs employed in the structure of this invention.

Figure 14 is a perspective of one of the plunger pins used in this invention, and

5 Figure 15 is a fragmentary perspective of the locking bar of this invention showing certain parts in combination therewith.

10 In the drawings (see particularly Figures 2 and 11), the lock casing 20 contains therein the elements of the lock proper, said casing being adjacent the combination casings 21 at the front of the lock and 22 at the rear thereof. The parts of the lock are normally so arranged as to be in an inoperative position, so that only upon an operative setting of the combination will the device be held in a locked position adapted to be opened only by a proper manipulation of the combination keys or buttons, as will be more specifically hereinafter set forth.

20 Within the casing 20 is the slidable locking bolt 23 always yieldably held in its projected or locking position by the spring 24 urging said bolt in the direction of the arrow (see Figure 2). The door knobs 25 and 26 (see Figures 1 and 5) are suitably secured to a shaft 27 which extends through and is in slidable engagement with the walls of the aperture 28 in the bolt. Suitably keyed to the shaft 27 is the gear 29 which is in operative engagement with the rack 30 yieldably urged in the direction of the arrow (see Figure 2) by the suitably mounted spring 31; and pivotally mounted on said rack is the lever 32 yieldably urged into the position shown in Figure 2 by the spring 33. The said rack contains the finger 34 normally adapted to engage the extension 35 of the bolt 23 to effect a retraction thereof, as will be hereinafter described.

40 In the normal or inoperative position of the device, a rotation of the knobs 25 and 26 will cause a counter-clockwise rotation (see Figure 2) of the gear 29, and a consequent movement of the rack 30 in a direction opposite to that shown by the arrow thereon, thereby bringing the finger 34 into engagement with the extension 35 to cause a retraction of the bolt to the position shown by the dotted lines in Figure 2, to fully open the lock. Upon a release of either of said knobs, the springs 24 and 31 will coact with the parts engaged thereby to cause a projection of the bolt 23 to its closed position.

50 It is thus seen from the above description that under normal conditions the finger 34 will always engage the projection 35 upon a turning of the knob, while the device is in its inoperative position. To lock the apparatus, the bar 36 must 55

be brought into its projected position, that is, moved downwardly or towards the lock casing 20, and retained in that position. When this operation is effectuated, in a manner to be later described, the cam portion or roller 37 of said bar will be interposed in the path of the upwardly extending portion 39 of the lever 32; and upon a turning of one of the knobs, the rack 30 and consequently the lever 32 will be moved to the left (Figure 2), as above described. But during the course of this movement, with said bar 36 in its projected position, the portion 39 of the said lever will engage the cam portion 37 of the bar, and the lever will hence be pivotally rotated around its axis 40, thereby retracting the finger 34, against the action of spring 33, out of the path of the extension 35. Upon a continued operative movement of said rack and lever, the finger 34 will hence clear the extension 35, and therefore fail to operatively come into engagement therewith, leaving the bolt 23 in its projected position. It is thus apparent that when the slide bar 36 is in its projected position, an operative manipulation of the knobs 25 or 26 will fail to retract or open the bolt 23, although a rotation of said knobs is not prevented in any manner whatsoever.

The setting of the combination, in the manner to be hereinafter described, permanently maintains the slide bar 36 in its projected position, unless it is released by a proper manipulation of the combination, whereupon a turning of either of the said knobs will enable the bar to be retracted, such as by the engagement of the lever 32 with the cam portion of the said slide bar.

The front casing 21 contains a plurality of apertures through each of which push buttons 41 extend, each button bearing thereon a legend such as the letters of the alphabet, or, if desired, numerals. The inner portions of said push buttons contain flanges 42 abutable with the inner surface 43 of the casing, the stems 44 attached to said buttons extending through suitable holes in the base or wall 45 of said casing 21 and having mounted thereover preferably helical springs 46 normally urging said push buttons outwardly. The door or panel 47 to which the lock is attached contains a plurality of holes 48 extending therethrough, and into which the stems 44 extend. It will be noted that there are as many holes 48 as there are push buttons, the said holes and apertures for the push buttons being in substantial registry. Extending through each of said holes 48 is a rod 49 the forward terminals of which are normally in abutment with the adjacent terminals of the stems 44. The said rods extend rearwardly through suitable apertures in the wall 50 of the rear casing 22, and along the lateral walls 51 and 52 of the inner casing 56, these rods being suitably affixed at their rearmost terminals to the cross bars 53, the latter being mounted over the recessed heads 54 of the pins 55.

The said inner casing 56 contains two sets of spaced walls, (see particularly Figures 5 and 6),—the forward walls 57 and the rearwardly disposed walls 58. Both sets of walls are similarly spaced, said sets being in spaced relation to each other to provide a substantially centrally disposed passageway for the slide bar 36, the bar being adapted to slidably move between the two banks of walls longitudinally of the device a distance equal to the pitch of the walls, that is, the distance between one wall and the next. It is preferred for best operative results that the walls in each set be equally spaced from each other.

The said slide bar 36, in the form of my invention disclosed in the drawings, contains two longitudinal slots 59 and 60, there being spaced recesses, such as the recesses 61, 62 and 63 (see Figures 7 to 10) communicating with said slots. The distance between corresponding portions of the slots is equal to the pitch of the walls 57 and 58. The position of the recesses 61, 62 and 63 and the projecting walls of the bar forming the recesses, such as those identified by the numerals 64, 65, 66, 67 and 68, with respect to the walls 57 and 58 can be readily seen in Figures 6 to 11 inclusive.

The said pins 55 contain on the shanks thereof two flags or lugs 69 and 70, these being in different planes and at right angles to each other. These pins extend through the said slots 59 and 60 of the bars, the uppermost portions 71 thereof being preferably in engagement with the wall 50 of the inner casing 22, to enable them to be properly retained in place.

When the device is in its inoperative or open position, the rearmost lug 70 of each pin is positioned within a longitudinal slot of the bar, such as the slot 59, and extends longitudinally with respect thereto. The forwardly disposed lug 69 is positioned in front of the bar 36, or as shown in Figure 7 (where the parts are inverted), the lug 69 is below the bar and out of the plane thereof,—said lug 69 being disposed transversely with respect to the bar 36, and adjacent one of the walls 58, as well as a corresponding wall 57 not shown in this figure.

The bar 36 contains therein an intermediate slotted aperture 71 extending longitudinally over a distance equal to the pitch of the walls 57 and 58. When the bar is in its retracted position, as shown in Figure 5, the bottom wall thereof is in engagement with the obliquely disposed operative edge 72 of the plunger blade 73 extending transversely through the opening 74 in the door 47. The forward portion of said blade is suitably connected to the plunger shaft 75 which has mounted thereon the exposed plunger button 76. The said blade 73 contains therein an aperture 77 through which extends the transverse member 78 (see Figures 4 and 5) suitably affixed at the opposite ends thereof to the push rods 79 and 80. The plunger blade 73 is normally held in its retracted position, shown in Figures 4 and 5, by means of the spring 81 suitably mounted to the casing 21; and the transverse member 78 together with the push rods 79 and 80 are also held in their retracted positions by the springs 82 and 83.

By referring to Figures 4 and 12 it will be seen that the innermost terminal of each push bar, such as the push bar 79, is in engagement with extensions 84 and 85 positioned at the adjacent terminals of the levers 86 and 87 pivotally mounted at 88 and 89 respectively, said levers preferably containing at the forward portions thereof the flat surfaces 90 and 91 respectively. Positioned adjacent the said flat surfaces is the resetting bar 92, this bar extending longitudinally of the device. Levers such as 88 and 89 and the adjusting bar 92 appear on both sides of the structure, so as to be operatively actuated by both push bars 79 and 80. It should be noted that the resetting bars 92 are preferably loosely mounted, and are held in their forward position, as shown in Figures 3 and 4, by the comb springs 93 and 94, which engage lugs 95 provided on rods 49, to maintain them in their projected positions, see Figure 3. The said resetting bars 92 are also engageable with the

lugs 95 on the rods 49 when operatively actuated in the manner hereinafter described.

In operating this device, the door to which the apparatus is attached is closed, so that the bolt 23 holds it in locked position; and thereafter any desired push buttons are depressed, such as the buttons A, B and C. It should be understood that for the operative manipulation of this apparatus, any number of buttons can be depressed, from one to all contained therein, it being only necessary that note be taken of the buttons that have been depressed. It will also be observed that after the buttons have been depressed, they are returned to their normal positions by the springs 46, so that there is no visible evidence as to which ones have been depressed. The position of the push pin with respect to the bar 36 and the walls such as 58, before the selected buttons are depressed, can be observed in Figure 7. It will be noted that in this position the lug 70 is within the slot 59 and longitudinally disposed with respect thereto, whereas the lug 69 on the pin is positioned at right angles thereto behind (or below) the bar 36 and out of the plane thereof. The said lug 69, however, is positioned in registry with the adjacent recesses, such as 62.

When a selected button 41 is depressed, the stem 44 thereof will cause the rod 49 to move inwardly, thereby carrying with it the cross bar 53 which in turn pulls the pin 55 rearwardly, or as shown in Figure 8 in the direction of the arrow. When this occurs, the lug 70 is brought out of the plane of the bar 36 whereas the lug 69 is brought into the plane of the bar within said recess 62.

The step after depressing the selected push button or buttons is to depress the plunger button 76, against the action of spring 81. This will cause, during the first part of the said depressing operation, the surface 72 of the plunger blade 73 to slidably engage the bottom wall of the slotted aperture 71, and force the bar 36 to be slidably projected downwardly, the amount of movement of said bar being governed by the proportions of the surface 72, the movement being deliberately designed to be equal to the pitch of the walls 57 and 58 as aforesaid. A further downward movement of said bar is prevented by the stop 96 at the top of the bar, this stop coming into abutment with the casing 56 at the end of the stroke. Before the plunger blade 73 reaches the end of its stroke, the forward wall 97 of the aperture 77 engages the transverse member 78 and forces it inwardly, whereby the push rods 79 and 80 are correspondingly moved inwardly to operatively engage the extensions 84 and 85 and cause a pivotal movement of the levers 86 and 87 to the position shown in dotted lines in Figure 12. When this occurs, the opposite extremities of said levers are moved forwardly, causing the adjusting bar 92 to move forwardly to the position shown in dotted lines in Figure 12. Hence any of the lugs 95 on the rods 49 that had moved downwardly due to the depressing operation of the push buttons 41 will be brought back into their original positions.

By referring to Figure 9 the effect of the downward movement of bar 36 will be seen. The bar is caused, by the operative movement of the plunger blade 73, as aforesaid, to move in the direction of the arrow (Figure 9), thereby causing the wall 98 of the recess 62 to engage the lug 69 and cause it to rotate through an angle of 90 degrees, until it is positioned within the

slot 59. Upon the continued operative movement of the bar 36, the said lug 69 will be brought to a position adjacent the recesses 63 and 100, whereas the lug 70 will be now transversely positioned with respect to bar 36, and out of the plane of said bar. When the plunger blade 73 has completed its operative movement, the rods 49 are returned to their normal position by the action of the adjusting bars 92, as above described, thereby causing the cross bars 53 to push the pins 55 back into their normal position. The result of this action is clearly illustrated in Figure 10, which shows the return of the pin 55 to its normal level. In this position, it will be seen that the lug 70 is now positioned within the recess 100, whereas the lug 69 is positioned below the plane of the bar 36. The lug 70 is not only adjacent the wall 101 of the recess 100, but also adjacent one of the walls 58 and the corresponding wall 57. Its position with respect to said walls is clearly shown in Figure 6 where the first three pins are shown in their locking positions.

In this position, the bar is locked against retraction, because of the fact that lug 70 cannot further be rotated, due to its engagement with said walls 57 and 58. Being hence fixed within a recess and adjacent two stationary walls, no movement whatsoever can be imparted to the bar 36. It is of course obvious that if several buttons are depressed, several of such lugs will be similarly disposed to prevent a retraction of the bar. And inasmuch as the bolt 23 cannot be retracted unless the bar 36 is also retracted, it is obvious that the entire mechanism is now fixed in a locked position.

Should it be desired to open the lock, all that need be done is to depress again the very buttons that have been initially depressed in setting the lock. This will cause the rods 49 to again actuate the cross bars 53 and pull out the pins 55 from their set positions. In other words, referring again to Figure 9, the depression of a selected push button to open the combination will cause the corresponding pin 55 to be brought into the position shown in this figure. And it is obvious that in this position both the lugs 69 and 70 are not in an obstructing position, the lug 69 being in the slot 59 and the lug 70 being out of the plane of the bar 36. Hence the said bar can readily be retracted into its normal inoperative position.

If in addition to the selected buttons one or more additional buttons should inadvertently be depressed, in attempting to open the lock, the corresponding additional pins will be pulled out so as to bring the front lug, equivalent to 69, within one of the recesses such as 61, 62 or 63, and in the plane of the bar. For instance, considering Figure 8, and assuming that the pin shown therein was an additional pin inadvertently brought to the position shown in this figure, it is obvious that the lug 69 would be within the recess 98 and hence in an obstructing position to prevent a retraction of bar 36. While it is true that in the position shown in Figure 8 a movement of the bar to the left would cause a rotation of said pin, it is also true that an attempted movement of the bar to the right,—which would be the unlocking or retracting movement,—would merely bring said lug 69 into engagement with the walls such as 57 and 58 to prevent a further rotation thereof. Hence said lug would remain in an obstructing position to prevent a retraction of bar 36.

In the event it is found, upon a depression of

the originally selected buttons, that the lock does not open, it can be assumed that one or more additional buttons had been depressed, possibly by an intruder, after the combination had been set and the device originally locked. All that need therefore be done would be to depress the plunger button 76 to ultimately cause a return of all the pins 55 to their forward positions, in the manner hereinabove described, thereby returning the said additional pins to unobstructing positions, as in Figures 6 and 10. Thereafter, upon a depression of the originally selected buttons, the pins and the lugs thereon will be brought out of their obstructing positions to permit a retraction of the bar 36 and a consequent opening of the lock.

It is of course understood that the various embodiments above described and shown in the drawings are illustrative of my invention and not employed by way of limitation, inasmuch as numerous changes and modifications may be made within the scope of the appended claims without departing from the spirit of this invention.

I claim:

1. In a device of the class described, the combination of a plurality of paired abutting surfaces spaced a pre-determined distance apart, a locking bar slidable between the said pairs of abutting surfaces and provided with a plurality of recesses spaced apart the said pre-determined distance and connected by central, longitudinal slots, a plurality of pins provided with a pair of lugs normal to each other and axially adjustable from an initial position in which one lug is received in a central longitudinal slot and the other lug is clear of the bar, to a projected position in which the first said lug is clear of the bar and the second said lug is received at the forward end of a recess, the said lugs being somewhat wider than the space separating pairs of abutting surfaces, a plurality of keys for axially adjusting certain of the pins to projected position, a latch means for holding the pins of depressed keys in projected positions, and a manipulative means for moving the bar to locking position, and for rotating the projected pins to turn the first said lugs to a position normal to the central, longitudinal lugs and the second said lugs, in alignment therewith, the said bar movement presenting the forward end of the succeeding recesses to the first said lugs, and the said manipulative means being connected to the said latch means to return the projected pins to initial position, the first said lugs of the projected pins entering the forward ends of the said succeeding recesses whereby return movement of the bar is prevented by the abutment of the said lugs with the said abutting surfaces.

2. In a device of the class described, the combination of a locking bar provided with a plurality of spaced recesses connected by central longitudinal slots, a plurality of pins provided with a pair of lugs normal to each other and axially adjustable from an initial position in which one of the said pair of lugs is received in a said central longitudinal slot and the other lug is clear of the said bar, to a projected position in which the first said lug is clear of the bar and the second said lug is received at the forward end of a recess, latch means for maintaining the pins in projected position, and a manipulative means for moving the bar to locking position and for rotating the latched projected pins by their lugs received in the recesses of the bar and

for releasing the projected pins to return them to their initial but turned position.

3. In a device of the class described, the combination of a locking bar provided with a plurality of spaced recesses connected by central longitudinal slots, and a plurality of pins provided with a pair of lugs normal to each other and axially adjustable from an initial position in which one of the said pair of lugs is received in a said central longitudinal slot and the other lug is clear of the said bar, to a projected position in which the first said lug is clear of the bar and the second said lug is received at the forward end of a recess, whereby the said locking bar may be moved with the pins in either their said initial or projected positions.

4. The combination of claim 3 wherein the said pins are capable of rotational adjustment, further provided with a manipulative means for moving the said bar to locking position whereby the projected pins will be rotated by their lugs received in the recesses of the bar.

5. In a device of the class described, the combination of a plurality of paired abutting surfaces, each pair being spaced a pre-determined distance from each other and comprising an upper and lower abutting surface, a locking bar slidable between the said pairs of abutting surfaces and provided with a plurality of recesses spaced from each other the said pre-determined distances and connected by a central longitudinal slot, a plurality of pins provided with a pair of lugs normal to each other and axially movable to adjust the lugs relatively to the said recesses and slots and the said abutting surfaces and a plurality of keys for axially moving certain of the pins.

6. In a device of the class described, the combination of a plurality of paired abutting surfaces spaced a pre-determined distance from each other, a locking bar slidable relatively to the said surfaces and provided with a plurality of recesses spaced the said pre-determined distance and provided with a plurality of longitudinal slots, a plurality of pins provided with lugs and rotationally and axially movable to adjust the lugs relatively to the said recesses and slots and the said abutting surfaces, a plurality of keys for axially moving certain of the pins and a manipulative means for moving the locking bar to rotationally adjust the said pins.

7. In a device of the class described, the combination of a locking bar provided with a plurality of spaced recesses connected by central longitudinal slots, a plurality of pins provided with a pair of lugs normal to each other, one lug receivable in the said recesses and the other receivable in the said central slots, keys individual to the said pins effective upon depression to adjust the said lugs relatively to the said recesses and slots, and a manipulative means for moving the said locking bar and for further adjusting the lugs of those pins which have been adjusted by the said key depression, relatively to the said recesses and slots of the said locking bar.

8. In a device of the class described, the combination of a locking bar provided with spaced recesses connected by central longitudinal slots, a plurality of abutting surfaces associated with the said recesses and slots, a plurality of pins provided with a pair of lugs in co-operative association with the said recesses and slots of the locking bar and with the said abutting surfaces, keys individual to the said pins and a manipulative means for moving the locking bar, the de-

pression of any key or keys and the movement of the said bar adjusting the position of the said pin lugs relatively to the recesses and slots of the bar and to the said abutting surfaces.

5 9. In a device of the class described, the combination of a locking bar provided with a plurality of spaced recesses connected to each other by central longitudinal slots, a plurality of pins provided with a pair of lugs normal to each other,  
10 one lug receivable in the said recesses and the other receivable in the said central slots and keys individual to the said pins effective upon depression to adjust the said lugs relatively to the said recesses and slots.

15 10. In a device of the class described, the combination of a movable member, a manipulative means for moving the said member to locking position, and a plurality of keys the depression of any number or combination of which prior to  
20 the operation of the said manipulative means

maintains the said member in locking position and the depression of the same combination of keys subsequent to the operation of the said manipulative means and locking of the said member, releases the latter from locking position.

11. The combination of claim 10 wherein the depression of any combination of keys other than those originally depressed to lock the said member, will prevent the unlocking thereof by the subsequent depression of the original combination of keys, whereby tampering of the device  
10 may be detected.

12. The combination of claim 10 wherein the operation of the said manipulative means is required subsequently to the depression of a combination of keys other than the original locking  
15 combination, before the depression of the latter combination of keys will release the locked member.

FILIP ELBAUM. 20