



US 20120001492A9

(19) **United States**  
(12) **Patent Application Publication**  
**Cook et al.**

(10) **Pub. No.: US 2012/0001492 A9**  
(48) **Pub. Date: Jan. 5, 2012**  
**CORRECTED PUBLICATION**

(54) **INCREASING THE Q FACTOR OF A RESONATOR**

(65) US 2009/0051224 A1 Feb. 26, 2009

**Related U.S. Application Data**

(75) Inventors: **Nigel P. Cook**, El Cajon, CA (US);  
**Lukas Sieber**, Olten (CH);  
**Hanspeter Widmer**, Wohlenschwil (CH)

(63) Continuation-in-part of application No. 12/018,069, filed on Jan. 22, 2008.

(60) Provisional application No. 60/954,941, filed on Aug. 9, 2007, provisional application No. 60/904,628, filed on Mar. 2, 2007.

(73) Assignee: **NIGELPOWER, LLC**, San Diego, CA (US)

**Publication Classification**

(21) Appl. No.: **12/189,433**

(51) **Int. Cl.**  
**H02J 17/00** (2006.01)

(22) Filed: **Aug. 11, 2008**

(52) **U.S. Cl.** ..... **307/104**

**Prior Publication Data**

(15) Correction of US 2009/0051224 A1 Feb. 26, 2009  
See (63) and (60) Related U.S. Application Data.

(57) **ABSTRACT**

A wireless powering and charging system is described. The antennas can be high q loop antennas. The antennas can use coupling between a first part and a second part.

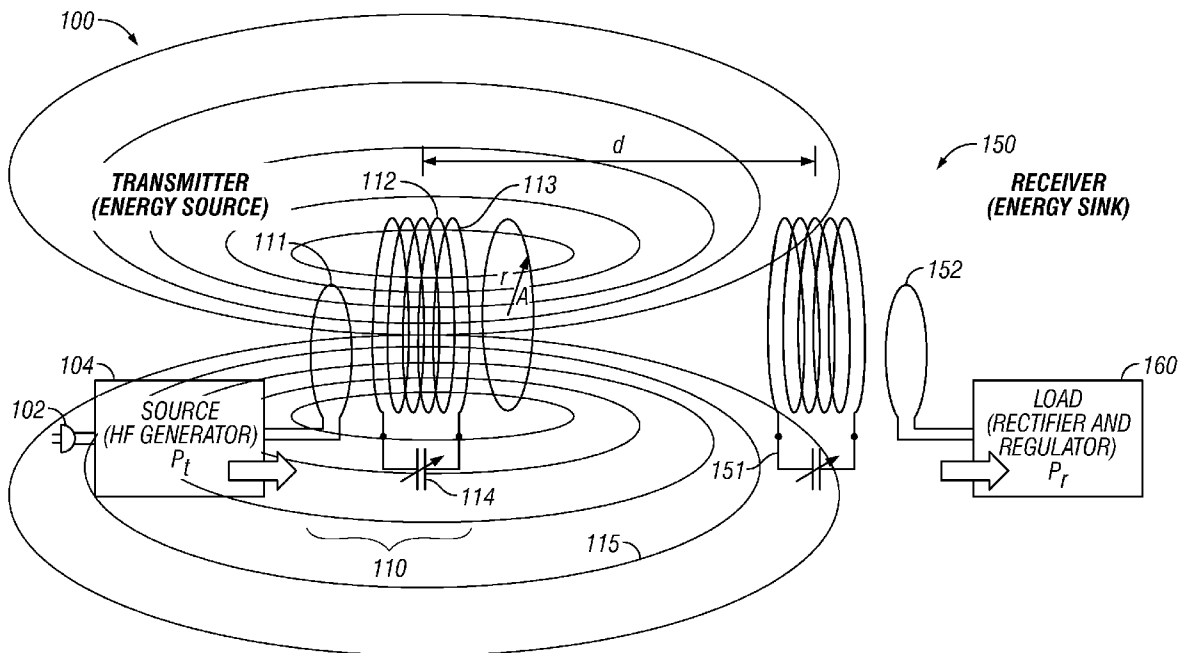

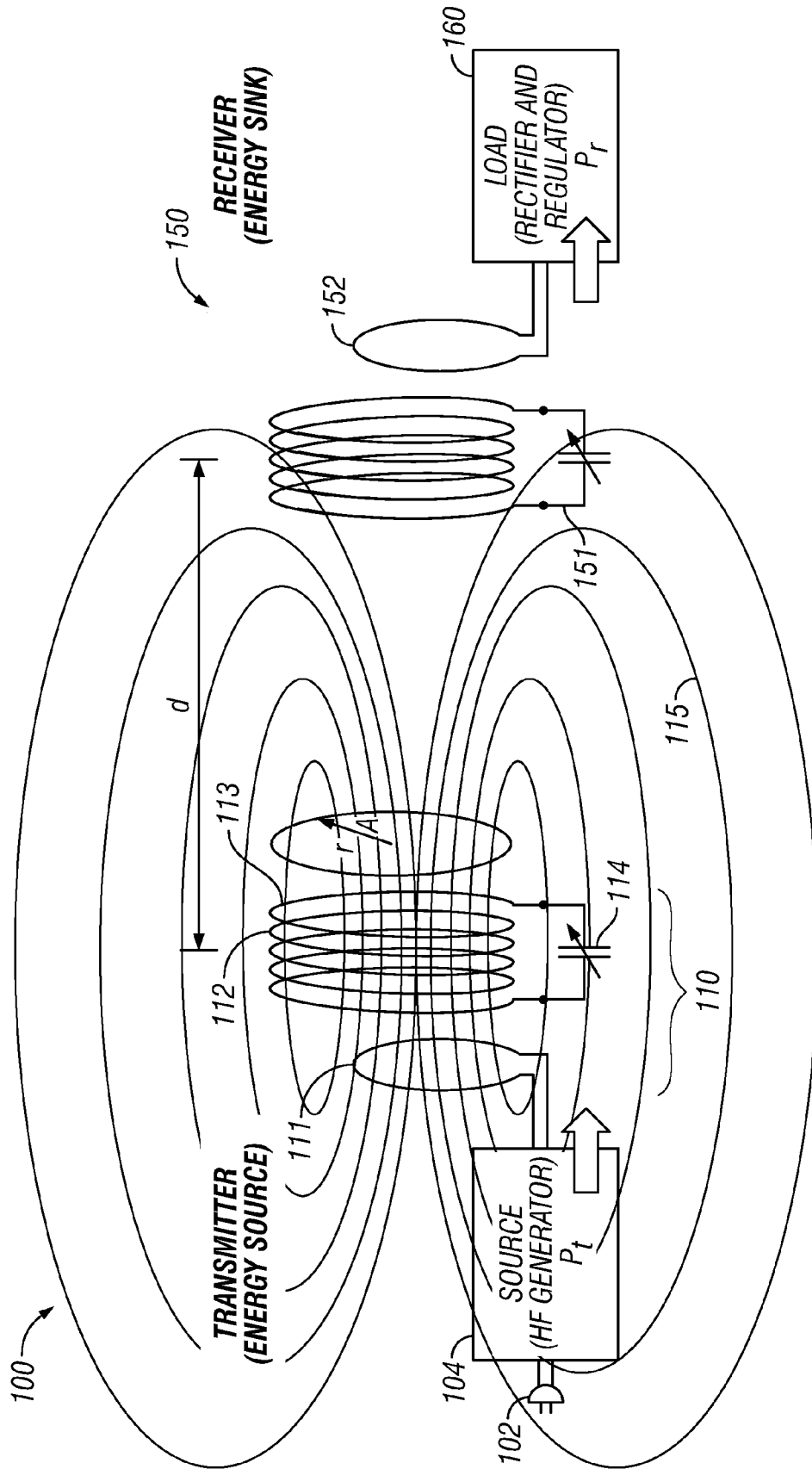

FIG. 1

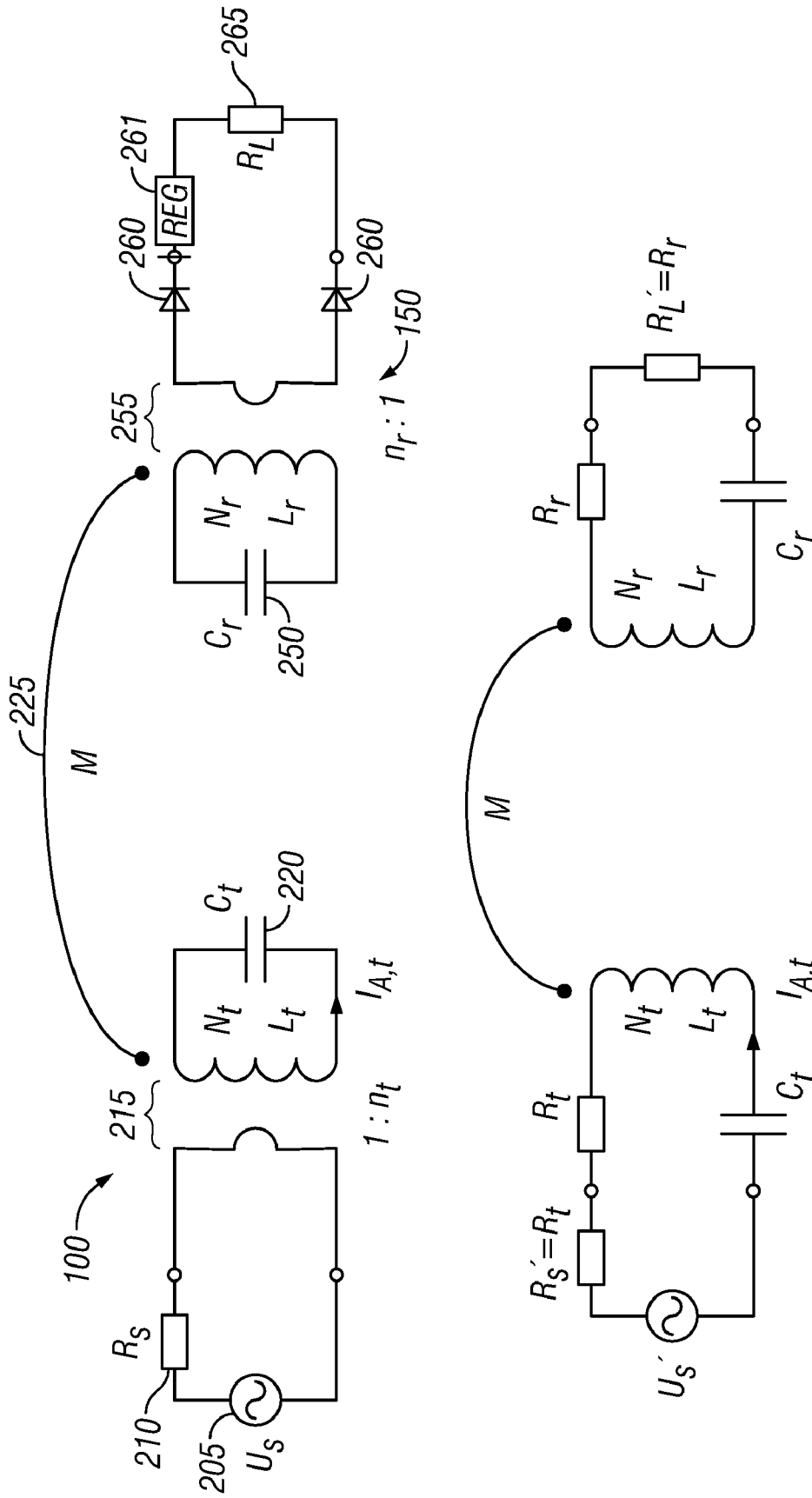

FIG. 2

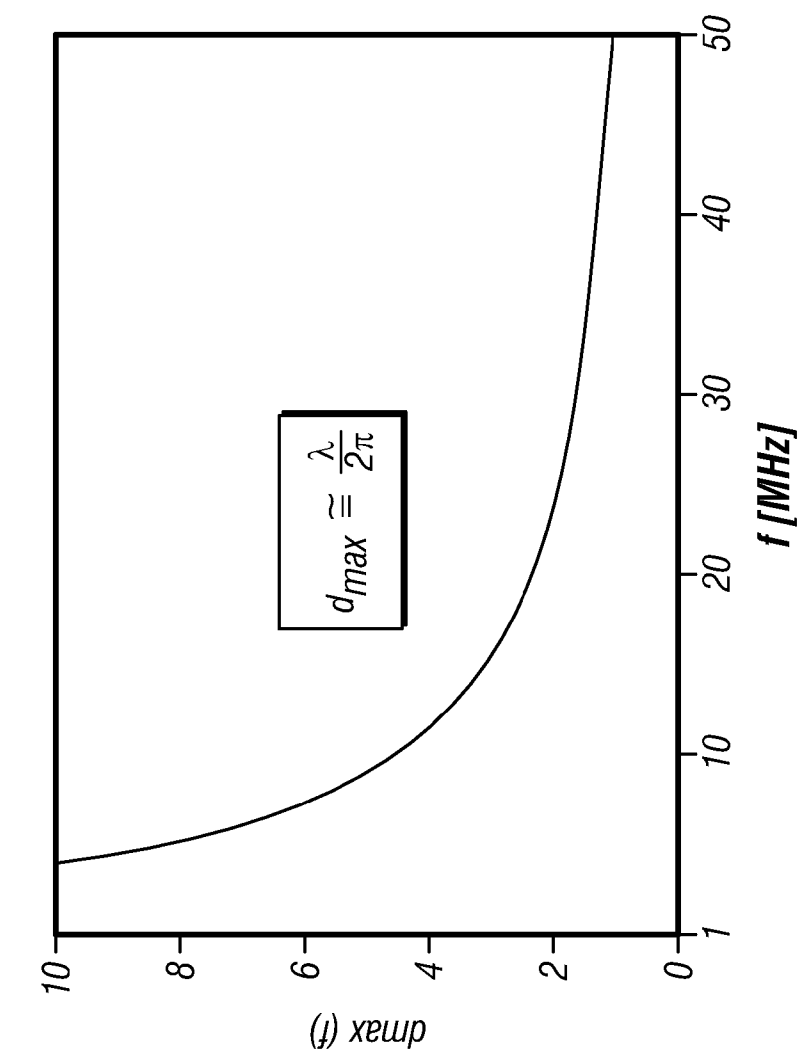
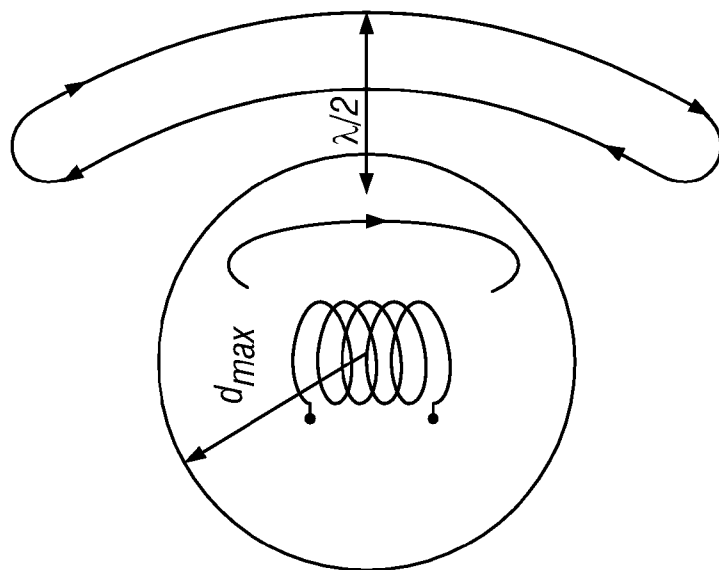

FIG. 3



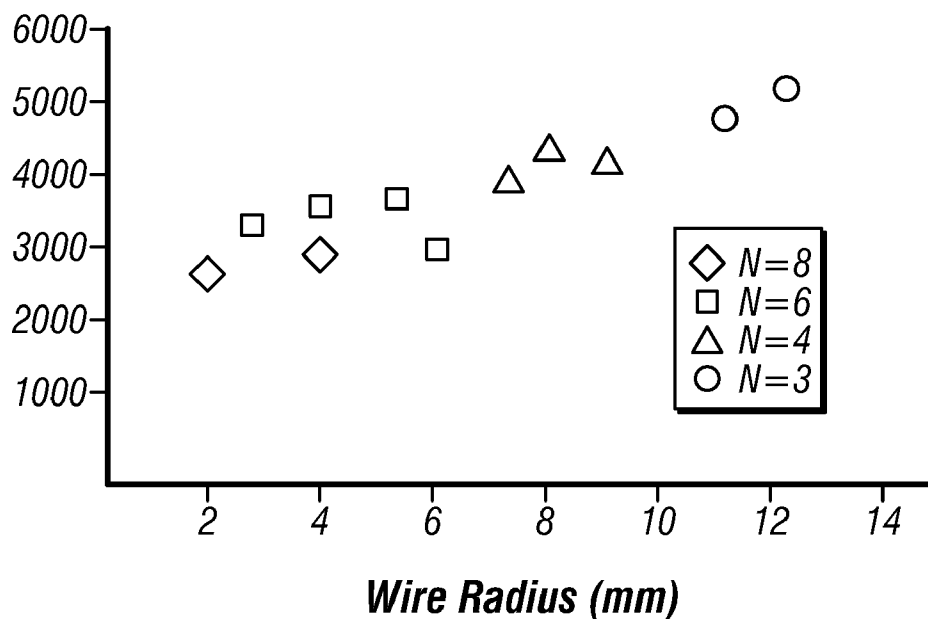

FIG. 4

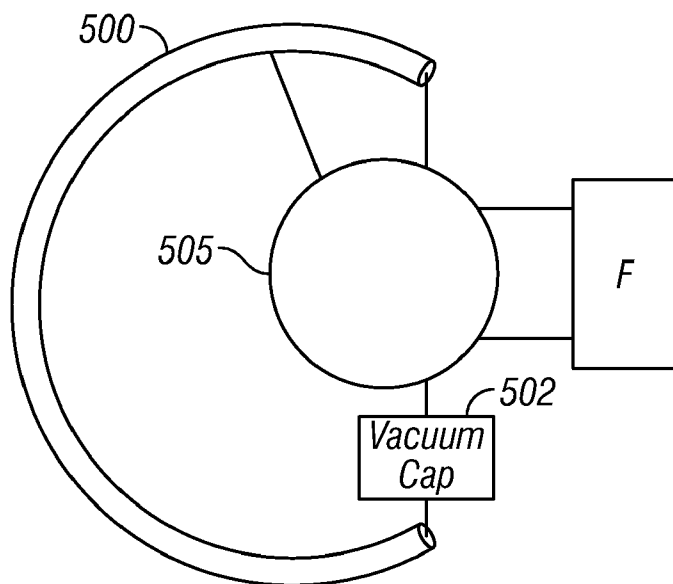

FIG. 5

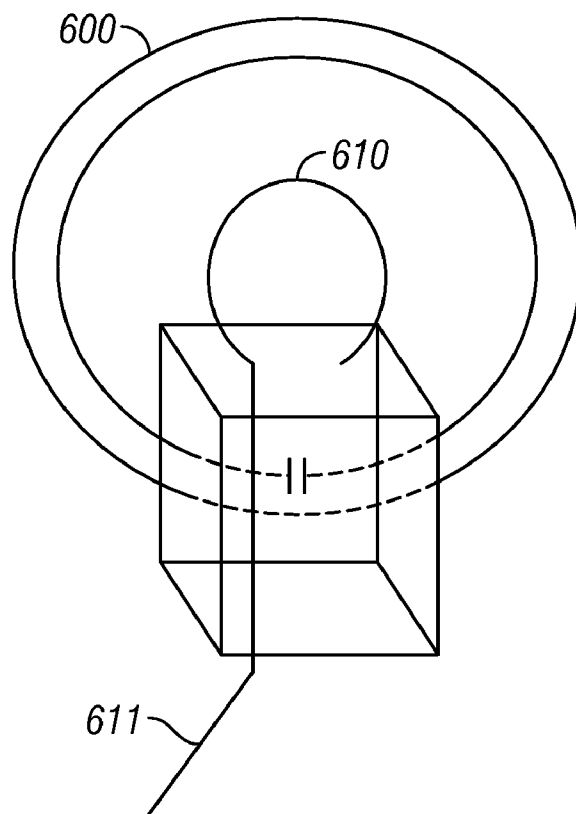

FIG. 6

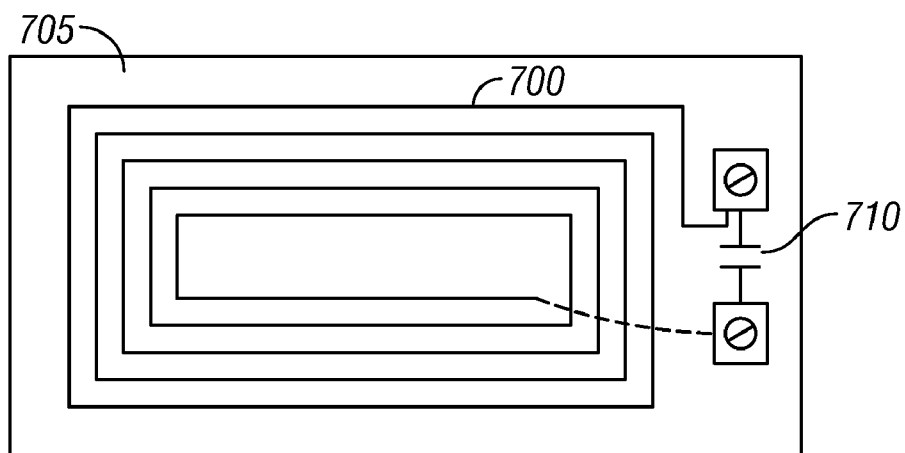

FIG. 7

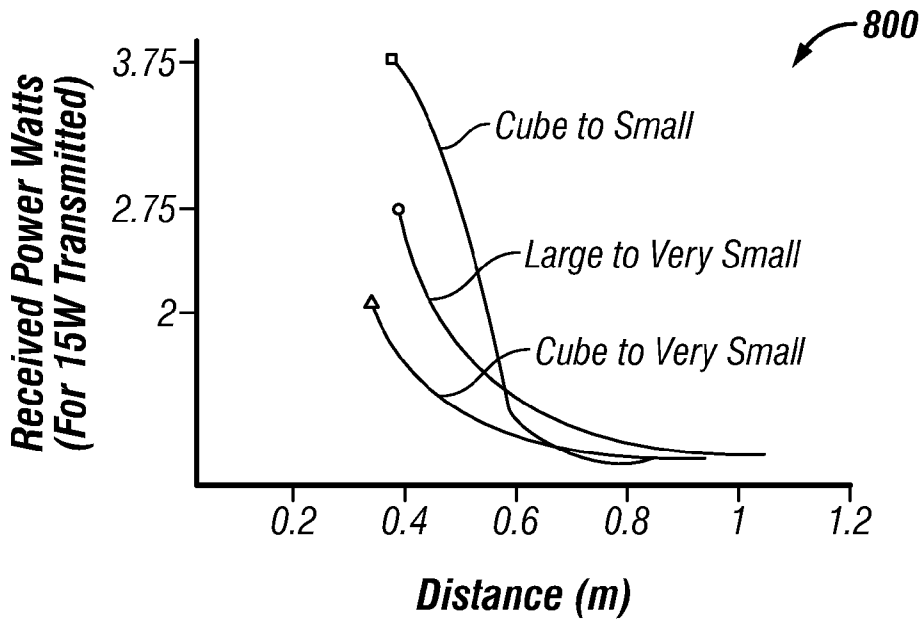

FIG. 8

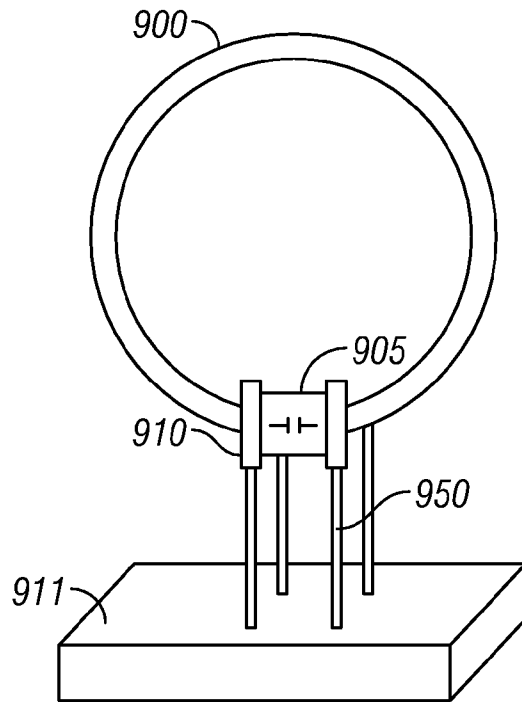

FIG. 9

## INCREASING THE Q FACTOR OF A RESONATOR

[0001] This application claims priority from provisional application No. 60/954,941, filed Aug. 9, 2007, the entire contents of which are herewith incorporated by reference.

### BACKGROUND

[0002] It is desirable to transfer electrical energy from a source to a destination without the use of wires to guide the electromagnetic fields. A difficulty of previous attempts has been low efficiency together with an inadequate amount of delivered power.

### SUMMARY

[0003] The present application teaches a wireless electrical energy transfer, and teaches specific techniques for that energy transfer including specific antennas, and specific materials for the antennas.

### BRIEF DESCRIPTION OF THE DRAWINGS

[0004] These and other aspects will now be described in detail with reference to the accompanying drawings, wherein:

[0005] FIG. 1 shows a block diagram of a magnetic wave based wireless power transmission system;

[0006] FIG. 2 illustrates circuit diagrams of the circuits in the FIG. 1 diagram;

[0007] FIG. 3 illustrates an exemplary near field condition plot;

[0008] FIG. 4 illustrates a graph between Q factors that were experimentally found between different antennas;

[0009] FIG. 5 illustrates a large one turn antenna;

[0010] FIG. 6 illustrates a cube-shaped two turn antenna;

[0011] FIG. 7A illustrates a very small receiver antenna;

[0012] FIG. 8 illustrates some exemplary power transfer operations; and

[0013] FIG. 9 illustrates a large transmit antenna with a capacitor holder including plural different standoffs.

### DETAILED DESCRIPTION

[0014] The general structure and techniques, and more specific embodiments which can be used to effect different ways of carrying out the more general goals, are described herein.

[0015] The present application describes transfer of energy from a power source to a power destination via electromagnetic field coupling. Embodiments describe techniques for new coupling structures, e.g., transmitting and receiving antennas.

[0016] An embodiment is shown in which the main coupling occurs via inductive coupling, using primarily a magnetic field component. In the embodiment shown in FIG. 1, for example, energy is formed as a stationary magnetic wave in the area of the transmitting antenna 110. The energy that is produced is at least partly a non-radiative, stationary magnetic field. The produced field is not entirely magnetic, nor entirely stationary, however at least a portion is stationary and magnetic. Unlike a traveling electromagnetic wave, which would continue propagating into space and have its energy wasted, at least a portion of the stationary magnetic wave remains in the area of the transmitting antenna and is rendered usable by the disclosed techniques.

[0017] Other embodiments may use similar principles of the embodiments and are equally applicable to primarily electrostatic and/or electrodynamic field coupling as well. In general, an electric field can be used in place of the magnetic field, as the primary coupling mechanism.

[0018] One aspect of the embodiment is the use of a high efficiency that comes from increasing the so-called Q factor of the coupling structures (primarily the antennas) at the self-resonant frequency used for the sinusoidal waveform of the electromagnetic field, voltage or current used. The present inventors have discovered that the efficiency and amount of power is superior for a system which uses a single, substantially un-modulated sine wave. In particular, the performance is superior to a wide-band system which attempts to capture the power contained in a wideband waveform or in a plurality of distinct sinusoidal waveforms of different frequencies. Other embodiments may use less pure waveforms, in recognition of the real-world characteristics of the materials that are used. Techniques are described herein which enable small resonant antennas with relatively high Q factors.

[0019] The Q of a resonant device is the ratio of the resonant frequency to the so-called “three dB” or “half power” bandwidth of the resonant device. While there are several “definitions,” all are substantially equivalent to each other, to describe Q in terms of measurements or the values of resonant circuit elements.

[0020] A basic embodiment is shown in FIG. 1. A power transmitter assembly 100 receives power from a source, for example, an AC plug 102. A frequency generator 104 is used to create a signal at a frequency (Pt) and to couple that frequency to an antenna 110, here a resonant antenna. The antenna 110 includes an coupling loop 111, which is inductively and non-contactively coupled to a high Q resonant antenna part 112.

[0021] The resonant antenna includes a number N of coil loops 113 each loop having a radius  $R_A$ . A capacitor 114, here shown as a variable capacitor, is in series with the coil 113, forming a resonant loop. In the embodiment, the capacitor is a totally separate structure from the coil, but in certain embodiments, the self capacitance of the wire forming the coil can form the capacitance 114.

[0022] The frequency generator 104 can be preferably tuned to the antenna 110, and also selected for FCC compliance.

[0023] This embodiment uses a multidirectional antenna as the antenna part 112. 115 shows the energy as output in all directions. The antenna 100 is non-radiative, in the sense that much of the output of the antenna is not electromagnetic radiating energy, but is rather a magnetic field which is more stationary. Of course, part of the output from the antenna will in fact radiate.

[0024] Another embodiment may use a radiative antenna.

[0025] A receiver 150 includes a receiving antenna 155 placed a distance d away from the transmitting antenna 110, but not coupled thereto. The receiving antenna is similarly a high Q resonant coil antenna having a coil part and capacitor 151, coupled to an inductive coupling loop 152. The capacitor 151 may be variable for tuning. As in the transmitting antenna, the coupling loop 152 is physically separate from the main part of the antenna. The output of the coupling loop 152 is rectified in a rectifier 160, and applied to a load. That load can be any type of load, for example a resistive load such as a



light bulb, or an electronic device load such as an electrical appliance, a computer, a rechargeable battery, a music player or an automobile.

**[0026]** The energy can be transferred through either electrical field coupling or magnetic field coupling, although magnetic field coupling is predominantly described herein as an embodiment.

**[0027]** Electrical field coupling provides an inductively loaded electrical dipole that is an open capacitor or dielectric disk. Extraneous objects may provide a relatively strong influence on electric field coupling. Magnetic field coupling may be preferred, since it extraneous objects have the same magnetic properties as “empty” space.

**[0028]** The embodiment describes a magnetic field coupling using a capacitively loaded magnetic dipole. Such a dipole is formed of a wire loop forming at least one loop or turn of a coil, in series with a capacitor that electrically loads the antenna into a resonant state.

**[0029]** FIG. 2 shows an equivalent circuit for the energy transfer. The transmit circuit **100** is a series resonant circuit with RLC portions that resonate at the frequency of the high frequency generator **205**. The transmitter includes a series resistance **210**, and inductive coil **215**, and a variable capacitance **220**. This produces the magnetic field *M* which is shown as magnetic lines of force **225**.

**[0030]** The signal generator **205** has an internal resistance that is preferably matched to the transmit resonator’s resistance at resonance by the inductive loop. This allows transferring maximum power from the transmitter to the receiver antenna.

**[0031]** The receive portion **150** correspondingly includes a capacitor **250**, transformer coil **255**, rectifier **260**, and regulator **261**, to provide a regulated output voltage. The output is connected to a load resistance **265**. FIG. 2 shows a half wave rectifier, but it should be understood that more complex rectifier circuits can be used. The impedance of the rectifier **260** and regulator **261** is matched to the resistance of the receive resonator at resonance. This enables transferring a maximum amount of power to the load. The resistances take into account skin effect/proximity effect, radiation resistance, as well as both internal and external dielectric loss.

**[0032]** A perfect resonant transmitter will ignore, or minimally react with, all other nearby resonant objects having a different resonant frequency. However, when a receiver that has the proper resonant frequency encounters the field of the transmitting antenna **225**, the two couple in order to establish a strong energy link. In effect, the transmitter and receiver operate to become a loosely coupled transformer.

**[0033]** The inventors have discovered a number of factors that improve the transfer of power from transmitter to receiver.

**[0034]** Q factor of the circuits, described above, can assist with certain efficiencies. A high Q factor allows increased values of current at the resonant frequency. This enables maintaining the transmission over a relatively low wattage. In an embodiment, the transmitter Q may be 1400, while the receiver Q is around 300. For reasons set forth herein, in one embodiment, the receiver Q may be much lower than the transmitter Q, for example ¼ to ½ the transmitter Q. However, other Q factors may be used.

**[0035]** High Q has a corresponding disadvantage of narrow bandwidth effects. Such narrow bandwidth have typically been considered as undesirable for data communications. However, the narrow bandwidth can be used in power trans-

fer. When a high Q is used, the transmitter signal is sufficiently pure and free of undesired frequency or phase modulation to allow transmission of most of its power over this narrow bandwidth.

**[0036]** For example, an embodiment may use a resonant frequency of 13.56 MHz and a bandwidth of around 9 kHz. This is highly usable for a substantially un-modulated fundamental frequency. Some modulation on the fundamental frequency may be tolerated or tolerable, however, especially if other factors are used to increase the efficiency. Other embodiments use lower Q components, and may allow correspondingly more modulation on the fundamental.

**[0037]** An important feature may include use of a frequency which is permitted by regulation, such as FCC regulations. The preferred frequency in this exemplary embodiment is 13.56 MHz but other frequencies may be used as well.

**[0038]** In addition, the capacitors should be able to withstand high voltages, for example as high as 4 kV, since the resistance may be small in relation to the capacitive reactance. A final important feature is the packaging: the system should be in a small form factor.

**[0039]** One aspect of improving the coupling between the transmit and receive antenna is to increase the Q of the antenna. The efficiency of power transfer  $\eta$  may be expressed as

$$\eta(d) \cong \frac{r_{A,t}^3 \cdot r_{A,r}^3 \cdot Q_t \cdot Q_r}{16d^6}$$

**[0040]** Note that this increases as the cube of the radius of the transmitting antenna, the cube of the radius of the receiving antenna, and decreases to the sixth power of the distance. The radii of the transmit and receive antennas may be constrained by the application in which they are used. Accordingly, increasing the Q in some applications may be a preferred way of increasing the efficiency.

**[0041]** FIG. 4 illustrates a graph between Q factors that were experimentally found between different antennas. This graph shows that, for a given frequency, the Q factors increases when the resonator coil of the resonator has fewer turns.

**[0042]** The inventors discovered an optimum antenna that may exist with a single turn loop, provided that the loss resistance of the material, e.g., the wire or tubing, forming the loop is maintained sufficiently low.

**[0043]** An embodiment illustrated in FIG. 5 uses a single turn antenna **500** formed of a relatively thick conductor material, driven by a smaller coil **505**. The antenna **500** is provided in series with a capacitive loading, here a vacuum capacitor **502**. In an embodiment, the single turn antenna is formed of copper tubing. The vacuum capacitors which have a very high Q factor and can also handle a very high voltage. Vacuum capacitors on the order of 200 pf can be used, for example. This antenna may have a low impedance, thereby enabling high current and high magnetic field. It may also provide low RF voltage and thus low electric stray field and lower susceptibility to loss from extraneous objects.

**[0044]** An embodiment may use a 6 mm copper tube coil resonator and a loop radius of 9 inches. Another embodiment may use a 30 mm copper tube. Preferably the copper tube is at least 1 inch in diameter, used with a vacuum capacitor that has a very high Q. A vacuum capacitor may have a Q of 1000.

[0045] An issue with the single turn loop antenna is that it must have a relatively large diameter.

[0046] A compromise size may be formed from a two-turn antenna, which is shown in FIG. 6. The two-turn antenna can have a 3 1/2 inch diameter coil 600. FIG. 6 illustrates a plastic housing, using a vacuum capacitor integrated directly on the antenna. The transmission inducement coil 610 is also mounted on the housing, connected to a cable 611.

[0047] The receiver antennas can also be important. FIG. 7 illustrates an exemplary receiver antenna including a plurality of turns of material 700 mounted on a substrate 705. A capacitor 710 is attached to the coil material 700.

[0048] It was found that the substrate that is used as a base may itself be important in setting the Q. Table 1 illustrates some exemplary electrical properties (including Quality factor) for different substrates

TABLE 1

Electric properties of different substrate materials			
Material	Loss factor (tan δ)	Quality Factor (1/tan δ)	Dielectric constant ε <sub>r</sub>
FR4	0.0222	45	3.95
PVC	0.0063	160	1.10
Rubalit 710	0.0013	770	1.00
PTFE (Teflon)	0.0011	910	1.20

This data is valid for frequencies in the range from 10-20 MHz only

[0049] Table 1: Electrical Properties of Different Substrate Materials

[0050] The FIG. 7 antenna is a six turn antenna, and has a quality factor of around 400. According to an embodiment, a high quality factor material, such as PTFE, is used as the substrate. Another aspect is the limits which can be used on these antennas. Table 2 illustrates the likely limits for the application.

FCC LIMITS FOR MAXIMUM PERMISSABLE EXPOSURE (MPE)				
Frequency Range (MHz)	Electric Field Strength (E) (V/m)	Magnetic Field Strength (H) (A/m)	Power Density (S) (mW/cm <sup>2</sup> )	Averaging Time (minutes)
(A) Limits for Occupational/Controlled Exposure				
0.3-3.0	614	1.63	(100)*	6
3.0-30	1842/f	4.89/f	(900/f)*	6
30-300	61.4	0.163	1.0	6
300-1500	—	—	f/300	6
1500-100,000	—	—	5	6
(B) Limits for General Population/Uncontrolled Exposure				
0.3-1.34	614	1.63	(100)*	30
1.34-30	824/f	2.19/f	(180/f)*	30
30-300	27.5	0.073	0.2	30
300-1500	—	—	f/1500	30
1500-100,000	—	—	1.0	30

f = frequency in MHz

\*Plane-wave equivalent power density

NOTE 1:

See Section I for discussion of exposure categories.

NOTE 2:

The averaging time for General Population/Uncontrolled exposure to fixed transmitters is not applicable for mobile and portable transmitters. See 47 CFR §§2.1891 and 2.2863 on source-based time-averaging requirements for mobile and portable transmitters.

[0051] Some exemplary power transfer operations are illustrated in FIG. 8. The receiver antenna can be small or “very small”. The transmitting antenna can be the type “large”, shown in FIG. 5, or the “cube” type shown in FIG. 6. FIG. 8 illustrates the power for a transmit power of 15 W. The horizontal line 800 in FIG. 8 illustrates 1/2 watt being received for a 15 watt transmission. Anything above this amount may be considered acceptable.

[0052] FIG. 9 illustrates the large transmit antenna, using 30 mm tubing 900, and a vacuum capacitor 905 integrated between the portions of the antenna. The capacitor 905 is mounted within a capacitor holder structure 910 which is welded or soldered between ends of the loop. A capacitor holder includes plural different standoffs 950, within which, or attached to which, the capacitors can be located. The substrate 911 in FIG. 9 may be a high-q material, as described above.

[0053] Although only a few embodiments have been disclosed in detail above, other embodiments are possible and the inventors intend these to be encompassed within this specification. The specification describes specific examples to accomplish—more general goal that may be accomplished in another way. This disclosure is intended to be exemplary, and the claims are intended to cover any modification or alternative which might be predictable to a person having ordinary skill in the art. For example, other sizes, materials and connections can be used. Although the coupling part of the antenna is shown as a single loop of wire, it should be understood that this coupling part can have multiple wire loops.

[0054] Also, the inventors intend that only those claims which use the-words “means for” are intended to be interpreted under 35 USC 112, sixth paragraph. Moreover, no limitations from the specification are intended to be read into any claims, unless those limitations are expressly included in the claims.

**[0055]** Where a specific numerical value is mentioned herein, it should be considered that the value may be increased or decreased by 20%, while still staying within the teachings of the present application, unless some different range is specifically mentioned. Where a specified logical sense is used, the opposite logical sense is also intended to be encompassed.

What is claimed is:

**1.** A transmitter system for transmitting wireless electrical power, comprising:

a source which creates an output electrical signal having a specified frequency;

a coupling part, directly connected to said source, said coupling part formed of a first loop of wire which is impedance matched to said source; and

an antenna part, spaced from said coupling loop such that it is not directly connected to said coupling part, but magnetically coupled to a magnetic field created by said coupling part, said antenna part having no wired electrical connection thereto and receiving power wirelessly from said coupling loop, and said antenna part creating a magnetic field based on said power that is wirelessly received, said antenna part formed of a wire coil having an inductance L, and a capacitor having a capacitance C, and said antenna part having an LC value which is substantially resonant with said specified frequency.

**2.** A system as in claim **1**, wherein said antenna part has a quality factor greater than 500.

**3.** A system as in claim **1**, wherein said antenna part is formed on a substrate that supports said antenna part, and said substrate has a quality factor which is greater than 500.\*\*

**4.** A system as in claim **2**, wherein said antenna part is formed with an integral capacitor made from a vacuum capacitor.

**5.** A system as in claim **2**, wherein said antenna part has an inductive coil loop, and a capacitor connected across a portion of said inductive coil loop.

**6.** A system as in claim **5**, further comprising a cube shaped housing in which said capacitor is housed.

**7.** A system as in claim **5**, wherein said antenna part has a single turn in the coil loop.

**8.** A system as in claim **5**, wherein said antenna has two turns in the coil loop.

**9.** A system as in claim **1**, further comprising a receiver for the electrical power, where the receiver includes an antenna that is tuned to said specified frequency.

**10.** A system as in claim **9**, wherein the receiver has a quality factor value that is lower than a quality factor value of the transmitter.

**11.** A system as in claim **9**, wherein the receiver has a quality factor that is equal to or less than  $\frac{1}{4}$  of the quality factor of the transmitter.

**12.** A system as in claim **9**, wherein the receiver antenna has a size that is smaller than a size of the transmitter antenna.

**13.** A system as in claim **9**, wherein the transmitter antenna and receiver antenna coupled to one another in order to form an energy link that is operative like a loosely coupled transformer.

**14.** A system as in claim **1**, wherein said quality factor is a ratio of a resonant frequency of the antenna to a half power bandwidth of the antenna.

**15.** A system as in claim **1**, wherein said capacitor has a Q of at least 1000.

**16.** A system as in claim **1**, further comprising an attachment part across distal edges of material defining a loop, said attachment part holding a vacuum capacitor.

**17.** A receiver system for receiving wireless electrical power, comprising:

an antenna part, having no wired electrical connection thereto, configured for receiving a magnetic field, said antenna part formed of an inductive part with an inductance L and a capacitive part with a capacitance C, collectively defining an LC value which are substantially resonant with a specified frequency; and

a coupling loop, spaced from said antenna part, such that said coupling loop is not directly connected to said antenna part, but is magnetically connected to said antenna part, said coupling part receiving a signal having said specified frequency from said antenna part, and creating a power output based thereon.

**18.** A system as in claim **17**, further comprising an electrical circuit that receives said power output and creates output power based thereon.

**19.** A system as in claim **18**, wherein said antenna part has a quality factor greater than 500.

**20.** A system as in claim **18**, wherein said antenna part is formed on a substrate that supports said antenna part, and said substrate has a quality factor which is greater than 500.

**21.** A system as in claim **19**, wherein said antenna part is formed with an integral capacitor made from a vacuum capacitor.

**22.** A system as in claim **19**, wherein said antenna part has an inductive coil loop, and a capacitor connected across a portion of said inductive coil loop.

**23.** A system as in claim **22**, further comprising a cube shaped housing in which said capacitor is housed.

**24.** A system as in claim **22**, wherein said antenna part has a single turn in the coil loop.

**25.** A system as in claim **22**, wherein said antenna has two turns in the coil loop.

**26.** A system as in claim **19**, further comprising a transmitter for the electrical power, where the transmitter includes an antenna that is tuned to said specified frequency.

**27.** A system as in claim **26**, wherein the transmitter has a quality factor value that is lower than a quality factor value of the transmitter.

**28.** A system as in claim **26**, wherein the transmitter has a quality factor that is equal to or less than  $\frac{1}{4}$  of the quality factor of the transmitter.

**29.** A system as in claim **26**, wherein the transmitter antenna has a size that is smaller than a size of the transmitter antenna.

**30.** A system as in claim **26**, wherein the transmitter antenna and receiver antenna coupled to one another in order to form an energy link that is operative like a loosely coupled transformer.

**31.** A system as in claim **26**, wherein said quality factor is a ratio of a resonant frequency of the antenna to a half power bandwidth of the antenna.

**32.** A system as in claim **26**, wherein said capacitor has a Q of at least 1000.

**33.** A system as in claim **26**, wherein said capacitor is a vacuum capacitor.

**34.** A method, comprising:

creating a magnetic field at a specified frequency based on applied power using a first loop antenna which includes no separate capacitor attached thereto; and

coupling a portion of the wireless power between said first loop antenna and a second loop antenna that are associated with one another and are not electrically connected to one another, where said second loop antenna has a capacitor element that is separate from said loop, and where said second loop antenna has a resonant value at said first specified frequency.

**35.** A method as in claim **34**, wherein said first and second loop antennas are both transmit antennas.

**36.** A method as in claim **34**, wherein said coupling comprises coupling using a loosely-coupled transformer coupling.

**37.** A method, comprising:

receiving a magnetic field at a specified frequency based on applied power using a first loop antenna that has a capacitor element that is separate from said loop, and

where said second loop antenna has a resonant value at said specified frequency; and  
coupling a portion of the wirelessly-received magnetic field between said first loop antenna and a second loop antenna that are associated with one another and are not electrically connected to one another, and where said second loop antenna has no separate capacitor attached thereto; and

rectifying an output from said second loop antenna to create a DC output.

**38.** A method as in claim **37**, wherein said first and second loop antennas are both receive antennas.

**39.** A method as in claim **37**, wherein said coupling comprises coupling using a loosely-coupled transformer coupling.

\* \* \* \* \*