

SPRUSON & FERGUSON

COMMONWEALTH OF AUSTRALIA

PATENTS ACT 1952

DECLARATION IN SUPPORT OF A  
CONVENTION APPLICATION FOR A PATENT

In support of the Convention Application made for a patent for an invention entitled:

Device for the Cyclic Rearrangement of a Pile of Sheets

I/We, 1) Peter Ackeret and 2) Dr. Peter Helbling  
[full name of declarant(s)]

of 1) Allmendstr. 18, CH-8700 Küssnacht 2) Alte Landstraße 55, CH-8802 Kilchberg  
[full address of declarant(s) - not post office box]  
both in Switzerland

do solemnly and sincerely declare as follows:-

- 1. I am/We are authorised by LICINVEST AG, the applicant for the patent to make this declaration on its behalf.
- 2. The basic application as defined by Section 141 of the Act was made in the Federal Republic of Germany on 21 November 1987 by LICINVEST AG.
- 3. PETER ACKERET, of Allmendstrasse 18, CH - 8700 Küssnacht, Switzerland, is the actual inventor of the invention and the facts upon which the applicant is entitled to make the application is as follows:  
  
The said applicant is the assignee of the actual inventor.
- 4. The basic application referred to in paragraph 2 of this Declaration was the first application made in a Convention country in respect of the invention the subject of the application.

DECLARED at Zurich this 15th day of June 1989  
LICINVEST AG

Signature of Declarant

Peter Ackeret Dr. Peter Helbling

Managing Directors

TO: THE COMMISSIONER OF PATENTS  
AUSTRALIA

**(12) PATENT ABRIDGMENT (11) Document No. AU-B-27163/88**  
**(19) AUSTRALIAN PATENT OFFICE (10) Acceptance No. 614319**

- (54) Title  
**DEVICE FOR CYCLIC MODIFICATION OF THE DISTRIBUTION OF A PILE OF SHEETS**
- International Patent Classification(s)  
(51)<sup>4</sup> **G03B 023/02**
- (21) Application No. : **27163/88** (22) Application Date : **21.11.88**
- (87) PCT Publication Number : **WO89/04991**
- (30) Priority Data
- |                |                 |                                       |
|----------------|-----------------|---------------------------------------|
| (31) Number    | (32) Date       | (33) Country                          |
| <b>3739500</b> | <b>21.11.87</b> | <b>DE FEDERAL REPUBLIC OF GERMANY</b> |
- (43) Publication Date : **14.06.89**
- (44) Publication Date of Accepted Application : **29.08.91**
- (71) Applicant(s)  
**LICINVEST AG**
- (72) Inventor(s)  
**PETER ACKERET**
- (74) Attorney or Agent  
**SPRUSON & FERGUSON , GPO Box 3898, SYDNEY NSW 2001**
- (56) Prior Art Documents  
**AU 561888 57204/80 G03B 23/02 23/04**  
**AU 517556 39611/78 G03B 23/02**
- (57) Claim

1. A device for cyclic rearrangement of a pile of substantially rectangular sheets, comprising

a first frame part and a second frame part,  
a viewing window in one of said frame parts,

said second frame part being reciprocable relative to said first frame part between an inner end position and an outer end position over a stroke limited by stop means,

means for removing a sheet from a first end of a pile in the device when said second frame part is displaced from said inner end position to said outer end position and for adding said removed sheet to a second end of said pile when said second frame part is displaced from said outer end position back to said inner end position, said removing and adding means including transfer means for displacing said removed sheet from said first pile end toward said second pile end,

spring-biased pressing means for pressing said pile towards said viewing window when said second frame part is in said inner end position, said pressing means including two rail elements made of plastics material, said rail elements being arranged symmetrically with respect to a central plane of symmetry extending in the direction of reciprocation of said second frame part, each rail element having a length substantially equal to said stroke, each rail element being supported by

(11) AU-B-27163/88  
(10) 614319

-2-

a leaf spring, each leaf spring having a first end fastened to said first frame part and a second end supported by said first frame part, each leaf spring being bowed between said first and second ends towards said viewing window and connected approximately midway between said first and second ends to said rail element allocated thereto, and a space being provided between said rail elements for accomodation of said transfer means.

**PCT**

WELT: OPI DATE 14/06/89

APPLN. ID 27163 / 88

INTERNATIONALE ANMELD A0JP DATE 20/07/89  
INTERNATIONALE ZUSAMM

PCT NUMBER PCT/EP88/01053

**(51) Internationale Patentklassifikation<sup>4</sup> :****G03B 23/02****A1****(11) Internationale Veröffentlichungsnummer: WO 89/04991****(43) Internationales  
Veröffentlichungsdatum:**

1. Juni 1989 (01.06.89)

**(21) Internationales Aktenzeichen:** PCT/EP88/01053**(22) Internationales Anmeldedatum:**  
21. November 1988 (21.11.88)**(31) Prioritätsaktenzeichen:** P 37 39 500.9**(32) Prioritätsdatum:** 21. November 1987 (21.11.87)**(33) Prioritätsland:** DE**(71) Anmelder (für alle Bestimmungsstaaten ausser US):** LIC-  
INVEST AG [CH/CH]; Hartbertstraße 9, CH-7002  
Chur (CH).**(72) Erfinder; und  
(75) Erfinder/Anmelder (nur für US) :** ACKERET, Peter  
[CH/CH]; Allmendstraße 18, CH-8700 Küsnacht  
(CH).**(74) Anwälte:** SPARING, K. usw.; Rethelstraße 123, Post-  
fach 140 268, D-4000 Düsseldorf 1 (DE).**(81) Bestimmungsstaaten:** AT (europäisches Patent), AU,  
BE (europäisches Patent), BR, CH (europäisches Pa-  
tent), DE (europäisches Patent), DK, FR (europäi-  
sches Patent), GB, GB (europäisches Patent), IT (eu-  
ropäisches Patent), JP, KR, NL (europäisches Pa-  
tent), NO, SE (europäisches Patent), US.**Veröffentlicht***Mit internationalem Recherchenbericht.***(54) Title: DEVICE FOR CYCLIC MODIFICATION OF THE DISTRIBUTION OF A PILE OF SHEETS****(54) Bezeichnung: VORRICHTUNG ZUM ZYKLISCHEN UMSCHICHTEN EINES BLATTSTAPELS****(57) Abstract**

A device for cyclic modification of the distribution of a pile of sheets comprises a housing with a window, a drawer which can be slid in and out of the housing, and means for withdrawing a sheet from a pile placed in the housing and transferring it to the other side of the pile during each cyclic movement of the drawer. When the drawer is fully inserted in the housing, the pile is pressed against the window by a compression device which comprises rails supported on leaf springs. Functional elements such as anchorage extensions, sheet limit stops, locking catches, spacing ribs and forward feed teeth are molded on the rails.

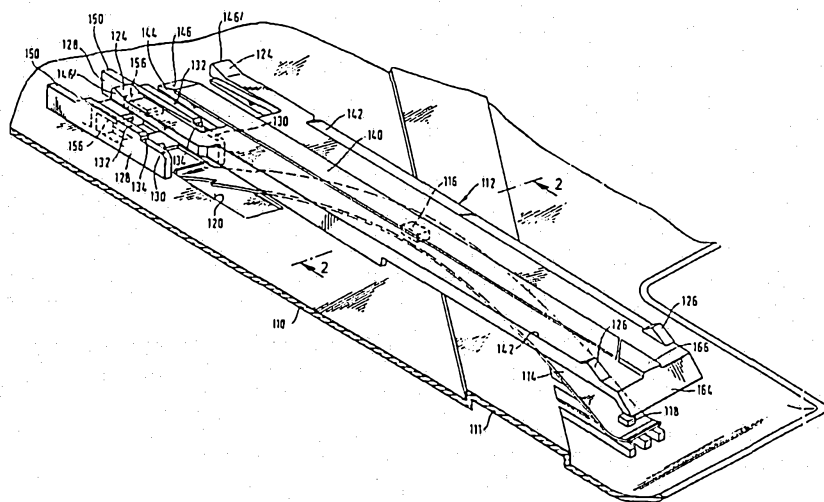
**(57) Zusammenfassung**

Vorrichtung zum zyklischen Umschichten eines Blattstapels mit einem ein Sichtfenster aufweisenden Gehäuse, aus dem ein Schieber herausziehbar und wieder einschiebbar ist, und mit Mitteln zum Abziehen eines Blatts von einem eingelegten Stapel und zum Transfer desselben auf die andere Stapelseite bei jedem Bewegungszyklus des Schiebers. Bei eingeschobenem Schieber wird der Stapel von einer Anpreßeinrichtung gegen das Sichtfenster gedrückt, die auf Blattfedern abgestützte Schienen umfaßt. Die Schienen weisen angeformte Funktionselemente auf, wie Verankerungsfortsätze, Blattanschläge, Sperrnasen, Distanzierungsrippen und Vorlaufzinken.

Abstract

A device for the cyclic rearrangement of a pile of sheets with a housing having a viewing window, from which housing a slider member can be withdrawn and reinserted, and with means for removing a sheet from an inserted pile and transferring the same to the other end of the pile on each movement cycle of the slider member. When the slider member is inserted the pile is pressed against the viewing window by a pressing arrangement which comprises rails supported on leaf springs. The rails have integrally moulded function elements, such as anchoring projections, sheet stop members, blocking projections, spacer ribs and guide prongs.

Fig. 1

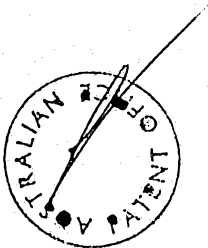

Device for the cyclic rearrangement of a pile of sheets.

The invention relates to a device for the cyclic rearrangement of a pile of substantially rectangular sheets of nominally identical thickness.

Such a device, which here and hereinafter shall be referred to as a "sheet-changer" for short, is described and illustrated in publications WO 86/03019, WO 86/03018, WO 86/03022, WP 86/03026, WO 86/03028, WO 86/03029, WO 86/03030.

The known device comprises a housing provided with a viewing window and forming the first frame part, and a slider member forming the second frame part. The separating elements are formed on the one hand by a step which is arranged fixedly in the housing, and on the other hand by an inner transverse member of the slider member called the separator. The feeding means comprises free ends of hook-like construction of springs mounted in the housing, which engage the edges of the sheet lying furthest away from the step. The individual sheet is held in the housing in that in the housing there are fixedly arranged retentive coatings extending in the direction of movement of the slider member, against which retentive coatings the individual sheet is pressed by small rollers mounted on the separator. The separator also serves as a retaining means for holding the remainder of the pile in the slider member. The guide means comprises the free ends of spring arms mounted in the housing that lift the individual sheet away from the retentive coatings when the slider member is pulled and guide it in front of a return slot defined by the separator. The pressing device too is formed by the free ends of spring arms



mounted in the housing, namely by a pair of springs of the feeding means and a pair of spring arms forming the guide means. The spring arms are respectively controlled, released and depressed by these springs for given portions of the relative movement of the slider member.

With the slider member inserted, the pile rests on ledges of the slider member parallel with the viewing window, the ledges defining a level which is closer to the viewing window than that of the retentive coatings so that the pile is spaced from the retentive coatings on reinsertion of the slider member. Furthermore, the separator is designed such that, as the slider member is withdrawn, it is not possible for one or more sheets to be separated from the remainder of the pile in addition to the separated individual sheet. Reference should be made to the content of the said publications for further details.

The known picture changer gives no cause for complaint as regards its function. However, it is in need of improvement in two areas:

Firstly, a large number of functional elements are provided, which have to be manufactured separately and the correct co-operation of which cannot be determined until they are assembled. Secondly, the control of the spring functions by the slider member causes variable friction conditions over the withdrawal path, which the user is able to feel clearly.

It is the aim of the invention to develop the sheet changer of the preamble such that its manufacture is simplified and at the same time the relative movement of the frame parts can take place with essentially the same or at least very gradually variable and minimal friction over the withdrawal path.

~~This problem is solved by the characterizing~~



Accordingly, the present invention provides a device for cyclic rearrangement of a pile of substantially rectangular sheets, comprising a first frame part and a second frame part, a viewing window in one of said frame parts,

5 said second frame part being reciprocable relative to said first frame part between an inner end position and an outer end position over a stroke limited by stop means,

means for removing a sheet from a first end of a pile in the device when said second frame part is displaced from said inner end position to 10 said outer end position and for adding said removed sheet to a second end of said pile when said second frame part is displaced from said outer end position back to said inner end position, said removing and adding means including transfer means for displacing said removed sheet from said first pile end toward said second pile end,

15 spring-biased pressing means for pressing said pile towards said viewing window when said second frame part is in said inner end position, said pressing means including two rail elements made of plastics material, said rail elements being arranged symmetrically with respect to a central plane of symmetry extending in the direction of reciprocation 20 of said second frame part, each rail element having a length substantially equal to said stroke, each rail element being supported by a leaf spring, each leaf spring having a first end fastened to said first frame part and a second end supported by said first frame part, each leaf spring being bowed between said first and second ends towards said 25 viewing window and connected approximately midway between said first and second ends to said rail element allocated thereto, and a space being provided between said rail elements for accommodation of said transfer means.

Further features and advantages of the invention will become 30 apparent from the subsidiary claims and from the description of exemplary embodiments.

Exemplary embodiments of the invention are explained in detail below with reference to the accompanying drawings.

Fig. 1 shows in perspective view a sprung rail and components of 35 the housing co-operating with it,

Fig. 2 shows diagrammatically a cross-section in the region of the rail in co-operation with the separator shoe,



JLH/STA/332E

- Fig. 3 is a longitudinal section through the separator shoe,
- Fig. 3a shows the shoe in perspective,
- Fig. 4 is a section at right angles to the direction of movement of the slider member across the width of the slider member,
- Fig. 5 shows the conditions during insertion of the slider member, analogously to Fig. 2,
- Fig. 6 shows the positions of the parts level with the separator shoe on insertion, analogously to Fig. 5,
- Fig. 7 shows in a diagrammatic side view the position of the shoe and the rail with only a few sheets in the changer,
- Fig. 8 is a diagrammatic longitudinal section of the relative position of the parts when the slider member is inserted,
- Fig. 9 shows the start of the withdrawal,
- Fig. 10 shows a somewhat later phase,
- Fig. 11 shows in detail, in a diagrammatic longitudinal section, the initial phase of the rearranging process with the separator and rails co-operating,
- Fig. 12 shows a next phase in analogous view,
- Fig. 13 shows a later phase,
- Fig. 14 shows a subsequent phase,
- Fig. 15 shows the next phase,
- Fig. 16 shows, analogously to the preceding Figures, the relative position of the parts when the slider member is pulled out,
- Fig. 17 shows in detail the end position of the separator relative to the rails,
- Figs 18 to 20 correspond to Figures 8 and 16 and 15 respectively, in an alternative



- configuration of the rails,
- Fig. 21 shows the front end of a rail from Figs 18 to 20,
- Fig. 22 is a longitudinal section through the closed changer to illustrate the housing construction,
- Fig. 23 is a partial section at right angles to the section plane of Fig. 22 on an enlarged scale compared to the latter,
- Figs 24 to 29 show the behaviour of the auxiliary springs in different phases and modes of operation of the changer,
- Figs 30 and 31 show in two different phases the mode of operation of an alternative form of the retaining means for the individual sheet,
- Figs 32 to 34 show diagrammatically a further construction for retaining an individual sheet,
- Figs 35 to 37 show in partial section under two planes at right angles to one another the releasing device for removal of the entire pile,
- Figs 38 and 39 show in diagrammatic longitudinal section the mode of operation of this element,
- Fig. 40 shows a perspective view of a changer, and the operation of the changer in general will now be explained with reference to this Figure.
- Figs 41a, b illustrate a problem that occurs with bowed sheets,
- Figs 41c and 42 show a form of rail for eliminating this problem,
- Figs 43 to 46 show four phases of the commencing changeover process at the other end of



the rails of the modified form of embodiment,

- Fig. 47 shows in a perspective partial view the modified rail anchoring system,
- Fig. 48 shows in a diagrammatic vertical sectional view the position of the co-operating parts with the frame parts pushed together,
- Fig. 49 shows in an analogous view the situation with the frame parts pulled partly apart,
- Fig. 50 shows in partial perspective view the elements for disabling the change-over process,
- Fig. 50a shows the co-operation of rails, separator and slider member in partial perspective view,
- Fig. 51 shows in perspective view the bent wire part which is inserted into the rails shown in Fig. 50,
- Fig. 52 illustrates the assembly of the bent wire parts,
- Fig. 53 shows on a very enlarged scale the mode of operation of the disabling member,
- Fig. 54 shows in cross-section through the rails the position and mounting of the wire member,
- Figs 55 to 58 show four phases of the disabling of the system,
- Fig. 59 shows, in a plan view onto the bottom side of the housing, the arrangement of the disabling system,
- Fig. 60 is a section on a level with the line 60-60 from Fig. 59,
- Figs 61A to 61C show details of the disabling system in operation,
- Fig. 62 shows an enlarged view of another



modified embodiment in partial vertical section,

Figs 63 and 64 show the procedure at the start of withdrawal of the slider member,

Fig. 65 shows analogously to Fig. 62 a further form of embodiment, and

Fig. 66 shows yet a further alternative in an analogous illustration.

The changer shown in Fig. 40 is similar to a conventional picture frame for hanging up or standing up. It comprises a housing 100 which on its top side (where the terms "top" and "bottom" are used in the following description, they refer always to the position in relation to the housing, regardless of how this itself is arranged in the room) has a viewing window 102 in the form of a transparent pane 102. Parallel with the plane thereof, a slider member 104 can be withdrawn from and inserted into the housing, and on each complete backward and forward movement of the slider member a sheet change is effected in normal operation, that is to say, a pile of sheets, for example photographs, accommodated in the changer is cyclically rearranged in such a manner that, as the slider member is withdrawn, the lowermost sheet of the pile is held firmly in the housing, whilst the slider member carries the remainder of the pile with it out of the housing; as the slider member is reinserted, the picture is deposited on top of the remainder of the pile. Inside the housing there is an arrangement for exerting pressure on the pile which presses the pile upwards when the slider member is inserted and which is pressed downwards as the slider member is withdrawn. This is effected by means of a rear and inner transverse member of the slider member, which, because it separates the individual sheet from the remainder of the pile, is called a "separator";



the slider member comprises furthermore two parallel lateral bars 106 of L-shaped cross-section, and a front assembly 108; since the slider member is open underneath, the pressing arrangement secured in the housing is able to act on the sheets carried by the lateral bars of the slider member.

Fig. 1 shows the base plate 110 of the changer housing, the countersunk groove 111 serving to accommodate a stand, such that it can be let in flush and folded out, for positioning the changer in the manner of a stand-up frame. A pile of sheets (not shown) is pressed by a pressing arrangement towards the viewing window 102 provided in the housing for as long as the slider member 104 is inserted fully into the housing.

The pressing arrangement comprises two rails 112 parallel with one another and with the direction of movement of the slider member 104, each of the rails being fastened to an associated leaf spring 114. For this purpose the rail, which is injection-moulded from plastics material, has a rivet projection 116 which, on assembly, is pushed through a corresponding opening in the metal leaf spring and is expanded by deformation behind this. One end of the leaf spring 114 is placed on a locating peg 118 on the base 110 of the changer housing, while the other, free end of the leaf spring, although it is supported laterally by the walls of a groove 120 in the housing base, is able to move in the longitudinal direction of the rail (here and elsewhere, "longitudinally" means "in the direction of the slider member movement"; "transversely" means at right angles to the longitudinal direction). The leaf spring is formed into an upwardly arched bow, and the rail 112 is fastened approximately in the middle thereof. As the two rails and the associated springs and housing parts are of mirror-symmetrical construction relative to the



centre line plane of the changer, only one half of the pressing arrangement needs to be explained in detail.

On withdrawal of the slider member 104, the separator 122 thereof runs onto the two outer prongs 124 at the inner end of the rail 112 ("inner" means "furthest away from the slider member front", "outer" means "close to the housing opening through which the slider member moves"), and presses it downwards against the force of the leaf spring 114. As this happens, the pile of sheets (Fig. 10) supported by the rails 124 also moves away from the viewing window 102 and the separator carries the pile outwards, with the exception of the lowermost sheet which is held firmly on the rails. The following steps are taken for this purpose:

Close to its outer end, the rail has integrally moulded upstanding projections 126 from which the lowermost sheets of the pile derive support, so that they are checked in relation to the separator movement. Close to the inner end of the rail, moulded integrally with the housing base 110 on either side of the prongs 124 there are upright, narrow rails 128, which have a support face 130 parallel with the housing base and parallel therewith a blocking face 132, the two faces being separated from one another by a step 134. As soon as the rails 112 have been pressed down by the separator, the inner edge of the lowermost sheet of the pile positions itself on the support faces 130. The step 134 has a height which is greater than the thickness of a single sheet but less than the thickness of two sheets, so that this edge of the lowermost sheet lies protected behind the step and the separator passes over it. The next lowest sheet on the other hand is carried by the separator and slides off the projections 126. On the side of the separator facing the rails there are mounted spring-loaded shoes 136 with small rollers 138, as will be explained hereinafter in detail.



The small rollers have a width which is approximately the same as that of a retentive covering strip 140 arranged centrally on each rail.

The retentive covering is so called because it consists of a material which has a distinctly greater friction coefficient with the material of the sheets to be changed than this latter material has with itself (that is to say, the friction between the lowermost sheet and the retentive covering is much greater than the friction between the lowermost sheet and sheet immediately adjacent to it in the pile). The retentive covering may consist merely of a roughened area on the rail material, or alternatively of a special coating of an elastomer or a similar material. The force of the spring 114 acting from below presses the lowermost sheet with the retentive covering towards the associated small roller, so that the sheet is held firmly gripped.

The rail cross-section shown in Fig. 2 reveals the action of two lateral upright ribs 142: the top side of the retentive covering lies recessed with respect to the plane which is defined by the ribs and in which the individual sheet lies, and the small roller distorts the sheet, as shown (exaggeratedly) in Fig. 2. This is important for the return travel of the slider member, during which the individual sheet is located at the top close to the viewing window and the remainder of the pile is being transported inwards along the rails into the housing again: the small rollers of the separator then run in front onto the retentive coverings (Fig. 6), while the sheet that is then lowermost in the remainder of the pile is held by means of the ribs 142 away from the retentive coverings 140, so that these ensure the unchecked insertion of the remainder of the pile (Fig. 5).

Fig. 6 shows that the small roller 138 is narrower than the shoe 136 which in its turn, when the



slider member is fully inserted, is wide enough to position itself, between the prongs 124 and on both sides of the central tongue 144 of the rail on which the retentive covering ends, on the blocking faces 132, and to lie on these under spring force when the slider member is pulled. The shoe on the one hand and the support faces on the other hand thus define a through-slot for the individual sheet, and the slot height is determined by the step 134. Only when the relevant edge of the individual sheet projects into the through-slot does the small roller run gently onto the inclined run-on edge 146 at the free end of the tongue 144; more accurately, this tongue positions itself gently from below against the small roller because the rail end, as a result of the separator 122 on both sides of the shoe meeting the thickened ends 146' of the prongs 124, had pressed the rail down "too far".

As Figs 3 and 3a show, the shoe 136, together with the small roller, which preferably consists of metal, forms an assembly which is movably guided in the separator. Between a transverse member 137 of the shoe and a support 139 integrally moulded with the separator there is inserted a helical compression spring 131. On each side of the spring the separator has projections 133 with a right-angled bend which engage beneath a top face 129 of the shoe and by means of a snapped-in lug prevent the shoe from falling out; the shoe, however, can be displaced against the spring bias for a limited distance in a direction approximately parallel to the inclined run-on face 148 of the separator. The small roller 138 is installed from below into the bearing blocks 143 of the shoe and is safeguarded against falling out in a manner not illustrated. These safeguarding means are not necessary for operation, but simplify assembly. The edge 145 of the shoe running in front of the small roller as the slider member is



withdrawn is set back with respect to the small roller to such an extent that it is not able to touch the individual sheet even when there are only a few sheets in the changer and the rails are therefore inclined steeply towards the plane of the viewing window (Fig. 7).

Figs 8 to 10 show in a diagrammatic side view the steps in the initial phase of the sheet change-over, while Figs 11 to 15 show parts of this in detail.

Stationary phase: Fig. 8. The shoes 136 are not yet resting on the blocking faces 132, but are supported by means of stops on the separator, since the blocking faces 132 at their end remote from the steps 134 likewise have a step 150. This is angled so that the shoe is able to slide on, in the same way as the step 134 and the support face 130 have run-on slopes which co-operate with a corresponding slope 152 of the shoe. The dimensions are such that when the slider member is fully inserted the shoe comes to rest exactly behind the slope of the step 150, so that the changer is not able to open on its own but requires a certain, even if only slight, pulling force to be exerted on the slider member.

The top edge 154 of the separator lies immediately in front of the thickened portions of the springs 124, but the rails are still able to move freely under the action of the springs 114 towards the window or press an inserted pile against this.

Preparatory phase: Figs 9 and 11. The slider member is withdrawn by a few millimetres. The inclined face 148 of the separator 122 has run onto the prongs 124 and has pushed these downwards a little way. The leaf spring 114 is extended somewhat by this and since it is fixed at its outer end to the housing base, its inner end travels counter to the withdrawal direction of the slider member, and the rails too are displaced



relative to their starting position.

Separating phase: Fig. 12. The edge of the shoe 136 running in front of the small roller passes over the end transverse edge of the lowermost sheet of the pile facing towards it.

Start of the retaining phase: Fig. 13. The shoes have passed over the support face, and the small rollers 138 have positioned themselves on the inclined face 146; the separator pushes away the remainder of the pile in front of it. As clearly shown in Fig. 10, the leaf springs 114 have been even further extended, and the rails have been displaced still further in an inward direction.

Retaining phase: Figs 14 and 15. The separator approaches even closer to the connection point between rail and leaf spring. The leaf spring is almost fully extended and the inclined face 146 of the inner middle tongue of the rail projects beneath hooks 156 which are integrally moulded internally on the rails 128. Without these hooks the inner end of the rails 112 would rise again under the action of the leaf springs 114 as soon as the separator has been moved out beyond a pivot point close to the rail centre; but the rails remain depressed until the slider member has reached its outer end position and also during the inward path of the slider member until the other side of the pivot point of its stroke.

The situation shortly before the outer end position of the slider member is illustrated in Figures 16 and 17. The Figures show that the small rollers 138 have already passed over the outer transverse edge of the individual sheet 160 so that this is no longer held gripped but lies beneath the inner end of the shoe 136. Close to their outer end, the rails 112 have a downwardly angled projection 164 which reaches close to the housing base 110, but does not touch this (as



otherwise the rail would jam between the separator and the base). This projection prevents the leading edge of a sheet from getting beneath the rails as the device is filled with sheets.

Shortly before the outer end of the rails 112, their retentive covering 140 also terminates. The end of the retentive covering is cut off at an angle and in front of this the rail has a raised portion 166 terminating in a corresponding angle, the height of the raised portion not being constant, however, but decreasing from one longitudinal side to the other. In this manner it is possible to ensure that the small roller rolls on and off the retentive covering without being checked by this, although it has noticeable thickness tolerances.

Figures 18 to 21 show an alternative configuration of the rails. Instead of the integrally and rigidly moulded-on projections 164, in this case a movable projection 170 is connected by way of a so-called film hinge 172 to the rail body and is guided by means of a straight guideway 174 on the housing base. Fig. 20 shows the situation in which the slider member is but incompletely withdrawn, so that the resilient rails still project with their outer ends; if an attempt is now made to insert sheets, the projection reliably prevents sheets being able to get beneath the the rails. In this case, the rail would be made from a suitable plastics material, with the film hinge being capable of withstanding continuous alternating stress, for example polypropylene.

Figs 22 and 23 reveal clearly the construction and arrangement of the auxiliary springs 162 and 163. These are relatively weak leaf springs which are fastened at one end to the housing base, namely beneath the slider member lateral bars 106 so that when the slider member is inserted they are depressed. If the



slider member is pulled (Figs 24 to 27), the inner auxiliary spring 162 first of all lifts the inner end edge of the individual sheet in front of a stop 175, and when the slider member is fully pulled out the leading edge of the individual sheet is also lifted, so that it lies in front of the top side of the separator 122 and is able to pass through the gap between this and the top side of the housing when the slider member is pushed back.

As long as the changer is filled with sheets, as the slider member travel commences the separator runs onto the lowermost sheet and this presses the auxiliary springs lying laterally next to the rails with it beneath the separator. If the changer has not been filled, the auxiliary springs project freely upwards. So that in this case they can nevertheless be pressed down by the separator, this has corresponding recesses 177 with a wedge-like angled part which is sufficient to allow the free spring ends to slide down, as indicated in Figs 28 and 29.

Figs 30 and 31 show an alternative method of holding the individual sheet on the rails 112. On the underside of the rails there is integrally formed a slideway 180 in which a sheet metal gripper 182 is inserted such that it can be displaced to a limited extent in the direction of the slider member movement. In the starting phase (Fig. 30), the separator 122 runs first of all onto an upwardly directed spring hook 184 of the gripper and carries this for a limited distance with it, until the angled stop portion 186 meets the rear end of the rail. As this happens, the gripper is pushed with its spring hook end over the inner transverse edge of the sheet and holds this firmly. The spring hook yields resiliently outwards on further travel of the slider member. Close to the outer end position of the slider member, the separator passes over



an outer spring hook of the gripper. As the slider member is pushed back, the separator presses the gripper into its starting position again in that it runs onto this outer spring hook 188 until the gripper strikes the front rail end. The sheet is now released and can be lifted by the auxiliary springs 162. On further insertion of the slider member the spring hook 188 yields inwards (shown by a broken line) and the same applies to the inner spring hook 184.

Figs 32 to 34 illustrate another alternative for retaining the individual sheet. Close to the outer end of the rail 112, a pivotable angled member 190 is mounted thereon such that it pivots about a pivot point 192. Starting from the stationary position (Fig. 32), first of all the individual sheet 160 is checked at the projections 126, while the remainder of the pile runs over the inwardly directed arm of the pivotable angled member, which arm tapers to an edge like a knife blade and, after the slider member has travelled a short distance, meets the upright second arm of the pivotable angled member. The pivotable angled member is deflected thereby but the blade-like arm is unable to lift the remainder of the pile, so that it is resiliently deformed. The individual sheet is now also pushed over the projections 126 (Fig. 34) until its outer transverse edge meets the stop projection 194 of the pivotable angled member. The tapered extension arm is thereby held pressed over the transverse edge for as long as the remainder of the pile is being moved. When the separator also has passed over the projection 194, the pivotable angled arm is able to spring up and release the individual sheet. During the return travel, the pivotable angled member is displaced back into its starting position again.

Figs 35 to 39 illustrate the means serving to disengage the change-over function, so that when the



slider member is pulled the entire pile is transported by the slider member out of the housing. These means comprise a frame 200, the longitudinal struts 202 of which are displaced from below into recesses 204 on the underside of the separator 122 and in so doing lift the sheet edges lying in front of the separator to such an extent (Fig. 38) that the lowermost sheet is unable to get into the through-slot beneath the shoe 136; this sheet also is therefore carried along by the slider member (Fig. 39). The frame rests on a button 206, which in turn is fixed by way of a plastics spring 208 on the housing base 110 and can be displaced manually through an aperture 210 in the housing base.

The rest position of the button, in which the change-over function is "switched on", is illustrated in Fig. 35. If the button is pressed, then under the compression of the spring 208 it snaps over the locking edge 212 of the housing aperture 210 into the position shown in Fig. 37, in which the frame 200 blocks the change-over. If, as the slider member is withdrawn, the separator now runs onto the transverse strut 214 of the of the frame 200, this and with it the button 206, is tilted, so that the button is able to snap back into its initial position again, the tilting motion being effected about a stop 216. The spring 208 is secured to a base 218, which protrudes from the housing base 110, and is guided against a rib 220 so that the frame assumes the position parallel to the housing base shown in Fig. 37 even when the button is depressed.



Figs 41a, b, c and 42 show the end of a rail of an alternative embodiment. It is desirable to retain the individual sheet in the housing with a maximal force and the best engagement is provided by a "hook" lying adjacent the sheet edge, which hook extends approximately at right angles to the sheet plane. The hook, however, must not exceed a height equal to the thickness of one sheet, in the case of photographic prints for example about 0.25 mm, so that the second lowermost sheet and all the following ones are able to pass over it. As long as all sheets are perfectly plane, such a system would function. But this is not always the case, however, because, for example, photographic prints bow depending on the atmospheric humidity, for example about a transverse axis; in this case such a short hook is unable to grip the lowermost sheet (Fig. 41a). The pressure exerted by the springs 306 on the rail is not sufficient to flatten the sheets lying thereupon and thus bring the hook into engagement with the lowermost sheet. For this reason a rail profile according to Fig. 41b is preferred. Fig. 41c shows the rail end on an enlarged scale, and Fig. 42 illustrates a functional detail. The twin hook 300 extends upwards at right angles from a short plateau 301. It forms the end of a sloping ramp 302 which starts from the plane upper side 303 of the rail. The supported concavely bowed sheet follows the ramp and is engaged by the hook. If by chance the sheet to be separated is somewhat shorter than the sheet immediately following it, it is carried by the separator shoe in the direction towards the hook and throws off the sheet lying above it even when this is convex (Fig. 42); as it does so its leading edge slides along the plateau 301. This plateau also prevents the leading edge of the second lowermost sheet from being temporarily engaged



and damaged by the hook if the rail assumes an extremely oblique position owing to the fact that there are only a few sheets in the changer.

The retentive coating 140 also has a sloping ramp 305 parallel to the ramp 302 so that the sheet to be separated is not too badly deformed by the small roller between the two ramps 302.

Figs 43 to 46 show the other end of one of the rails shown in Fig. 41, 42 co-operating with the separator 400, the shoe 402 thereof, the small roller 404 and the support 406 and the blocking face 408. As in the first embodiment, the rail has a three-pronged end, but the contour of the prongs is of somewhat different design.

Fig. 43 shows how, after the start of the slider member withdrawal, the inclined face 410 of the separator has run onto the thickened prongs 412 of the rail. Between Figs 43 and 46 the inclined position of the rail varies between, for example,  $5^{\circ}$  and, for example,  $7^{\circ}$ . Fig. 44 shows how the separator follows with a rounded-off portion 414 the upper curvature of the prongs 412. After the portion 414 has passed over the prongs, the upper curvature of the prongs 412 lies against the plane face 416 of the separator, which face now rides on the outer prongs of the rail. In so doing, the shoe 402 approaches with its small roller 404 the middle prong 418 of the rail, so that the small roller is able to run on the rounded control face 420 thereof. On further travel of the slider member, the rail is finally pressed down into its lowermost position, shown in Fig. 46.

In Fig. 46, two sheets 422, 424 are illustrated. The sheet 422 is intended to remain in the housing, while the sheet 424 is to be transported by the separator, or the shoe 402 thereof. It will be seen that the shoe has a transporter edge 426 which extends



at a steeper angle than the inclined face 410. The sheet 422 is positioned on the support 406 and cannot be engaged by the transporter edge since it is held by the sheet 424 behind the step that separates the support face 406 from the blocking face 408. It is essential that the rail "dips" sufficiently far so that the sheet edges are not prevented from being positioned on the support 406.

The perspective illustration of Fig. 47 clearly illustrates the shape of the prongs. On both sides of the control face 420 there is a free space 428 for safety reasons. Although the small roller 404 has an axial dimension that is the same as the width of the central prong 418, the slider member necessarily has some free play in the housing, so that\* without those free spaces the shoe 402 could strike with its edge 426 against the control face before the small roller presses the rail away; this can be seen clearly in Fig. 45.

It was explained above that this end of the rail is anchored, such that it performs a rocking movement, beneath immovably integrally moulded hooks when the slider member has passed over the pivot point of the leaf spring/rail system. Such a construction, however, is very demanding as regards the accuracy of manufacture and assembly because, when the sheet changer is completely filled, the remaining rail travel between the freely movable rail, when the slider member is inserted, and the anchoring position, when the slider member is withdrawn, is only extremely small, for example a few tenths of a millimetre.

It is therefore preferred to design the hook so that it is not immovable but movable, so that, controlled by the slider member movement, it is able to

\*"So that" is not meaningful in English here; "since" would make better sense than "so that" - translator.



assume a holding position on top of the rail, or a release position. It is desirable for the hook not to reach its engaging position until after the rail has been depressed so that the latter will engage the hook from beneath.

This is achieved by the construction illustrated in Figs 47, 48 and 49. It should be noted that in Fig. 47 the rail and the engagement system are drawn in an exploded view; the actual position of the parts is shown in Figs 48 and 49, respectively.

Between the ribs 430 having the support and the blocking faces, there is arranged a spring-biased anchoring bracket 432. This is a punched and bent component of resilient sheet metal having a first window 434, the transverse member 436 of which pivots over the extension 438 of the rail as soon as the free control projection 440 has been released by the separator (or more accurately by the small roller thereof).

The control extension has a second window 442, so that when the slider member is inserted the extension does not rest on the central rib 444 which is integrally formed with the housing base 446. The central rib has two functions. Firstly, the anchoring bracket 432 is anchored by snap-fitting to the end edge 448; the retaining bracket is guided beneath a pin 450 which extends transversely to the direction of movement of the slider member. The second function of the central rib 444 consists in forming a guide ramp 452 for the small roller 404. When the slider member is inserted, both the small roller and the shoe should be subjected to only slight spring bias. During the change-over operation, however, the shoe, which is engaged by the separator via a spring, is pressed with fairly strong bias against the blocking face 408. For this reason the blocking face 408 is recessed at 454, so that the shoe does not engage it. At the start of the slider



member movement, the small roller runs first of all onto the ramp 452 and lifts the shoe higher than the level of the blocking face 408, onto which the shoe is then lowered as soon as the small roller comes clear of the middle rib.

The user should be able to disable the change-over function so that the entire pile can be transported out of the housing by the slider member. accordingly, means are required which

- lift the end of the lowermost sheet of the pile away from the support so that it can be engaged by the shoe, and
- release the other end edge of the same sheet from the hooks 300.

These means are illustrated in Figs 48 to 61.

The housing base 446 has an aperture 460 with integrally moulded guiding rails 462, between which a key 464 is snap-fitted. The key is displaceable by a limited distance in the direction of the slider member movement, thereby carrying with it an integrally moulded transverse member 466 which in its turn displaces a pair of wedge-shaped ribs 468. These extend next to the inner ribs 430 and parallel therewith and, as shown in Fig. 55, each wedge-shaped rib 468 has a horizontal upper edge 470 on the same level as the blocking face 408. On displacement of the key 464 in the direction of the housing opening, the edge 470 assumes the position shown in Fig. 55, and it will be seen that the lowermost sheet cannot be positioned on the support 406 but has to be taken away by the shoe. The wedge-shaped ribs furthermore have a control edge 472 which here extends at an angle of, for example, 45°. Its function will be explained later.

Fig. 50a shows the co-operation of the separator, the shoes connected to it, the small roller located in these, and the rails. In particular, to the foot part



411 of the slider member side rail there is fastened a lifting spring 413 which lifts the separated individual sheet in front of a return slot during the return stroke of the separator.

The displacement of the other sheet end from its position in front of the hooks 300 necessitates a modification of the rails, the position of the rails not being predictable when the slider member is inserted because this position depends upon the number of sheets that are contained in the device. Provision is therefore made for such a modification of the rails to be effected when the rail, after the start of the slider member withdrawal, follows a path which is forced upon it by the separator regardless of the number of sheets.

Each rail carries a control member 474 which is bent from a single piece of wire. The two free ends of the wire member are provided with eyelets 476 that co-operate with a control ramp 478 of the rail. A displacement of the eyelets to the left in Fig. 53 results in a sheet, which would otherwise assume a position in front of the hooks 300, being guided over the latter, so that the hooks remain ineffective. At the same time, the spring is biased (or an existing bias is increased) so that the eyelets 476 tend to return to their withdrawn position, illustrated in Fig. 53 by a solid line, and which is defined by the stop 480.

The other end 482 of the control member is guided and bent at right angles beneath the middle prong 418 of the rail. When the separator depresses the inner rail end, this transversely extending wire portion strikes against the control edge 472 of the wedge-shaped rib. The control member is therefore shifted ever further to the left with continuing depression of the rail end, with the eyelets being displaced correspondingly. Fig 58 shows that this displacement has already been



concluded before the transporter edge of the shoe meets the transverse edge of the lowermost sheet of the pile. A transverse rib 484 moulded integrally with the rail body spaces the leaf spring 486, by which the rail is carried, from the control member end 482, so that the latter cannot be clamped by the spring 486 and remains freely movable, even when the rail has been fully depressed.

The control member is mounted on the rail by a snap-fit method. The rail has two parallel grooves 488 in which the longitudinal portions of the member are freely displaceable. At one point over each of these grooves there extends a claw 490 around which the free ends of the control member are bent and behind which they assume their extended linear shape again. A widened portion 492 of the groove enables the wire to be deformed simply by pressing on it and to be mounted by means of a snap-fit there and then.

There are additionally provided means that prevent incorrect operation, that is to say, an actuation of the key 464 with the slider member partly withdrawn, and that ensure that the key and all components connected therewith are returned automatically to their initial position. These means are illustrated in Figs 60 to 61C, Fig. 60 being a cross-section level with the key 464 and Figs 61B and C being partial sections taken at right angles thereto.

The transverse member 466 comprises an upper bar 467, which is able to yield in the direction of the key 464, and a guiding bar 469 lying therebeneath which is connected to the key and, by way of the wedge-shaped ribs 468, to the upper bar. From the latter there extend inwards, that is, in the opposite direction to that of the wedge-shaped ribs, a central arm 471 with a hole 473, and also downwards two control pins 475. A reset tongue 477 with which is associated a reset



projection 497 integrally moulded with the housing base extends backwards from the key 464.

Fig. 61A shows the initial position with the slider member pushed in. It will be seen that the separator has on its underside a recess 479 terminating in a control ramp 481; a cam projection 483 integrally moulded with the upper bar 467 projects into this recess. If, starting from this position, the key is displaced to the left in Fig. 61B to disable the change-over function, the cam projection 483 is pressed downwards by the control ramp 481, taking the central portion of the upper bar 467 downwards with it. The hole 473 of the locking arm 471 comes free of a locking pin 485 moulded rigidly on the housing, and the control pins 475 too are able to yield resiliently downwards into corresponding recesses in the housing base. The reset tongue yields resiliently as it passes over the reset projection. Even if the slider member is only partly withdrawn, the key remains latched. The separator is able to run over the actuated key to deform the upper bar again, since even in this position of the key there are recesses in the housing base lying opposite the control pins. (Fig. 61C). As the slider member is returned, it displaces the key initially for a short distance to where the control pins are locked so that the bar 467 is unable to yield resiliently; instead, the entire assembly of the key is returned to the initial position as a result of the reset tongue being deflected by the rest projection.

Figs 62 to 64 show a modified form of embodiment of the pile transporting elements particularly suitable for co-operation with the hook-like transporter 300 for the individual sheet. As these transporters engage virtually at right angles to the sheet plane, the separating force is maximal. However, this is only effective if the second sheet to be separated from the



individual sheet is engaged and displaced with at least approximately the same maximal force. That is to say, the end face of the shoe engaging the second lowermost sheet should extend also at right angles to the sheet plane.

In the constructions described so far, this face is inclined for the reason that the pressure exerted on the pile edges by the separator is to be converted into a downwards movement of the rails carrying the sheets, so that the last (lowermost) sheet to be separated is reliably positioned on the support and in front of the blocking face.

In order to permit such an advantageous configuration of the transporter face of the shoe, the construction according to Figs 62 to 64 is selected.

The shoe 502 has an inclined face 504 along which, as in the previous forms of embodiment, the sheet edges are conveyed to the support 506. The second lowermost sheet 508 is provided with a separate transporter face 510 extending at right angles to the support plane, the height of which transporter face is clearly less than the thickness of one sheet so that at the start of the withdrawal movement the entire pile, including the sheet 512 to be separated, is transported along the blocking face 514. (Fig. 62).

As soon as the transporter face 510 passes over the step 516 which separates the blocking face from the support, the entire pile is displaced further downwards by the height of this step, the sheet 508 positioning the lowermost sheet 512 behind the step. The step 516 has a height exceeding the thickness of one sheet and less than the thickness of two sheets. The best compromise is to make the sum of the heights of the step 516 and the transporter face 510 equal to the thickness of two sheets. The bottom surface 518 of the shoe which extends parallel to the support ensures that the



sheet 512 is positioned flat on the support and that the sheet 508 is reliably presented to the transporter face 510.

As shown in Fig. 64, the lower edges of the shoe lying one behind the other are offset in relation to the small roller such that the edge cannot ride on the sheet 508 despite a maximum inclined position of the rail (about  $7^{\circ}$ ) and cannot lift the roller away from the sheet 512, which would impair the clamping function thereof.

A further modification of this principle is illustrated in Fig. 65. The step 600 between the blocking face 604 and support 602 has a height that is somewhat greater than the thickness of two sheets. The shoe again has its own transporter face 606 for the lowermost sheet 608, which rests not on the blocking face 604, but hangs down between the two ribs carrying the blocking faces, so that only the lowermost sheet 610 remains positioned on the support 602 while the sheet 608 is taken along. This construction has the advantage that all the sheet edges are pressed as far as the step 600 in the direction of the housing base and both lowermost sheets are reliably positioned behind the step 600. For this reason the transporter face is set back with respect to the end edge of the inclined face since the displacement of the sheets 608, 610 to behind the step 600 requires a certain stroke. The horizontal roofing 612 calibrates the aperture and holds sheet 610 reliably on the support.

Since both sheets 608, 610 are braked, not only is sheet 610 held firmly at its other end by means of a hook but also sheet 608 too, which, however, must be released again. For this reason only a braking hook and not an arresting hook is suitable, for example as shown in Fig. 1 at 126.

The construction shown in Fig. 66, in which the



transporter face for the second lowermost sheet directly adjoins the inclined face, is less suitable, for the reasons discussed above, but may function if the changer is operated relatively slowly.

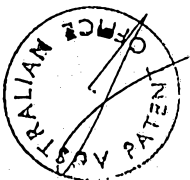

The claims defining the invention are as follows:

1. A device for cyclic rearrangement of a pile of substantially rectangular sheets, comprising

a first frame part and a second frame part,

a viewing window in one of said frame parts,

said second frame part being reciprocable relative to said first frame part between an inner end position and an outer end position over a stroke limited by stop means,

means for removing a sheet from a first end of a pile in the device when said second frame part is displaced from said inner end position to said outer end position and for adding said removed sheet to a second end of said pile when said second frame part is displaced from said outer end position back to said inner end position, said removing and adding means including transfer means for displacing said removed sheet from said first pile end toward said second pile end,

spring-biased pressing means for pressing said pile towards said viewing window when said second frame part is in said inner end position, said pressing means including two rail elements made of plastics material, said rail elements being arranged symmetrically with respect to a central plane of symmetry extending in the direction of reciprocation of said second frame part, each rail element having a length substantially equal to said stroke, each rail element being supported by a leaf spring, each leaf spring having a first end fastened to said first frame part and a second end supported by said first frame part, each leaf spring being bowed between said first and second ends towards said viewing window and connected approximately midway between said first and second ends to said rail element allocated thereto, and a space being provided between said rail elements for accomodation of said transfer means.

2. A device for cyclic rearrangement of a pile of substantially rectangular sheets, comprising

a first frame part and a second frame part,

a viewing window in one of said frame parts,

said second frame part being reciprocable relative to said first frame part between an inner end position and an outer end position over a stroke limited by stop means,

means for removing a sheet from a first end of a pile in the device when said second frame part is displaced from said inner end position to



JLH/STA/332E

said outer end position and for adding said removed sheet to a second end of said pile when said second frame part is displaced from said outer end position back to said inner end position,

spring-biased pressing means for pressing said pile towards said viewing window when said second frame part is in said inner end position, said pressing means including two rail elements extending in reciprocation direction and having a length substantially equal to said stroke, said rail elements being supported on a spring, wherein said first frame part is a housing having said viewing window and, opposite thereto, a housing bottom, and said second frame part is a slider member telescopically reciprocable through a housing opening parallel to said viewing window, said rail elements being provided adjacent said housing opening with means for blocking the insertion of sheets between said at least one rail element and said housing bottom, and

each rail element being made of plastic material,

said rail elements being arranged symmetrically with respect to a plane of symmetry extending in the direction of reciprocation of said second frame part.

3. A device according to claim 2 wherein said blocking means are integrally moulded on a rail end adjacent said opening.

4. A device according to claim 2 wherein said blocking means comprise a projection directed towards said housing bottom.

5. A device according to claim 4 wherein said slider member has a transverse strut serving as a separator and running over said at least one rail element and in said outer end position, rests on said rail element close to an end thereof adjacent said opening and in this position said projection reaches almost to said housing bottom.

6. A device according to claim 2 wherein said blocking means are movably joined to said rail element.

7. A device according to claim 6 wherein said blocking means comprise a flap hinged to a rail end adjacent said opening, a free flap end being guided on said housing.

8. A device according to claim 6 wherein said free flap end is guided in a sliding manner on said housing bottom in direction of reciprocation of said slider member.

9. A device according to claim 2 wherein said slider member has surface portions opposite said viewing window and supporting said pile of



sheets wherein said blocking means define a level parallel to said viewing window which is further away from said window than said pile-supporting surfaces of said slider member.

10. A device according to claim 4 wherein said projection is inclined towards said housing opening and housing bottom.

11. A device according to claim 2 wherein blocking elements for guiding sheet edges over said blocking means are integrally moulded on said housing bottom.

12. A device for cyclic rearrangement of a pile of substantially rectangular sheets, comprising

a first frame part and a second frame part,

a viewing window in one of said frame parts,

said second frame part being reciprocable relative to said first frame part between an inner end position and an outer end position over a stroke limited by stop means,

means for removing a sheet from a first end of a pile in the device when said second frame part is displaced from said inner end position to said outer end position and for adding said removed sheet to a second end of said pile when said second frame part is displaced from said outer end position back to said inner end position,

spring-biased pressing means for pressing said pile towards said viewing window when said second frame part is in said inner end position, said pressing means including two rail elements extending in reciprocation direction and having a length substantially equal to said stroke, said rail elements being supported on a spring, wherein said first frame part is a housing having said viewing window and, opposite thereto, a housing bottom, and said second frame part is a slider member telescopically reciprocable through a housing opening parallel to said viewing window, said rail elements having a first end adjacent said housing opening and a second end remote from said housing opening, said slider member having a pile transporter passing over said rail element upon slider member reciprocation and in said outer end position presses said first rail element end away from said viewing window, said housing having means for depressing, upon each slider reciprocation, said second rail element end away from said viewing window whereby, each time said slider is in said outer end position, said rail elements assume a position substantially parallel to said viewing window, said depressing means being respectively activated and deactivated in response to each



41H/STA/332E

slider reciprocation, and

each rail element being made of plastic material,  
said rail elements being arranged symmetrically with respect to a  
plane of symmetry extending in the direction of reciprocation of said  
second frame part.

13. A device according to claim 12 wherein said depressing means  
enter into operative engagement with said second rail element end.

14. A device according to claim 13 wherein said depressing means  
comprise anchoring hooks integrally moulded on said housing beneath which  
hooks said second rail element end is displaceable as said slider member  
is displaced towards said outer end position, and from which it is  
releasable as said slider member is displaced towards said inner end  
position.

15. A device according to claim 12 wherein said depressing means  
define a level of a side of said rail element facing towards said viewing  
window, said level lying beneath said pile transporter.

16. A device according to claim 12 wherein said pile of sheets is  
supported with respect to said viewing window on faces of said slider  
member that are parallel to said viewing window and wherein a  
window-facing side of said rail element lies approximately flush with  
said faces when said slider member is in said outer end position.

17. A device according to claim 14 wherein said rail element is  
displaceable in engagement with said anchoring hooks by performing a  
tilting motion about an end of its supporting spring upon displacement of  
said slider member from said inner end position towards said outer end  
position.

18. A device according to claim 13 wherein anchoring hooks are  
arranged displaceably on said housing, said hooks being displaced in  
engagement with said rail element end as the slider member is displaced  
from said inner towards said outer end position, and said hooks being  
displaced into a disengaging position as said slider member is displaced  
from said outer towards said inner end position.

19. A device according to claim 18 wherein said anchoring hooks  
are displaceable towards said housing opening.

20. A device according to claim 18 wherein said anchoring hooks  
are spring-biased into their engaging position.

21. A device according to claim 20 wherein said anchoring hooks  
are part of a resilient member.



JLH/STA/332E

22. A device according to claim 18 wherein said anchoring hooks are pivotally movable.

23. A device according to claim 14 or 17, wherein said second rail element end is first of all depressed to a level below said anchoring hooks and then raised until it enters into engagement with said hooks.

24. A device for cyclic rearrangement of a pile of substantially rectangular sheets, comprising

a first frame part and a second frame part,

a viewing window in one of said frame parts,

said second frame part being reciprocable relative to said first frame part between an inner end position and an outer end position over a stroke limited by stop means,

means for removing a sheet from a first end of a pile in the device when said second frame part is displaced from said inner end position to said outer end position and for adding said removed sheet to a second end of said pile when said second frame part is displaced from said outer end position back to said inner end position,

spring-biased pressing means for pressing said pile towards said viewing window when said second frame part is in said inner end position, said pressing means including two rail elements extending in reciprocation direction and having a length substantially equal to said stroke, said rail elements being supported on a spring, wherein said first frame part is a housing having said viewing window and, opposite thereto, a housing bottom, and said second frame part is a slider member telescopically reciprocable through a housing opening parallel to said viewing window, said rail elements having a first end adjacent said housing opening and a second end remote from said housing opening, said slider member having a pile transporter passing over said rail element upon slider member reciprocation, wherein said rail elements have means for engaging a transverse edge of said to-be-removed sheet while remaining sheets of said pile are passed across said engaging means by said pile transporter, and

each rail element being made of plastic material,

said rail elements being arranged symmetrically with respect to a plane of symmetry extending in the direction of reciprocation of said second frame part.

25. A device according to claim 24 wherein said engaging means comprise at least one projection which projects beyond a side of said



rail element facing toward said pile of sheets.

26. A device according to claim 25 including a pair of projections arranged symmetrically on said at least one rail element.

27. A device according to claim 25 wherein said projection has an inclined face facing towards the pile of sheets.

28. A device according to claim 25 wherein said projection has an inclined face facing away from the pile of sheets.

29. A device according to claim 25 wherein said projection protrudes beyond said rail element side by an amount exceeding a thickness of one sheet.

30. A device according to claim 25 wherein said projection is integrally formed with said rail element.

31. A device according to claim 25 wherein said pile transporter includes a transverse strut overrunning said projection as said slider member is displaced from said inner towards said outer end position and said strut having apertures for passage of said projection.

32. A device according to claim 25 wherein said projection comprises a hook extending substantially at right angles to the plane of the to-be-removed sheet, the height of said hook being less than a thickness of one sheet.

33. A device according to claim 32 wherein said hook is located at an end of a plateau substantially parallel to the plane of the to-be-removed sheet.

34. A device according to claim 32 wherein a sloping ramp is provided in front of said hook.

35. A device according to claim 34 wherein said ramp is provided on a hook-side half of said rail element.

36. A device according to claim 34 wherein said rail element carries a retentive covering strip which lies on a support ramp parallel with said sloping ramp.

37. A device according to claim 25 wherein on both sides of a retentive strip applied to said rail element there is provided one projection spaced from said strip.

38. A device according to claim 24 in which on a housing wall facing said rail element there are provided sheet holding-down members in overlapping relation with said engaging means.



39. A device according to claim 24 wherein said rail element projects beyond said engaging means.

40. A device for cyclic rearrangement of a pile of substantially rectangular sheets, comprising

a first frame part and a second frame part,

a viewing window in one of said frame parts,

said second frame part being reciprocable relative to said first frame part between an inner end position and an outer end position over a stroke limited by stop means,

means for removing a sheet from a first end of a pile in the device when said second frame part is displaced from said inner end position to said outer end position and for adding said removed sheet to a second end of said pile when said second frame part is displaced from said outer end position back to said inner end position,

spring-biased pressing means for pressing said pile towards said viewing window when said second frame part is in said inner end position, said pressing means including two rail elements extending in reciprocation direction, wherein said rail elements are provided with means for retaining said to-be-removed sheet, said retaining means including a strip frictionally engaging said to-be-removed sheet, said rail elements being further provided with spacer elements next to said strip, said second frame part having means for depressing said to-be-removed strip in engagement with said strip when said second frame part is displaced from said inner end position towards said outer end position, and remaining sheets of said pile riding on said spacer elements out of engagement with said strip when said second frame part is displaced from said outer end position towards said inner end position, and

each rail element being made of plastic material,

said rail elements being arranged symmetrically with respect to a plane of symmetry extending in the direction of reciprocation of said second frame part.

41. A device according to claim 40 wherein said strip is formed by a retentive covering strip.

42. A device according to claim 40 wherein said depressing element is provided on a transporter for said remaining sheets.

43. A device according to claim 42 wherein said depressing element is a rotatable roller.

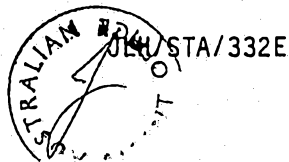

44. A device according to claim 40 wherein said depressing element is supported resiliently on a transporter for remaining sheets of said pile.

45. A device according to claim 40 wherein said spacer elements comprise upright ribs projecting away from said rail element.

46. A device according to claim 43 wherein said roller is mounted in a shoe which is guided in a sliding manner on said transporter.

47. A device according to claim 46 wherein said shoe has an edge remote from said viewing window on a level that is further removed from the viewing window than a level defined by said spacer elements where said to-be-removed sheet is clamped between said roller and said strip.

48. A device according to claim 47 wherein spacer ribs are provided on both sides of said shoe.

49. A device according to claim 40 wherein said spacer elements extend for a substantial part of the length of said rail element.

50. A device according to claim 40 or 49 wherein a rail element end adjacent a transporter for remaining sheets of said pile when said second frame part is in said inner end position has no spacer elements.

51. A device according to claim 41 wherein said rail element is injection-moulded from plastics material, said retentive covering strip is shorter than said rail element and is cut off obliquely at its ends, and wherein said rail element has a tolerance-compensating projection close to said oblique end of said covering strip, said projection having a height that increases transversely to said rail from a minimum, corresponding to a relatively thin covering strip, to a maximum, corresponding to a relatively thick covering strip.

52. A device for cyclic rearrangement of a pile of substantially rectangular sheets, comprising

a first frame part and a second frame part,

a viewing window in one of said frame parts,

said second frame part being reciprocable relative to said first frame part between an inner end position and an outer end position over a stroke limited by stop means,

means for removing a sheet from a first end of a pile in the device when said second frame part is displaced from said inner end position to said outer end position and for adding said removed sheet to a second end of said pile when said second frame part is displaced from said outer end position back to said inner end position,



spring-biased pressing means for pressing said pile towards said viewing window when said second frame part is in said inner end position, said pressing means including two rail elements extending in reciprocation direction, wherein said rail elements are provided with means for retaining said to-be-removed sheet, and said second frame part is provided with means for transporting remaining sheets of said pile, said retaining means for said to-be-removed sheet including a gripping element displaceable relative to said to-be-removed sheet so as to engage a side thereof facing said remaining sheets and to press it against said rail elements, the device further comprising means for controlling displacement of said gripping element in response to reciprocation of said second frame part, and

each rail element being made of plastic material,  
said rail elements being arranged symmetrically with respect to a plane of symmetry extending in the direction of reciprocation of said second frame part.

53. A device according to claim 52 wherein said gripping element is displaceable, in a direction in which said rail element extends, between a pressing and a releasing position.

54. A device according to claim 52 wherein said gripping element is displaceable by collision with said second frame part.

55. A device according to claim 52 wherein said gripping element has resiliently deflectable arms.

56. A device according to claim 52 wherein said gripping element is controlled by collision with remaining sheets of said pile.

57. A device according to claim 52 wherein said gripping element is separable from said to-be-removed sheet when said second frame part is displaced towards said inner end position.

58. A device according to claim 52 wherein said gripping element is spring-biased into one of two end positions.

59. A device according to claim 52 wherein said gripping element is displaced into a pressing position once said transporting means has passed over a transverse edge of the to-be-removed sheet.

60. A device according to claim 52 wherein said gripping element engages an individual sheet end over which said transporting means passes last.

61. A device according to claim 60 comprising means for lifting said remaining sheets so as to allow a displacement of said gripping



element in engagement with said to-be-removed sheet.

62. A device for cyclic rearrangement of a pile of substantially rectangular sheets, comprising

a first frame part and a second frame part,

a viewing window in one of said frame parts,

said second frame part being reciprocable relative to said first frame part between an inner end position and an outer end position over a stroke limited by stop means,

means for removing an individual sheet from a first end of a pile in the device when said second frame part is displaced from said inner end position to said outer end position and for adding said individual removed sheet to a second end of said pile when said second frame part is displaced from said outer end position back to said inner end position,

a first retaining element for said individual sheet in said first frame part,

a second retaining element for remaining sheets of said pile in said second frame part,

wherein said first retaining element comprises stop elements engaged by a transverse edge of said individual sheet and comprising further gripping elements adapted to be positioned on a side of said individual sheet facing towards said remaining sheets and projecting between said individual sheet and said remaining sheets, and

wherein said stop elements and gripping elements are mounted on a pair of rail elements made of plastic material and each supported on a spring, said rail elements extending substantially over a reciprocation stroke and being symmetrically disposed with respect to a plane of symmetry extending in the direction of reciprocation.

63. A device according to claim 62 wherein said first retaining element is arranged on a rail element which presses said pile towards said viewing window when said second frame part is in said inner end position.

64. A device according to claim 62 wherein said first retaining element can be switched between a retaining and a releasing position through running over of said second frame part.

65. A device according to claim 62, 63 or 64 wherein said first gripping element holds said individual sheet until said second frame part has reached its outer end position.



66. A device according to claim 62 including means for lifting said remaining sheets so as to allow introduction of said gripping member between said individual sheet and said remaining sheets.

67. A device for cyclic rearrangement of a pile of substantially rectangular sheets having substantially identical thickness, comprising  
a first frame part and a second frame part,  
a viewing window in one of said frame parts,  
said second frame part being reciprocable relative to said first frame part between an inner end position and an outer end position,

means for removing an individual sheet from a first end of a pile in the device when said second frame part is displaced from said inner end position to said outer end position and for adding said removed sheet to a second end of said pile when said second frame part is displaced from said outer end position back to said inner end position,

spring-biased pressing means for pressing said pile towards said viewing window when said second frame part is in said inner end position, said pressing means including two rail elements extending in reciprocation direction, said rail elements being supported on a spring, wherein said pressing means is mounted in said first frame part,

a first separating element being stationarily provided in said first frame part, said first separating element cooperating with a second separating element provided on said second frame part to define upon reciprocation start a passage gap for separation of said individual sheet from remaining sheets of said pile,

said second separating element upon further displacement of said second frame part running onto said individual sheet supported by said rail elements so as to form in cooperation with said pressing means a barrier which blocks passage of further ones of said remaining sheets, and each rail element being made of plastic material,

said rail elements being arranged symmetrically with respect to a plane of symmetry extending in the direction of reciprocation of said second frame part.

68. A device according to claim 67 wherein said second frame part has a transverse strut for transporting said remaining sheets, said strut carrying said second separating element.

69. A device according to claim 67 wherein said first and second separating elements are biased resiliently towards one another at least during reciprocation start.

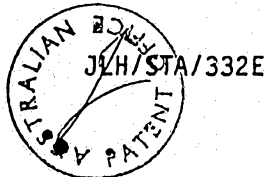

70. A device according to claim 69 wherein on said transverse strut there are arranged displaceable shoes which are supported against said strut by springs.

71. A device according to claim 68 wherein said first separating element comprises a step of a height that is greater than the thickness of one sheet and less than the thickness of two sheets.

72. A device according to claim 71 wherein adjoining said step in a direction opposing a withdrawal displacement of said second frame part there is a blocking face on which said second separating element can be positioned.

73. A device according to claim 72 wherein adjoining said step in said withdrawal displacement direction there is a positioning face for said individual sheet.

74. A device according to claim 67 wherein at least one of said first and second separating elements is provided with tapering run-on faces.

75. A device according to claim 67 wherein said first separating element is provided on ribs which extend in the direction of reciprocation of said second frame part.

76. A device according to claim 75 comprising at least one pair of congruent ribs.

77. A device according to claim 67 wherein cooperating first and second separating elements are provided on both sides of a plane of symmetry extending in the direction of reciprocation of said second frame part.

78. A device according to claim 70 wherein in said inner end position of said second frame part said shoe co-operates with an inclined face thereby locking said second frame part with respect to said first frame part.

79. A device according to claim 67 wherein said second separating element includes a small roller which protrudes beyond an operative edge of said second separating element by less than the thickness of one sheet.

80. A device according to claim 79 wherein said first separating element has a recess such that said small roller is relieved of stress when said second frame part is in said inner end position.

81. A device according to claim 67 wherein in reciprocation direction said rail element is aligned with said first and second separating elements.

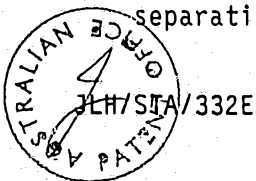

82. A device according to claim 81 wherein said rail element has an end that, comb-like, engages with said first separating element.

83. A device according to claim 67 wherein said second separating element is disposed on a transversely extending separator strut of said second frame part, said strut having surface portions defining an acute angle with a principal plane of the pile, which surface portions, as said second frame part is displaced from said inner towards said outer position, run onto an end of said rail element and displace said end towards said first separating element.

84. A device according to claim 83 wherein said rail element end is displaceable to such an extent that said individual sheet is deposited on a positioning surface.

85. A device according to claim 84 wherein said rail element end is displaceable to such an extent that said second separating element is able to run onto the positioned individual sheet.

86. A device according to claim 83 wherein said rail element end has thickened control prongs onto which said strut runs.

87. A device according to claim 86 wherein said rail element end has a central prong onto which a small roller provided on said second separating element runs.

88. A device according to claim 86 wherein said prongs define a first level for said rail element end from which said rail element end is further displaced by an on-running small roller.

89. A device according to claim 87 wherein in continuation of said central prong there is applied to said rail element a retentive covering on which said small roller is able to roll.

90. A device according to claim 67 comprising means for depressing said rail element are provided adjacent said first separating element.

91. A device according to claim 67 wherein said rail element is supported on a leaf spring having an end adjacent said first separating element.

92. A device according to claim 67 wherein said first separating element is integrally moulded with a bottom of said first frame part opposite said viewing window.

93. A device for cyclic rearrangement of a pile of substantially rectangular sheets having substantially identical thickness, comprising a first frame part and a second frame part, said second frame part being reciprocable relative to said first



frame part between an inner end position and an outer end position,  
means for removing an individual sheet from a first end of a pile  
in the device when said second frame part is displaced from said inner  
end position to said outer end position and for adding said removed sheet  
to a second end of said pile when said second frame part is displaced  
from said outer end position back to said inner end position,

said means for removing and adding including first means for  
retaining said individual sheet in said first frame part and second means  
for retaining remaining sheets of said pile in said second frame part,

said first retaining means including a hook portion adapted to  
engage an end edge of said individual sheet,

wherein for disabling of the rearrangement, means are provided for  
guiding said end edge of said individual sheet over said hook portion so  
that said individual sheet is retained by said second retaining means  
together with said remaining sheets, and

wherein said hook portions are provided on a pair of rail elements  
made of plastic material and each supported on a spring, said rail  
elements extending substantially over a reciprocation stroke and being  
symmetrically disposed with respect to a plane of symmetry extending in  
the direction of reciprocation.

94. A device according to claim 93 wherein rearrangement can be  
manually disabled.

95. A device according to claim 93 including a removal gap through  
which, upon normal rearrangement, said individual sheet passes, and  
including means for blocking said gap at least during an initial phase of  
displacement of said second frame part from said inner end position  
towards said outer end position.

96. A device according to claim 95 wherein said guiding means and  
said blocking means can be simultaneously activated so as to disable  
rearrangement.

97. A device according to claim 93 wherein said first frame part  
is a housing having a viewing window and said second frame part is a  
slider member telescopically reciprocable relative to said housing, a  
first separating element for said individual sheet being provided on said  
housing, a second separating element for said individual sheet being  
provided on said slider member, said first and second separating elements  
defining a removal gap for said individual sheet, means for pressing said  
pile of sheets towards said viewing window when said second frame part is



in said inner end position, and said hook portion being provided on said pressing means.

98. A device according to claim 97 wherein said pressing means comprises at least one rail element spring supported on said housing, and said slider member having a transverse strut carrying said second element and running onto said rail element.

99. A device according to claim 97 wherein said second retaining means includes an inner end wall of said slider member, said end wall carrying said second separating element.

100. A device according to claim 97 wherein said hook portion is arranged on an end of said rail element adjacent a housing opening through which said slider member reciprocates.

101. A device according to claim 93 wherein said guiding means comprise a guide element, and said hook portion and said guide element being displaceable relative to one another.

102. A device according to claim 101 wherein said guide element is manually relative to said hook portion.

103. A device according to claim 102 wherein said hook portion is immovably connected to a sheet-supporting element and said guide element is movable to protrude out of said sheet-supporting element.

104. A device according to claim 103 wherein said guide element has a guide-way for said individual sheet end edge.

105. A device according to claim 103 wherein said guide element is displaceable relative to a rail element that forms said sheet-supporting element.

106. A device according to claim 105 wherein said guide element is displaceable along said rail element.

107. A device according to claim 101 wherein said first frame part has a bottom opposite a viewing window, and said guide element is activatable from said bottom.

108. A device according to claim 107 wherein said guide element can be brought into operative engagement with an actuating element through a movement of a hook portion carrying element relative to the housing.

109. A device according to claim 108 wherein said actuating element comprises a cam displaceable relative to said first frame part, a contacting portion of said guide element being adapted to collide with said contacting portion.



110. A device according to claim 108 wherein said actuating element also controls means for blocking a removal gap for said individual sheet.

111. A device according to claim 98 including two symmetrically arranged rail elements each having at least one hook portion with which a common actuating element is associated.

112. A device according to claim 107 wherein said bottom has an aperture through which an operating element for actuating said guide element projects outwards.

113. A device according to claim 112 wherein said operating element is displaceable in the direction of reciprocation of said second frame part.

114. A device according to claim 109 wherein said cam has an inclined control face along which said guide element is displaced in a sliding manner in the direction of reciprocation of said second frame part.

115. A device according to claim 106 wherein said guide element extends over a considerable part of said rail element.

116. A device according to claim 101 wherein said guide element is spring-biased into one of its end positions.

117. A device according to claim 116 wherein said guide element is spring-biased into an end position which enables rearrangement.

118. A device according to claim 98 wherein said rail element has a guide ramp along which a guide element is displaceable between a rearrangement disabling and enabling end position.

119. A device according to claim 101 wherein said guide element comprises a wire member.

120. A device according to claim 119 wherein said wire member is U-shaped and is open adjacent said hook portion.

121. A device according to claim 120 including two associated hook portions wherein each hook portion is assigned a free end of said wire member as guiding means.

122. A device according to claim 119 comprising longitudinal grooves in which each one of two parallel wire member arms is displaceable in a sliding manner.

123. A device according to claim 94 wherein manual disabling can be initiated only when said second frame part is in said inner end position.

124. A device according to claim 123 wherein said first frame part has an actuating element movable relative to it and means for locking



said actuating element in a position in which rearranging is disabled, and said locking means can be unlocked by control means on said second frame part.

125. A device according to claim 124 wherein after moving of said actuating element the latter is returnable to a rest position by said second frame part.

126. A device according to claim 124 wherein said actuating element comprises a locking portion which can be brought into locking engagement with said locking means and is disengageable by resilient deformation as it hits said second frame part.

127. A device according to claim 127 wherein resilient deformation is permitted only in specific relative positions of said actuating element with respect to said first frame part.

128. A device according to claim 127 wherein resilient deformation is effected only between two stable end positions.

129. A device according to claim 1 wherein said rail elements engage said sheets adjacent their edges lying parallel to displacement direction of said second frame part.

130. A device according to claim 1 wherein each rail element is supported on a metal spring.

131. A device according to claim 1 wherein said second leaf spring end is laterally supported.

132. A device according to claim 131 wherein said second leaf spring end is guided in a groove opposite said viewing window and extending in reciprocation direction.

133. A device according to claim 1 wherein said first leaf spring end is placed on a pin provided on the first frame part.

134. A device according to claim 1 wherein each rail element has reinforcing ribs on its side remote from the viewing window.

135. A device according to claim 1 wherein each rail element is of symmetrical construction with respect to its longitudinal central plane.

136. A device according to claim 1 wherein said second frame part has a grip recess which projects into a free space of said first frame part.

137. A device according to claim 136 wherein said grip recess is central with respect to a central plane of symmetry that extends in reciprocation direction.



138. A device according to claim 137 wherein between said grip recess and side walls of said second frame part there is provided a free space.

139. A device according to claim 138 wherein one rail element is provided on both sides of said central plane and projects with one end into one of said free spaces.

140. A device according to claim 138 wherein said free spaces extend for an entire height of the second frame part.

141. A device according to claim 67 wherein said second frame part has pile-supporting faces that are set back with respect to said second separating element in direction of displacement of said second frame part from said inner towards said outer end position.

142. A device according to claim 141 wherein ends of said pile-supporting faces are approximately flush with a part of said second separating element that projects outwards furthest.

143. A device according to claim 1 including auxiliary springs which form said transfer means.

144. A device according to claim 143 wherein said auxiliary springs are arranged in pairs.

145. A device according to claim 144 wherein said pairs of springs is disposed symmetrically with respect to reciprocation direction.

146. A device according to claim 143 wherein said auxiliary springs are arranged laterally next to said rail elements.

147. A device according to claim 146 wherein said auxiliary springs are arranged between said pair of rail elements.

148. A device for cyclic rearrangement of a pile of substantially rectangular sheets substantially as hereinbefore described with reference to the drawings.

DATED this TWELFTH day of JUNE 1991  
Licinvest AG

Patent Attorneys for the Applicant  
SPRUSON & FERGUSON



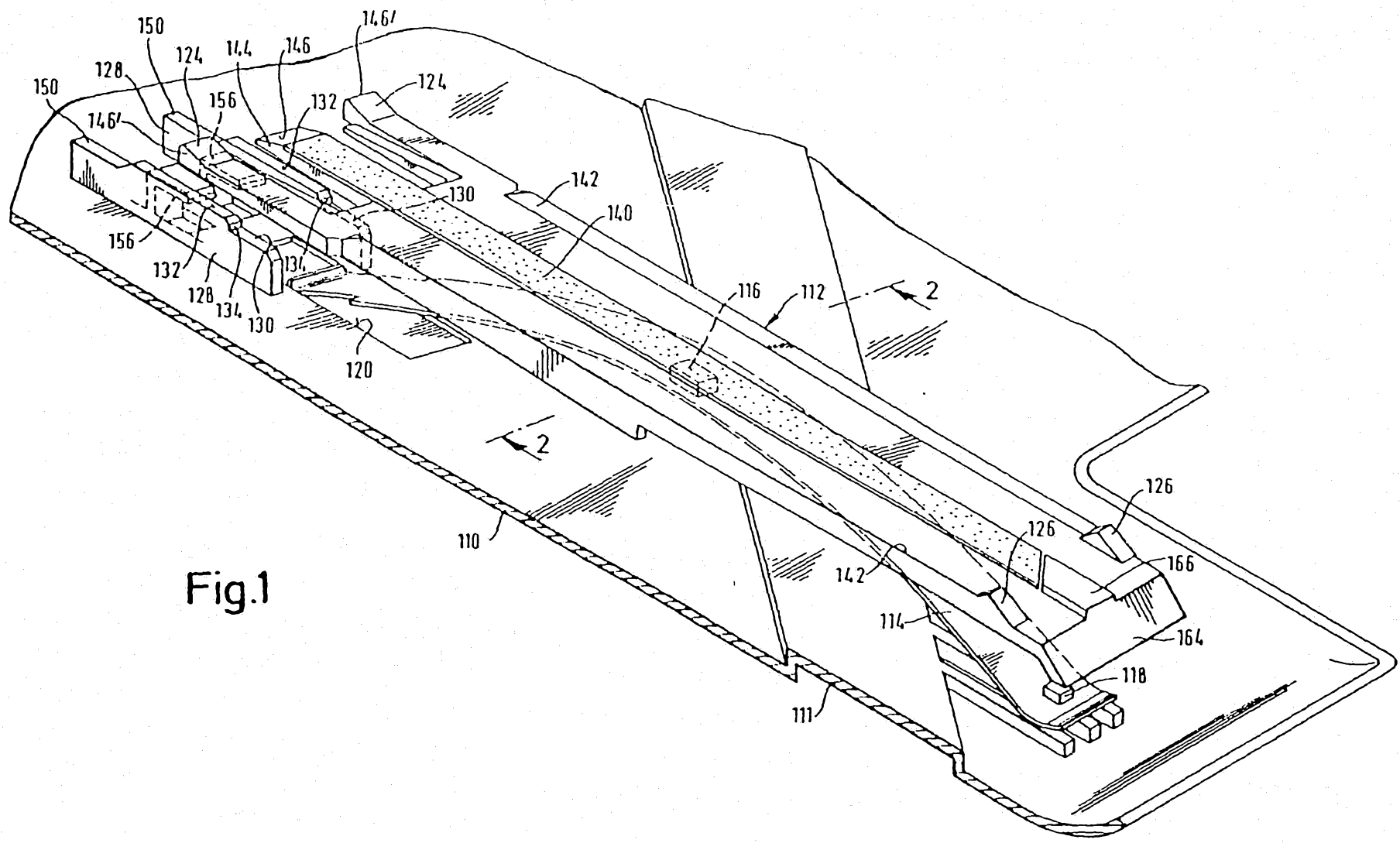

Fig. 1

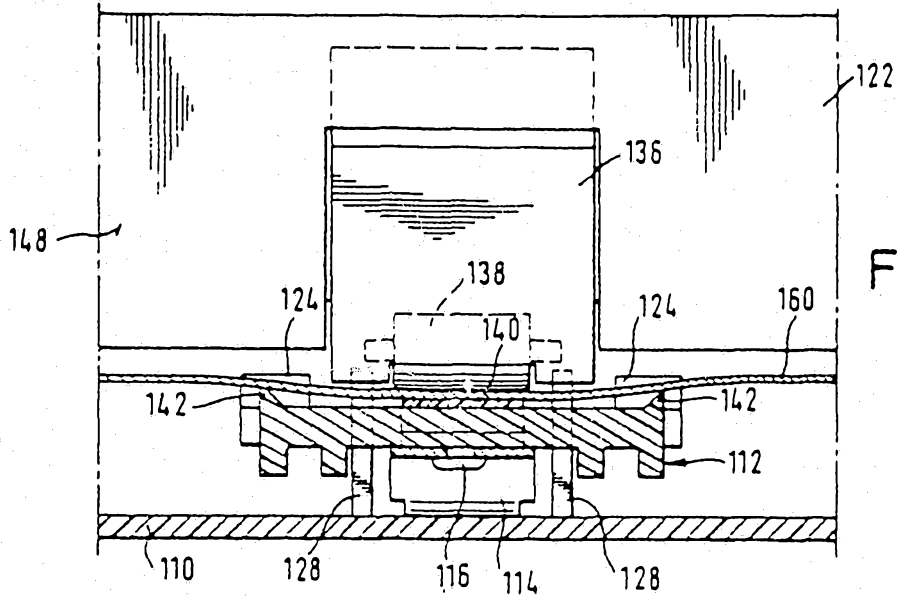

Fig. 2

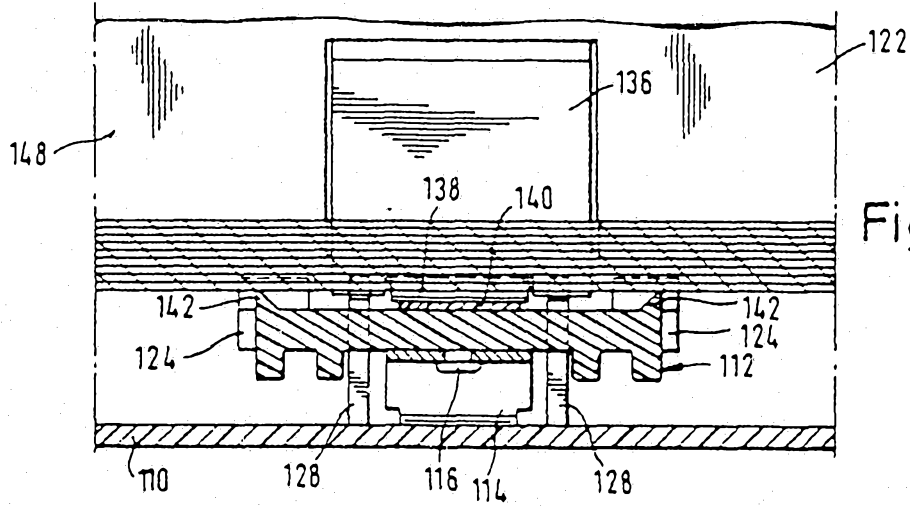

Fig. 5

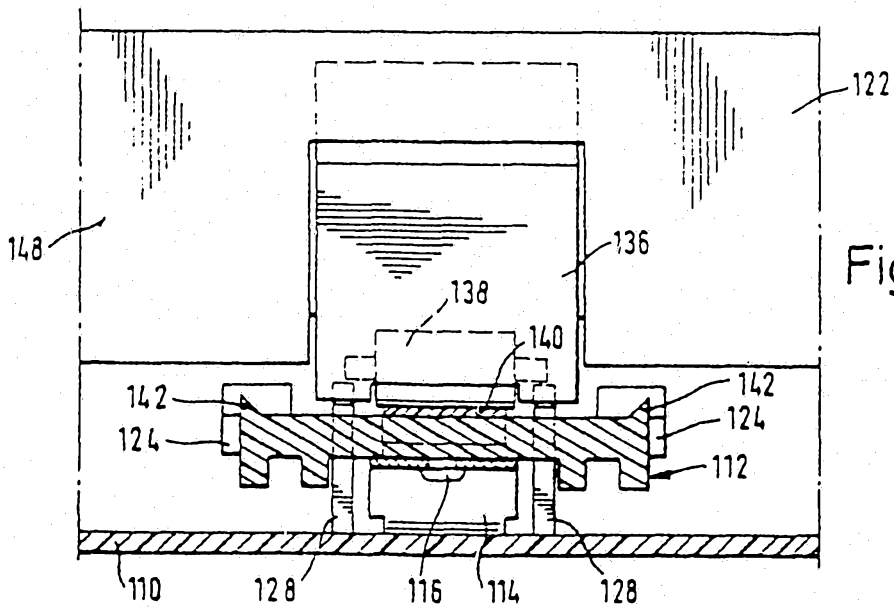

Fig. 6

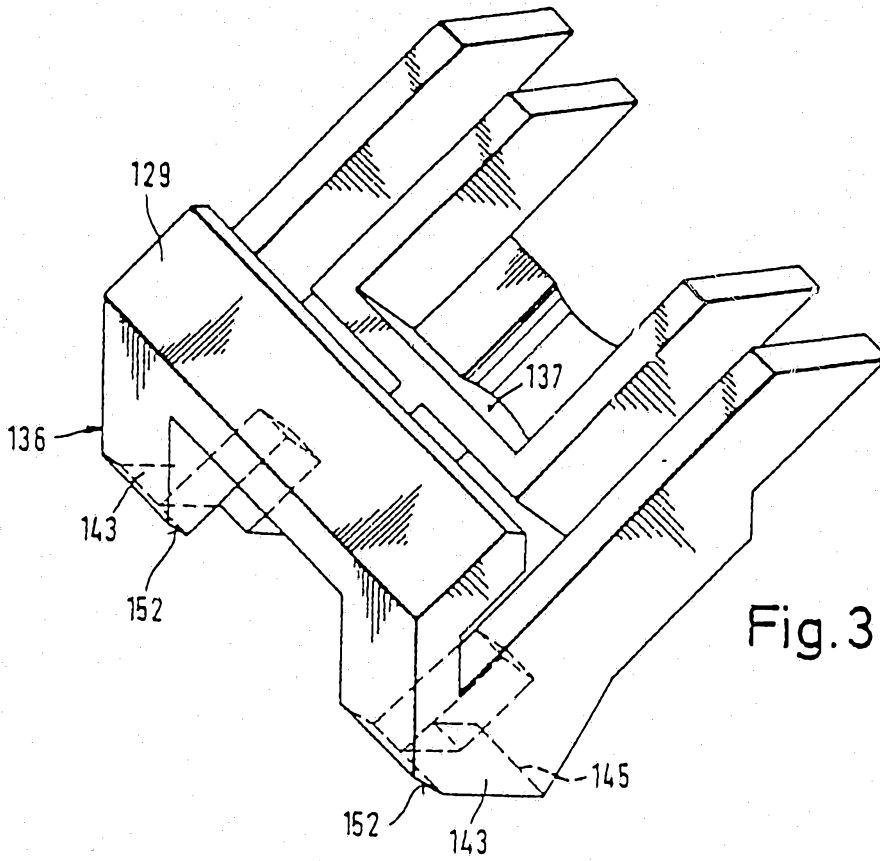

Fig. 3a

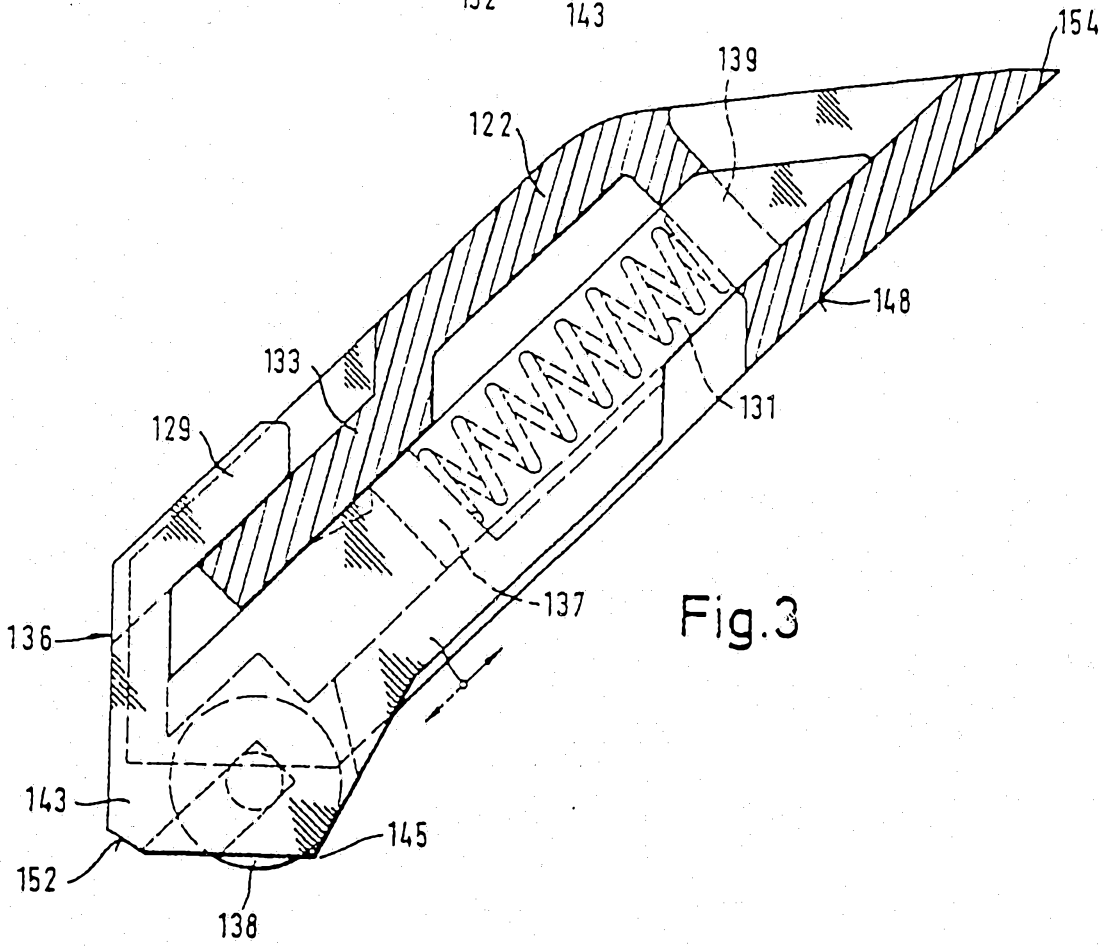

Fig. 3

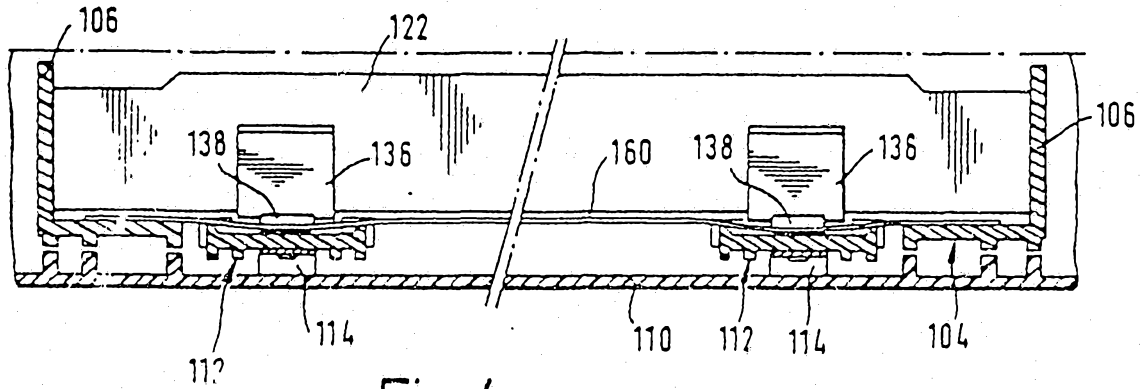

Fig. 4

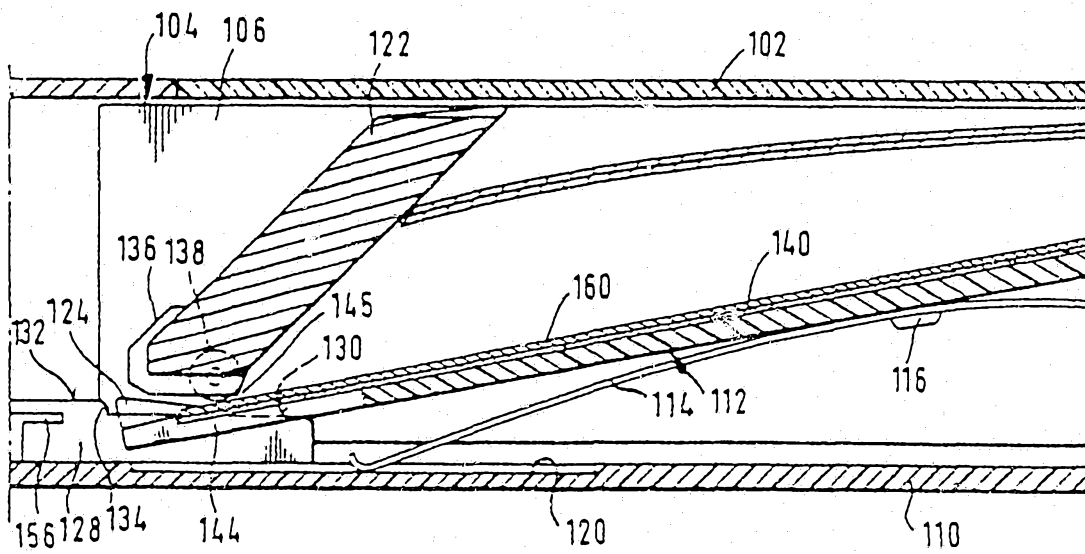

Fig. 7

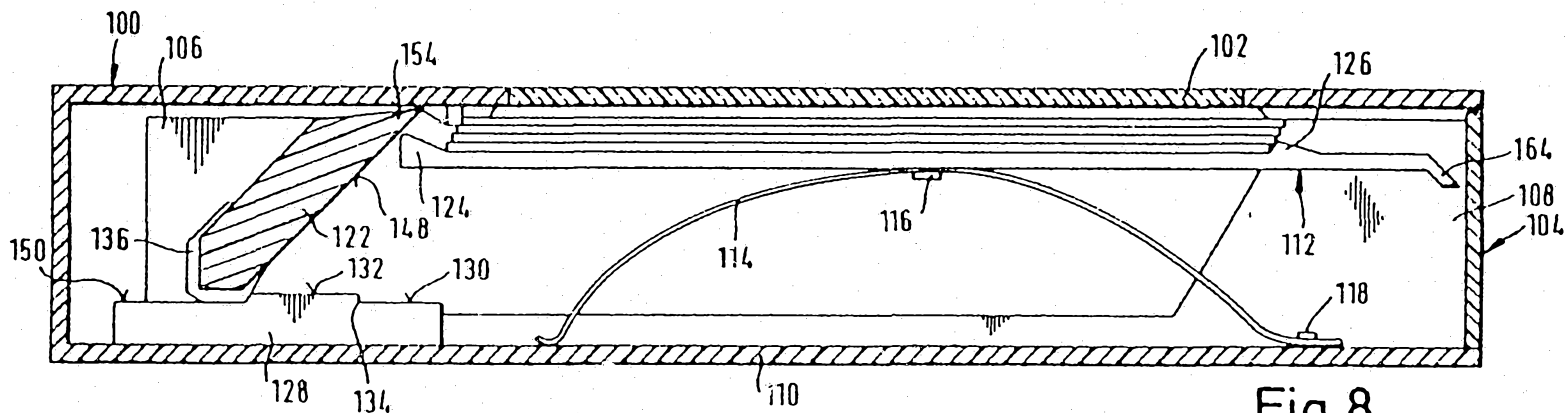

Fig. 8

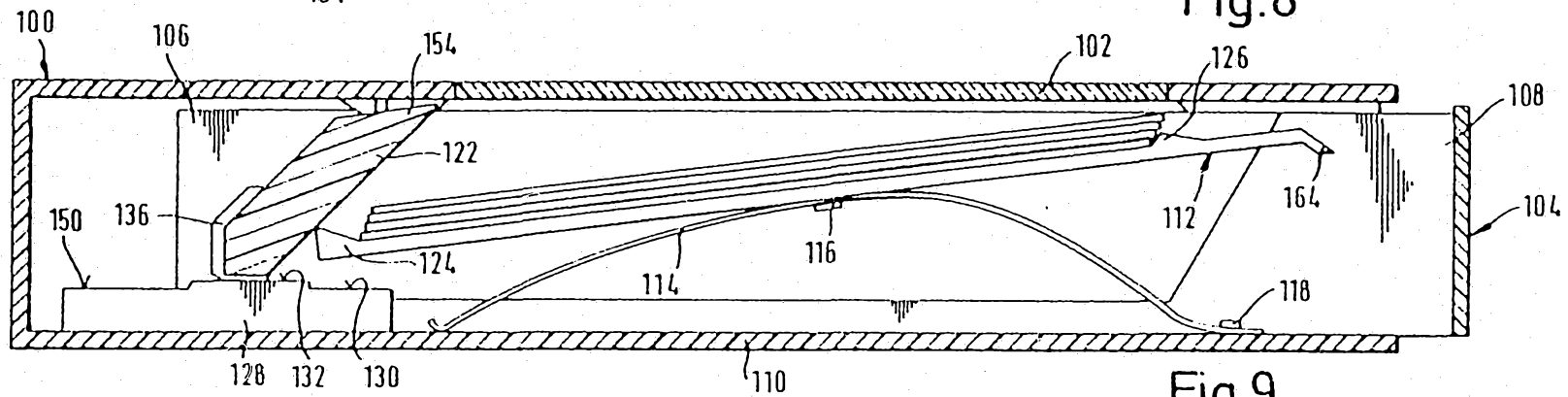

Fig. 9

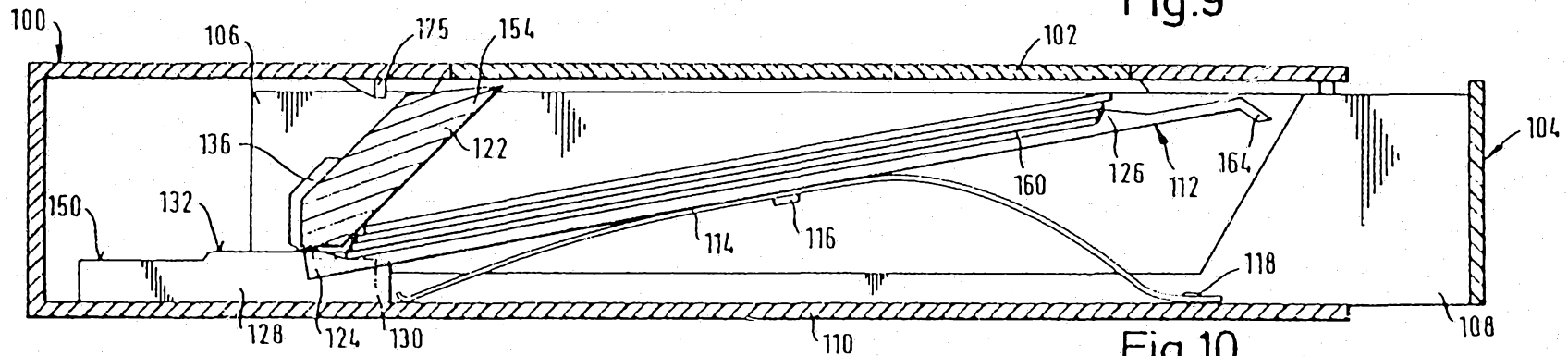

Fig. 10

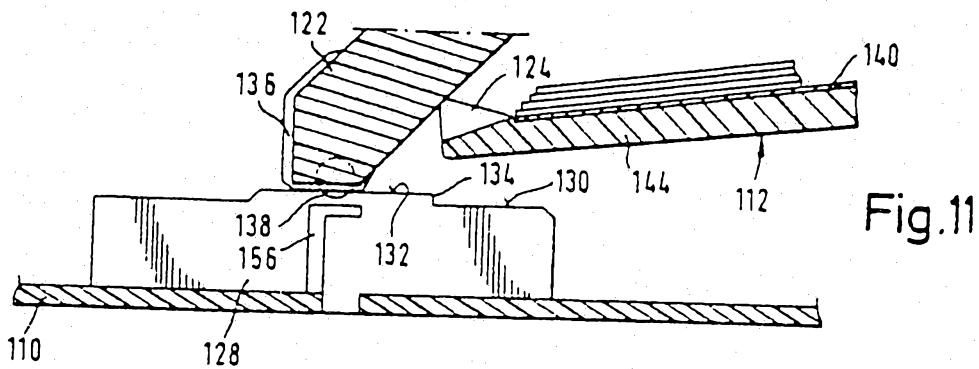

Fig. 11

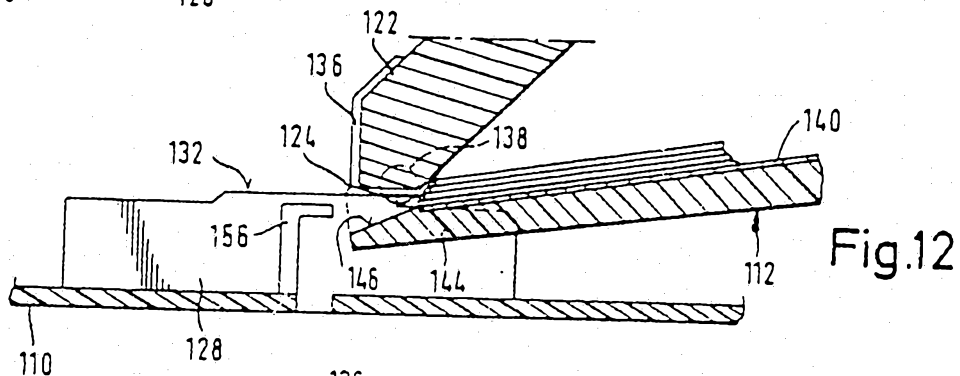

Fig. 12

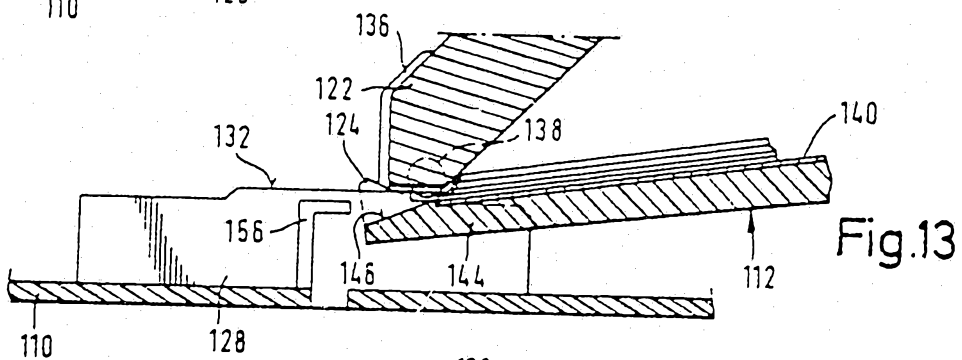

Fig. 13

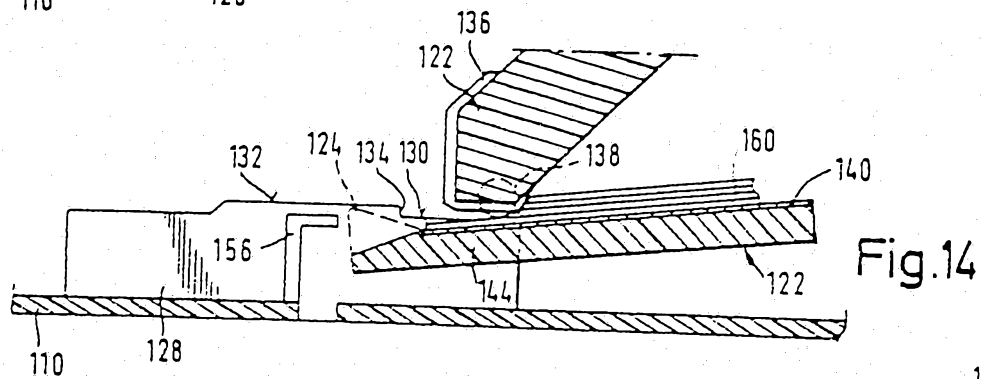

Fig. 14

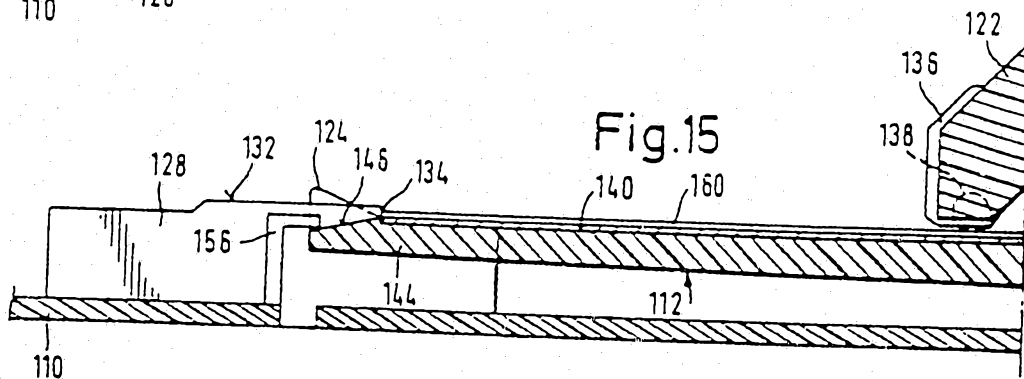

Fig. 15

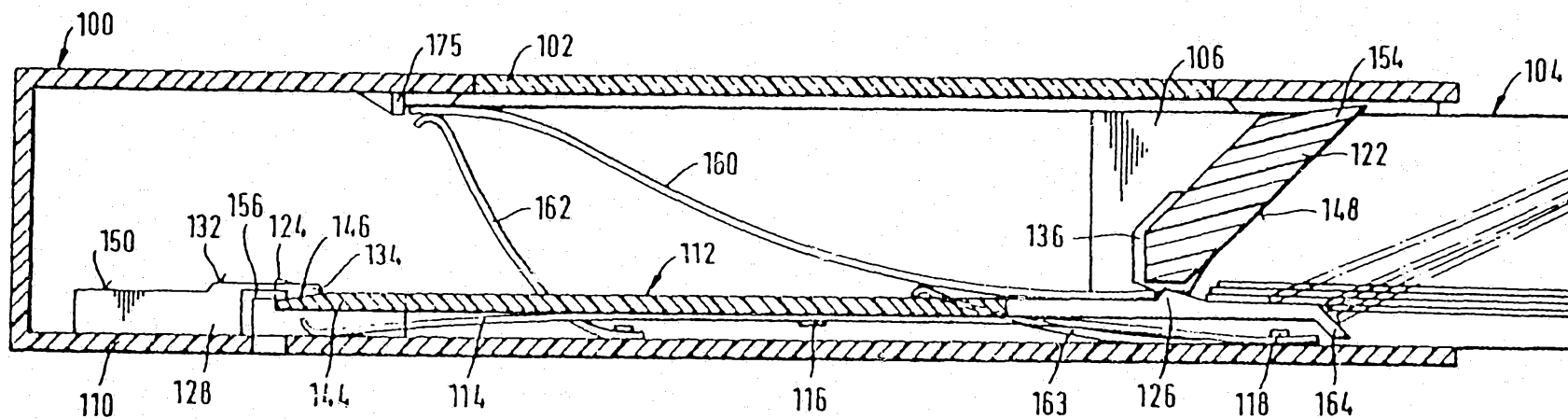

Fig.16

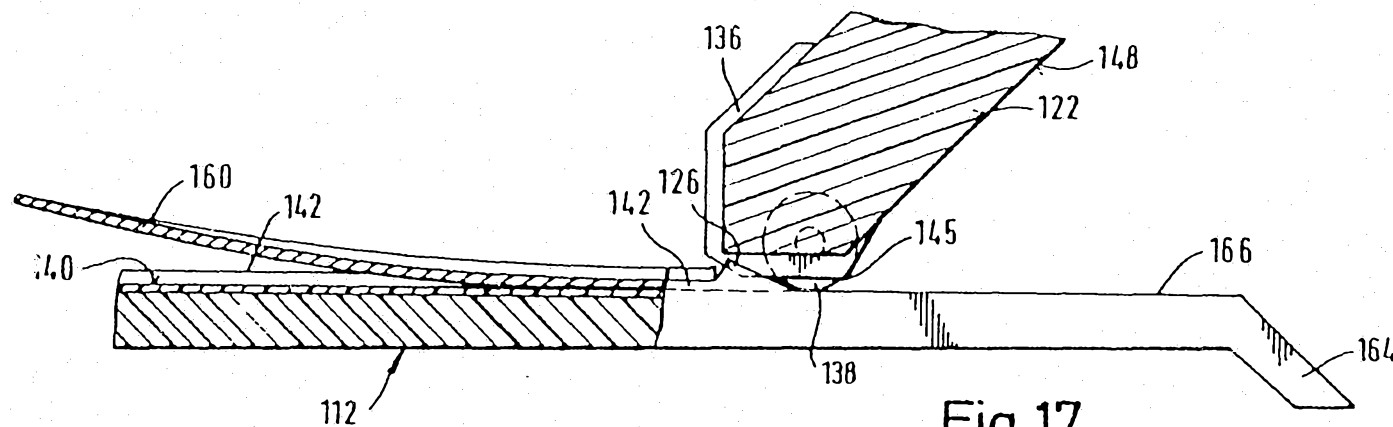
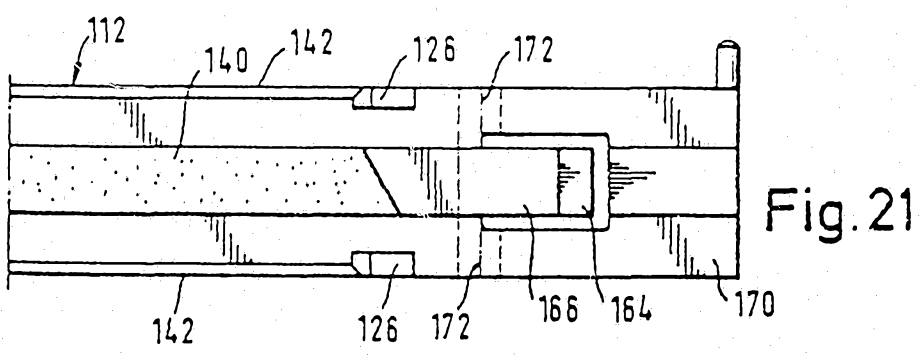
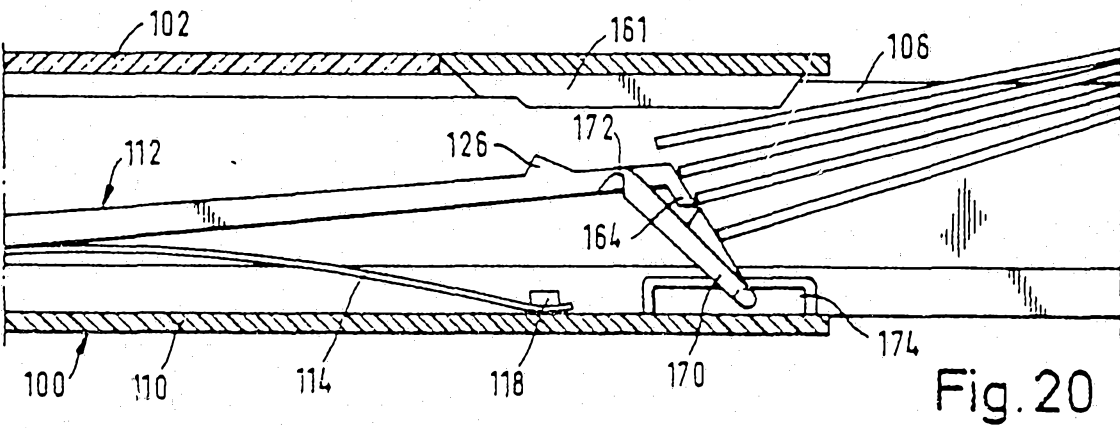
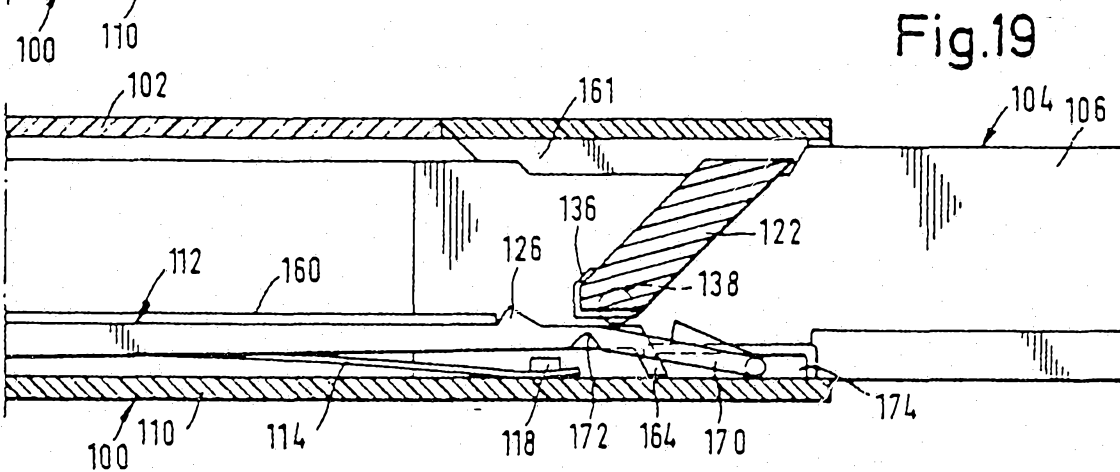
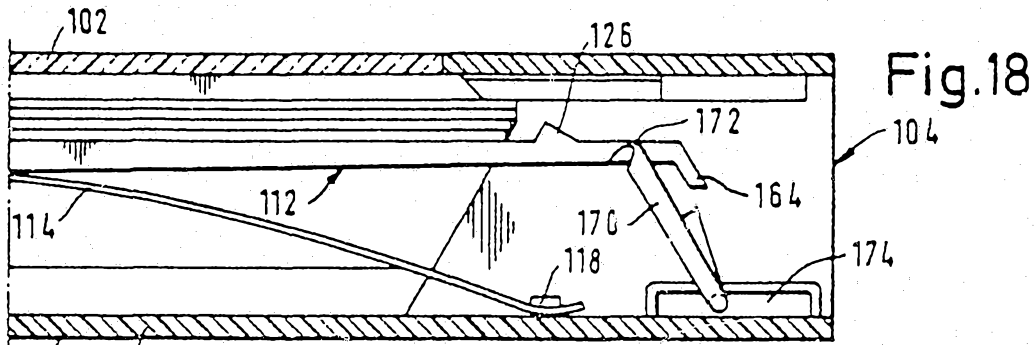

Fig.17



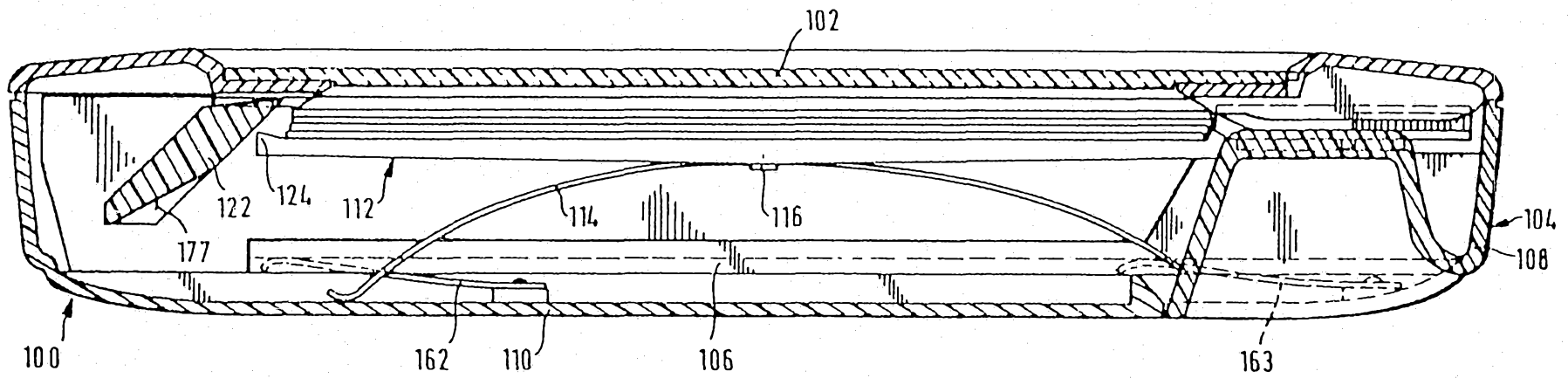

Fig. 22

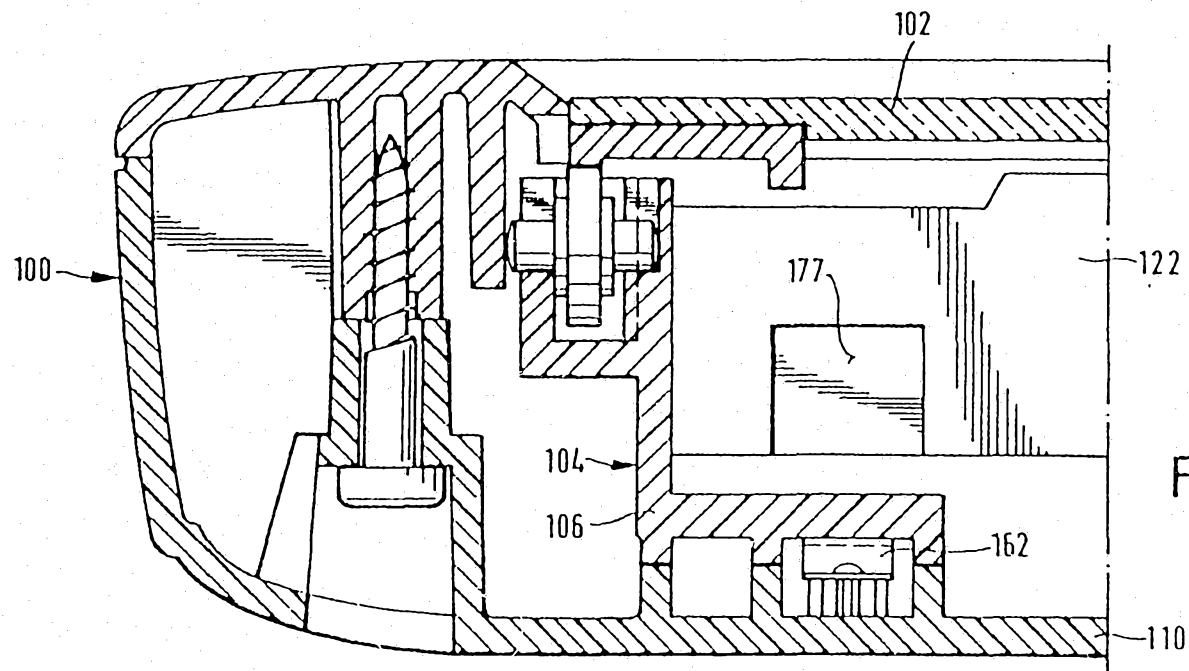

Fig. 23

Fig. 24

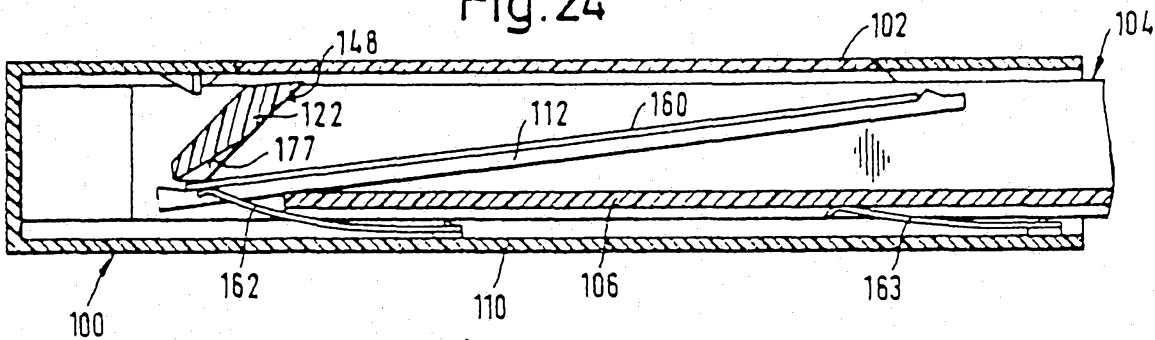

Fig. 25

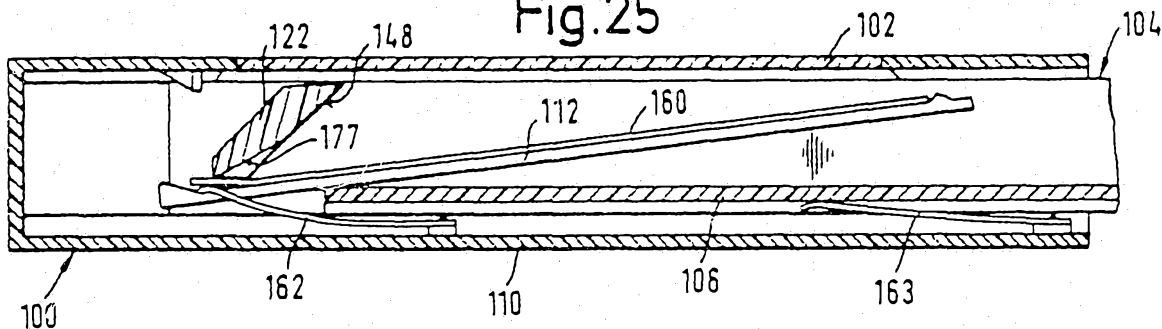

Fig. 26

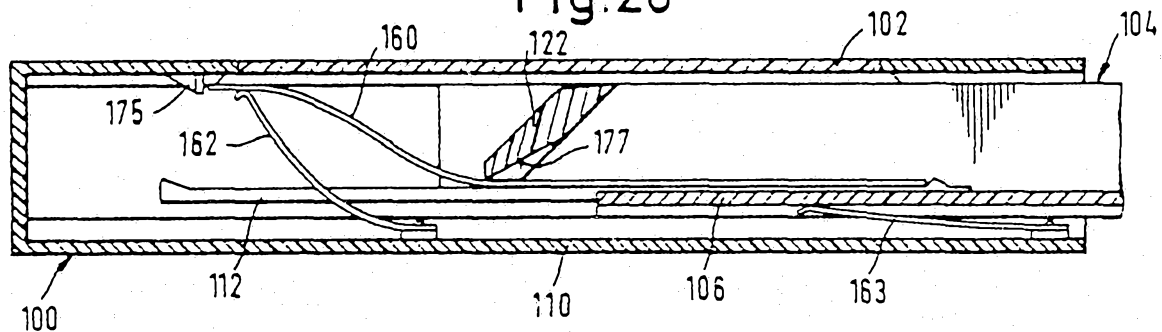

Fig. 27

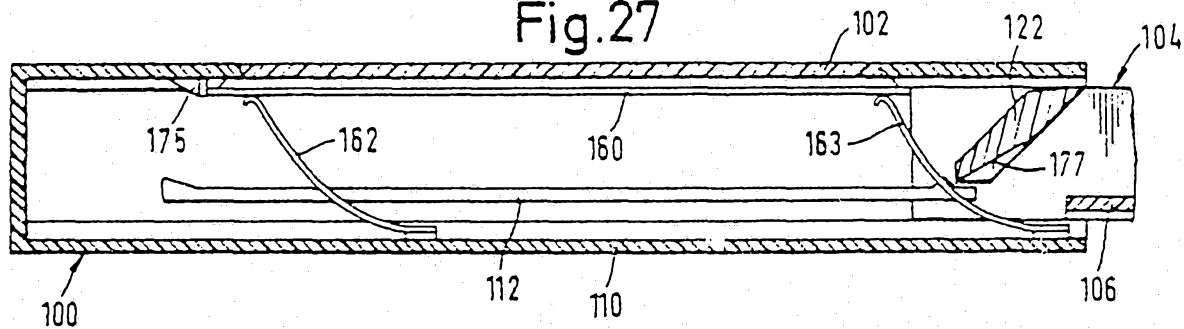

Fig.28

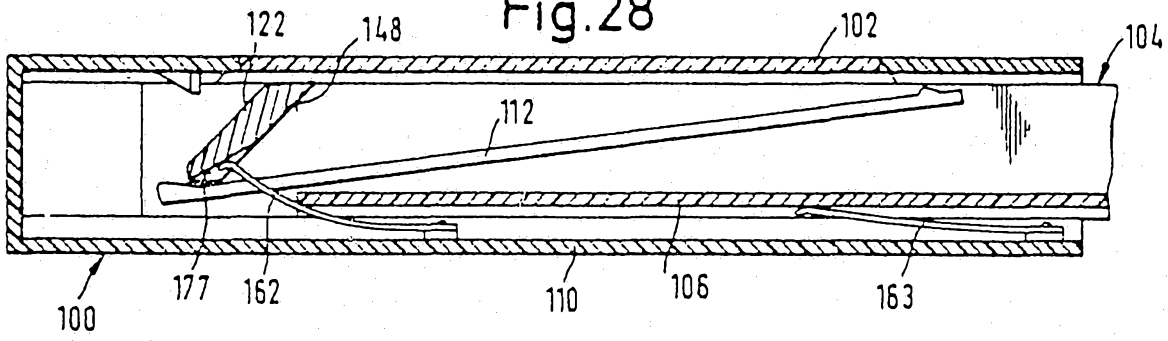
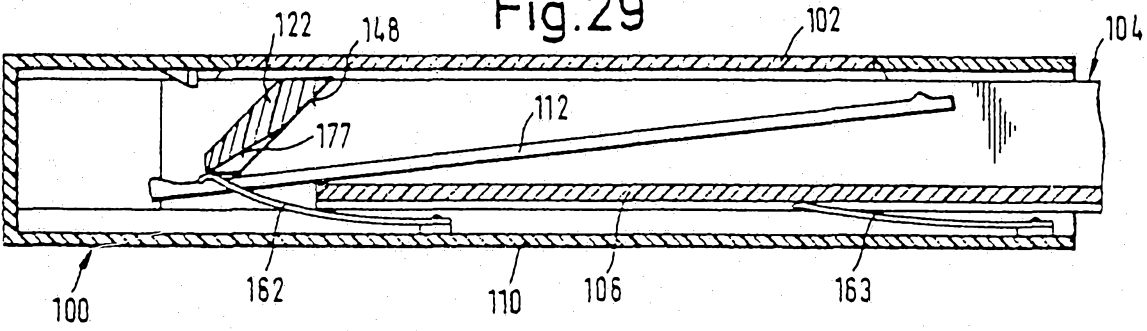
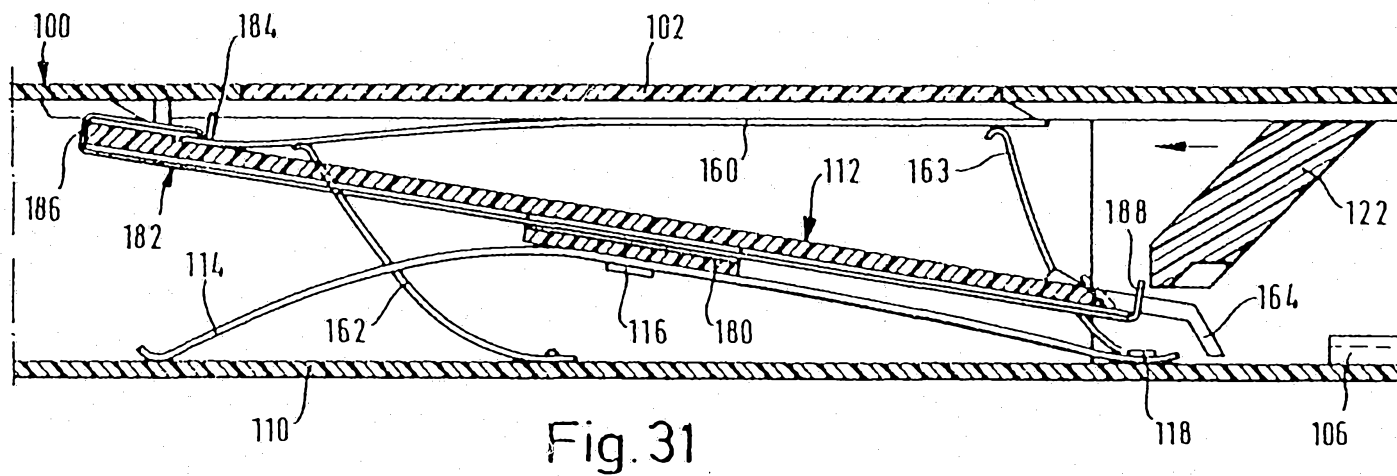
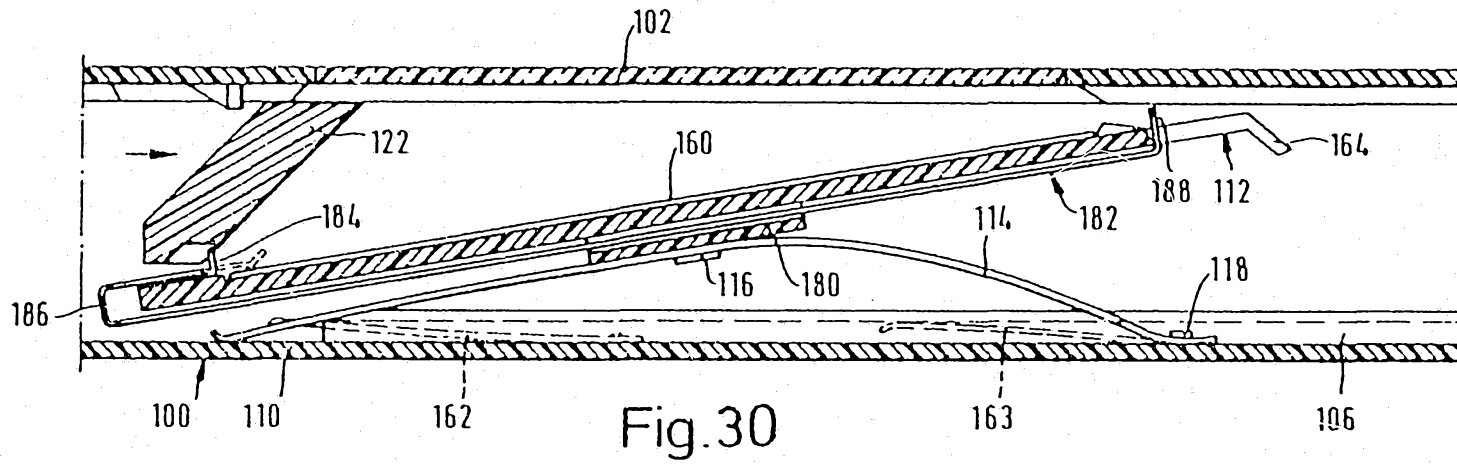

Fig.29





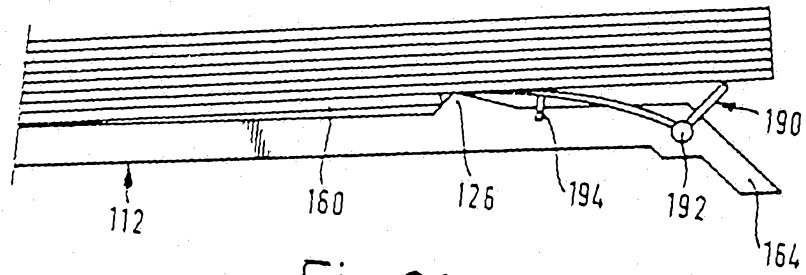
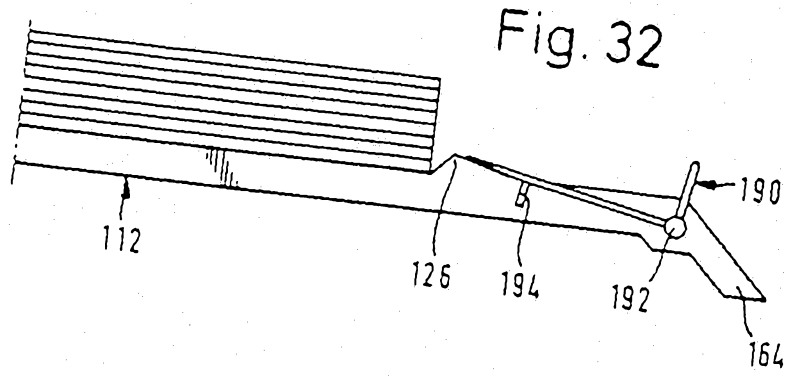

Fig. 33

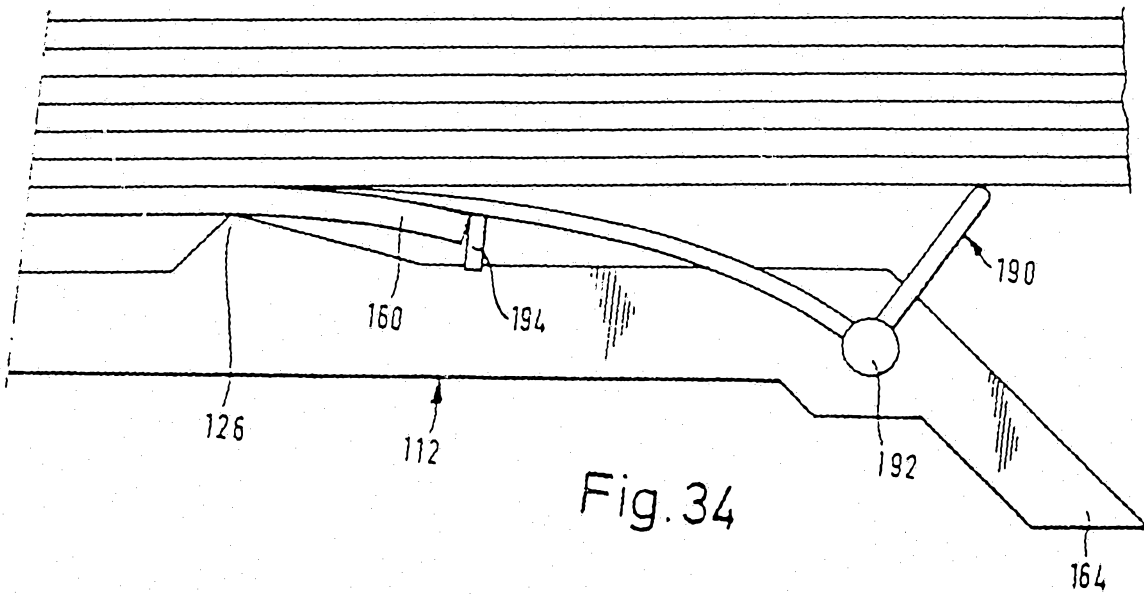

Fig. 34

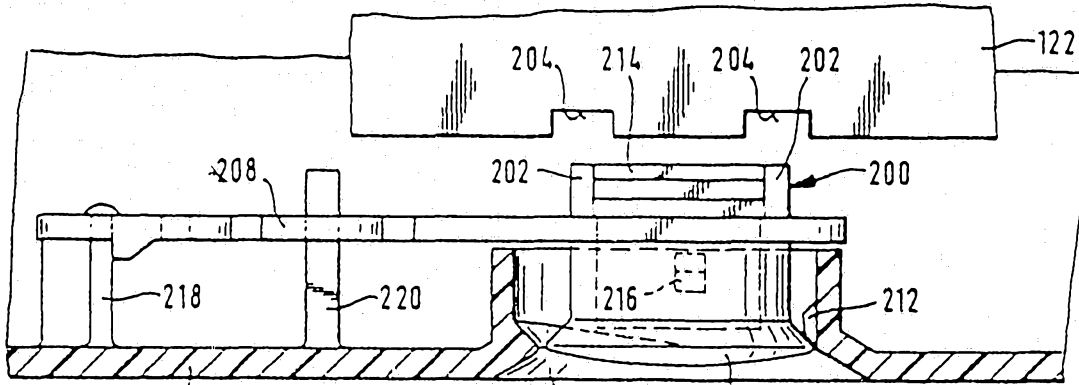

Fig. 35

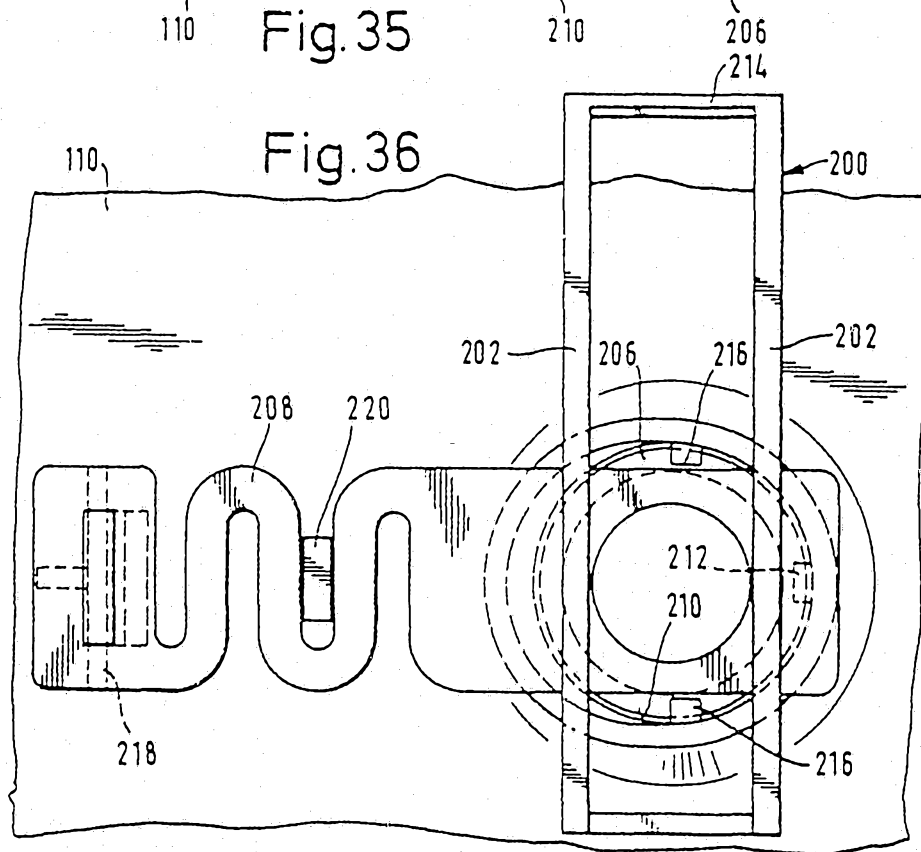

Fig. 36

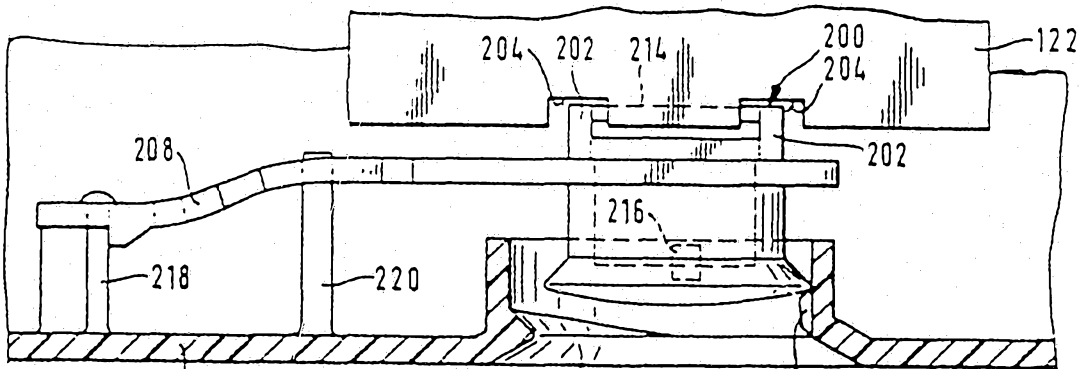

Fig. 37

Fig. 38

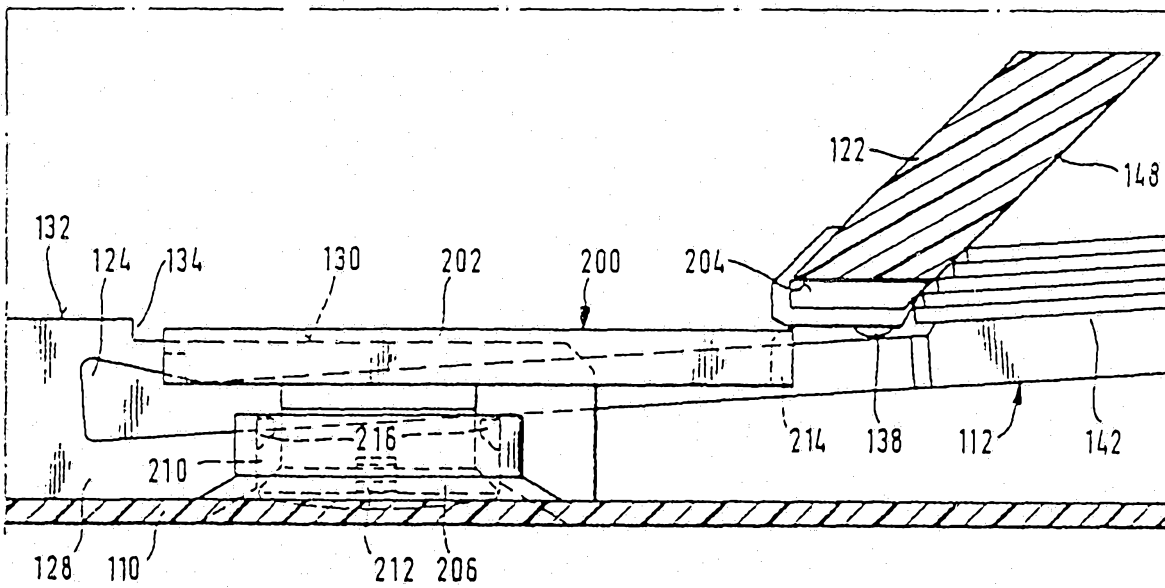
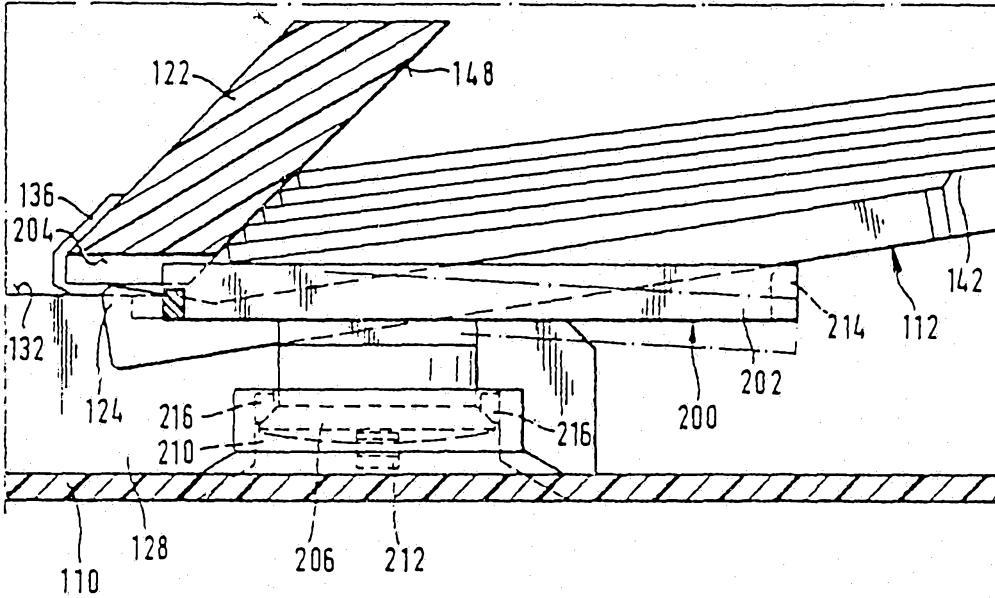
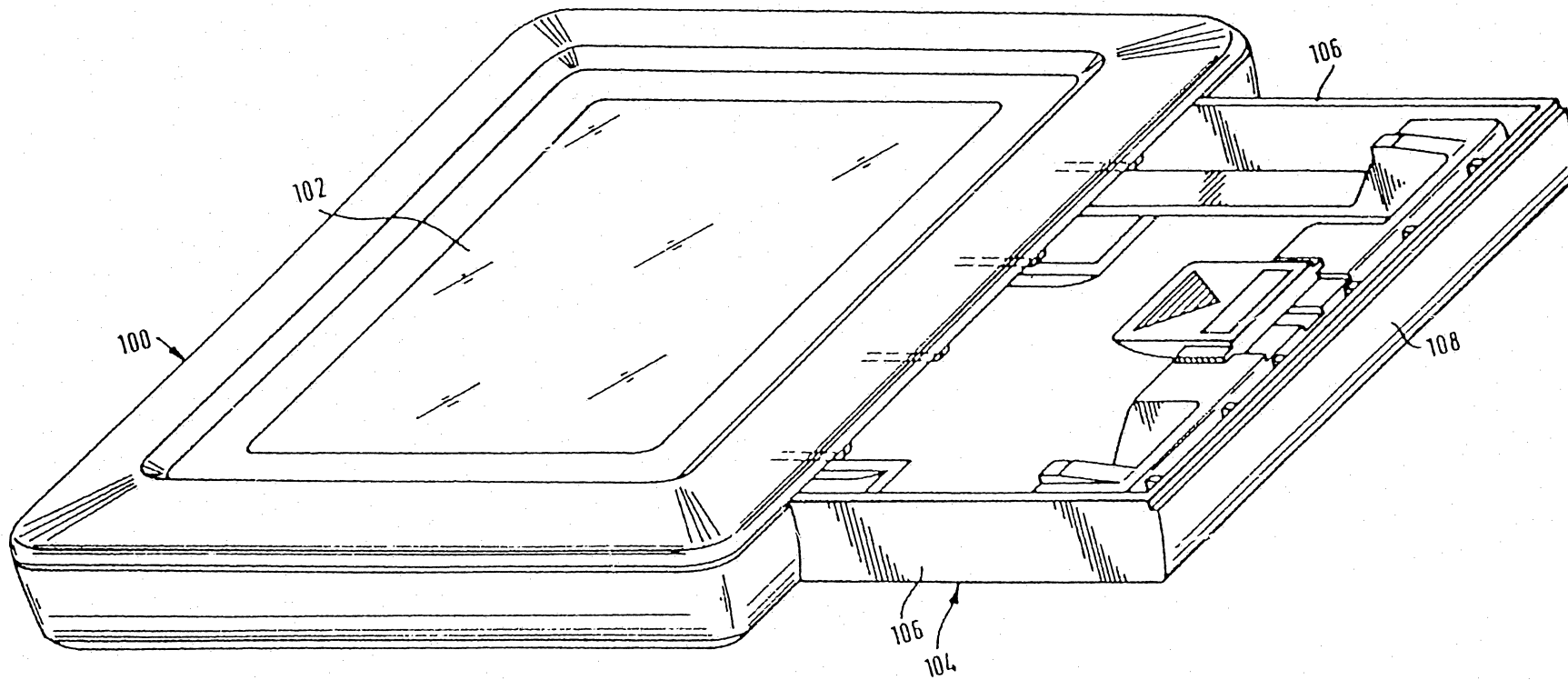

Fig. 39



16/33

Fig. 40

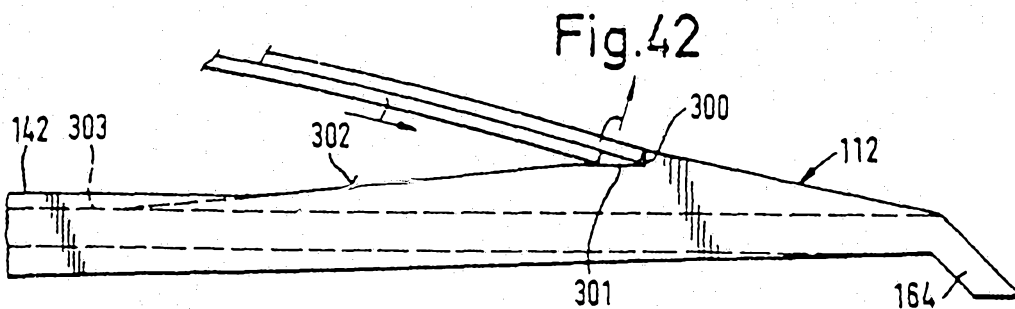
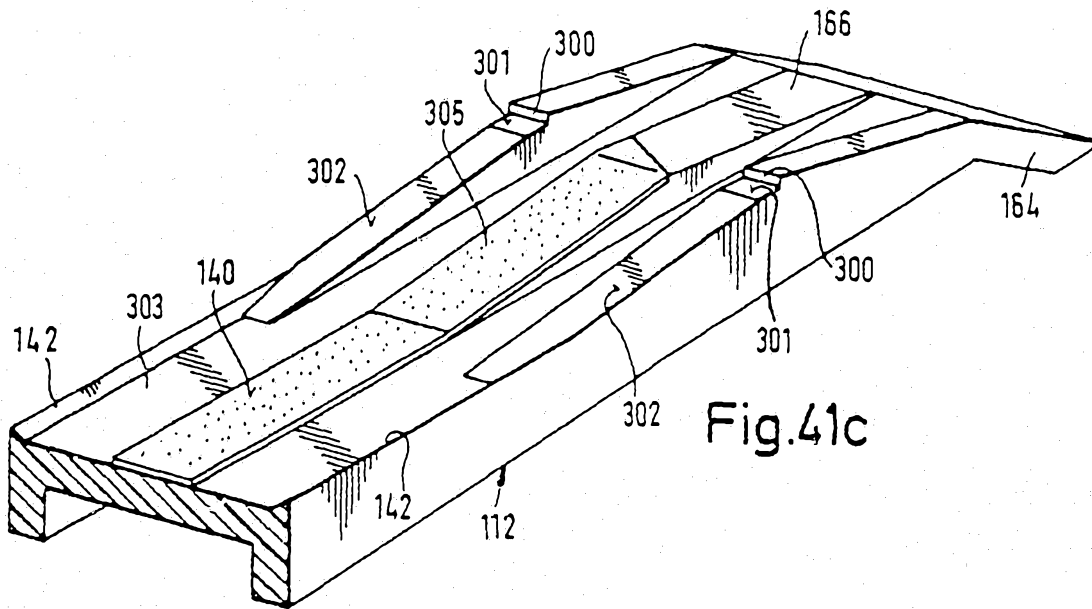
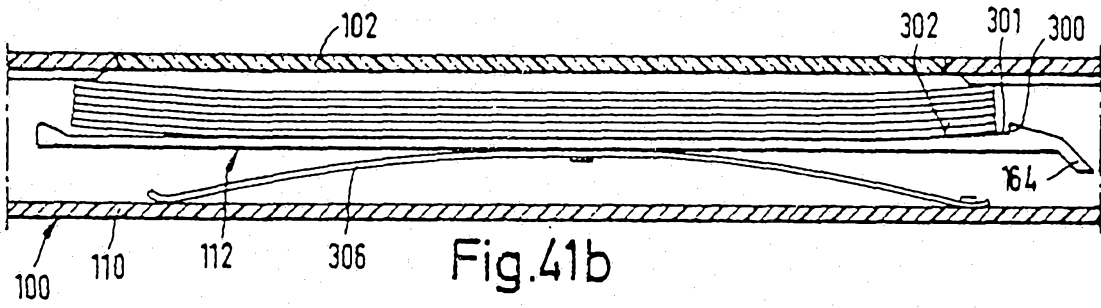
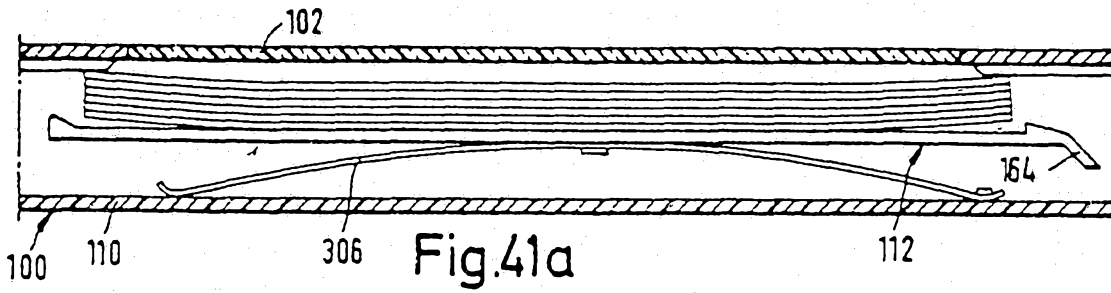

Fig. 43

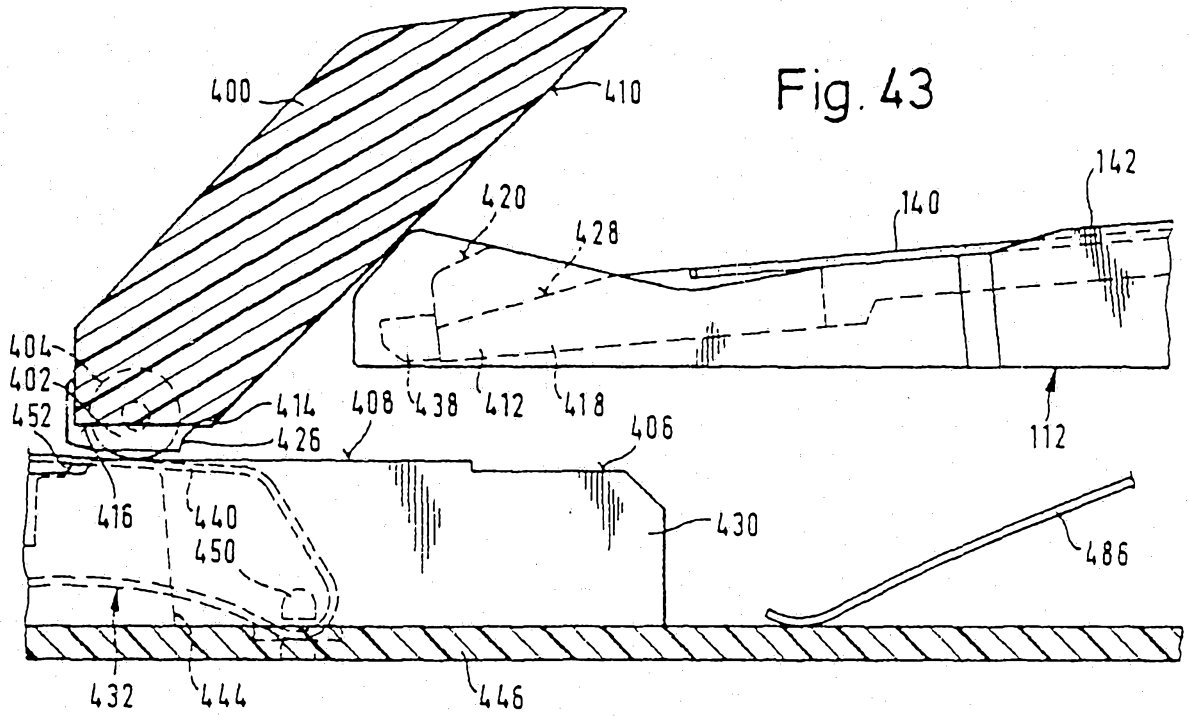
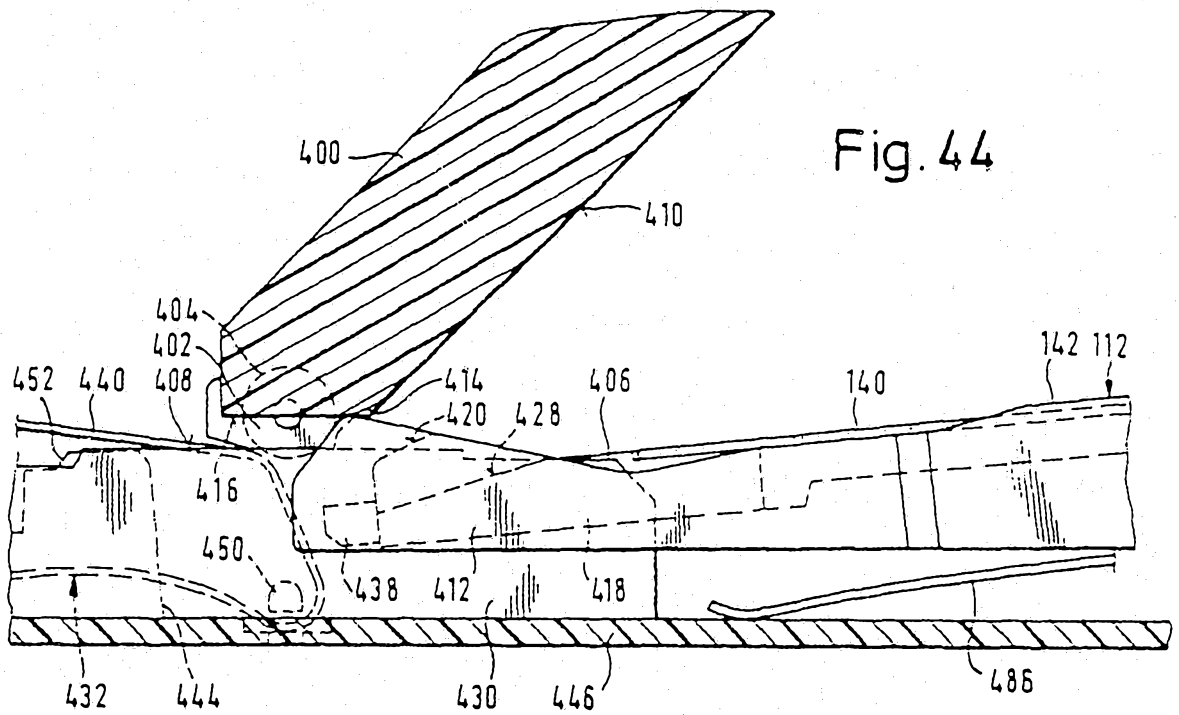

Fig. 44



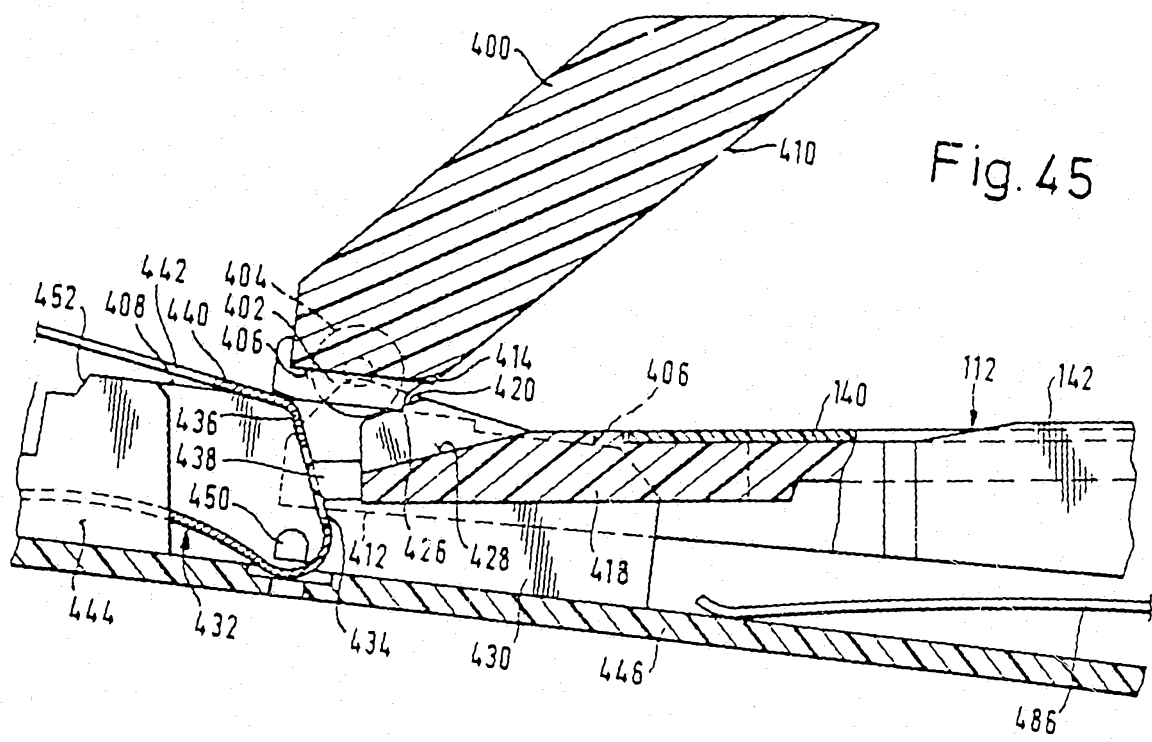

Fig. 45

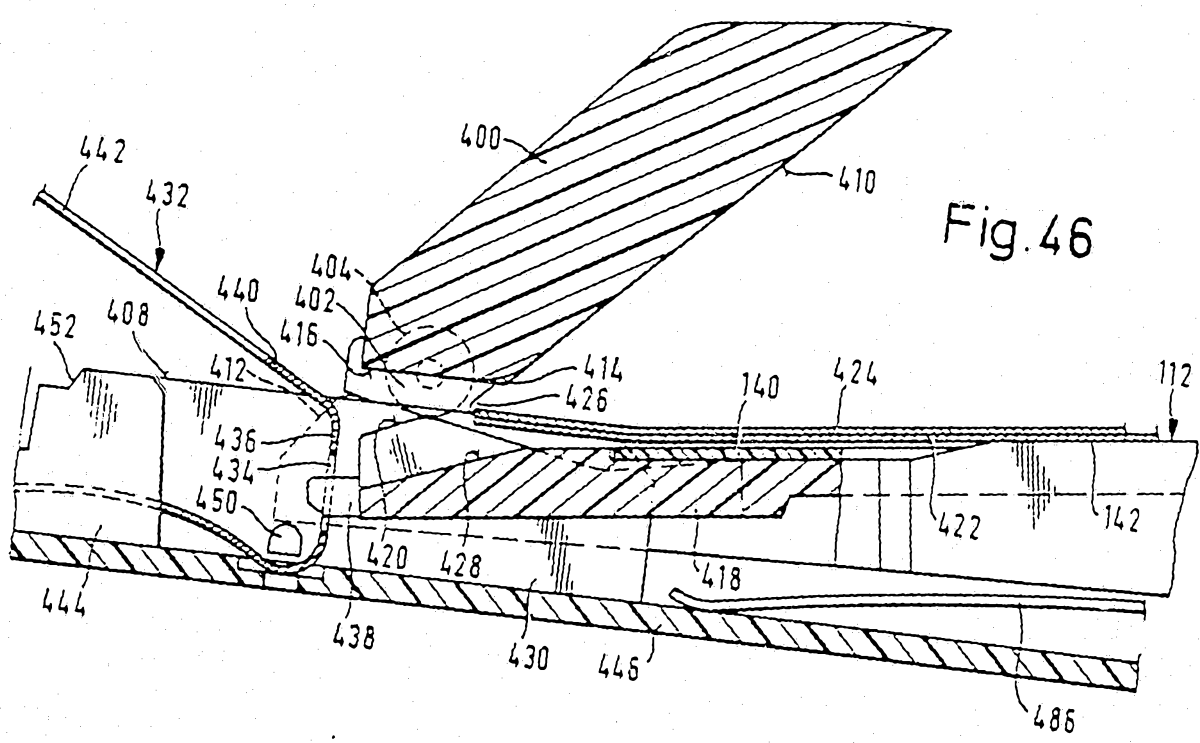

Fig. 46



Fig.48

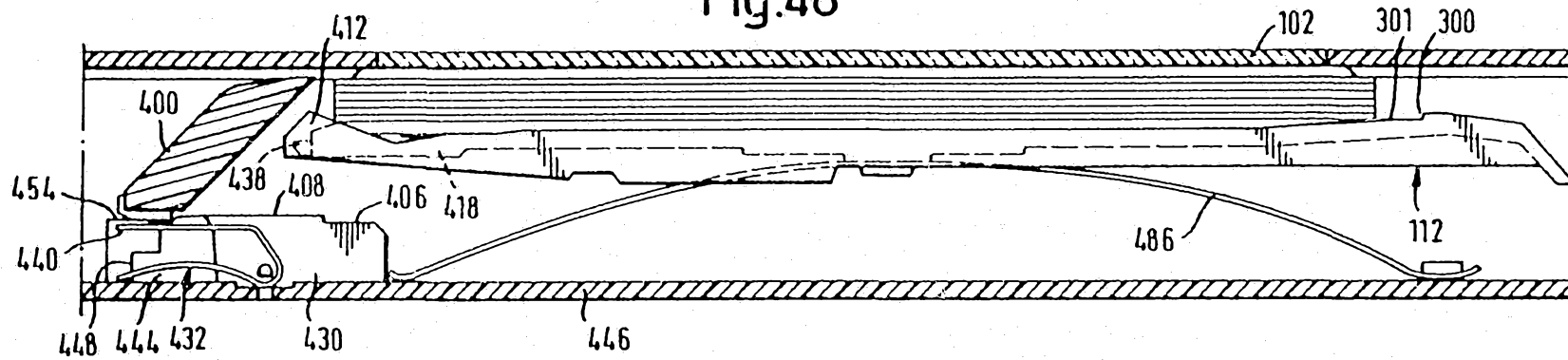
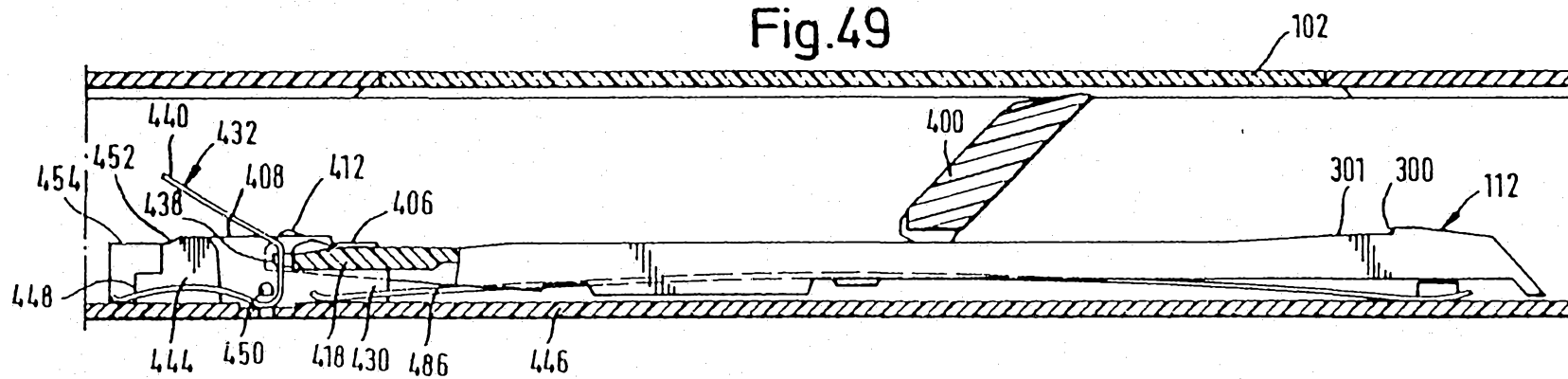

Fig.49



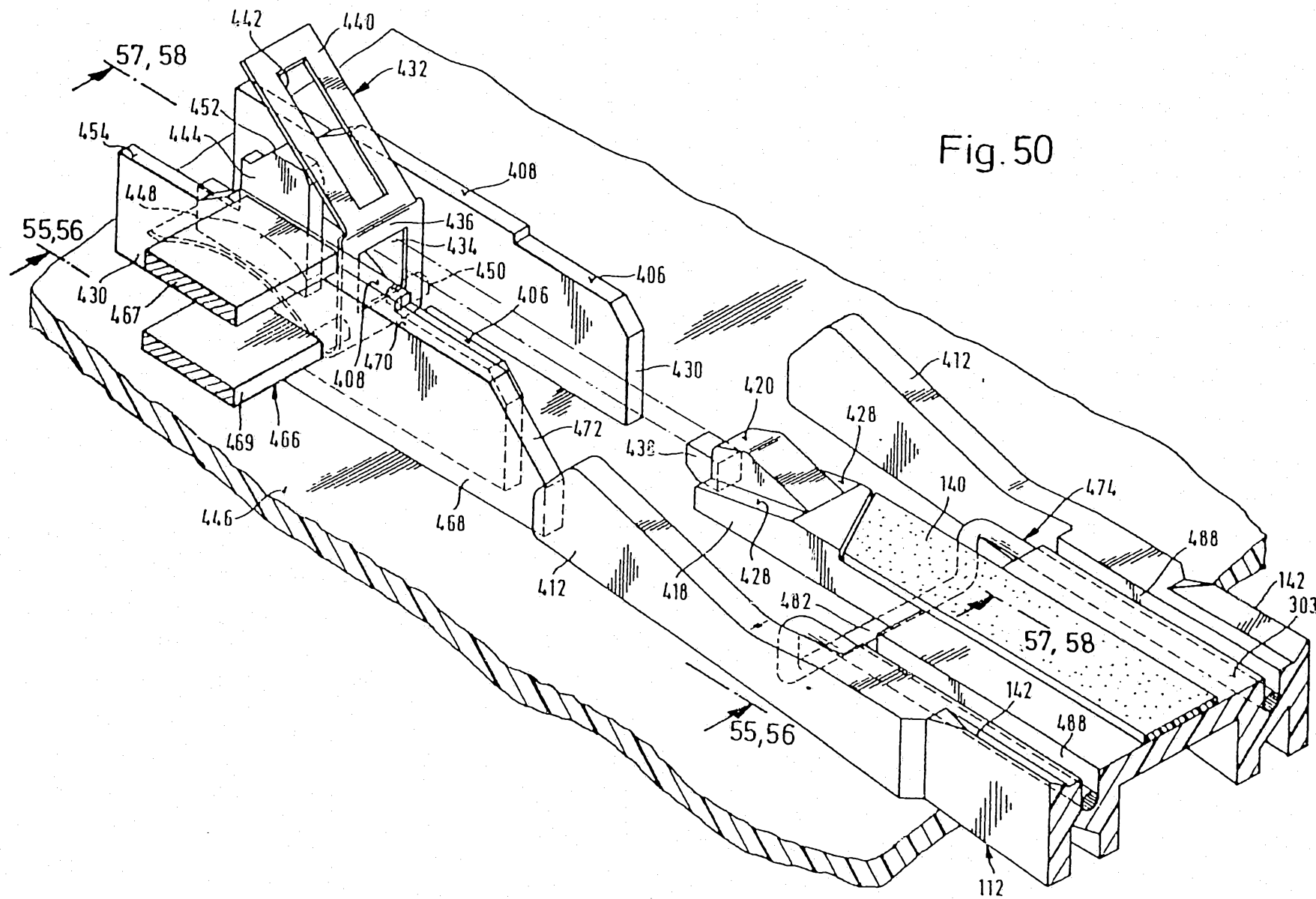

Fig. 50

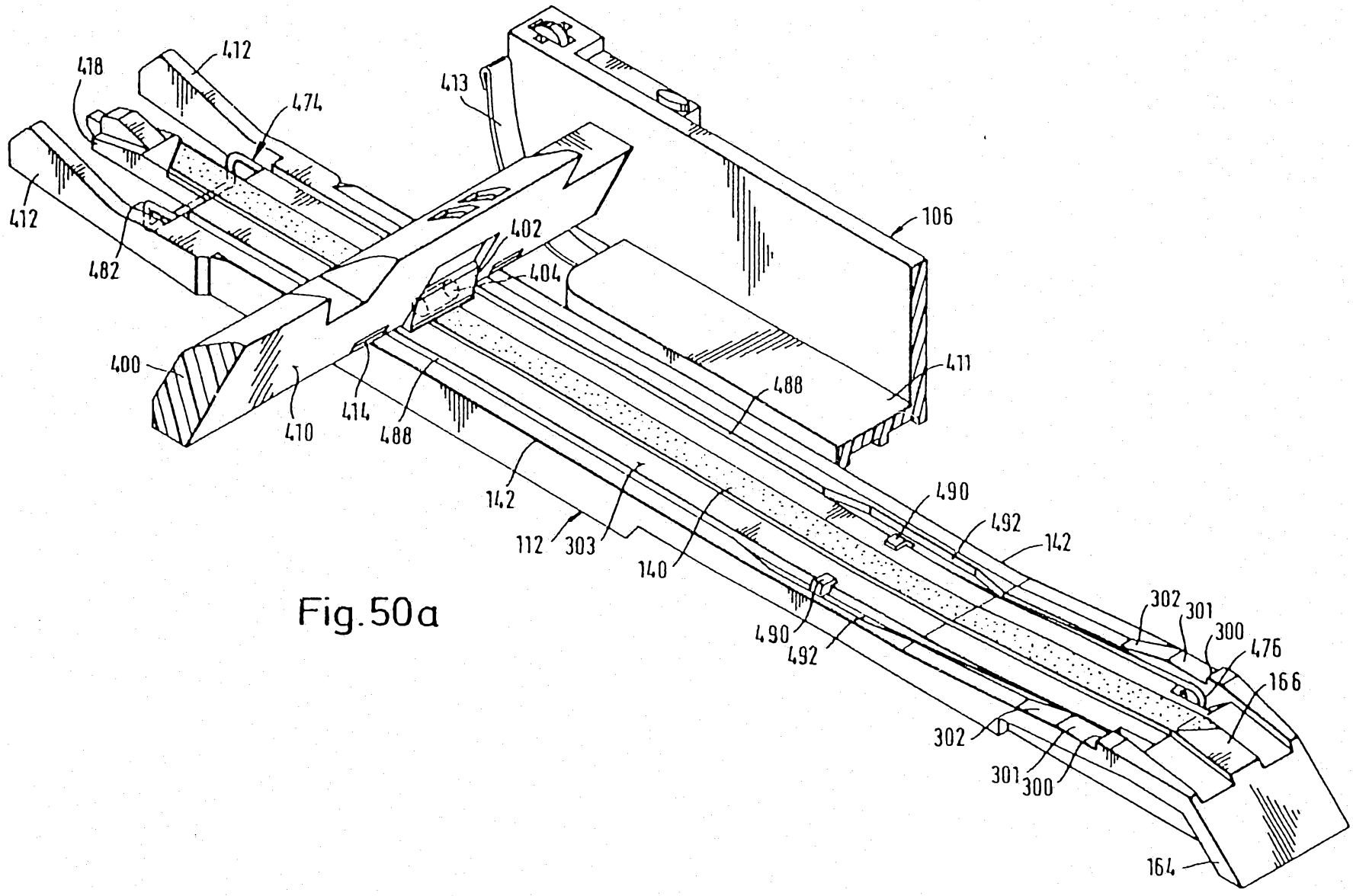

Fig. 50a

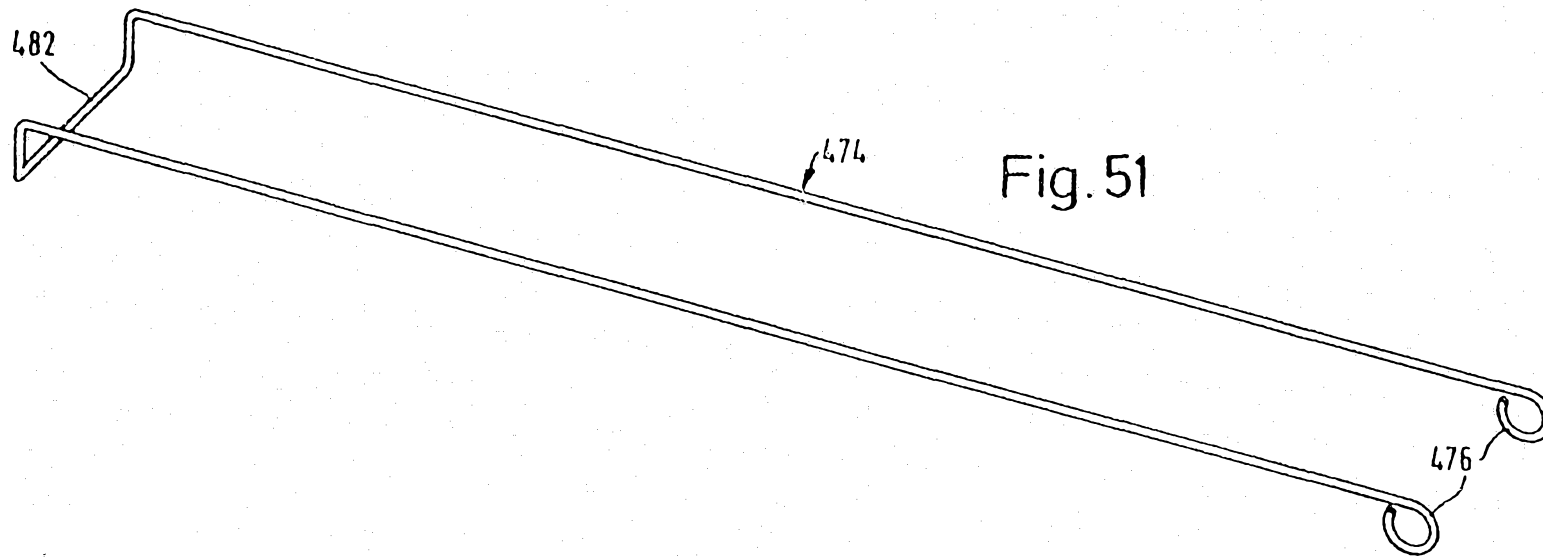
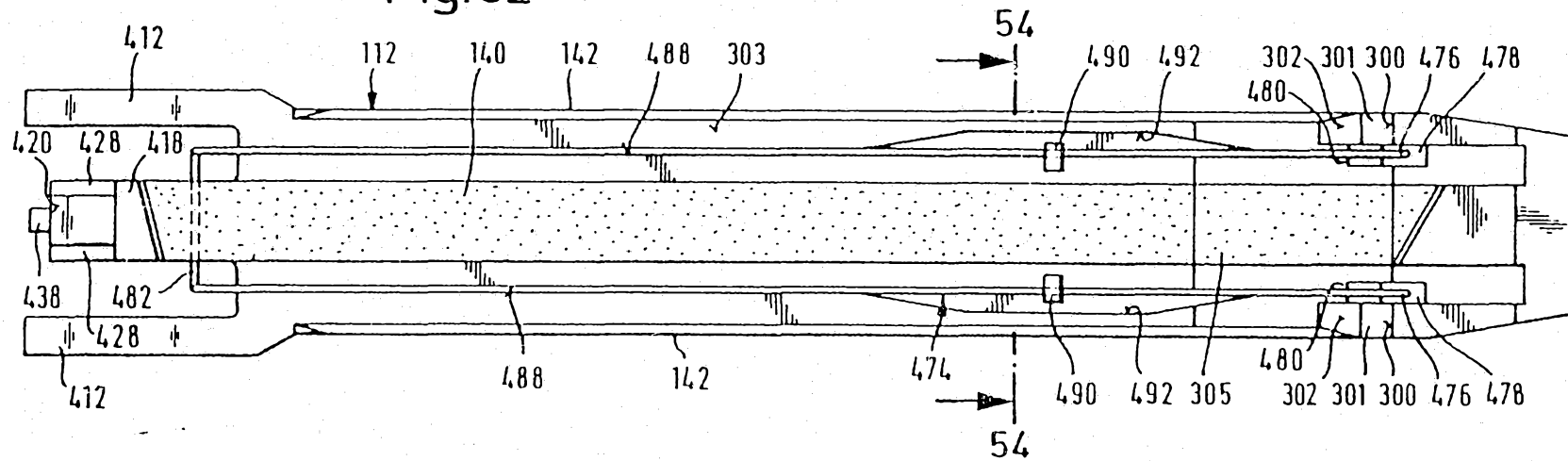

Fig. 52



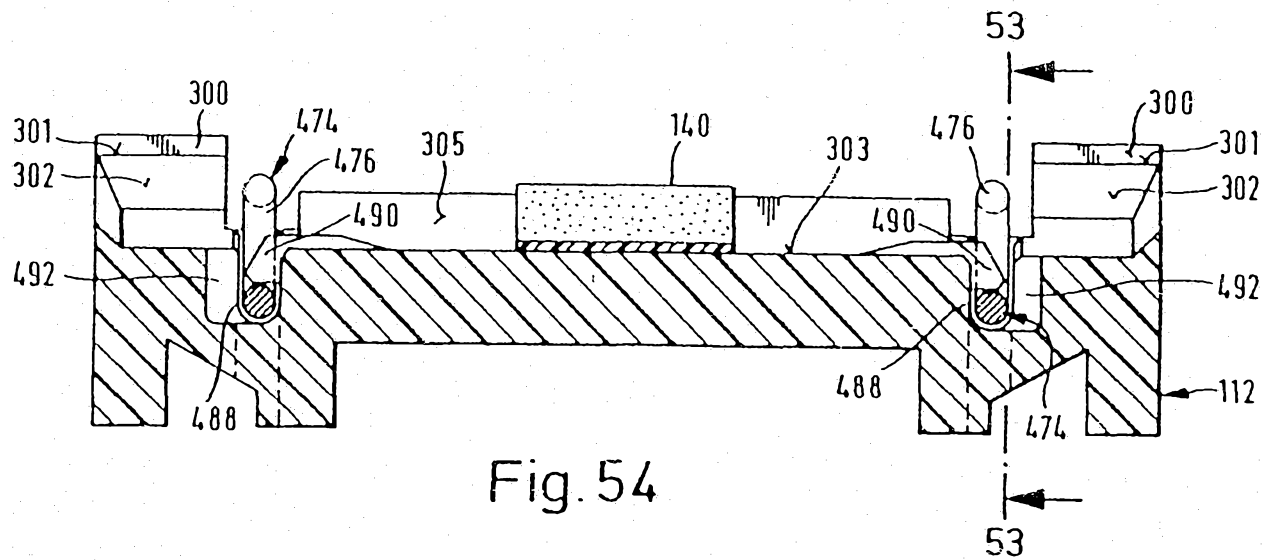
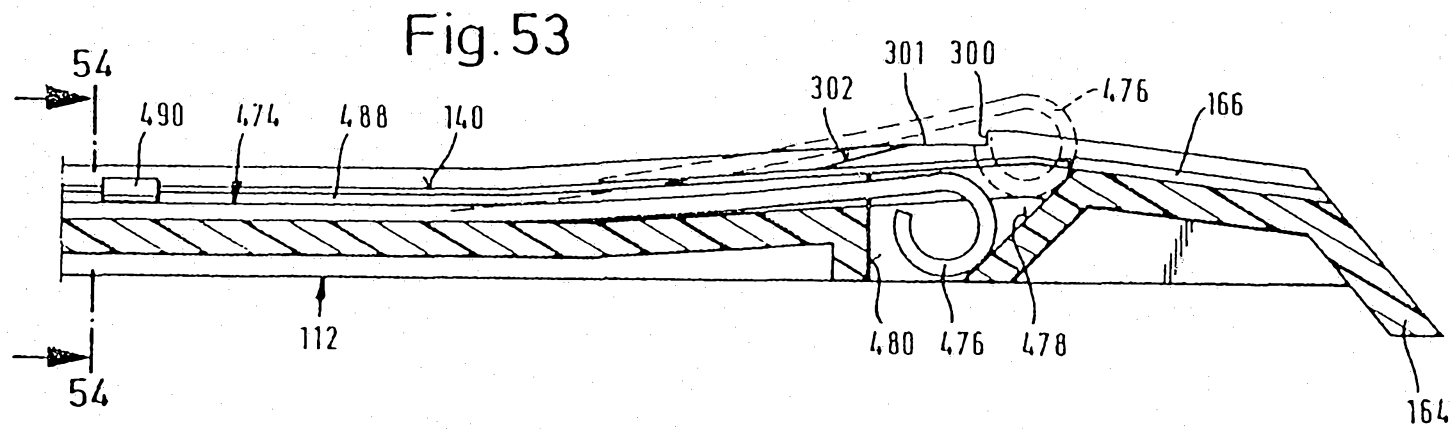

Fig. 55

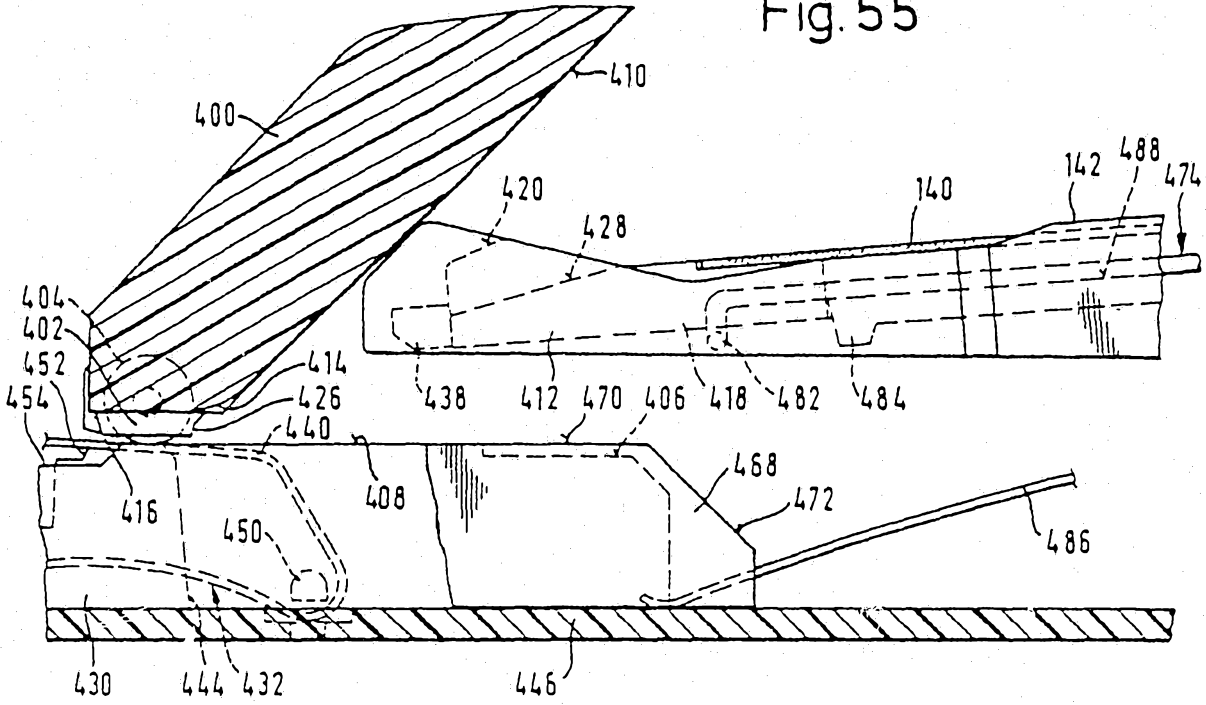
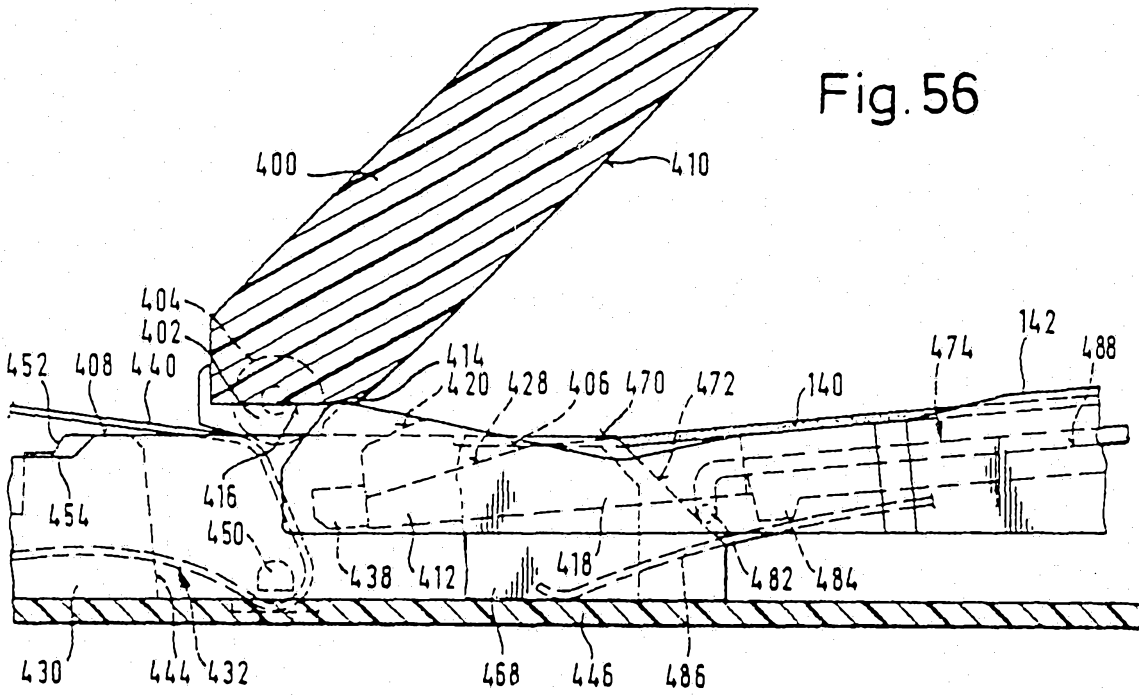

Fig. 56



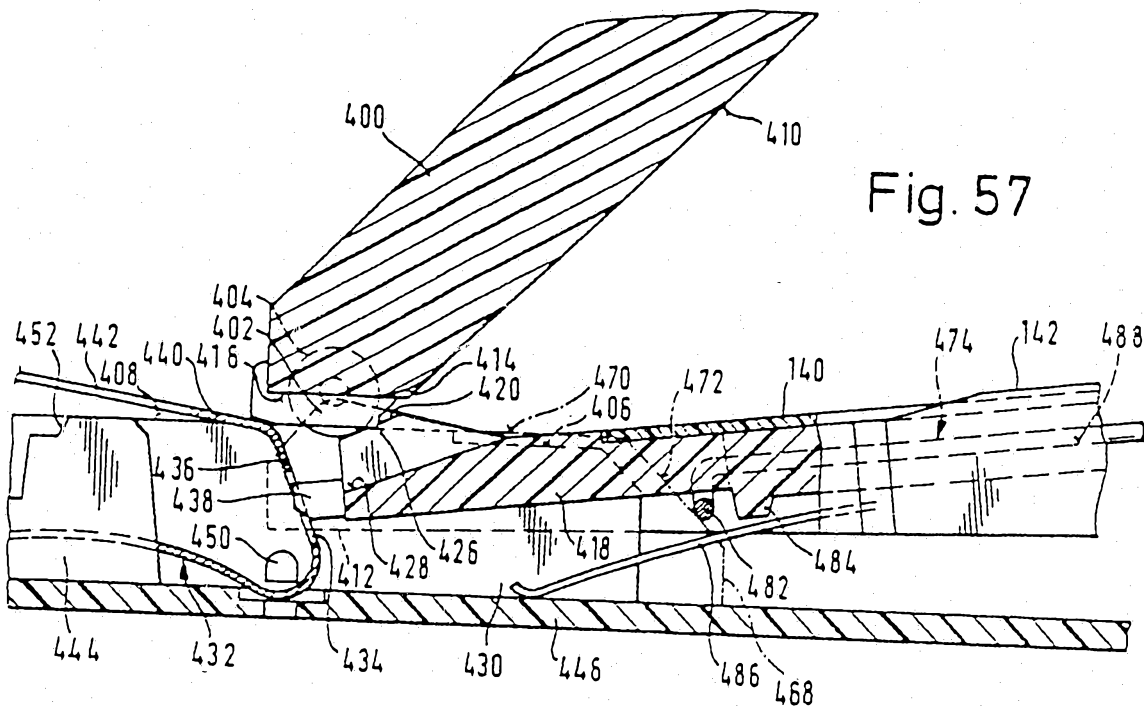

Fig. 57

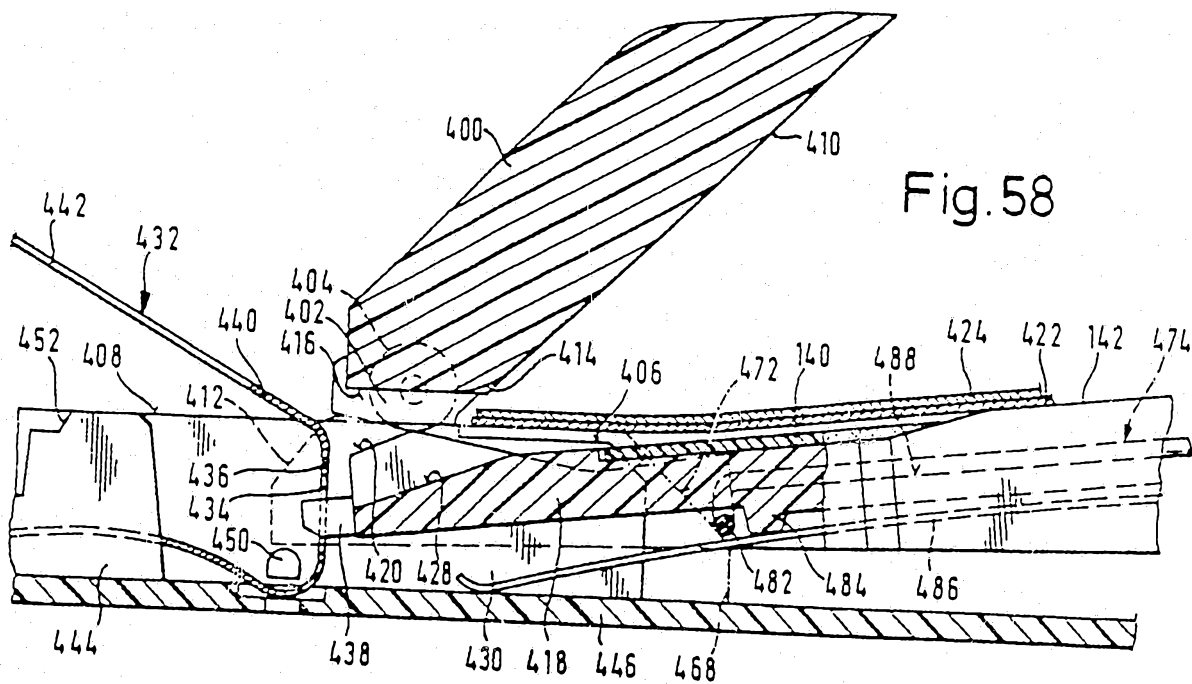
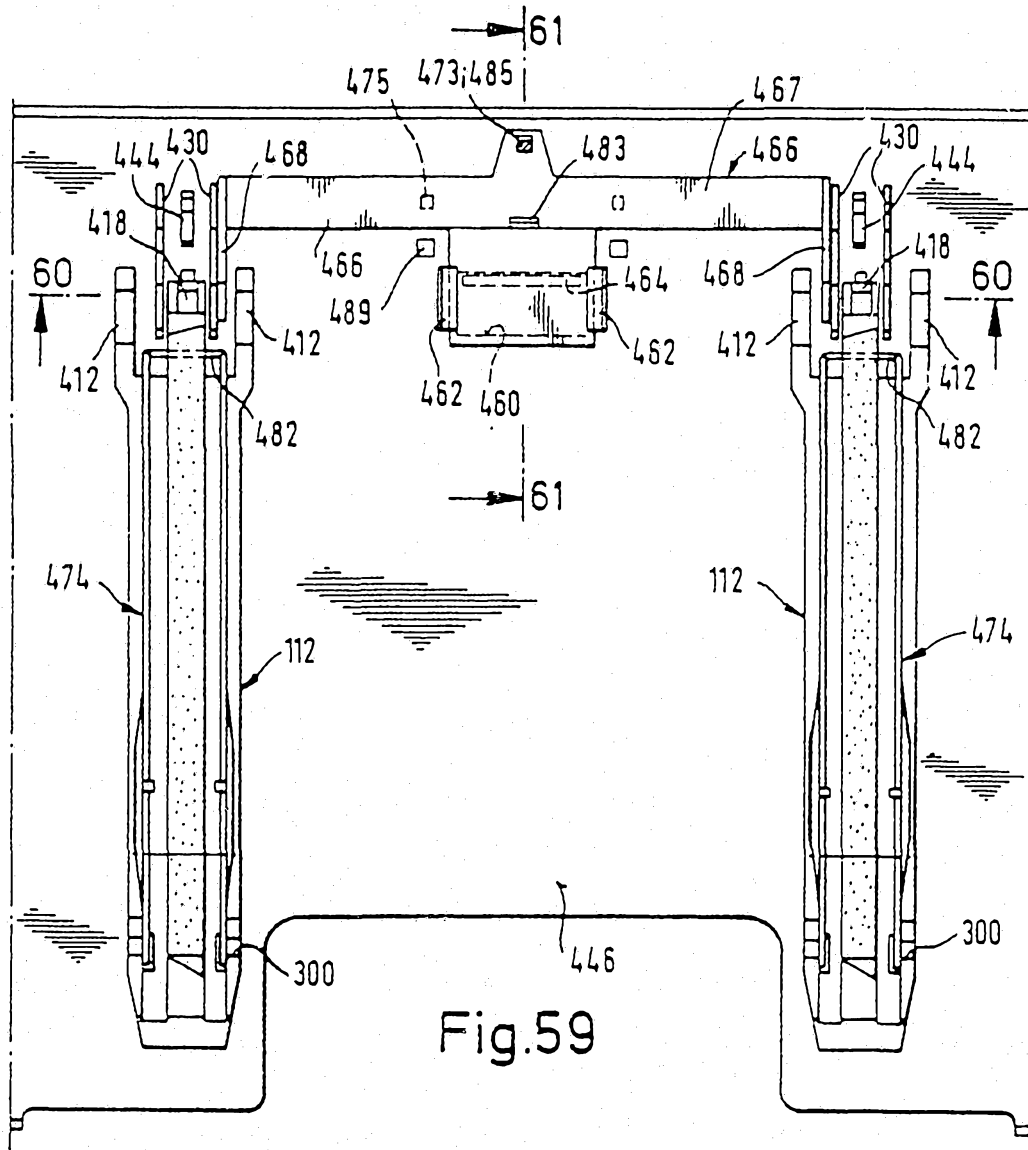

Fig. 58



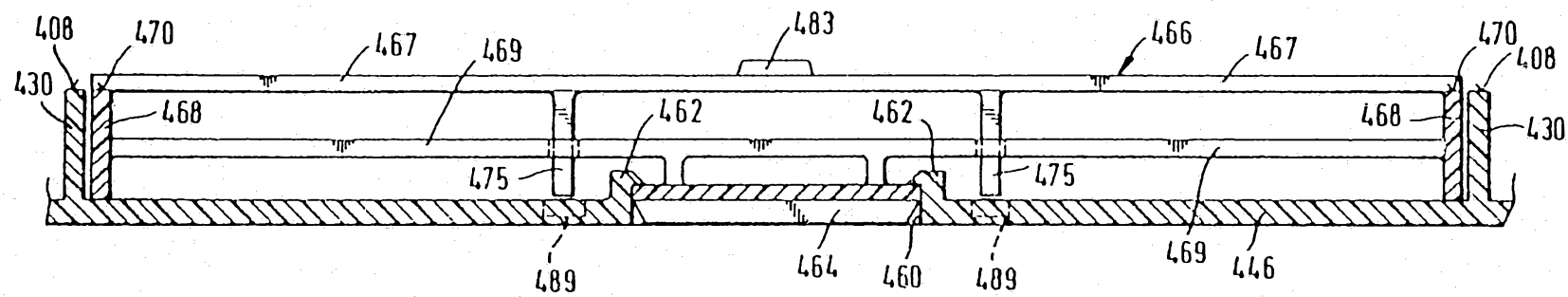

Fig.60

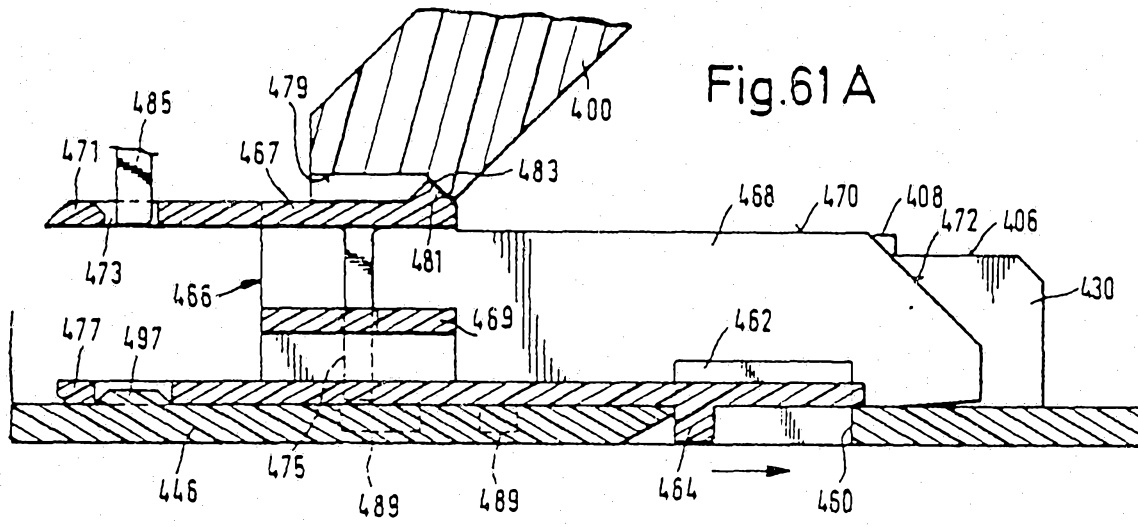

Fig. 61A

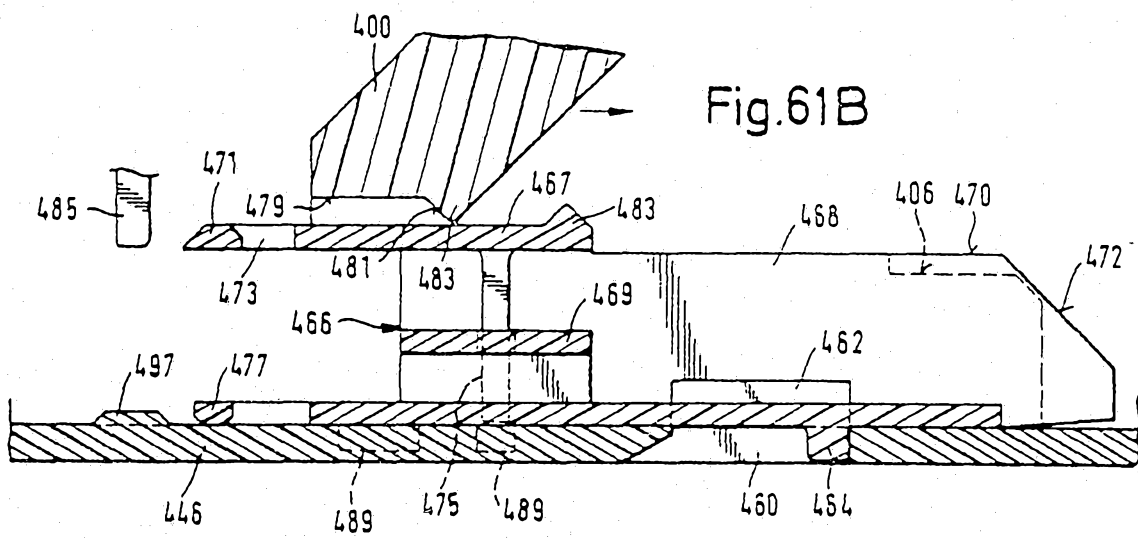

Fig. 61B

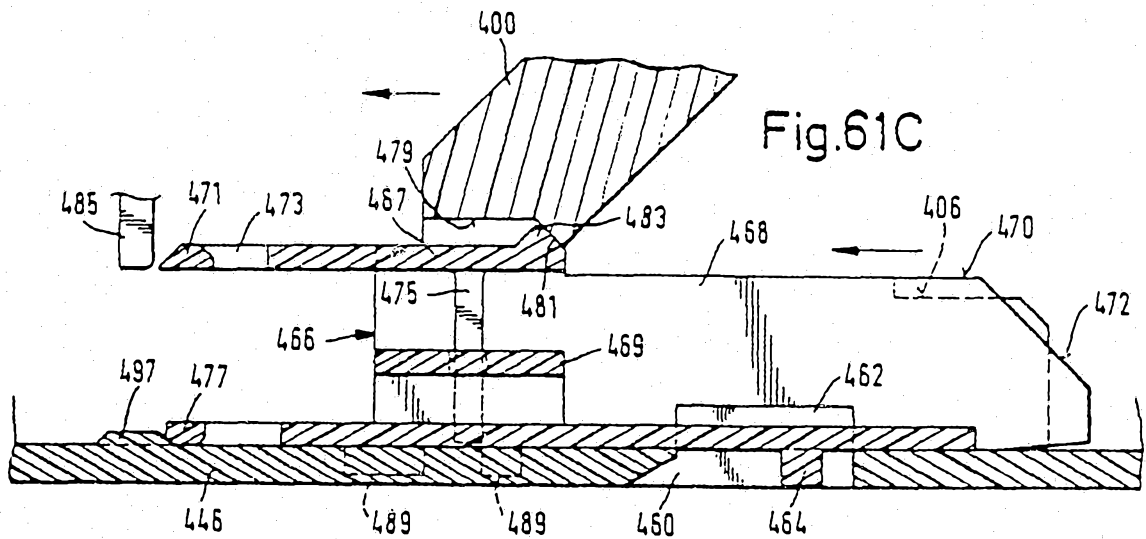

Fig. 61C

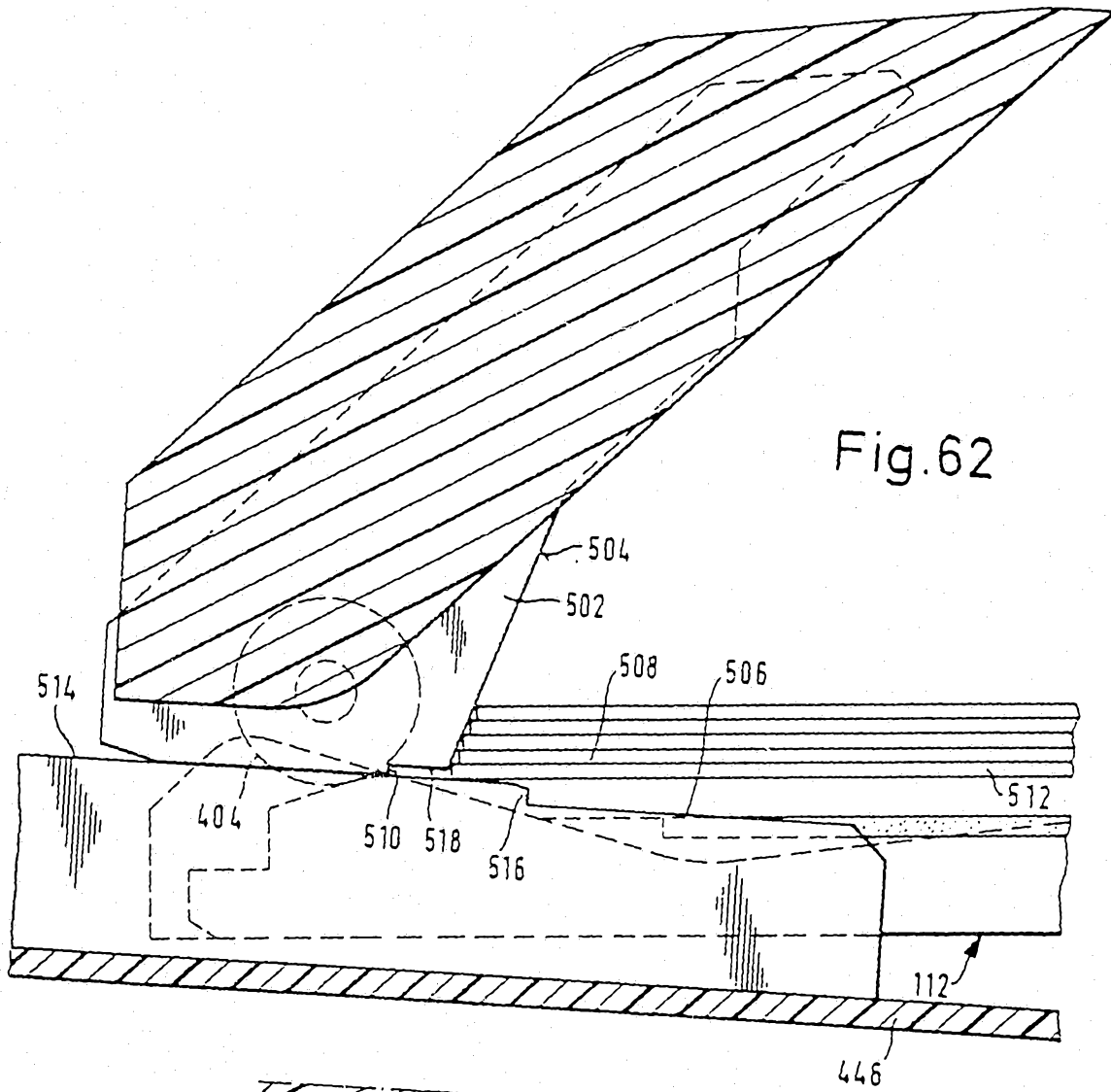

Fig. 62

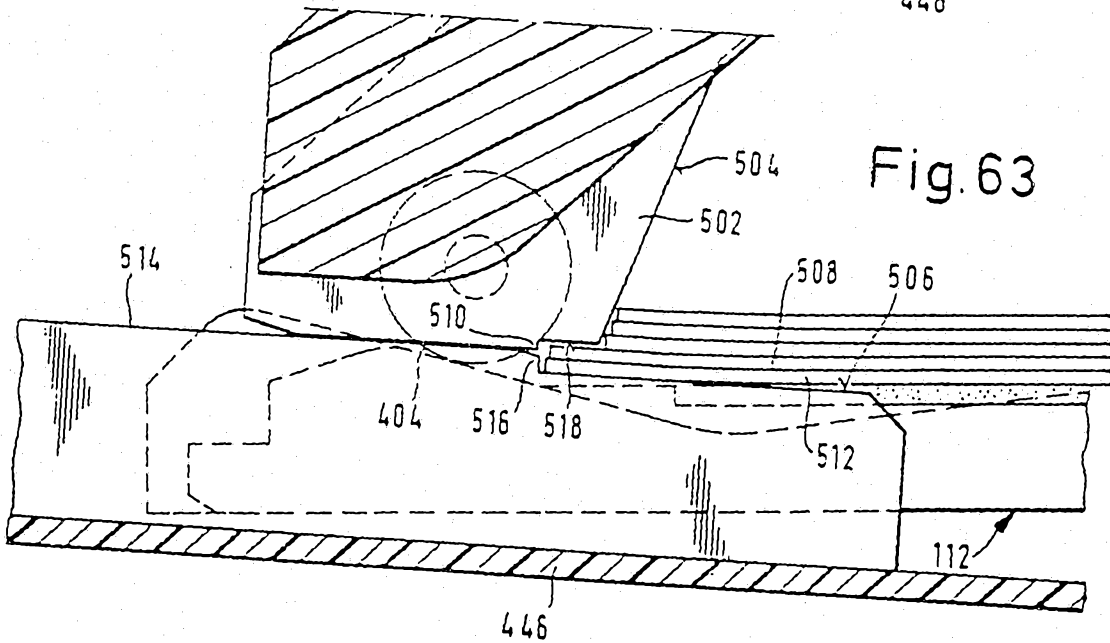

Fig. 63

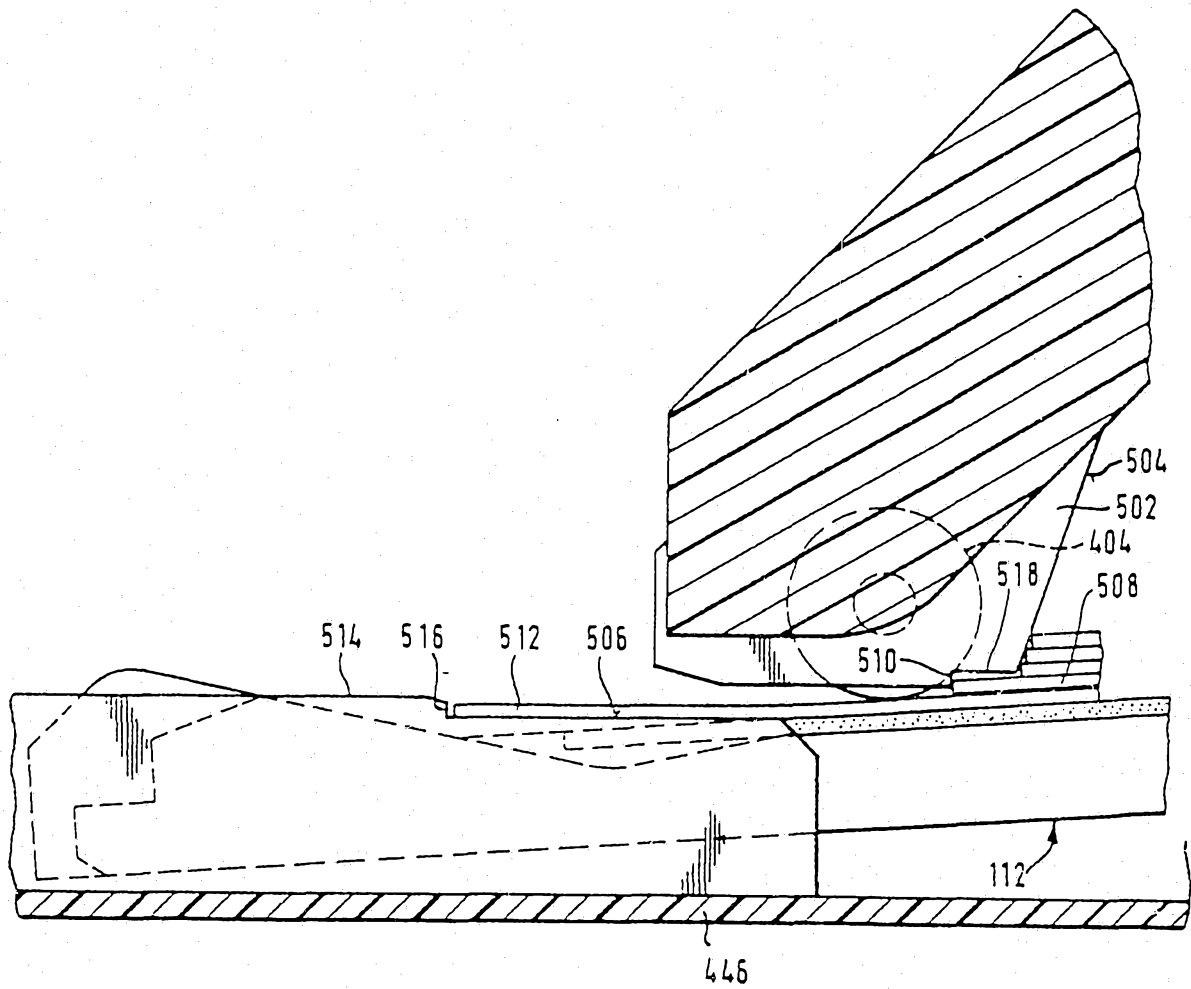
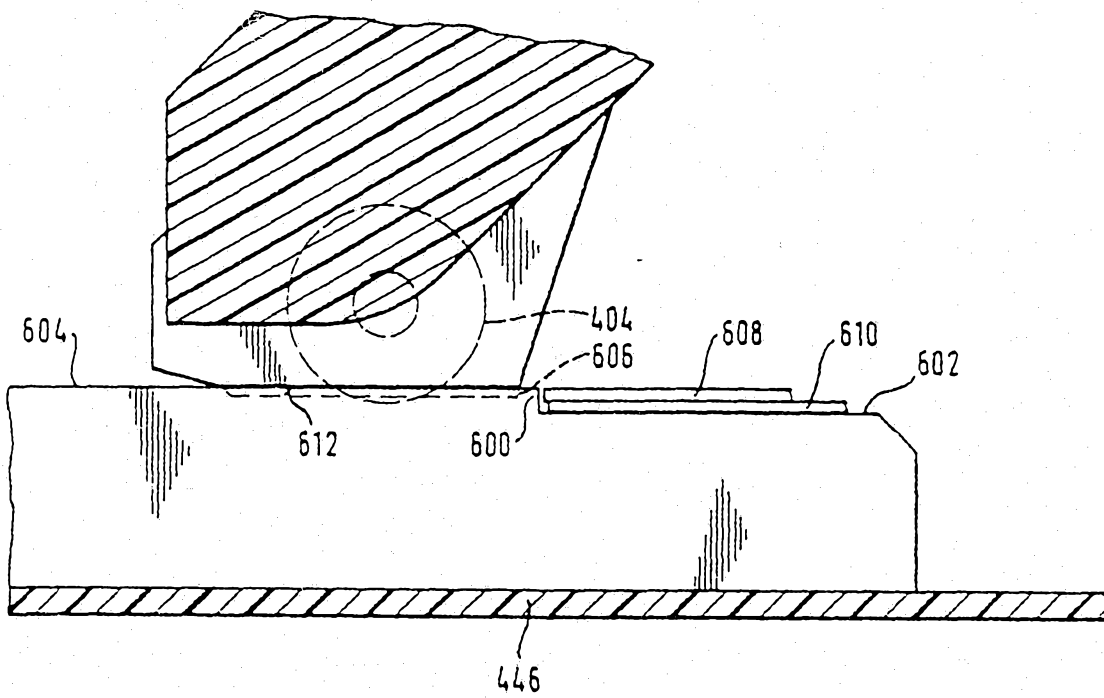
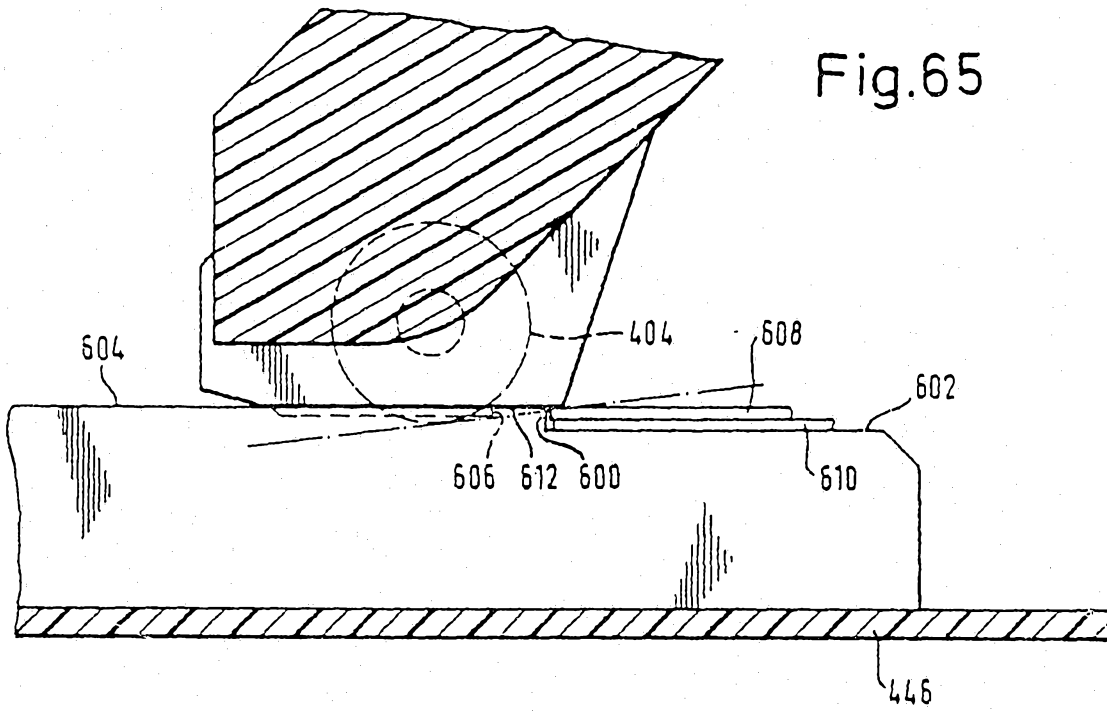

Fig. 64



# INTERNATIONAL SEARCH REPORT

International Application No PCT/EP 88/01053

<b>I. CLASSIFICATION OF SUBJECT MATTER</b> (if several classification symbols apply, indicate all) <sup>6</sup>		
According to International Patent Classification (IPC) or to both National Classification and IPC		
Int. Cl <sup>4</sup> : G 03 B 23/02		
<b>II. FIELDS SEARCHED</b>		
Minimum Documentation Searched <sup>7</sup>		
Classification System	Classification Symbols	
Int. Cl <sup>4</sup> :	G 03 B 23/02; G 02 B 27/02; G 9 F 11/30; B 42 F 7/14	
Documentation Searched other than Minimum Documentation t. the Extent that such Documents are Included in the Fields Searched <sup>8</sup>		
<b>III. DOCUMENTS CONSIDERED TO BE RELEVANT</b> <sup>9</sup>		
Category <sup>9</sup>	Citation of Document, <sup>11</sup> with indication, where appropriate, of the relevant passages <sup>12</sup>	Relevant to Claim No. <sup>13</sup>
X	FR, A, 2403574 (LICINVEST AG) 13 April 1979 see pages 6-23; figures 1-52	1, 40-42, 130-133, 135, 136 141-144, 153, 154
X	FR, A, 2454112 (LICINVEST AG) 7 November 1980 see pages 9-42; figures 1-84	2-5, 10, 40- 42, 131, 132- 138, 142-145, 153, 154
A	WO, A, 86/03029 (LICINVEST AG) 22 May 1986 cited in the application see pages 5-55; figures 1-144	67-73, 77- 79, 83, 153- 156, 159- 169, 171, 172
-----		
<p><sup>9</sup> Special categories of cited documents: <sup>10</sup></p> <p>"A" document defining the general state of the art which is not considered to be of particular relevance</p> <p>"E" earlier document but published on or after the international filing date</p> <p>"L" document which may throw doubts on priority claim(s) or which is cited to establish the publication date of another citation or other special reason (as specified)</p> <p>"O" document referring to an oral disclosure, use, exhibition or other means</p> <p>"P" document published prior to the international filing date but later than the priority date claimed</p> <p>"T" later document published after the international filing date or priority date and not in conflict with the application but cited to understand the principle or theory underlying the invention</p> <p>"X" document of particular relevance; the claimed invention cannot be considered novel or cannot be considered to involve an inventive step</p> <p>"Y" document of particular relevance; the claimed invention cannot be considered to involve an inventive step when the document is combined with one or more other such documents, such combination being obvious to a person skilled in the art.</p> <p>"&amp;" document member of the same patent family</p>		
<b>IV. CERTIFICATION</b> <sup>14</sup>		
Date of the Actual Completion of the International Search	Date of Mailing of this International Search Report	
24 February 1989 (24.02.89)	15 March 1989 (15.03.89)	
International Searching Authority	Signature of Authorized Officer	
European Patent Office		

ANNEX TO THE INTERNATIONAL SEARCH REPORT  
ON INTERNATIONAL PATENT APPLICATION NO.

EP 8801053  
SA 25384

This annex lists the patent family members relating to the patent documents cited in the above-mentioned international search report. The members are as contained in the European Patent Office EDP file on 07/03/89. The European Patent Office is in no way liable for these particulars which are merely given for the purpose of information.

Patent document cited in search report	Publication date	Patent family member(s)	Publication date		
FR-A- 2403574	13-04-79	BE-A- 870625	20-03-79		
		GB-A, B 2005227	19-04-79		
		NL-A- 7809574	22-03-79		
		DE-A, B, C 2742349	29-03-79		
		JP-A- 54056829	08-05-79		
		AU-A- 3961178	13-03-80		
		US-A- 4245417	20-01-81		
		CA-A- 1106662	11-08-81		
		AU-B- 517556	06-08-81		
		CH-A- 633483	15-12-82		
		SE-A- 7809730	21-03-79		
		SE-B- 430870	19-12-83		
		NL-A- 8600657	01-07-86		
		NL-A- 8600658	01-07-86		
		NL-A- 8600659	01-07-86		
		AT-B- 385133	25-02-88		
		AT-B- 386289	25-07-88		
		AT-B- 386290	25-07-88		
		US-E- 32766	18-10-88		
		DE-A, C 2752195	07-06-79		
		FR-A, B 2415011	17-08-79		
		DE-A- 2802459	26-07-79		
		GB-A, B 2017048	26-09-79		
		JP-A- 54123321	25-09-79		
		US-A- 4266834	12-05-81		
		FR-A- 2454112	07-11-80	BE-A- 882696	31-07-80
				NL-A- 8001995	13-10-80
				DE-A- 2914351	30-10-80
				GB-A, B 2049627	31-12-80
AU-A- 5720480	16-10-80				
JP-A- 56008016	27-01-81				
FR-A, B 2476329	21-08-81				
GB-A, B 2073147	14-10-81				
US-A- 4376348	15-03-83				
CA-A- 1143970	05-04-83				
SE-A- 8002637	10-10-80				
CH-A- 643665	15-06-84				
US-A- 4458434	10-07-84				