



INTERNATIONAL APPLICATION PUBLISHED UNDER THE PATENT COOPERATION TREATY (PCT)

(51) International Patent Classification ⁷ : A61F 2/00	A2	(11) International Publication Number: WO 00/62707 (43) International Publication Date: 26 October 2000 (26.10.00)
(21) International Application Number: PCT/GB00/01349 (22) International Filing Date: 10 April 2000 (10.04.00) (30) Priority Data: 9908638.1 15 April 1999 (15.04.99) GB (71) Applicant (for all designated States except US): UNIVERSITY COLLEGE LONDON [GB/GB]; Gower Street, London WC1 6BT (GB). (72) Inventors; and (75) Inventors/Applicants (for US only): BLUNN, Gordon [GB/GB]; 24 North End, Bassingbourn, Royston, North Hertfordshire SG8 5NY (GB). BARRETT, David [GB/GB]; Southampton General Hospital, Orthopaedic Department, F Level, Tremona Road, Southampton SO16 6YD (GB). MUIRHEAD-ALLWOOD, Sarah [GB/GB]; 19 Wimpole Street, London W1M 7AD (GB). (74) Agent: WOODCRAFT, David, Charles; Brookes & Martin, High Holborn House, 52/54 High Holborn, London WC1V 6SE (GB).		(81) Designated States: AE, AL, AM, AT, AU, AZ, BA, BB, BG, BR, BY, CA, CH, CN, CR, CU, CZ, DE, DK, DM, EE, ES, FI, GB, GD, GE, GH, GM, HR, HU, ID, IL, IN, IS, JP, KE, KG, KP, KR, KZ, LC, LK, LR, LS, LT, LU, LV, MA, MD, MG, MK, MN, MW, MX, NO, NZ, PL, PT, RO, RU, SD, SE, SG, SI, SK, SL, TJ, TM, TR, TT, TZ, UA, UG, US, UZ, VN, YU, ZA, ZW, ARIPO patent (GH, GM, KE, LS, MW, SD, SL, SZ, TZ, UG, ZW), Eurasian patent (AM, AZ, BY, KG, KZ, MD, RU, TJ, TM), European patent (AT, BE, CH, CY, DE, DK, ES, FI, FR, GB, GR, IE, IT, LU, MC, NL, PT, SE), OAPI patent (BF, BJ, CF, CG, CI, CM, GA, GN, GW, ML, MR, NE, SN, TD, TG). Published <i>Without international search report and to be republished upon receipt of that report.</i>
(54) Title: USE OF OSSEO-PROMOTIVE MEMBRANES IN ORTHOPAEDICS		
(57) Abstract <p>The use of an occlusive or semi-occlusive membrane is described for promotion of bone growth in orthopaedic surgery, wherein a bone injury is sealed by closing the injury with a membrane which is substantially inert to body fluids and is adapted to prevent ingrowth of fibrous tissue into said injury. Preferably, the membrane is a laminate of at least two layers comprising a first layer having openings of a size which are adapted to be penetrated by fibrous soft tissue, and a second layer which is non-porous or has pores which are too small to be penetrated by soft tissue, the second layer being adapted to lie adjacent the bone injury.</p>		

FOR THE PURPOSES OF INFORMATION ONLY

Codes used to identify States party to the PCT on the front pages of pamphlets publishing international applications under the PCT.

AL	Albania	ES	Spain	LS	Lesotho	SI	Slovenia
AM	Armenia	FI	Finland	LT	Lithuania	SK	Slovakia
AT	Austria	FR	France	LU	Luxembourg	SN	Senegal
AU	Australia	GA	Gabon	LV	Latvia	SZ	Swaziland
AZ	Azerbaijan	GB	United Kingdom	MC	Monaco	TD	Chad
BA	Bosnia and Herzegovina	GE	Georgia	MD	Republic of Moldova	TG	Togo
BB	Barbados	GH	Ghana	MG	Madagascar	TJ	Tajikistan
BE	Belgium	GN	Guinea	MK	The former Yugoslav Republic of Macedonia	TM	Turkmenistan
BF	Burkina Faso	GR	Greece	ML	Mali	TR	Turkey
BG	Bulgaria	HU	Hungary	MN	Mongolia	TT	Trinidad and Tobago
BJ	Benin	IE	Ireland	MR	Mauritania	UA	Ukraine
BR	Brazil	IL	Israel	MW	Malawi	UG	Uganda
BY	Belarus	IS	Iceland	MX	Mexico	US	United States of America
CA	Canada	IT	Italy	NE	Niger	UZ	Uzbekistan
CF	Central African Republic	JP	Japan	NL	Netherlands	VN	Viet Nam
CG	Congo	KE	Kenya	NO	Norway	YU	Yugoslavia
CH	Switzerland	KG	Kyrgyzstan	NZ	New Zealand	ZW	Zimbabwe
CI	Côte d'Ivoire	KP	Democratic People's Republic of Korea	PL	Poland		
CM	Cameroon	KR	Republic of Korea	PT	Portugal		
CN	China	KZ	Kazakistan	RO	Romania		
CU	Cuba	LC	Saint Lucia	RU	Russian Federation		
CZ	Czech Republic	LI	Liechtenstein	SD	Sudan		
DE	Germany	LK	Sri Lanka	SE	Sweden		
DK	Denmark	LR	Liberia	SG	Singapore		
EE	Estonia						

USE OF OSSEO-PROMOTIVE MEMBRANES IN ORTHOPAEDICS

This invention relates to the use of osseo-promotive membranes in regeneration of bone where the bone has been injured by disease, accident or surgery.

In our PCT application WO 95/10990, the use of a microporous membrane is described for sealing the junction between an implanted hip prosthesis and the bone to exclude wear particles generated by articulation of the prosthesis. Further research has shown that the sealing of bone injuries using occlusive or semi-occlusive membranes so as to exclude soft tissue cells promotes the ingrowth of the bone in the region of the injury.

According to one aspect the present invention provides for use of an occlusive or semi-occlusive membrane in the manufacture of a device for the promotion of bone ingrowth in orthopaedic surgery, wherein a bone injury is sealed by closing said injury with a membrane which is substantially inert to body fluids and is adapted to prevent ingrowth of fibrous tissues into said injury.

Preferably, the membrane is a polymer of a fluorinated monomer and may be totally non-porous to body fluids or may be semi-permeable. Where the membrane is semi-permeable, the pore sizes should not exceed 250 microns and, preferably, should not exceed 200 microns. A suitable range of pore sizes is from 0.5 micron to 200 microns.

The membrane should be bio-compatible and essentially inert to body fluids. Preferred materials are fluorinated olefins, especially perfluorinated olefins, e.g. perfluorinated ethylene and propylene. Polytetrafluoroethylene is currently preferred.

Where the membrane is semi-permeable, an expanded polytetrafluoroethylene is preferred.

Methods of producing such a membrane are known and described, for example, in US Patents Nos. 3,953,566 and 4,187,390. An example of one commercially available and suitable product is the micro-porous PTFE material manufactured by W. L. Gore Associates Ltd., under the trade mark "Gortex e-PTFE".

In one embodiment of the invention the membrane is a laminate of at least two layers of material. One of the layers may have a pore size which is large enough to be penetrated by soft, fibrous tissue cells, e.g. at a size greater than 250 microns. An adjacent layer may be totally occlusive or have much smaller pore openings so that fibrous soft tissue cells cannot penetrate the second layer. Typically, the membrane, whether a single sheet or a laminate, may be up to about 1 to 1.5 mm thick, preferably from about 300 to 1000 microns thick. In use, the occlusive or semi-occlusive layer having small particle sizes is positioned adjacent the bone injury so that soft fibrous cells cannot penetrate into the space created and sealed off by the membrane. Preferably, the laminate comprises at least three layers, the layer adjacent the bone injury is occlusive or contains only pore openings having an average size less than 250 microns, preferably less than 200 microns. A three-layer laminate in which the control layer has the smaller pore size is preferred, since it is symmetrical and can be used reversibly. Similarly, multi-layer laminates in which the outer layers are of the same or similar larger pore sizes are also advantageous. In two layer or multi-layer membranes, the layers are preferably welded together.

While the membranes can be sutured to bone or tissue to seal off the injured site, the inventors have discovered that one effective procedure is to adhesively bond the edges of the membrane around the perimeter of the injury. Suitable adhesives include medical grade cyanoacrylate polymers (commonly known as super glues), and the adhesive material sold under the trade mark "Histoacryl blue" by B. Braun Melsungen A.G. is currently preferred.

Another method of sealing the ends of the membrane is to pass a ligature, such as a loop of metal wire, around the bone and to tighten the loop around the base. Alternative methods of fixing the membrane to the bone include staples or pins. Of course, a combination of these fixing methods may be employed.

It has been found to be advantageous in use to employ a semi-occlusive membrane or one which has a layer partially or wholly penetrable by fibrous, soft tissue cells since the ingrowth of soft tissue cells into a membrane, but not through it, helps to stabilise the seal and hold the seal in place after the suturing or adhesive bond has aged.

Examples of the use of the occlusive or semi-occlusive membranes of the invention will now be described with reference to the accompanying drawings, in which:-

Figure 1A shows a section through a hip prosthesis inserted in a femur;

Figure 1B shows a similar view with a membrane fitted over and sealing the gap between the prosthesis and the hole formed to receive the bone;

Figure 2A shows a bone which has suffered a severe fracture;

Figure 2B depicts the invasion of soft tissue into the fracture hindering bone regeneration;

Figure 2C illustrates bone formation promoted by fitting of a membrane around the injury;

Figure 3A illustrates bone defect caused by surgery to remove a tumour in which a prosthesis has been fitted to replace the bone which has been removed;

Figure 3B illustrates the use of a membrane to promote bone growth.

Figure 4A illustrates the situation where an intramedullary rod has been inserted into a bone;

Figure 4B illustrates the use of a membrane to prevent fibrous tissue ingrowth.

Referring to Figures 1A and 1B, these Figures illustrate the situation in which a hip replacement prosthesis has been inserted into a femur (2) leaving a junction (3) between the edge of the hole cut in the head of the femur and the prosthesis. It has been found that especially where the prosthesis does not fit snugly into the canal cut in the femur or where bone cement is used, this can sometimes shrink away from the prosthesis or the hole cut in the bone, thus enabling fibrous tissue cells to enter the interior of the bone. In time, this will generate an ingrowth of soft tissue within the spaces between the bone and the prosthesis which is indicated at (4), which prevents generation of bone in these areas. By fitting an occlusive or semi-occlusive membrane of the kind described above to seal completely any existing or possibly future gaps forming between the prosthesis and the bone (indicated at (5) in Figure 1B), the intrusion of fibrous tissue in the space between the prosthesis and the bone is prevented. This will promote in time the slower rate of ingrowth of bone in the areas

indicated at (6) in Figure 1B, and this will maintain the stability of the prosthesis and, in time, the bone ingrowth may further lock the prosthesis into place.

The membranes used in accordance with the present invention may be resorbable over time but this is not essential and the polyfluorinated membranes described above are generally not resorbable. This is not a disadvantage since these materials have long term bio-compatibility. The presence of the membrane overlaying the fracture area creates a beneficial environment beneath the membrane for bone formation. This results in a lower incidence of delayed union or non-union of the bone with the surface of the prosthesis. The edges of the membrane are preferably bonded to the bone and to the prosthesis, e.g. by means of an adhesive, preferably a cyanoacrylate adhesive.

Referring to Figures 2A to 2C, this illustrates the use of the membrane to promote the growth of bone to repair a fracture. In the case of severe and compound fractures where the bone has been broken into small segments or splintered, regenerative bone ingrowth is slow and it may be necessary to insert one or more surgical pins, nails or rods, to hold the fragments of bone together. Even with such devices, after the surgical repair there are a number of gaps or openings into the interior of the bone into which soft tissue cells can penetrate. Where such tissue does enter the bone, it can prevent or substantially reduce the rate at which bone ingrowth will occur to form a long term healing of the fracture.

In accordance with this invention, this process is promoted and speeded up by creating an enclosed fracture site (10) after fixing the fragments in place using an occlusive or semi-occlusive membrane (11). The membrane (11) may be sealed to

its self and to the upper and lower portions of the bone to prevent ingress of fibrous tissue material into the fracture site. By preventing the competitive growth of fibrous tissue within the injured bone by sealing the cavity with the resorbable or non-resorbable membrane, bone formation will be promoted. In addition, the membrane will confine growth factors present in the bone and other bone-inducible agents or materials such as an allograft or autograft to the defect site and in the vicinity of the healing bone. For large implants or complex nailing and pinning, one of the advantages will be that increased bone growth will result in a decrease in the loosening of the implant or fixing device.

Figures 3A and 3B illustrate the application of the invention to surgical treatment of bone tumour. Referring to Figure 3A, a bone (20) has been cut away to remove the tumour and a replacement implant (21) fitted into the healthy bone. In this embodiment, the implant (21) having a fixing stem (21a) may be fitted into the healthy bone using a bone cement (22), and the implant may be provided with a surface treatment of hydroxy-apatite, especially to the stem, to promote bonding of the bone to the surface of the implant. A blood clot may form or be artificially induced at the junction (23) between the implant and the bone and this area is sealed as shown in Figure 3B by wrapping the area with a membrane (24). The membrane (24) is fixed as by gluing to the implant and to the bone to create a space (25) within which bone growth is promoted to bond the healthy bone to the implant. Alternatively, the membrane may be sealed around the bone by positioning wires (101) & (102) around the ends of the membrane and tensioning the wires to form seals between the membrane and the bone or implant.

Figures 4A and 4B illustrate a similar use of the membranes in accordance with the invention in which an intramedullary rod having an hydroxy apatite coated collar (31) having a fixing stem (31a) is introduced into a damaged bone (30) using a bone cement (32). Again, a blood clot material (33) is formed or induced around the junction between the intramedullary rod and the bone and this area is wrapped with a membrane (34) in accordance with the invention.

CLAIMS:-

1. Use of an occlusive or semi-occlusive membrane in the manufacture of a device for promotion of bone growth in orthopaedic surgery, wherein a bone injury is sealed by closing said injury with a membrane which is substantially inert to body fluids and is adapted to prevent ingrowth of fibrous tissue into said injury.
2. Use according to claim 1 in which the membrane is a polymer of a fluorinated monomer.
3. Use according to claim 1 or 2 wherein the membrane is a semi-permeable membrane having average pore sizes of not more than 250 microns.
4. Use according to claim 3 wherein the average pore size is between about 0.5 micron and 200 microns.
5. Use according to any one of the preceding claims wherein the device includes an adhesive layer for bonding edges of the membrane to tissue around the bone injury.
6. Use according to claim 5 wherein the adhesive is a cyanoacrylate adhesive.
7. Use according to any one of claims 1 to 4 in which the device includes a ligature for holding the membrane in intimate contact with bone or an implant.
8. Use according to any one of the preceding claims in which the membrane is a laminate of at least two layers comprising a first layer having openings of a size which are adapted to be penetrated by fibrous soft tissue, and a second layer which is non-porous or has pores which are too small to be penetrated by soft tissue, the second layer being adapted to lie adjacent the bone injury.

9. Use according to claim 8 wherein the laminate comprises at least three layers, and wherein the first layer comprises an internal layer and the second layers lie outside said first layer.

10. Use according to any one of the preceding claims wherein the bone injury is caused by a fracture or surgical removal of bone following diagnosis of a bone tumour.

11. Use according to any one of the preceding claims wherein the bone injury is caused by surgical insertion of a prosthesis, nail or rod.



Fig. 1A

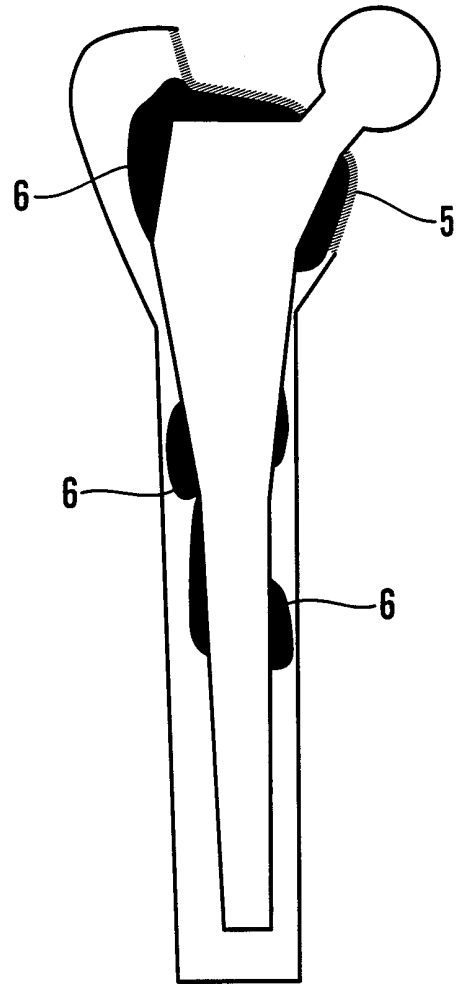

Fig. 1B

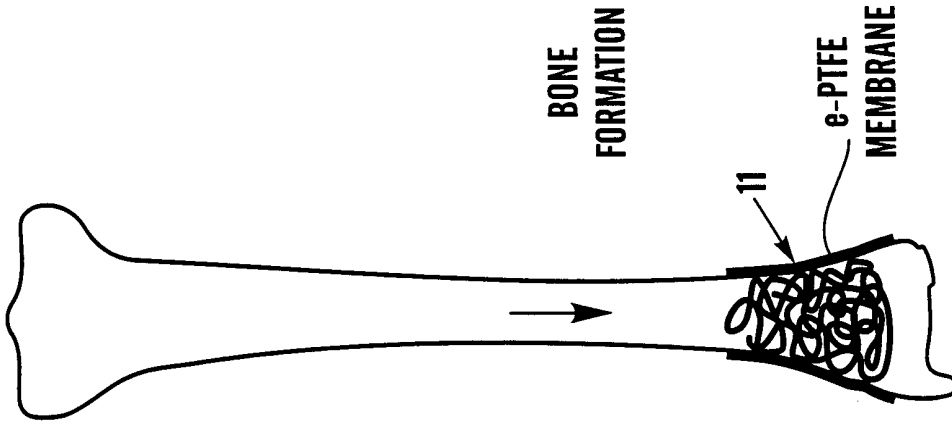

Fig. 2C

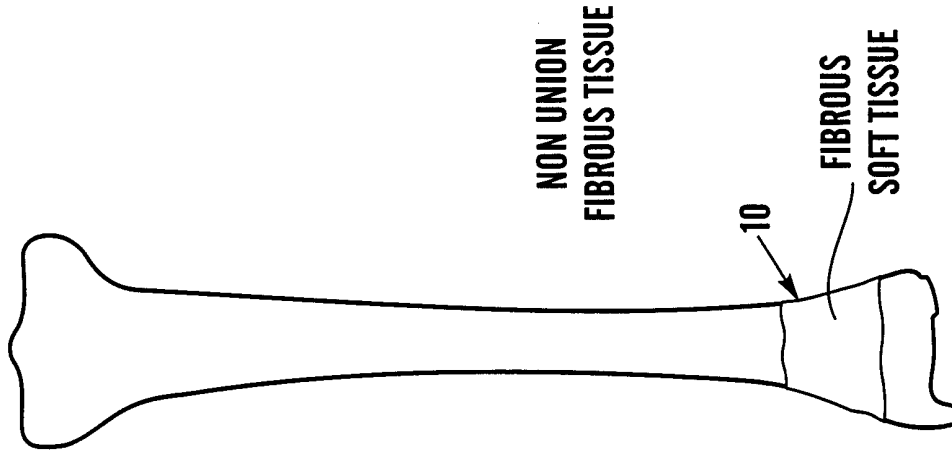

Fig. 2B

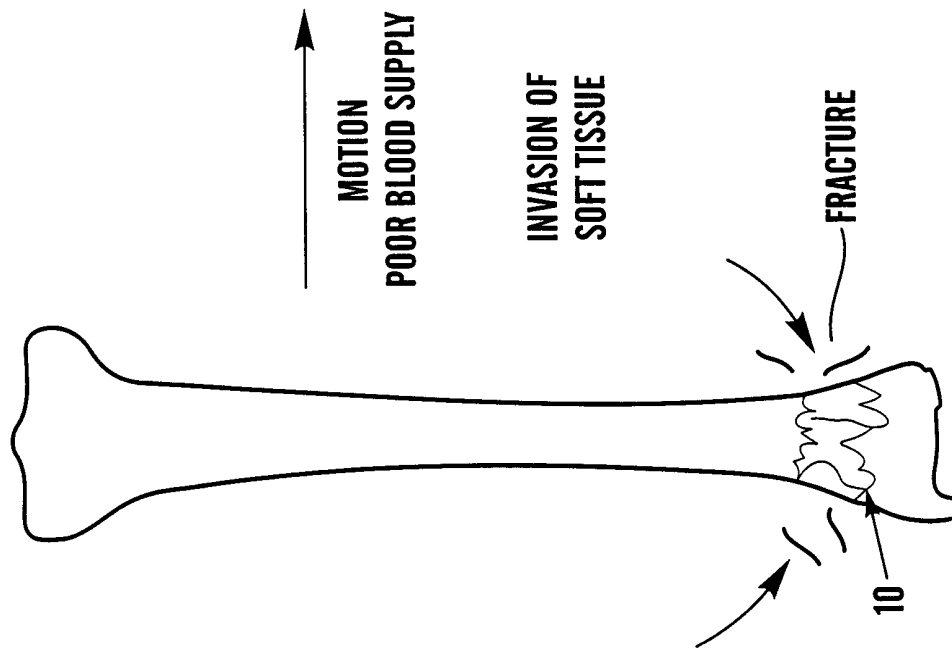

Fig. 2A

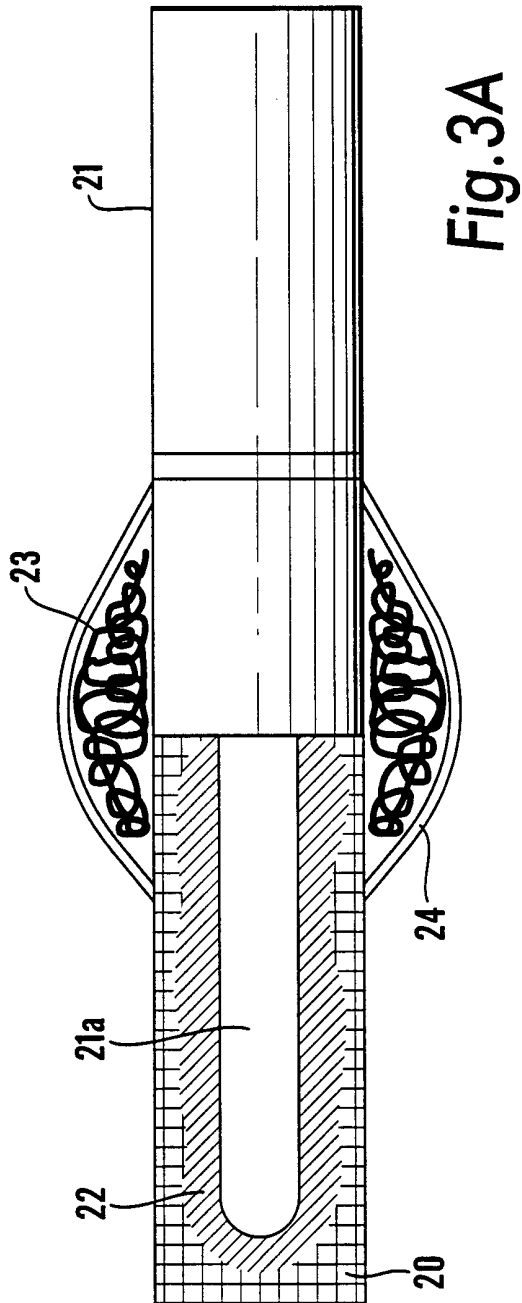

Fig. 3A

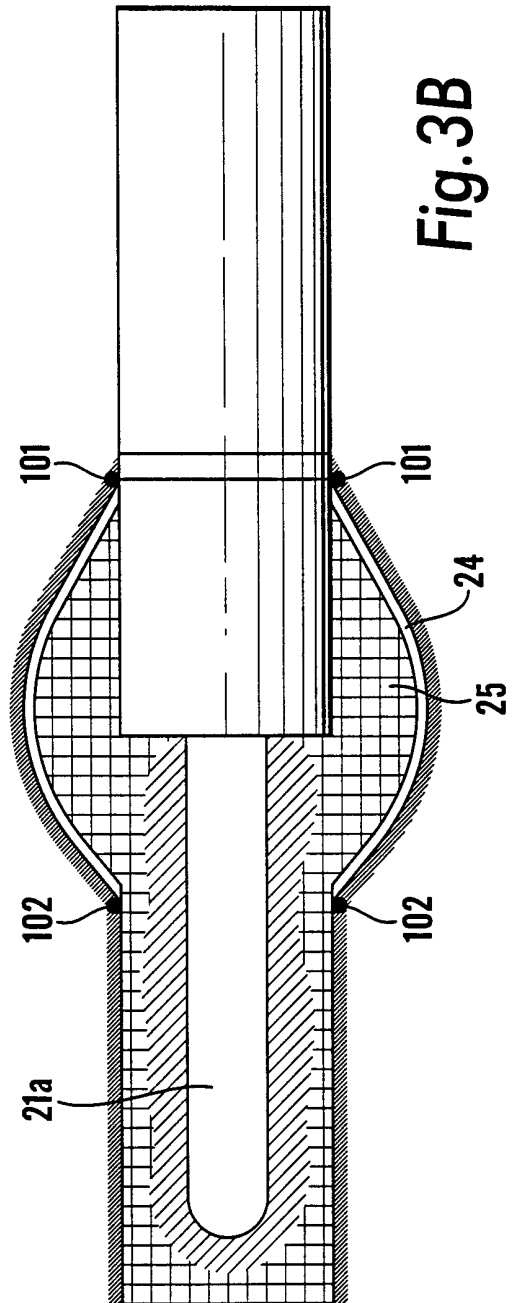

Fig. 3B

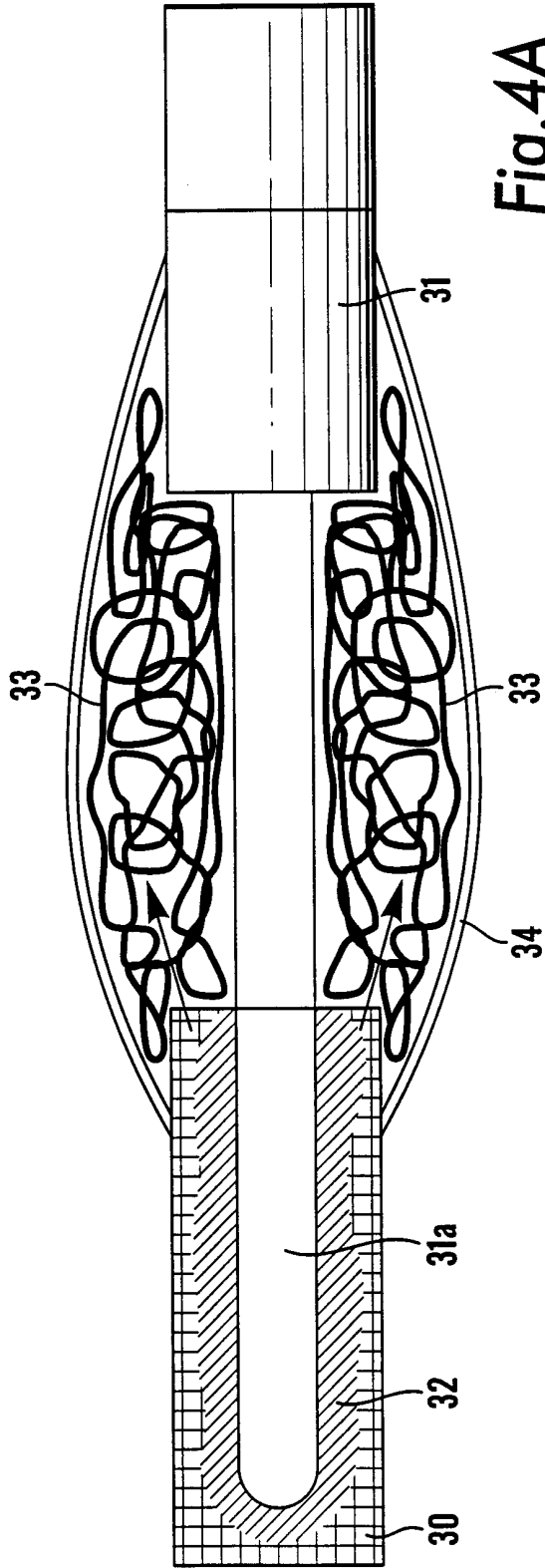

Fig. 4A

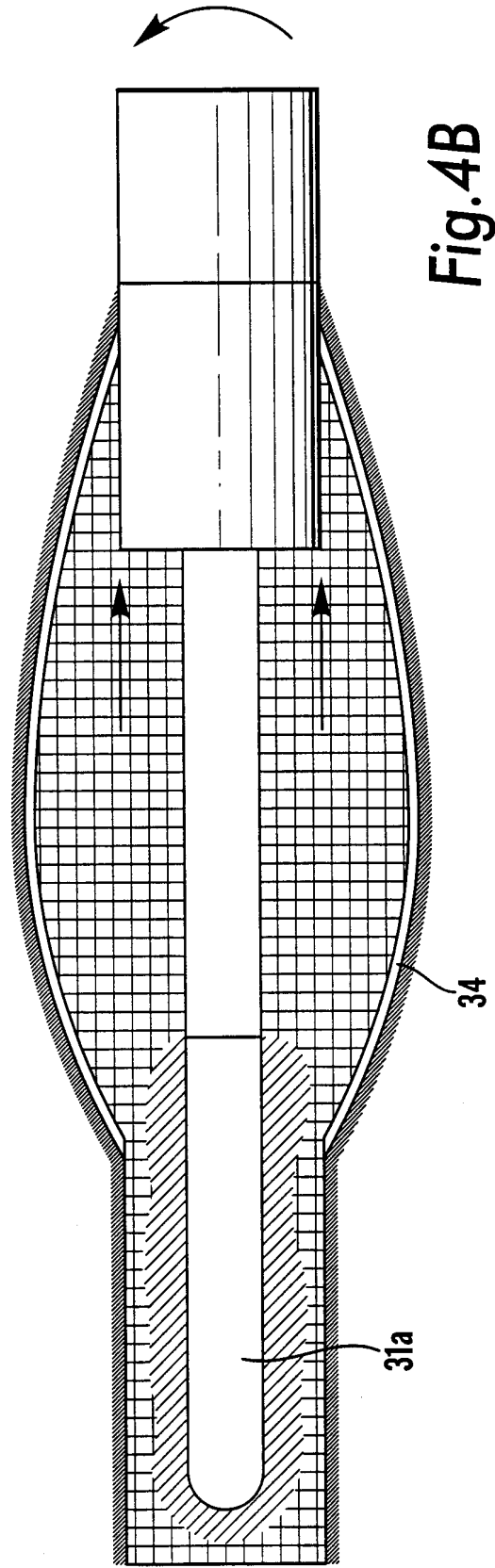

Fig. 4B