

(19) **DANMARK**

(10) **DK/EP 2733295 T3**



(12) **Oversættelse af  
europæisk patentskrift**

Patent- og  
Varemærkestyrelsen

- 
- (51) Int.Cl.: **E 06 B 3/663 (2006.01)** **E 06 B 3/964 (2006.01)** **E 06 B 5/11 (2006.01)**
- (45) Oversættelsen bekendtgjort den: **2017-08-28**
- (80) Dato for Den Europæiske Patentmyndigheds bekendtgørelse om meddelelse af patentet: **2017-05-03**
- (86) Europæisk ansøgning nr.: **13075074.8**
- (86) Europæisk indleveringsdag: **2013-11-19**
- (87) Den europæiske ansøgnings publiceringsdag: **2014-05-21**
- (30) Prioritet: **2012-11-19 DE 202012011040 U**
- (84) Designerede stater: **AL AT BE BG CH CY CZ DE DK EE ES FI FR GB GR HR HU IE IS IT LI LT LU LV MC MK MT NL NO PL PT RO RS SE SI SK SM TR**
- (73) Patenthaver: **Isophon Glas GmbH, An der Breite 18, 34346 Hann. Münden, Tyskland**
- (72) Opfinder: **Bold, Torsten, Am Entenbusch 23, 34346 Hann. Münden, Tyskland**
- (74) Fuldmægtig i Danmark: **RWS Group, Europa House, Chiltern Park, Chiltern Hill, Chalfont St Peter, Bucks SL9 9FG, Storbritannien**
- (54) Benævnelse: **Glaspartienhed**
- (56) Fremdragne publikationer:  
**EP-A2- 2 270 307**  
**WO-A1-96/33334**  
**DE-U1-202008 001 346**  
**US-A- 3 837 129**



## Description

The invention relates to a glazing unit, in particular a glazing unit for windows and doors of the type specified by the preamble  
5 of claim 1.

Glazing units of this type are known in various embodiments and are used for example in buildings such as administrative centres, financial institutes, research facilities and other  
10 buildings concerned with security measures or confidentiality requirements, where there is an increased need for protection against break-in. The glazing units are also used in land-based vehicles, such as vehicles protected against firearms ammunition and explosives, ships and aircraft. In addition, glazing units  
15 of this type are also used in buildings where protection against escape from the building must be ensured, for example in prison buildings, closed medical facilities, or young offenders institutions. Lastly, the glazing units are also used to protect against break-in via unlockable escape doors in buildings such  
20 as schools or other buildings accessible to the public, such as hospitals, concert halls, theatres, opera houses, and the like.

Beyond the usual construction of insulating glazings, glazing units of this type comprise an anti-break-in thermoplastic  
25 panel, for which polycarbonate is used primarily. Here, besides a fastening of the panes in the edge region ensuring the necessary security against break-in and/or against being broken through, the different material properties must also be taken into account. The fixing of silicate glass panes and a  
30 thermoplastic pane, such as a polycarbonate pane, thus requires a flexible mount or fixing allowing for the different thermal expansion of the two materials.

A window and a window glazing are known from patent specification  
35 EP 0 963 171 B1, in which a shatter-proof thermoplastic panel is received between two glass panels. The thermoplastic panel, which has a smaller area compared to the glass panels, is received between the first and second glass panel by a U-shaped

connecting rib provided from an edge region to corresponding edge regions. Here, the outer edge of the break-proof thermoplastic panel is surrounded by a channel. A desiccant is disposed in the U-shaped connecting rib and is provided to dry the gaps between each of the two glass panels and the thermoplastic panel. The channel of the connecting rib is extended with the aid of two overhangs, which extend along each side of the thermoplastic panel beyond the main body of the connecting rib so as to have a sufficient length for adaptation to a thermal expansion of the thermoplastic panel over a normal ambient temperature range. This results in the disadvantage that the thermoplastic panel is mounted lying above a fixing of the window glazing unit.

Patent publication WO 96/33334 also discloses a window glazing unit in which a break-proof plastic pane is received in an airtight manner at the edge between two silicate glass panes. The plastic pane is received by a U-shaped profile along its edge, which U-shaped profile is provided at a distance from each of the parallel silicate glass panes with the aid of a spacer element in each case. The U-shaped profile is connected to the spacer elements using a primary sealant and is secured at its base piece between the silicate glass panes using a secondary sealant. A disadvantage of the mounting of the plastic pane in the window glazing unit according to WO 96/33334 is the fact that it is formed in three parts in the edge region of the thermoplastic pane. This is because the forces introduced via the plastic pane in the event of an attempt to break in or through the window glazing unit have to be absorbed by the spacer elements and the secondary sealant.

A further multiple glazing unit is known from US patent 3 837 129, in which at least one pane made of a thermoplastic material, such as polycarbonate, is also received between two glass panes in a manner sealed outwardly at the edge. The pane made of the plastic material is guided here in a U-profile along its edge region. The U-profile receives the pane made of plastic material resiliently, wherein the legs of the U-profile are

pushed outwardly and each bear against the pane made of plastic material by means of a bead region arranged toward the opening of the U-profile. Each leg of the U-profile has an abutment section externally, which abutment sections are each supported  
5 on a spacer piece secured between the pane made of thermoplastic material and one of the silicate glass panes respectively. Due to the resilient mounting of the thermoplastic pane, high impact energies can be absorbed without the thermoplastic pane fracturing or breaking. A disadvantage of the multiple glazing  
10 unit according to US 3 837 129 is the complex assembly inclusive of the high material consumption, which is also costly. The profile protrudes into the visible region of a window provided with the multiple glazing unit, which is visually disadvantageous. The security provided against the glazing unit  
15 being broken through could also be improved.

US patent 4 368 226 also discloses a glass unit in which a polycarbonate panel is received in parallel between two planar glass layers. Edges of the polycarbonate panel are received in  
20 a U-shaped channel in such a way that a lateral expansion of the panel is possible. The polycarbonate panel is provided at a distance from each of the glass layers by hollow-body-like spacer elements. The edges of the two glass layers and the polycarbonate panel are surrounded by a stable U-shaped holder,  
25 made for example of a metal, to provide protection outwardly. The gap between the holder, the glass layers, the polycarbonate panel and the U-shaped channel is filled with a first sealing compound. A second sealing compound such as butyl for fixing the spacer elements is provided between these spacer elements and  
30 each of the glass layers and the polycarbonate panel. A desiccant filled into the spacer elements dries the gaps between the polycarbonate panel and each of the glass layers via an opening channel in the spacer elements. The edging of the glass unit with the U-shaped metal holder constitutes an additional process  
35 step in the manufacture of the glass unit, which has proven to be disadvantageous in terms of time and cost.

The object of the invention is therefore to simplify the

production and handling of the glazing unit of the type in question whilst avoiding the disadvantages of the prior art.

Proceeding from the features of the preamble of claim 1, the  
5 object is achieved by the characterising features of claim 1.

Accordingly, at least one supporting element is provided in at least one edge section on the receiving element of a glazing unit according to the invention serving to receive a  
10 thermoplastic panel. In accordance with the invention, the force of the weight of the thermoplastic panel is thus transferred to a substrate receiving the glazing unit according to the invention, such as glazing blocks, which are inserted into a frame introduced into a building opening.

15

The direct support of the thermoplastic panel on a substrate receiving the glazing unit in a building advantageously increases the security against the glazing unit being broken through, because the substrate serves as an abutment. The  
20 invention also provides the advantage of a vertical handling and storage of the glazing unit already during the first production steps. A significant reduction of what are known as the blocking wedges necessary when assembling the glazing unit in a building or the like also constitutes a further advantage. The adhesives  
25 of the edge seal of the glazing unit are also advantageously freed from or relieved of the mass of the thermoplastic panel otherwise exerting a load there, such that the load acting on the edge seal corresponds to that of a normal triple glazing.

30 Further advantages will become clear from the dependent claims.

In a further development of the invention the at least one supporting element extends across the at least one edge section. A plurality of supporting elements can be provided at a distance  
35 from one another in the area of at least one edge section of the glazing unit so as to form a contact surface of the glazing unit together with the first and/or second glass panel. The supporting elements can be provided one behind the other or

parallel to one another. The glazing unit according to the invention preferably has at least one supporting element at all edge sections.

5 The at least one supporting element can have at least two supporting sections in another embodiment of the present invention, i.e. can be designed as a multiple-member part, for example as a double web or multiple web. The at least one supporting element then preferably has a substantially W-shaped  
10 cross-section. If at least two supporting sections are provided at the receiving element, these can be provided parallel to one another and/or offset in relation to one another.

The at least one supporting element in accordance with the  
15 invention can be connected to the receiving element. The supporting element then designed as a supporting projection can be connected to the receiving element or can be integrated thereon. Besides a preferably one-piece design of the receiving element at least in the region of an edge section, the at least  
20 one supporting element or the at least one supporting projection can also be connected as a separate part to the receiving element in a form-fitting and/or non-positive manner at the time of assembly of the glazing unit. If the at least one supporting element is connected to the receiving element, it is preferably  
25 formed as a fin-like supporting projection.

Alternatively, the supporting element in accordance with the invention can be provided in a manner abutting against the outside of the receiving element. In accordance with the  
30 invention, the at least one supporting element then preferably has a trapezoidal cross-section and is introduced from the edge of the glazing unit until it bears against the receiving element and can thus receive and support the load of the thermoplastic panel. For example, square or rectangular cross-sections are of  
35 course also conceivable.

The supporting element can preferably also be connectable in a non-positive or form-fitting manner to a frame profile or the

like receiving the glazing unit. The glazing unit is thus fixed in a stable manner in a building or the like with an increase of the security provided against the glazing unit being broken through.

5

In a further embodiment of the glazing unit the at least one spacer element is designed as a spacer that can be fixed between the receiving element and one of the glass panels. The spacer can then be fixed between the glass panel and the receiving  
10 element of the thermoplastic panel using a first adhesive sealant, which closes off the gap between the thermoplastic panel and the corresponding glass panel to the edge. Both spacer elements are preferably designed as separate spacers which are fixed accordingly between the glass panel and the receiving  
15 element of the thermoplastic panel using a first adhesive sealant.

The invention also provides the advantage of integrating standardised spacers in the glazing unit between a thermoplastic  
20 panel and a glass panel. Due to the selection of spacers of different width, a modular and flexible construction of the glazing unit is provided. The provision of the desiccant in the spacers designed similarly to hollow bodies enables a reduction of the height of the receiving element. A flat construction of  
25 this type of a holder for the thermoplastic panel allows an accordingly deeper mounting in the region of fixing legs surrounding the glazing unit. The security against the glazing unit being broken through is thus further increased. In the case of a two-part or preferably three-part construction of the edge  
30 profile with two spacers, at least one spacer can be made of a material that is a poor thermal conductor in order to produce the conditions for what is known as a warm edge profile.

The receiving element and/or at least one spacer of an embodiment  
35 of the glazing unit according to the invention can also be formed in one piece, at least in the region of an edge section, which simplifies the production. If both spacer elements are integrated monolithically with the receiving element, a one-part

edge profile is provided. Alternatively, the receiving element and/or at least one spacer element can be formed in a number of parts. Here, the receiving element and/or the at least one spacer element can be produced from their/its individual parts by being  
5 clipped together or glued.

In one embodiment of the glazing unit according to the invention the receiving element, on its sides opposite the thermoplastic panel, has a supporting section whose lateral expansion is  
10 smaller than the width of the spacer elements. The spacer elements can be provided opposite a side, aligned towards the interior of the glazing unit, of the supporting sections of the supporting element, and they jut out towards the glass panels.

15 The receiving element can have at least one hollow cavity or an essentially C-shaped recess to receive connecting elements for connection of a plurality of receiving elements to surround the entirety of the thermoplastic panel. At least one supporting section preferably has the at least one hollow cavity, which can  
20 also be filled with desiccant. Furthermore, the at least one hollow cavity can also serve to receive a stabilisation or reinforcement element made for example of steel to stabilise the glazing unit. It is also possible to introduce legs of elbows at the corners of the glazing unit into hollow cavities  
25 preferably of the supporting sections of two edge sections abutting one another. The surrounding receiving elements are thus connected in a stable manner, and the thermoplastic panel is thus surrounded. If the receiving elements at the four edges of the glazing unit are butted against one another or mitred,  
30 knee-shaped connection pieces can be introduced into the hollow cavities of supporting sections abutting one another.

If a channel-like grooving for receiving or for binding material of the first adhesive sealant is mounted externally on each leg  
35 of the receiving element delimiting the U-shaped receiving groove towards the free end of said receiving element, an escape of the material of the first adhesive sealant into the interior of the glazing unit can thus be prevented advantageously. The

first adhesive sealant is preferably designed as a permanent elastic butyl-rubber sealant.

5 Another embodiment of the glazing unit according to the invention is characterised by a spring-loaded element provided in the receiving groove of the receiving element. The spring-loaded element is formed in one embodiment from an elastic material which has good recovery properties and which preferably can contain a desiccant. Among other things, the spring-loaded  
10 element can be designed as a silicone foam with good recovery properties. The silicone foam preferably contains a desiccant. The spring-loaded element can also be designed as a spring-like lip pointing away from the base of the receiving groove of the receiving element in the area of at least one edge section. Both  
15 embodiments of the spring-loaded element are intended to prevent a setting-down or contacting of the thermoplastic panel, which is movable in the receiving groove, on the base of said groove. The spring-like lip preferably protrudes from one of the legs in the area of the groove base. The spring-like lip can also be  
20 designed as a projection of a spring element which can be inserted in the receiving groove. The spring-loaded element can be manufactured from materials having different recovery properties.

25 In a preferred embodiment of the glazing unit according to the invention, a space surrounded by the first and second glass panel, the spacers and the receiving element and open towards the edge of the glazing unit is filled with a second adhesive sealant. The second adhesive sealant can be silicone. The second  
30 adhesive sealant is preferably designed as polysulfide- or polyurethane-based two-component sealant, which, once cured, fixes the first and second glass panel and the receiving element. The end faces are preferably arranged flush with the second adhesive sealant. The end faces of the first and/or second glass  
35 panel and/or of the at least one supporting element, however, can also protrude beyond the second adhesive sealant outwardly.

Within the scope of the invention, the first and/or second glass

panel can be conventional glass panels made of a wide range of different silicates. Furthermore, they can contain different coatings or dyes and can also be designed as laminated glass. The thermoplastic panel can be formed from polycarbonate, 5 polymethylacrylate, polyethylene terephthalates and other transparent plastics. The thermoplastic panel can also be provided, perforated, or structured with holes in accordance with the invention, which is advantageous in particular for acoustic applications. Besides a one-part design, the term 10 'thermoplastic panel' in accordance with the invention also includes multi-part thermoplastic panels provided with a number of panes, which are cast, glued or laminated. The thermoplastic panel can also be designed as a hollow cavity panel.

15 In accordance with the invention, the spacers are parts made of aluminium, plastic or high-grade steel usually used in the case of window construction or the production of insulating glass panes. The receiving element according to the invention can also be produced from aluminium. However, it can also be designed 20 particularly advantageously in terms of its thermal insulation properties as a plastic element. It is also conceivable to manufacture the receiving element from silicone foam, glass fibre composite materials, steel or high-grade steel. Here, a design of the receiving element as an extruded part is 25 particularly preferred. The glazing unit according to the invention can be used as a window, door or wall glazing in buildings or also movable objects, such as land-based vehicles, watercraft and aircraft.

30 The invention will be explained hereinafter on the basis of exemplary embodiments with reference to drawings which are partly simplified and shown to different scales, and in which like parts have been provided with like reference signs. In the drawings:

35

Fig. 1 shows a cross-section through an edge section of a first embodiment of the glazing unit according to the invention,

Fig. 2 shows a cross-section through an edge section of a second embodiment of the glazing unit according to the invention,

5 Fig. 3 shows a side view of a glazing unit according to the invention in a produced state, and

Fig. 4 shows a side view of a second embodiment of the glazing unit according to the invention.

10

A glazing unit 1 according to the invention, in accordance with Fig. 1, has a thermoplastic panel 2, which is designed as a polycarbonate panel and is surrounded in parallel by a first and second glass panel 3, 4 preferably formed from fluorosilicate.

15 The polycarbonate panel 2 is inserted into a receiving groove 5 of a receiving element 6 made for example of aluminium. The receiving element 6 surrounds an outer edge 2a of the polycarbonate panel 2 peripherally. Here, the size or spacing ratios of the polycarbonate panel 2 and of the receiving element

20 6 are designed in accordance with the invention such that there is a sufficient distance between the outer edge 2a of the polycarbonate panel and a groove base 5b of the receiving groove 5, at least at two respective edge sections forming a right angle with one another. In accordance with the invention, the

25 distance is such that the difference of the coefficients of longitudinal thermal expansion of glass and polycarbonate can be more than compensated, for a temperature range corresponding to the use according to the invention. For this purpose, the length of the legs 7 of the receiving element 6 laterally

30 delimiting the receiving groove 5 is selected in accordance with the invention such that the polycarbonate panel 2 is always guided via its outer edge 2a in the receiving groove 5. This means that even in the event of a contraction of the polycarbonate panel 2 caused by a reduction in temperature, a

35 removal of the outer edge 2a via the opening 9 of the receiving groove 5 is prevented. A free space 8 between the groove base 5b and the outer edge 2a of the polycarbonate panel 2 is sufficiently large in the direction parallel to the longitudinal

extent of the panels 2, 3, 4 that the polycarbonate panel 2 is prevented from setting down on the groove base 5b in the event of a rise in temperature, wherein a setting-down of this nature would generate a stress.

5

In accordance with the invention, a spring-loaded lip 11 facing away from the groove base 5b of the receiving groove 5 is provided at least at two edge sections of the glazing unit 1 or the polycarbonate panel 2 forming a right angle so as to  
10 resiliently receive the outer edge 2a of the polycarbonate panel 2 and to the polycarbonate panel 2 disposed loosely in the glazing unit 1 in the direction of expansion of the glass panels 3, 4 from setting down on the base of the receiving groove. The material and elasticity or rigidity of the spring-loaded lip 11  
15 are such that it can absorb the thermal expansion of the polycarbonate 2. In the case of a receiving element 6 extruded for example from aluminium, the spring-like lip 11 is provided on an inner wall 7c of one of the legs 7 forming the groove 5, towards the groove base 5b. As shown in Fig. 1, the receiving  
20 element 6 has a protruding supporting section 12 in the region of the groove base 5b on both sides.

The first and second glass panel 3, 4 are each distanced from the polycarbonate panel 2 via spacers 14. The spacers 14  
25 conventional in the field of insulating glass construction and made for example of aluminium are each fixed laterally to the glass panel 3 or 4 and the legs 7 of the receiving element 6 using a primary sealant 15, such as butyl. The fixing of the spacers 14 thus terminates gaps 16 formed between each of the  
30 glass panels 3, 4 and the polycarbonate panel 2, peripherally towards the edge 1a, as considered from the supporting sections 12 towards the interior of the glazing unit 1. The primary sealant 15 in accordance with the invention must be permanently elastic in order to absorb climate burdens as a result of air  
35 pressure changes induced by changed external conditions.

The spacers 14, on their sides 14b facing towards the interior of the glazing unit 1 according to the invention, have

perforations 17, via which a desiccant 18 provided inside the hollow-body-like spacers 14 can have a drying effect on the gaps 16. The amount of desiccant 18 or the size of the spacers 14 provided therefor is calculated on the basis of the enclosed  
5 volume and the residual moisture of the polycarbonate panel or the used material. The gaps 16 can also be filled with a gas, for example a noble gas.

So as to avoid direct contact of the supporting sections 12 with  
10 the first and second glass panel 3, 4, these supporting sections are designed so as to protrude to a lesser extent than the width of the spacers 14 in relation to the legs 7, 8 of the receiving element 6. An edge space provided to the edge 1a of the glazing unit 1 according to the invention and surrounded by the first  
15 and second glass panel 3, 4, the spacers 14 and the receiving element 6 is filled with a secondary sealant 19. In accordance with the invention, the edge space is filled with the secondary sealant 19 until end faces 3a, 4a of the glass panels 3, 4 and a supporting element provided on the receiving element 6 to the  
20 edge 1a of the glazing unit 1 and formed preferably as a fin-like supporting projection 20 are flush with one another and delimit the glazing unit 1 outwardly at the edge. Consequently, the end faces 3a, 4a of the first and second glass panel 3, 4 and an end face 20a of the fin-like supporting projection 20  
25 form a contact surface of the glazing unit 1 according to the invention. In order to avoid an escape of constituents of the first adhesive sealant towards the interior of the glazing unit 1, a bead 21 for receiving or for binding material of the primary sealant is mounted externally on each of the legs 7.

30

In the second embodiment 10, shown in Fig. 2, of the glazing unit according to the invention, the supporting element 200 has a trapezoidal cross-section and forms a preferably centrally provided support for the receiving element 60. For this purpose,  
35 the supporting element 200 is pressed from outside into the secondary sealant 19 until a face 200b opposite the base face 200a of said supporting element bears against an outer side 60a of the receiving element 60.

The glazing unit 1 according to the invention, in accordance with Fig. 3, has four receiving elements 6, which are mitred at the four edges of the polycarbonate panel 2 or the glazing unit 1. In order to seal off the edge space, the supporting projections 20 provided in each case at two edge sections abutting one another are cut down in a region of approximately up to five centimetres on both sides of a connecting joint 22 and replaced by secondary sealant 19 (not shown in Fig. 2). The receiving elements 6 are connected to one another via elbows 24 inserted in each case into opposite hollow cavities 23 of the supporting sections 12 (Fig. 1).

In accordance with the invention the receiving element 6'' shown in Fig. 4 differs from the other receiving elements 6' by supporting projections 25 provided in a spaced-apart manner at its edge 6''a. Due to the supporting projections 25 at the edge section of the polycarbonate panel 2 surrounded by the receiving element 6'', this can serve as a contact surface.

It goes without saying that the designs described in Figs 3 and 4 on the basis of the first embodiment of the glazing unit according to the invention can also be transferred analogously to the glazing unit 10 differing therefrom merely in respect of the supporting element 200.

A glazing unit 1 according to the invention illustrated in Figs 1, 3 and 4 is composed from its individual components as explained hereinafter. A first glass panel 3 is first cleaned and moved into a press and is suctioned and held there by suction elements distributed over its surface area. A polycarbonate panel 2 is then surrounded by receiving elements 6', 6'', as shown on the basis of Fig. 4. To this end, the receiving grooves 5 (Fig. 1) of the receiving elements 6', 6'' are slid onto the edge sections of the polycarbonate panel 2 and are connected to one another at the corners, as illustrated in Fig. 2. A spacer 14 is then fixed on the receiving element 6, 6'' peripherally towards the edges of the polycarbonate panel 2 with the aid of

the primary sealant 15.

The polycarbonate panel 2 is then brought into an upright position in relation to the floor surface of an assembly hall and is further assembled or transported in a manner standing on the supporting projections 25 of the receiving element 6'' and is glued to a second glass panel 4 by means of the primary sealant. Here, the end face 4a of the second glass panel 4 and end faces 25a of the supporting projections 25 form a contact surface of the glazing unit 1''. The second spacer 14 is then fixed to the receiving element 6, 6'' on the other side of the polycarbonate panel 2 or surrounding the second legs 7 of the receiving elements 6', 6'', likewise using the primary sealant 15. The unit thus assembled, formed of receiving elements 6', 6'', spacers 14, polycarbonate panel 2 and second glass panel 4 is positioned congruently in front of the first glass panel 3 using an appropriate transporting or holding device. The two glass panels 3, 4 and the polycarbonate panel 2 are then introduced into a press, in which the first and second glass panel 3, 4 are fixedly connected via the spacers 14 to the receiving element 6', 6'' provided peripherally on the polycarbonate panel 2. The edge space is then filled with the secondary sealant 19 and the glazing unit 1 is stored until said sealant has cured. During this process, the placement of the unit on the projection 20 is of great advantage because the mass of the polycarbonate panel 2 is supported by the projection 20 and does not have to be supported via the sealants. The glazing unit 1'' can thus even be stored vertically until the secondary sealant has cured.

30

The at least one supporting element 200 of the glazing unit 10 can be inserted, preferably pushed in, during the production process once the edge space has been filled with the secondary sealant 19. However, it is also possible to insert the supporting element 200 subsequently into a glazing unit 10.

35

## Patentkrav

1. Glaspartienhed med i det mindste en første og anden glasplade (3, 4) og en splintfri termoplastisk plade (2), som i forhold til disse er mindre med hensyn til areal og er indrettet mellem disse, hvor glaspartienheden (1) ved sin rand (1a) er tætnet udadtil, hvor en rand (2a) af den termoplastiske plade (2) omgives af en U-formet optagenot (5) i et optageelement (6, 6', 6"; 60), der er dimensioneret sådan, at det fuldstændigt omgiver den termoplastiske plades (2) rand (2a) også i forskellige termiske udvidelses- og kontraktionstilstande, hvor den første og anden glasplade (3, 4) hver især under dannelse af et mellemrum (16) ved hjælp af et afstandselement (14) er anbragt i en afstand fra den termoplastiske plades (2) optageelement (6, 6', 6"; 60), og hvor hvert afstandselement (14) er udformet som hult legeme, der står i forbindelse med det respektive mellemrum (16) og indeholder et tørremiddel (18), kendetegnet ved, at der på optageelementet (6, 6"; 60) i området ved i det mindste et randafsnit (1a, 1"a; 10a) af glaspartienheden (1, 1"; 10) er indrettet i det mindste et støtteelement (20, 25, 200), som sammen med den første og/eller anden glasplade (3, 4) danner en understøtningsflade for glaspartienheden (1, 1"; 10).
2. Glaspartienhed ifølge krav 1, kendetegnet ved, at det i det mindste ene støtteelement (20; 200) er udvidet ud over det i det mindste ene randafsnit (1a) af glaspartienheden (1).
3. Glaspartienhed ifølge krav 1 eller 2, kendetegnet ved, at der i området ved i det mindste et randafsnit (1a, 1"a; 10a) af glaspartienheden (1, 1") er indrettet flere støtteelementer (25) med afstand til hinanden.
4. Glaspartienhed ifølge et af kravene 1 til 3, kendetegnet ved, at det i det mindste ene støtteelement har i det mindste to støtteafsnit.
5. Glaspartienhed ifølge et af kravene 1 til 4, kendetegnet ved,

at det i det mindste ene støtteelement er udført som støttefremspring (20, 25), der er monolitisk med optageelementet (6; 6").

5 6. Glaspartienhed ifølge et af kravene 1 til 4, kendetegnet ved, at det i det mindste ene støtteelement (200) på ydersiden ligger an mod optageelementet (60).

7. Glaspartienhed ifølge et af kravene 1 til 6, kendetegnet ved,  
10 at det i det mindste ene støtteelement kan forbindes form- og/eller kraftsluttende med optageelementet (6; 6"; 60).

8. Glaspartienhed ifølge et af kravene 1 til 7, kendetegnet ved, at optageelementet (6, 6', 6"; 60) på sine fra den termoplastiske  
15 plade (2) bortvendte sider har et understøtningsafsnit (12), hvis sideværts udstrækning er mindre end afstandselementets (14) bredde.

9. Glaspartienhed ifølge krav 8, kendetegnet ved, at  
20 afstandselementerne (14) er indrettet liggende over for en mod glaspartienhedens (1, 1"; 10) indre rettet side af optageelementets (6, 6', 6"; 60) understøtningsafsnit (12) og rager ud over disse hen imod glaspladerne (3, 4).

25 10. Glaspartienhed ifølge et af kravene 1 til 9, kendetegnet ved, at optageelementet (6, 6', 6"; 60) har i det mindste et hult kammer (23) eller en i det væsentlige C-formet udtagning til optagelse af forbindelseselementer (24) med henblik på  
30 forbindelse af flere optageelementer (6, 6', 6"; 60) til omløbende indfatning af den termoplastiske plade (2) eller af stabiliseringselementer til stabilisering af glaspartienheden (1, 1", 10).

11. Glaspartienhed ifølge krav 10, kendetegnet ved, at  
35 forbindelseselementerne (24) er udført som vinkelstykker.

12. Glaspartienhed ifølge et af kravene 1 til 11, kendetegnet ved et fjedrende element, der er indrettet i optageelementets

(6, 6', 6"; 60) optagenot (5).

13. Glaspartienhed ifølge krav 12, kendetegnet ved, at det fjedrende element er udført som en fjederagtig læbe (11), der peger bort fra bunden (5b) af optageelementets (6, 6', 6"; 60) optagenot (5).

14. Glaspartienhed ifølge krav 13, kendetegnet ved, at den fjederagtige læbe (11) rager frem fra et af benene (7) i notbundens (5b) område.

15. Glaspartienhed ifølge krav 13 eller 14, kendetegnet ved, at den fjederagtige læbe er udført som fremspring af et fjederelement, der kan indskydes i optagenoten (5).

16. Glaspartienhed ifølge krav 12, kendetegnet ved, at det fjedrende element er dannet af et tilbagestilleligt, elastisk materiale, der indeholder et tørremiddel.



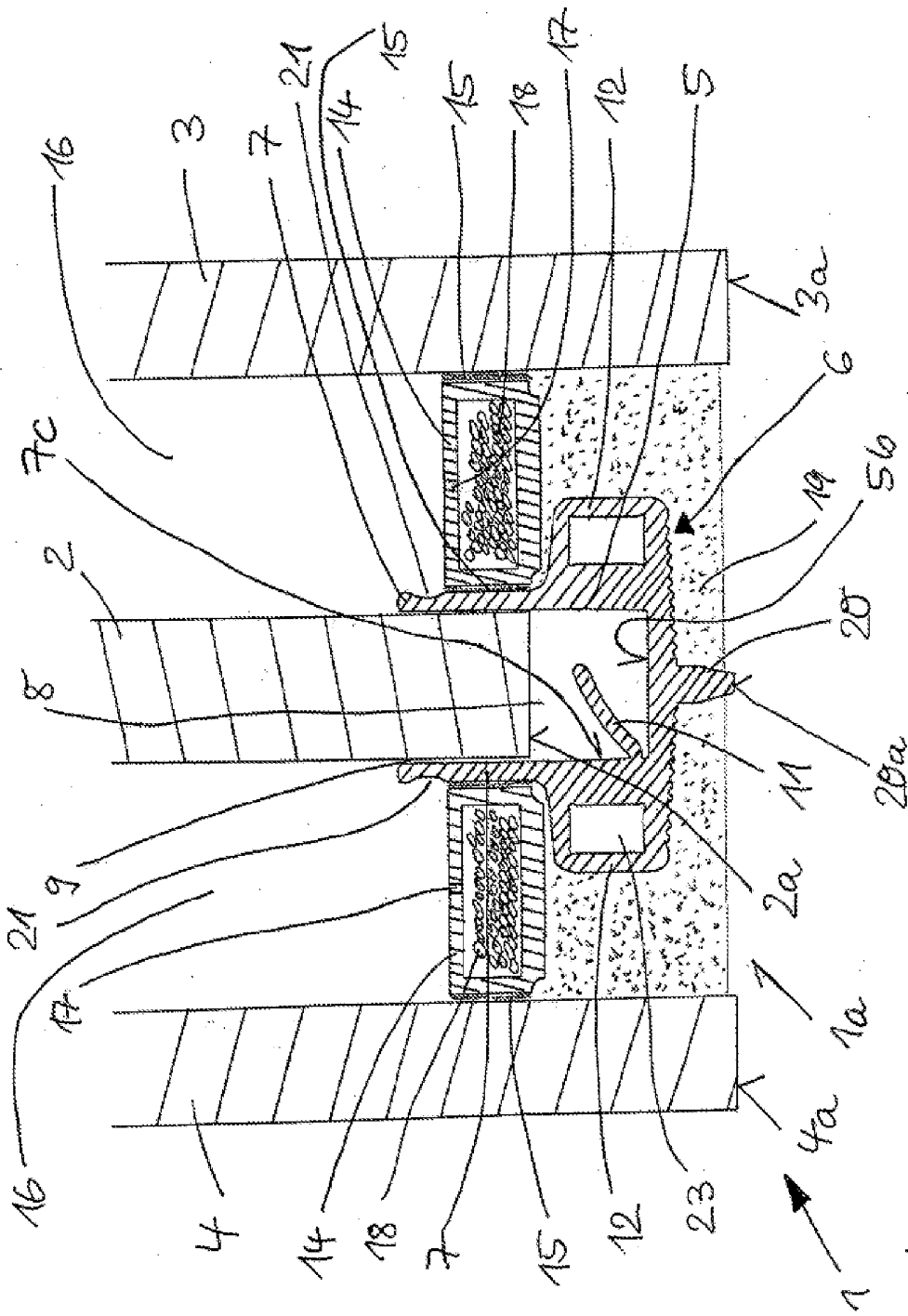

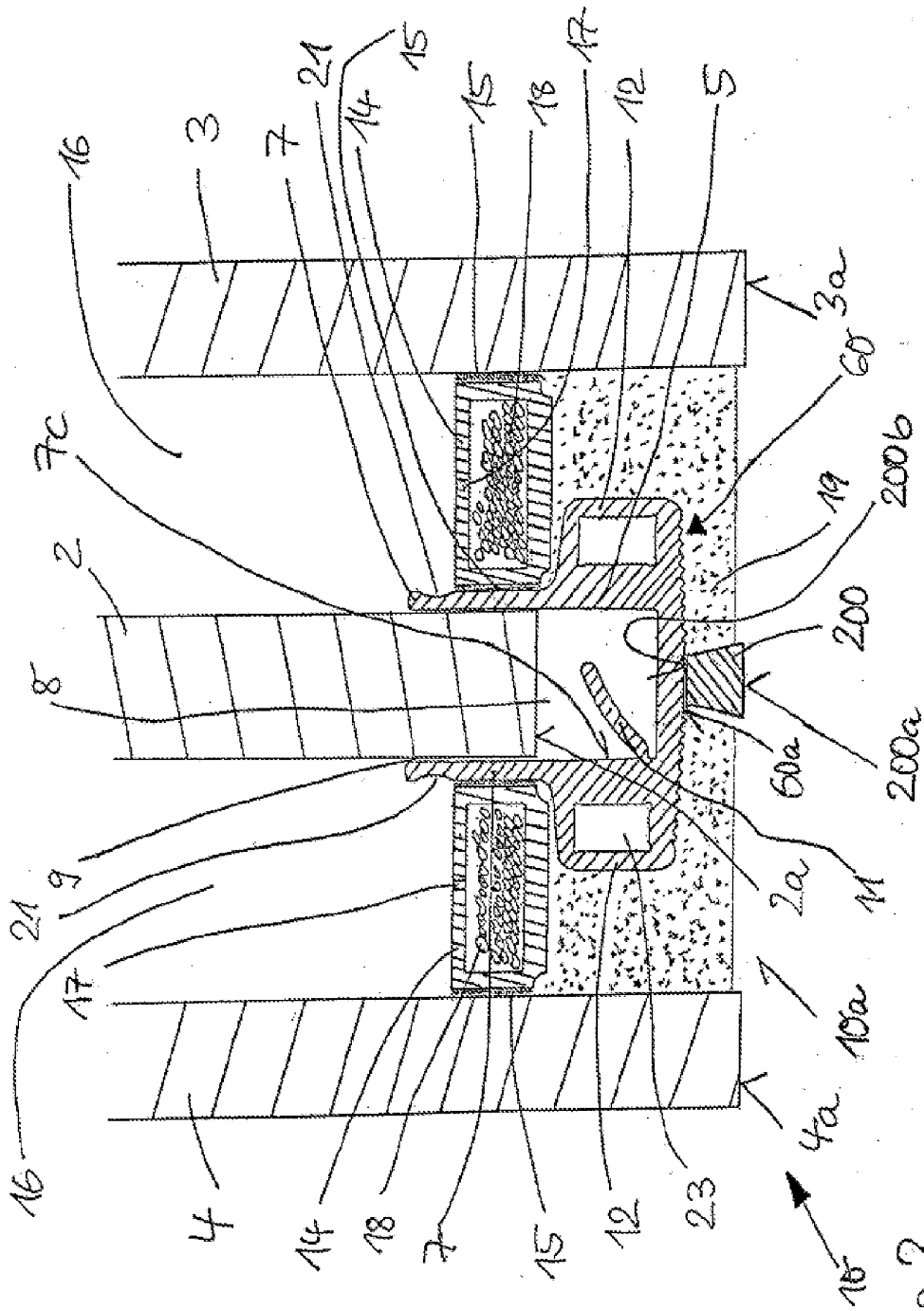

Fig. 2

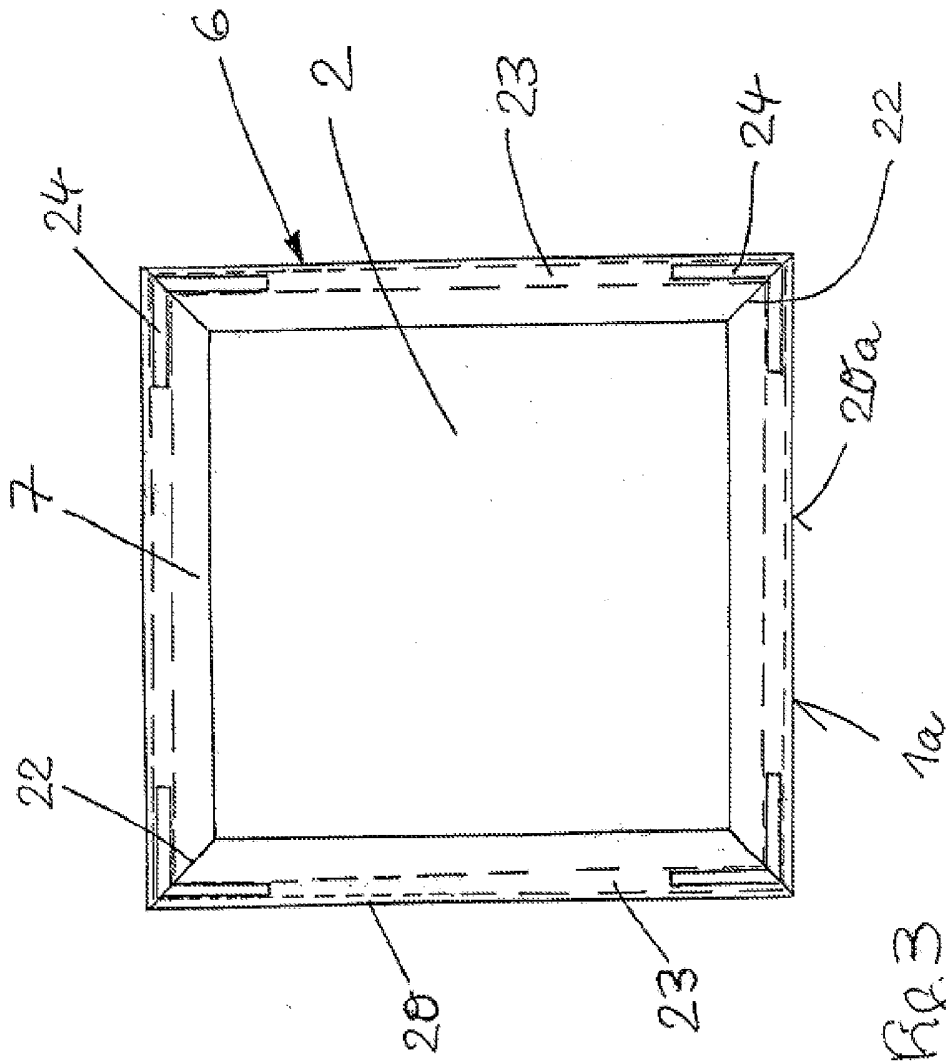

Fig. 3  
1a