

Feb. 20, 1962

S. A. YOUNG

3,022,014

SHOWER HEAD

Filed Nov. 12, 1958

FIG. 1

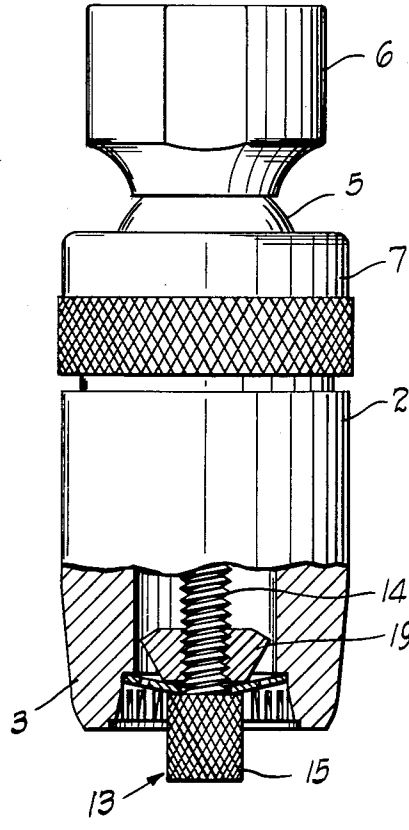
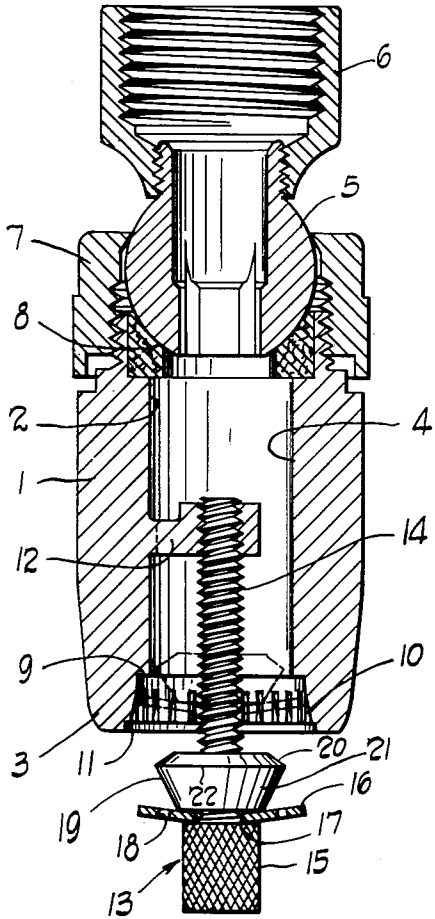

FIG. 2

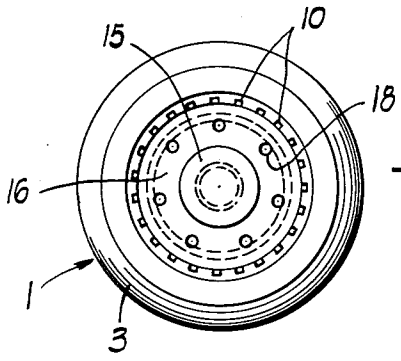

FIG. 3

INVENTOR.  
S. A. YOUNG  
BY *Robb & Robb*  
attorneys

1

3,022,014

SHOWER HEAD

Stephen A. Young, R.D. 4, Monticello, Ind.

Filed Nov. 12, 1953, Ser. No. 773,325

2 Claims. (Cl. 239-438)

This invention relates to shower heads and more particularly to the type of shower head designed to be as economical of water use as possible.

In shower heads of the class generally referred to herein, the same are commonly of relatively small size so as to reduce the possible flow therethrough and thus in effect limit the amount of water used thereby as an overall consideration.

In shower heads of this class, many problems arise, particularly related to the type of water with which the shower heads may be used and in this connection the difficulty resides in the various particles of one kind or another which are deposited within the shower head and thus require that the same be cleaned out periodically. If such shower heads are not cleaned out periodically or provided with means for cleaning the same, the accumulations or deposits from water of various hardnesses eventually stops the flow completely and makes the shower head ineffective to carry out its intended purposes.

With the foregoing background in mind, the shower head of this invention contemplates the provisions of a small type of shower head, through which sufficient water flows to provide adequately for bathing purposes, and yet at the same time economical use of water is a primary purpose.

Another phase of this consideration is the fact that the particular shower head herein is adjustable and thus will provide a spray of varying pattern so to speak both as far as size of the stream issuing therefrom and the type of stream supplied by the shower head at the outlet end thereof.

Further the invention hereof contemplates a wide range of adjustment and ability to clean the shower head with a minimum amount of operative parts, as well as thus simplifying the manufacture of the shower head by eliminating many of the parts commonly associated therewith.

Having thus set forth the general characteristics of this shower head it is a principal object of this invention to provide a shower head which is extremely efficient in operation, and provides for various types of streams and patterns of streams to issue therefrom.

It is a further object of this invention to provide a shower head in which the type of stream is adjustable within wide range and the shower head is thereby more adaptable for use by persons having different uses in mind.

Yet another object of this invention is to provide a shower head which involves the use of simple construction residing in the provision of a series of grooves in the shower head body itself, and a member movable with respect to such grooves to control the type of stream moving therefrom as well as the pattern provided by such grooves as the water leaves the shower head itself.

A still further object of the invention is to provide means for adjusting the pattern so that with the means provided a pair of stream patterns will be provided, there being a fixed portion which provides one stream in conjunction with a movable part of another member, the other of the pair of members itself providing a pattern for spray purposes.

Other and further objects of the invention will be understood from a consideration of the specification appended hereto and shown in the drawing wherein:

FIGURE 1 is a vertical sectional view showing a shower head constructed in accordance with this invention show-

2

ing the various features thereof, with the movable part of the spray regulating means in clean-out position in full lines, and in dotted line position certain adjusted intermediate position.

5 FIGURE 2 is a view similar to FIGURE 1 but fragmentarily in section in which the spray from the shower head is limited to one of the spray pattern forming devices.

FIGURE 3 is a bottom view of the invention.

10 Considering FIGURE 1, the shower head hereof is comprised of a body 1, having an inlet section 2 and an outlet section 3 therefor connected by a passageway 4.

At the inlet end of the body 1, there is provision for connecting a suitable ball joint 5 which in turn may be fastened to a shower arm by the portion 6 connected to the ball joint 5, the ball joint 5 being retained in connection with the inlet end of the body 1 by means of a nut 7 and packing 8 used to prevent leakage, all of the foregoing being somewhat conventional.

15 At the outlet end of the shower head body 1, the said end being denoted 3 as previously mentioned, there is provided a shoulder 9 and extending in diverging manner outwardly from the shoulder a series of grooves 10 which are circumferentially arranged and for purposes of relative ease of manufacture are U-shaped in section. The 20 extremities of the grooves 10 terminate at 11 as indicated.

Mounted within the body and desirably formed integrally therewith is a suitable arm 12 to which is fastened a spray regulating device generally denoted 13, 25 which device consists of a relatively long operating member consisting of a screw portion 14 at the upper end as viewed in FIGURE 1 and a handle 15 at the lower extremity.

The spray regulating device 13 further includes a disc 30 16 mounted adjacent the handle on a shoulder 17, the disc 16 being provided with a series of openings 18 therein and the disc as a whole being dish-shaped as indicated in the said FIGURE 1 disclosure.

The disc 16 is maintained in position on the shoulder 35 17 by means of a flow directing part denoted 19 which is a double truncated conical member having the cone portion 20 and the further cone portion 21, the said portions being of different angular formation as viewed in the drawing, with a common base at 22, the member thus formed being an integral part and having threads therein as will be plain from a consideration of FIGURE 2, whereby 40 the part as a whole may be used as a nut to maintain the dish-shaped disc 16 in position as previously suggested.

With the spray regulating means 13 hereinbefore described specifically, being manipulable by reason of the fact that the part 12 has threads therein, it will be apparent that the disc 16 may be moved toward and away 45 from the shoulder 9 in the outlet end 3 of the body 1. Thus the water which enters through the inlet end and ball joint 5, may be directed through the device and with the spray regulating means 13 shown in the dotted line position, water will be caused to issue through the openings 18 and likewise pass toward the periphery of the disc 16 and engage the grooves 10. It is caused to engage 50 such grooves and such openings by the truncated conical member which includes the cone elements 20 and 21 causing the water to flow as indicated, the upper conical element 20 causing the water to flow outwardly so as to engage the grooves and the conical member 21 permitting the water to move inwardly and pass out through the openings 18.

It will be also understood from the foregoing that by suitable manipulation so that the spray regulating means 13 is in its lower position as indicated in full lines in 55 FIGURE 1, the shower head as a whole may be cleansed of particles which may happen to pass thereinto and of course this will permit a very coarse stream to issue from

70

the shower head if desired to wash away such particles or impurities.

With the spray regulating part 13 in the position shown in full lines in FIGURE 2, it will be apparent that the periphery of the disc is seated against the shoulder 9 and thus water will be prevented from passing to the grooves 10. Water however will be caused to pass through the openings 18 and thus a different spray pattern will be provided, a relatively small fine pattern being the object of this condition. It will of course be readily understood that by slight manipulation of the handle 15 of the spray regulating means 13 a certain amount of water may be admitted beneath the shoulder 9 and over the periphery of the disc 16 to cause a fine spray in a pattern of greater diameter than the spray pattern provided by the openings 18 or more or less water may be caused to issue from the section involving the grooves 10 as will be understood from a consideration of the drawing herein.

It will thus be apparent that a very simple yet completely effective shower head is provided which will be susceptible of providing two different types of spray patterns at least and variations in said spray patterns according to manipulation of a spray regulating part.

I claim:

1. In a shower head of the class described, in combination, a body, an inlet and an outlet therefor of relatively small diameter, spray regulating means at said outlet including a series of grooves, a relatively small diameter disc cooperable with said grooves to vary the quantity of liquid entering said grooves to be discharged in a spray pattern from the said outlet, openings only near the center of said disc for liquid flow therethrough to form a spray pattern irrespective of the quantity of liquid entering the grooves, and a flow directing part closely adjacent the said disc arranged to direct liquid outwardly toward said grooves and inwardly toward said openings, a shoulder at the outlet, and the disc being movable to and from the same, to shut off and regulate the flow of liquid to the said grooves.

2. In a shower head of the class described, in combination, a body, an inlet and an outlet therefor of relatively small diameter, spray regulating means at said outlet including a series of grooves, a relatively small diameter disc cooperable with said grooves to vary the quantity of liquid entering said grooves to be discharged in a spray pattern from the said outlet, openings only near the center of said disc for liquid flow therethrough to form a spray pattern irrespective of the quantity of liquid entering the grooves, and a flow directing part closely adjacent the said disc arranged to direct liquid outwardly toward said grooves and inwardly toward said openings, a shoulder at the outlet, and the disc being movable to and from the same, to shut off and regulate the flow of liquid to the said grooves, said disc being mounted on a stem which is manipulable from the exterior of the body, and the flow directing part being mounted on the stem engaging the disc for movement therewith, said part having substantially the same maximum diameter as the disc.

#### References Cited in the file of this patent

##### UNITED STATES PATENTS

1,295,250	Yieser	Feb. 25, 1919
2,012,623	Boyd	Aug. 27, 1935
2,049,141	Schneider	July 28, 1936
2,069,150	Holder	Jan. 26, 1937
2,085,854	Hathaway et al.	July 6, 1937
2,118,943	Price et al.	May 31, 1938
2,222,465	Nystrom	Nov. 19, 1940
2,270,595	Lewis	Jan. 20, 1942
2,343,804	Salemme	Mar. 7, 1944
2,608,443	Hinderer	Aug. 26, 1952
2,680,649	Hansen	June 8, 1954
2,707,624	Shames et al.	May 3, 1955
2,761,662	Goodrie	Sept. 4, 1956
2,850,328	Young	Sept. 2, 1958