

(No Model.)

C. G. BURKE.

Telegraphic Repeater Sounder.

No. 243,359.

Patented June 28, 1881.

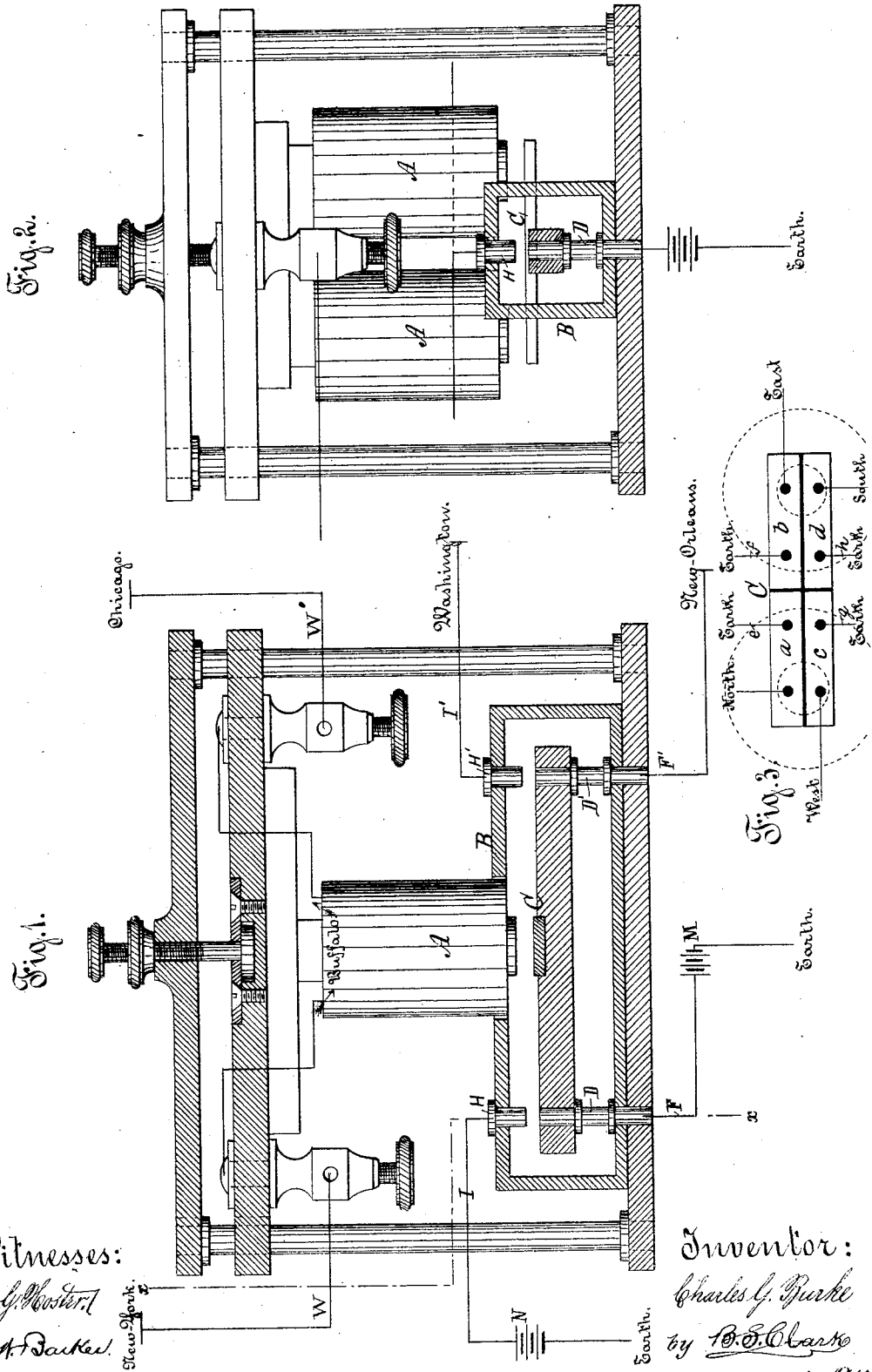

Witnesses:
Thos. M. Weston
J. A. Parker

Inventor:
Charles G. Burke
 by *B. S. Clarke*
his Atty.

UNITED STATES PATENT OFFICE.

CHARLES G. BURKE, OF NEW YORK, N. Y.

TELEGRAPHIC-REPEATER SOUNDER.

SPECIFICATION forming part of Letters Patent No. 243,359, dated June 28, 1881.

Application filed March 28, 1881. (No model.)

To all whom it may concern:

Be it known that I, CHARLES G. BURKE, of the city of New York, county and State of New York, have invented a new and valuable Improvement in Telegraphic Repeaters, of which the following is a specification.

The object of my invention is to enable the repetition in two or more directions other than that of the main line or circuit to be made of telegraphic impulses by the instrument to which the original impulse or signal has been communicated, and simultaneously with the local manifestation by sound or motion by such instrument the nature of such impulse or signal so communicated.

The following specification will more fully explain my invention, reference being had to the drawings hereto annexed and accompanying the same, in which—

Figure 1 is a side view of a telegraphic sounder arranged with my improvement, so that two repetitions of a communicated impulse will be made. Fig. 2 is an end view of the same.

A is an inverted impending electro-magnet, having the usual connections found in a telegraphic main line or circuit.

B is an armature box or frame placed beneath the magnet, in which is placed the armature C.

D and D' are stops or rests supporting armature C, when the armature is at rest or not subjected to the influence of the magnet A, and these also serve and act as receiving-posts for wires F and F'.

H and H' are also two stops passing through the top of armature-box B, which limit the upward motion of armature C, and they also serve to receive the wires I and I'.

W W' are the wires of the main line or circuit. M is a galvanic battery connected with wire F. N is also a galvanic battery connected with wire I.

It will be readily seen that the magnet A is in the main line or circuit, and that if the electric current is communicated thereto the armature C will be attracted thereby.

It will also be seen that when the armature C, which is of suitable material, rests on the stops D D' it is a connecting part of an independent circuit operated by the power of the

battery M. It will also be seen that the stops H H' at the top of the armature-box B are also separated portions of an independent circuit, and which circuit is operated by the battery N when such circuit is closed or formed by connecting the said stops H and H'.

The rest of the mechanism employed is that usually found in instruments employed in telegraphy.

The operation of my invention is as follows: To the electro-magnet A is communicated an electric impulse from the main battery. (Not shown.) The armature C is thereupon immediately attracted from the stops D and D' by such magnet A, and is met in its movement toward the said magnet and stopped by the stops H and H', manifesting locally by such movement or the sound produced thereby the impulse given, and repeating at the same time such impulse by breaking the circuit operated by the battery M and closing the circuit operated by the battery N. The duration of time or length of the continuance of the impulse so communicated and manifested will determine its character and meaning, making or defining it as a dot or a dash, and its reproduction by repetition will have and convey a corresponding and equivalent signification wherever the same is manifested by such repetition.

Thus it will be seen that by this mechanism, and which constitutes my improvement, substantially the same message may be simultaneously repeated in different directions, the number of such repetitions being only limited by the number of circuits arranged to be made or broken by the operation and movement of armature C.

The armature C may be divided, as shown in Fig. 3, into several complete and distinct parts, the whole combined forming the complete armature, it being only necessary that such parts be insulated, preventing communication with one another, and such parts so insulated may be made to make and break a corresponding number of electric circuits by their contact with or separation from the connecting-points of such circuits placed within the action of such parts by the movements of armature C. Such an armature C is divided into four distinct insulated parts, *a b c d*, as shown in Fig. 3, such parts together forming

said armature C. It (said Fig. 3) also shows four battery or electric connections, *e f g h*, and whereby four independent circuits may be simultaneously affected by the movement of armature C by the attraction of electro-magnet A, as heretofore described and explained.

The insulation of the armature shown in Fig. 3 may not ordinarily be an absolute essential element to its correct working, since the impulses communicated through the several circuits made or broken by the movement of the armature must always be the same, and therefore no confusion of meaning could arise from a commingling of the currents. Where, however, circuits differ materially in length it may be essential, and I therefore desire to provide for such a contingency by insulation. The form of the armature is unessential, except in so far as to secure a prompt and uniform movement; and I do not limit myself to the form shown. If the armature be hinged, as shown in Fig. 5 of Patent No. 240,006, issued to me April 12, 1881, and the point of the pivots of such hinge be insulated, and the bar itself, by connection, made a link of such circuit, such an armature may be used to make and break the circuits, open and closed, with the same effect and like result as the armature shown in Fig. 1.

I am aware that it is not novel to have a telegraphic instrument repeat an electric impulse in two directions at the same time, and this I do not claim, broadly; but

What I do claim, and for which I desire Letters Patent, is—

1. A telegraphic repeater or instrument consisting of an inverted impending electro-magnet with an underlying armature, such armature having a free movement upward and downward in a suitable armature-box, in combination with stops and electric circuit connecting points inserted in and affixed to said armature-box, the armature, when at rest, forming a part

or connection of one or more telegraphic circuits, and causing, by its movement upward and downward, a local manifestation of the original impulse given, and at the same time repeating, by its separation from and contact with such connecting-points, a like and simultaneous manifestation of such impulse in many directions as may be provided for, or as there are connecting circuit-points arranged in said armature-box and within the action and operation of said armature in its movements, substantially as described, and for the purpose specified.

2. An armature-box having connecting-points of two or more separate and independent electric circuits affixed therein, such points to be connected and such circuits formed and broken by an armature having a free motion upward and downward within said box, and in combination therewith, the movement of such armature being effected by an electro-magnet in combination with such armature and box, substantially as described, and for the purposes specified.

3. An armature consisting of two or more parts, each constituent part insulated and electrically distinct, the whole forming a complete armature, in combination with an armature-box having affixed therein connecting-points of distinct electric circuits corresponding with the divisions of such armature, and arranged so that the movement of such armature and its parts will close and break such electric circuits, such movement to be effected by the attractive power of an electro-magnet, in combination with such armature and armature-box and electric circuit connections, substantially as described and for the purposes specified.

CHARLES G. BURKE.

Witnesses:

THEO. G. HOSTER,
CHAS. R. CLARKE.