

April 15, 1969

R. ESCURSELL-PRAT

3,438,187

METHOD OF AUTOMATICALLY THREADING YARN FROM A BOBBIN INTO
THE RING TRAVELLER OF A CONTINUOUS RING
SPINNING MACHINE AND THE LIKE
Filed Dec. 27, 1966

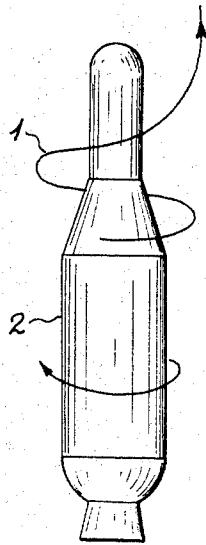

Fig. 1

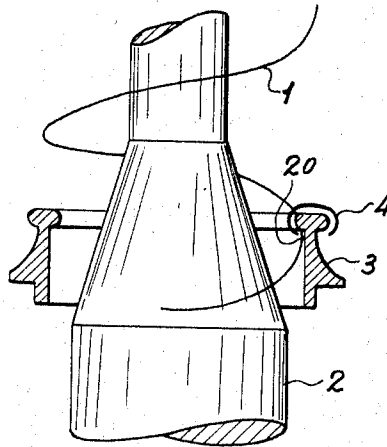

Fig. 2

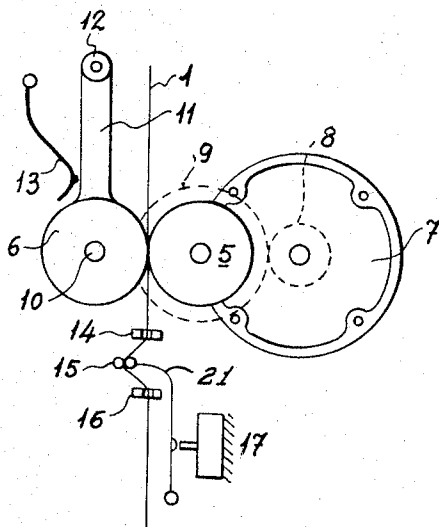

Fig. 3

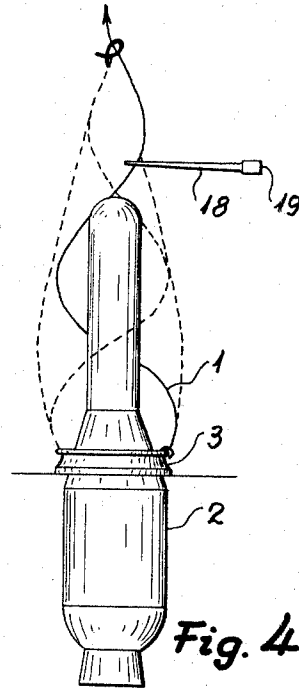

Fig. 4

INVENTOR

Roberto Escursell-Prat

BY *Cushman, Durbin & Cushman*
ATTORNEYS

1

2

3,438,187

**METHOD OF AUTOMATICALLY THREADING
YARN FROM A BOBBIN INTO THE RING
TRAVELLER OF A CONTINUOUS RING
SPINNING MACHINE AND THE LIKE**

Roberto Escursell-Prat, Ronda General Mitre 105,
Barcelona 6, Spain

Filed Dec. 27, 1966, Ser. No. 604,807

Claims priority, application Great Britain, Jan. 3, 1966,
63/66

Int. Cl. D01h 1/02, 1/40

U.S. Cl. 57—34

6 Claims

ABSTRACT OF THE DISCLOSURE

This invention relates to the threading of yarn in the ring traveller of continuous spinning machines and the like when a yarn has broken and must be repaired rapidly by increasing the size of a rotating yarn balloon to cause it to enter the traveller. Yarn breakages reduce output, and repairing the breakage makes it necessary to use unproductive manpower.

Until a few years ago the whole procedure for repairing yarn breakages involved the use of skilled labour, but a recent invention by me, which is disclosed in the specification of my U.S. Patent No. 3,128,590, has enabled yarn breakage repairs to be effected automatically with practical reliability. The apparatus disclosed in the said specification automatically performs the whole procedure for repairing a breakage, from searching for the broken yarn end wound on the bobbin to reconnecting such end to the portion projecting from the drafting rollers.

The various steps forming the automatic breakage repair method disclosed in specification No. 3,128,590 include the threading of the yarn in the ring traveller by means which are compelled to follow the reciprocating movement of the ring rail, mechanical means compelling the yarn to follow a path similar to the path along which it would be moved by a skilled machine operator to thread the yarn, the whole system being simple but requiring a relatively expansive mechanism.

The present invention solves the problem along lines completely different from prior art manual motions.

In the machine according to specification 3,128,590 the automatic operations are:

- (A) Detection of a broken yarn;
- (B) Braking of a carriage fitted with all the mechanical devices required for the yarn repair operation, and stopping the carriage in the correct position opposite the bobbin whose yarn has broken;
- (C) Braking, stopping, and then reversing the bobbin spindle;
- (D) Searching for the broken yarn end found round the bobbin cone;
- (E) Unwinding a predetermined length of yarn from the bobbin as the latter is reversed in accordance with operation (C), and raising the unwound yarn to provide a rising piece of yarn between the bobbin and the device which grips the top end of the yarn, the said device being that which performs the search in operation (D);
- (F) Threading the yarn in the ring traveller;
- (G) Threading the yarn in the yarn guide;
- (H) Severance of the excess unwound yarn, and gripping the end required for the connection;
- (J) Starting the spindle which was stopped in accordance with operation (C);
- (K) Connecting the yarn end to the roving projecting from the drafting rollers;

- (L) Checking correct start-up of spinning; and
- (M) Starting the carriage which stopped in accordance with operation (B).

The automatic operation in accordance with operation (F) changes completely in the present invention which starts from a completely different principle since threading is performed by the centrifugal force of the yarn which, when it forms a balloon because of centrifugal force between the space of the bobbin cone and the yarn guide, provides means for effecting the threading.

I have observed and studied the paths, balloons, tensions and so on of the yarn in normal spinning, that is in all the positions of the yarn guide and with various numbers of travellers and at various speeds and so on, and on the basis of this study I have concluded that, if the bobbin yarn is supported above the yarn guide and if, without passing through the traveller, the yarn and the bobbin run at the normal spinning speed, a balloon could be produced which would be wide enough at the bottom to graze in its rapid movement the inside walls of the ring and adapt itself to ring shape. If, simultaneously with the balloon being widened in this way, the turn of yarn forming the balloon were inclined sufficiently, it could readily penetrate into the traveller by way of the gap between its opening and the ring.

To make the balloon wide enough to contact the inner wall of the ring, yarn must be supplied to the balloon, and such yarn can be supplied from the yarn previously unwound in accordance with the said operation (E), or, and preferably by yarn being unwound from the bobbin, which can always provide the required quantity, the unwound turns helping to widen the balloon more rapidly.

Producing a balloon of sufficient diameter, which is one of the main features of the present invention, does not absolutely ensure threading in all cases, for the wide balloon is not always formed exactly in the inside of the ring, nor do the unwound turns incline correctly for entry into the traveller, and so means have had to be devised to ensure that these two features can be achieved satisfactorily, and this represents another facet of the invention.

In order to produce a balloon of sufficiently wide diameter to contact the inner wall of the ring in all circumstances, and to be threaded automatically once it contacts the traveller, the balloon is braked slightly externally by a distorting brake which is applied to a narrow circular strip or portion of the balloon which distorts under the pressure of the brake on which it slides. The balloon normally is completely circular in any section perpendicular to its axis, but when a short part of the balloon has the brake applied to it, the path travelled by the yarn in the braked section is not fully circular, for whenever the yarn grazes the brake, which occurs once per revolution and over a predetermined circumference arc, the circle is flattened on one side, and since this effect is repeated thousands of times a minute, and the whole balloon is in a continuous state of vibration and is distorted, with the effect that the balloon widens in its bottom part, that is, in the part inside the ring. The entire feature is adjustable, the area of the balloon on which the distorting brake acts being variable, or else the separation from the yarn carrier can be variable and more than one distorting brake can, if required, be used at various parts of the balloon.

With the threading procedure just described, the order of operations hereinbefore mentioned is the same for operations (A) to (E), but then it is better to proceed to operation (G) (that is, threading of the yarn in the yarn guide), then to operation (H) (that is, severing and gripping the yarn to piecing), and then to operation (J) (that is, starting the spindle which was stopped in accordance with operation (C)), whereafter operation (F) (that is, the operation to which the present invention re-

lates) is initiated. To perform operation (F), it is advisable for the balloon to exist in the first place, and this has been achieved by operation (J) (that is, starting the spindle) and giving the balloon sufficient diameter; as previously stated, this is done by supplying the balloon with yarn which can come from previously unwound yarn, or else it can be unwound at the moment of starting from the bobbin which is disposed higher than the yarn guide and which pulls the yarn upwards, and which will be described hereinafter, whereafter it enters the area of the balloon forming by the distorting brake which has widened that part of the balloon which is inside the ring, to ensure fully reliable threading of the yarn in the traveller.

At threading, since the yarn has been left to rotate freely, it starts to pull the so-far stationary traveller, and so there is a considerable increase in yarn tension which, as will be described hereinafter, is used as an indication that threading has been completely satisfactorily, the said operations (K), (L) and (M) then being performed to complete the required breakage repair cycle, so that the means can then move on to another bobbin spindle where the yarn is broken, the cycle then restarting.

For a better understanding of the invention, one embodiment thereof will now be described with reference to the accompanying drawings.

In the drawings:

FIG. 1 is an elevation of a bobbin and showing the balloon which the yarn forms when the bobbin rotates in the winding direction without the yarn passing through the traveller, the balloon being supplied with yarn unwinding from the top of the bobbin;

FIG. 2 is an enlarged elevation of a portion of the bobbin shown in FIG. 1 and showing the balloon grazing the inside of the ring, which is shown in section, and the ring traveller which the yarn will enter;

FIG. 3 is an elevation of a mechanism for pulling the yarn upwards to unwind the yarn from the bobbin, the mechanism being disposed on appropriate support members on the carriage referred to in operation (B), the place of installation and the form of the support being determined by the characteristics of the relevant continuous spinning machine; and

FIG. 4 is an elevation showing the action of the distorting brake in order to produce a balloon of sufficiently large diameter inside the ring whose walls the balloon grazes.

The mechanism shown in FIG. 3 comprises two rolls 5, 6; the roll 5 is rigidly secured to its spindle and can be driven by any suitable drive means which in the example shown in FIG. 3, takes the form of a motor 7 having mounted on its shaft a pinion 8 meshing with a gear wheel 9 rigidly secured to the shaft of the roll 5. The other roll 6, which can have a covering of an elastomer (rubber) to increase adhesion of the yarn 1 thereto, is freely rotatable on its spindle 10 which is disposed at the bottom end of an arm 11 pivotally mounted at its top end on a pivot 12 so as to be rockable and thus able, in co-operation with a spring 13, to keep the roll 6 in engagement with the roll 5. The rolls 5, 6 rotate to a hand such that the yarn is pulled upwards even when the bobbin is rotating to its normal hand, that is with a tendency to wind and not to unwind, and so the adhesion of the yarn between the rolls must be sufficient to prevent yarn slip, while the pull must be sufficient to reverse the direction of thread travel, and so the pulling mechanism delivers sufficient yarn for the required balloon to be found.

On its travel towards the rolls 5 and 6, the yarn 1 passes successively through three appropriately shaped yarn guides 14-16, the first or bottom yarn guide 16 and the last or top yarn guide 14 being stationary, whereas the central yarn guide 15 is movable and yields to a light pressure. The three guides 14-16 are arranged in the form of a triangle with the movable central guide 15 form-

ing the apex of the triangle and the base being provided by a line between the two stationary yarn guides 14 and 16. While the balloon is forming, the pull provides a resilient sustaining force for the movable yarn guide 15 which is maintained in the position described, but when the yarn has been threaded there is a sudden increase in tension, as previously described, and the yarn 1 then tends to be stretched into a straight line and greater pressure is applied to the central yarn guide 15 which then yields resiliently and, in so doing, closes, through an arm 21, the contact of a sensitive microswitch 17 which initiates cessation of the threading operation, the same now being completed, and then initiates the performance of the operation (K), (L) and (M) hereinbefore described.

The means referred to herein as a distorting brake serves to compel the balloon to widen out accurately inside the ring, and also to ensure that the turns or, more accurately, the path described by the balloon yarn 1 is sufficiently inclined to enter readily into the gap between the traveller and the ring, at the position indicated by the reference numeral 20 in FIG. 2. Basically, each distorting brake comprises one or more members 18 each pivotally mounted at 19 to a part of the apparatus, in order that they may, at an appropriate time, be introduced, by operating means of the apparatus, into the space occupied by the balloon to provide the balloon-distorting effect previously described, the balloon-distorting effect being greater if the distorting brake is vibratory, that is if vibration is induced by the action of the moving yarn so that the brake element enters the balloon area many times per minute to produce the distortion of the required amplitude inside the ring and the appropriate inclination of the turns so that the turns escape from the pulling action previously mentioned. The length, nature of the surface in contact with the balloon yarn, and other features of the distorting brake are arranged to suit the nature of the yarn material being worked and the dimensions of the continuous spinning machine on which the apparatus is mounted.

Briefly, the operation enabled by use of the method according to the present invention is as follows:

When the bobbin 2 rotates freely after performance of operations (A)-(E), (G) and (H), the yarn 1 (FIGS. 1, 2 and 4) starts to form a balloon because of the centrifugal force experienced by the yarn 1 as a result of bobbin speed. The diameter of the balloon increases as further yarn is supplied from the bobbin 2 because of the pulling or unwinding action of the rolls 5, 6 (FIG. 3) which starts to be driven by the motor 7 simultaneously with the bobbin 2. Because of its own rotation, and since the yarn 1 is bearing at the confluency of tangents of the rolls 5, 6, it penetrates and is gripped between the rolls, unwinding from the bobbin because of the rotatory movement of the rolls; simultaneously, the distorting brake 18 (FIG. 4) enters into the balloon area and produces a distortion and a constant vibration of the balloon in order to widen the lower part of the balloon in the zone bounded by the ring 3 (FIGS. 2 and 4) so that the yarn grazes the inside surface of the ring 3, and because of its inclination, enters between the traveller 4 and the ring 3 to be threaded in the traveller 4. Thereupon, the tension of the yarn 1 increases sufficiently for the moving yarn guide 15 to move towards the line of the stationary yarn guides 14 and 16 and thus operate the microswitch 17 to initiate termination of the threading operation and the succeeding operations.

The pulling system which unwinds the bobbin yarn may run at a high constant speed, or variable intermittent speed, and the distorting brake, of which there can be more than one, can be disposed at variable heights of the balloon and have an area of varying length and width in contact with the balloon; also, the pulling mechanism and the distorting brake may be embodied, as regards shape, dimensions and materials, appropriately to the quality and size of the yarns to be joined.

What I claim is:

1. A method of automatically re-threading yarn wound

5

around a bobbin into a ring traveller of a continuous ring spinning machine comprising withdrawing yarn upwardly from the bobbin to a point spaced generally axially thereabove during rotation of the bobbin in a forward direction to form a large diameter yarn balloon about the bobbin, and contacting the rotating yarn balloon with means whereby the diameter of the lower part of the rotating yarn balloon in the zone bounded by said ring traveller is increased so that the rotating yarn balloon grazes the inside surface of said ring and enters the space between said ring traveller and said ring.

2. Apparatus for automatically re-threading yarn from a bobbin into the ring traveller of a continuous ring spinning machine comprising means for unwinding yarn in sufficient length from said bobbin as the bobbin is rotated to form and maintain a rotating yarn balloon and contact means for engaging the rotating yarn balloon whereby the diameter of the lower part of the yarn balloon adjacent the ring traveller is increased causing the rotating yarn balloon to graze the inner wall surface of said ring and to be automatically threaded in said ring traveller.

3. The apparatus of claim 2 wherein said means for unwinding yarn from said rotating bobbin comprises in combination a driven roll the peripheral surface of which is in frictional engagement with the peripheral surface of a freely rotatable roll and between which rolls said yarn is passed and unwound from said bobbin.

4. The apparatus of claim 3 wherein the peripheral surface of one of said rolls is provided with an elastomeric material.

5. The apparatus of claim 3 including yarn guide means

6

disposed between said bobbin and said rolls comprising a pair of spaced aligned stationary yarn guides and an intermediate movable yarn guide laterally offset from said stationary yarn guides and means operative in response to the movement of said movable yarn guide into alignment with said stationary yarn guides to discontinue the automatic threading operation.

6. The apparatus of claim 1 wherein said contacting means for engaging the rotating yarn balloon comprises at least one braking device pivotally mounted on said spinning machine and extending sufficiently into the yarn balloon area for contact therewith.

References Cited

UNITED STATES PATENTS

2,449,742	9/1948	Foster et al.	57—57
3,128,590	4/1964	Escursell-Prat	57—34

FOREIGN PATENTS

553,305	12/1956	Belgium.
---------	---------	----------

OTHER REFERENCES

German printed application 1,069,042, Rossi, November 1959, 57—34.

JOHN PETRAKES, *Primary Examiner.*

U.S. Cl. X.R.

57—54, 156