

(19) World Intellectual Property Organization
International Bureau



(43) International Publication Date
7 September 2007 (07.09.2007)

PCT

(10) International Publication Number
WO 2007/100447 A2

(51) International Patent Classification: Not classified

(21) International Application Number:
PCT/US2007/003012

(22) International Filing Date: 5 February 2007 (05.02.2007)

(25) Filing Language: English

(26) Publication Language: English

(30) Priority Data:
60/776,200 24 February 2006 (24.02.2006) US
11/653,912 17 January 2007 (17.01.2007) US

(71) Applicant (for all designated States except US): **LOCKHEED MARTIN CORPORATION** [US/US]; 6801 Rockledge Drive, Bethesda, MD 20817 (US).

(72) Inventors; and

(75) Inventors/Applicants (for US only): **HENTOSH, David, J.** [US/US]; 859 Manor Gate, Yardley, PA 19067 (US). **EDRIDGE, Michael** [US/US]; 1201 Penn Valley Terrace, Yardley, PA 19067 (US).

(74) Agent: **ITRI, Mark, J.**; McDermott Will & Emery LLP, 18191 Von Karman, Suite 500, Irvine, CA 92612 (US).

(81) Designated States (unless otherwise indicated, for every kind of national protection available): AE, AG, AL, AM, AT, AU, AZ, BA, BB, BG, BR, BW, BY, BZ, CA, CH, CN, CO, CR, CU, CZ, DE, DK, DM, DZ, EC, EE, EG, ES, FI, GB, GD, GE, GH, GM, GT, HN, HR, HU, ID, IL, IN, IS, JP, KE, KG, KM, KN, KP, KR, KZ, LA, LC, LK, LR, LS, LT, LU, LV, LY, MA, MD, MG, MK, MN, MW, MX, MY, MZ, NA, NG, NI, NO, NZ, OM, PG, PH, PL, PT, RO, RS, RU, SC, SD, SE, SG, SK, SL, SM, SV, SY, TJ, TM, TN, TR, TT, TZ, UA, UG, US, UZ, VC, VN, ZA, ZM, ZW.

(84) Designated States (unless otherwise indicated, for every kind of regional protection available): ARIPO (BW, GH, GM, KE, LS, MW, MZ, NA, SD, SL, SZ, TZ, UG, ZM, ZW), Eurasian (AM, AZ, BY, KG, KZ, MD, RU, TJ, TM), European (AT, BE, BG, CH, CY, CZ, DE, DK, EE, ES, FI, FR, GB, GR, HU, IE, IS, IT, LT, LU, LV, MC, NL, PL, PT, RO, SE, SI, SK, TR), OAPI (BF, BJ, CF, CG, CI, CM, GA, GN, GQ, GW, ML, MR, NE, SN, TD, TG).

Published:
— without international search report and to be republished upon receipt of that report

For two-letter codes and other abbreviations, refer to the "Guidance Notes on Codes and Abbreviations" appearing at the beginning of each regular issue of the PCT Gazette.

(54) Title: SYSTEM OF STOWING AND DEPLOYING MULTIPLE PHASED ARRAYS OR COMBINATIONS OF ARRAYS AND REFLECTORS

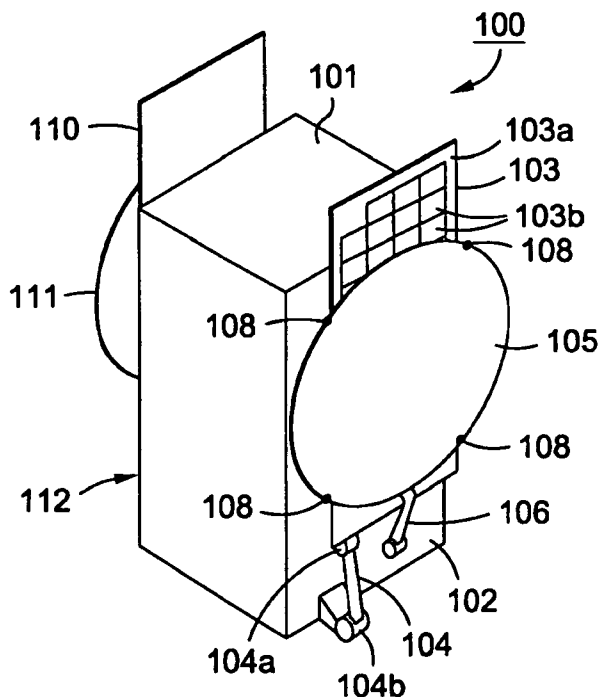

(57) Abstract: A spacecraft is provided that includes a spacecraft body, a phased array coupled to a side of the spacecraft body by a first deployment couple, and a reflector coupled to the side of the spacecraft body by a second deployment couple. The first and second deployment couples are configured to permit stowing the reflector and the phased array parallel to the side of the spacecraft body. The reflector and the phased array share a common launch restraint mounting point on the side of the spacecraft body. A spacecraft is also provided that includes a spacecraft body, a mounting platform coupled to a side of the spacecraft body by a deployment couple, and a plurality of phased array assemblies. Each phased array assembly has a face with elements, and is coupled to the mounting platform by a gimbal. The deployment couple and the gimbals are configured to permit stowing the phased array assemblies parallel to the side of the spacecraft body and with the face of each phased array assembly oriented in a first direction. The phased array assemblies share a common launch restraint mounting point on the side of the spacecraft body.

WO 2007/100447 A2

**SYSTEM OF STOWING AND DEPLOYING MULTIPLE PHASED ARRAYS
OR COMBINATIONS OF ARRAYS AND REFLECTORS**

CROSS-REFERENCE TO RELATED APPLICATION

[0001] The present application claims the benefit of priority under 35 U.S.C. §119 from U.S. Provisional Patent Application Serial No. 60/776,200 entitled "SYSTEM OF STOWING AND DEPLOYING MULTIPLE PHASED ARRAYS OR COMBINATIONS OF ARRAYS AND REFLECTORS," filed on February 24, 2006, the disclosure of which is hereby incorporated by reference in its entirety for all purposes.

STATEMENT REGARDING FEDERALLY SPONSORED RESEARCH OR DEVELOPMENT

[0002] Not applicable.

FIELD OF THE INVENTION

[0003] The present invention generally relates to the stowage and deployment of spacecraft elements and, in particular, relates to the stowage and deployment of multiple phased arrays or combinations of phased arrays and reflectors.

BACKGROUND OF THE INVENTION

[0004] One of the problems of stowing and deploying both phased arrays and antenna reflectors on the same spacecraft is the mass imbalance created by stowing an array on one side and a reflector on the other. If one side of a spacecraft contains reflectors and the other side phased arrays, the side-to-side center of gravity offset from the spacecraft center axis may lie well outside the limits prescribed by launch vehicle manuals. On-orbit control of the spacecraft may also become troublesome.

[0005] Additional problems are encountered when multiple phased arrays or phased array assemblies are provided on a single spacecraft. The mass and size of the spacecraft makes it increasingly difficult to support, deploy, and steer. Moreover, in systems in which each phased array or phased array assembly is provided with its own launch restraint system or tie downs, the increased mass of the launch restraints and launch restraint severing systems will further impact the useful payload of the spacecraft.

SUMMARY OF THE INVENTION

[0006] The present invention solves the foregoing problems by providing a stowage system that allows the packaging of one or more phased arrays and reflectors on the East and West sides of a spacecraft in order to distribute the mass of the spacecraft in a more symmetrical manner. This stowage system more efficiently uses the available volume in a launch vehicle and allows phased arrays and reflectors to have their own deployment, retention, and pointing systems, while requiring fewer common launch restraint systems.

[0007] According to one embodiment of the present invention, a spacecraft comprises a spacecraft body, a first phased array coupled to a first side of the spacecraft body, a first reflector coupled to the first side of the spacecraft body and a first deployment couple disposed between the first phased array and the first side of the spacecraft body, coupled to the first phased array and the first side of the spacecraft body, and configured to permit stowing the first phased array parallel to the first side of the spacecraft body. The spacecraft further comprises a second deployment couple disposed between the first reflector and the first side of the spacecraft body, coupled to the first reflector and the first side of the spacecraft body, and configured to permit stowing the first reflector parallel to the first side of the spacecraft body. The spacecraft further comprises a first common launch restraint system configured to secure the first phased array and the first reflector to the first side of the spacecraft body using at least one common launch restraint mounting point.

[0008] According to another embodiment of the present invention, a spacecraft comprises a spacecraft body, a first mounting platform coupled to a first side of the spacecraft body, a first deployment couple disposed between the first mounting platform and the first side of the spacecraft body and coupled to the first mounting platform and the first side of the spacecraft

body, and a first plurality of phased array assemblies. Each of the first plurality of phased array assemblies has a face with a plurality of elements, and each of the first plurality of phased array assemblies is coupled to the first mounting platform by a gimbal. The spacecraft further comprises a first common launch restraint system configured to secure the first plurality of phased array assemblies to the first side of the spacecraft body using at least one common launch restraint mounting point. The first deployment couple and the first plurality of gimbals are configured to permit stowing the first plurality of phased array assemblies parallel to the first side of the spacecraft body and with the face of each of the first plurality of phased array assemblies oriented in a first direction.

[0009] It is to be understood that both the foregoing summary of the invention and the following detailed description are exemplary and explanatory and are intended to provide further explanation of the invention as claimed.

BRIEF DESCRIPTION OF THE DRAWINGS

[0010] The accompanying drawings, which are included to provide further understanding of the invention and are incorporated in and constitute a part of this specification, illustrate embodiments of the invention and together with the description serve to explain the principles of the invention. In the drawings:

[0011] Figures 1A and 1B illustrate stowed and deployed states of a spacecraft according to one embodiment of the present invention;

[0012] Figures 2A to 2D illustrate various states of stowage and deployment of a spacecraft according to one embodiment of the present invention; and

[0013] Figures 3A to 3C illustrate stowed and deployed states of a spacecraft according to one embodiment of the present invention.

DETAILED DESCRIPTION OF THE INVENTION

[0014] In the following detailed description, numerous specific details are set forth to provide a full understanding of the present invention. It will be apparent, however, to one ordinarily skilled in the art that the present invention may be practiced without some of these

specific details. In other instances, well-known structures and techniques have not been shown in detail to avoid unnecessarily obscuring the present invention.

[0015] Deployable phased arrays and launch restraint subsystems are designed to increase the flexibility, configurability and capability of modern satellites. In this regard, the stowed state is a state in which launch restraints are restraining the phased arrays or phased array assemblies in place for transport, and the deployment couples are in a volume-minimizing, retracted position. The deployed state is a state in which the launch restraints have been removed, and the phased arrays or phased array assemblies have been moved from the stowed position and oriented in their operational locations by fully articulating the deployment couples. A transitory deploying state in between the stowed state and the deployed state is also contemplated, but illustration of this state is not necessary for the purpose of understanding the features of the present invention.

[0016] Figure 1A illustrates a spacecraft according to one embodiment of the present invention, in which a reflector and a phased array are stowed with a common launch restraint mounting point on the same side of the spacecraft. Spacecraft 100 includes spacecraft body 101, which has a side 102. Coupled parallel to side 102 of spacecraft body 101 (*i.e.*, in a stowed position) by a deployment couple 104 is a phased array 103. Phased array 103 has a face 103a on which are disposed a number of elements 103b. Face 103a is oriented facing away from side 102, to protect elements 103b from being damaged during launch by side 102. Also coupled parallel to side 102 of spacecraft body 101 by another deployment couple 106 is a reflector 105. In the present exemplary embodiment, deployment couple 104 includes both a 1-axis hinge 104b and a 2-axis primary deployment gimbal 104a, while deployment couple 106 includes a 2-axis gimbal 106a. Four launch restraint locations 108 are provided in reflector 105 for securing reflector to side 102 of spacecraft body 101 with a launch restraint system (not illustrated). Spacecraft 100 further includes another side 112 opposite side 102, to which are coupled another phased array 110 and another reflector 111. Phased array 110 and reflector 111 are coupled to side 112 in a similar manner to that in which phased array 103 and reflector 105 are coupled to side 102.

[0017] Turning to Figure 1B, spacecraft 100 is illustrated with reflector 105 and phased array 103 in a deployed state. As can be seen with reference to Figure 1B, 2-axis primary deployment gimbal 104a which permits phased array 103 to rotate about an axis 104b of deployment couple 104. Primary deployment gimbal 104a permits phased array 103 to deploy with its face 103a and elements 103b pointing up, by rotating phased array 103 through 180° around axis 104b. As can also be seen with reference to Figure 1B, deployment couple 106 includes a 2-axis gimbal 106a configured to permit reflector 105 to be deployed in the same plane as phased array 103, but with a different axis of orientation (e.g., by rotating reflector 105 around axis 106b).

[0018] In Figure 1B, the common launch restraint mounting points 107 which reflector 105 and phased array 103 share can be seen on side 102 of spacecraft body 101. Also visible are the launch restraint locations 109 provided in phased array 103 for securing phased array 103 to side 102 of spacecraft body 101 using a launch restraint system. Using the enhanced antenna stowage and deployment system according to the embodiment of present invention illustrated in Figures 1A and 1B, the co-location and consolidation of launch restraints reduces the weight and volume of spacecraft 100 by reducing the number of necessary launch restraints and launch restraint severing mechanisms, thereby increasing overall mission capabilities.

[0019] While in the foregoing exemplary embodiment, reflector 105 has been shown stowed on top of phased array 103, the scope of the present invention is not limited to such an arrangement. Rather, as will be apparent to one of skill in the art, the present invention has application to arrangements in which a phased array is stowed on top of a reflector, or arrangements in which reflectors and phased arrays are stacked in any order.

[0020] Similarly, while the foregoing exemplary embodiment, exactly four common launch restraint mounting points 107 have been illustrated on side 102 of spacecraft body 101, the scope of the present invention is not limited to such an arrangement. Rather, as will be apparent to one of skill in the art, the present invention has application to arrangements in which any number of common launch restraints greater than or equal to one are shared on a side of a spacecraft body.

[0021] Since the purpose of deployment couples 104 and 106 is to deploy the phased array and reflector, respectively, the appropriate size, tolerances, arrangement, type and design of deployment couples 104 and 106 depends on several factors, including aperture size, number and type of phased array elements or reflectors on each assembly, spacecraft size, type, design, or material, or any number of other factors. As such, in certain simple arrangements, deployment couple 104 may include only a single 1-axis separating hinge, in order to effectively separate and deploy phased array 103 using a single 1-axis motion. In other arrangements, deployment couple 104 may include a single 2-axis primary deployment gimbal only, deploying and orienting phased array 103 in a more complex 2-axis motion.

[0022] Similarly, in further arrangements, deployment couples such as couples 104 and 106 may include a combination of a 1-axis separating hinge together with a 2-axis primary deployment gimbal. Using such a deployment couple with both a separating hinge and a primary deployment gimbal, the antenna stowage and deployment system according to one embodiment of the present invention effectuates an initial separation motion (using the 1-axis separating hinge) followed by a deployment maneuver once the phased arrays and/or reflectors have been separated (using the 2-axis primary deployment gimbal). As will be apparent to one of skill in the art, the scope of the present invention is not limited to the particular arrangement of hinges and gimbals described herein, but rather has application to stowage and deployment systems with any combination of hinges, gimbals, or other joints or turning points known to those of skill in the art.

[0023] Turning to Figure 2A, another spacecraft is illustrated in accordance with another embodiment of the present invention, in which two phased array assemblies are coupled to the same side of a spacecraft body. Spacecraft 200 includes spacecraft body 201 with a side 202. Coupled parallel to side 202 (*i.e.*, in the stowed position) of spacecraft body 202 by a deployment couple 204 is a phased array 203, which is made up of phased array assemblies 203a and 203b. Deployment couple 204 includes 1-axis separating hinge 204b for separating phased array 203 from spacecraft body 201. Coupled to deployment couple 204 is a mounting platform 205, to which phased array assemblies 203a and 203b are coupled by 2-axis primary deployment gimbals 205a and 205b, respectively. Assembly 203b has a face 203c on which are disposed a number of elements 203d. Face 203c is oriented facing away

from side 202, to keep elements 203d from rubbing against the elements (not shown) of assembly 203a. Four launch restraint locations 209 are provided in reflector assembly 203b (and four in assembly 203a, not all of which are visible in this Figure) for mounting phased array 203 to side 202 of spacecraft body 201, as is illustrated in greater detail with respect to Figure 2C, below.

[0024] Turning to Figure 2B, spacecraft 200 is seen in a first phase of deployment, in which deployment couple 204 has pivoted mounting platform 205 and phased array 203 away from side 202 of spacecraft body 201. In this view, the common launch restraint mounting points 207 which assemblies 203a and 203b share can be seen on side 202 of spacecraft body 201. Also visible are additional launch restraint locations 209 in assembly 203a, the back side of which (*i.e.*, the side without elements) is visible at this phase.

[0025] Turning next to Figure 2C, spacecraft 200 is seen in another phase of deployment, in which primary deployment gimbals 205a and 205b have rotated assemblies 203a and 203b, respectively, around axes 205c and 205d (which are parallel to an axis of deployment couple 204) through an angle of 180°. In the present exemplary embodiment, assembly 203a has been rotated 180° counter-clockwise, while assembly 203b has been rotated 180° in a clockwise direction. Visible in this Figure is the face 203e of assembly 203a, on which are disposed elements 203f. As can be seen with reference to Figures 2A to 2C, deployment couple 204, mounting platform 205 and primary deployment gimbals 205a and 205b permit phased array assemblies 203a and 203b to be stored with their faces 203e and 203c commonly oriented (*e.g.*, in the present example, oriented facing away from side 202 of spacecraft body 201).

[0026] Figure 2D illustrates spacecraft 200 enjoying yet another advantage of a mounting system according to one embodiment of the present invention. As can be seen with reference to Figure 2D, mounting platform 205 and primary deployment gimbals 205a and 205b are configured to permit phased array assemblies 203a and 203b to lie in a single plane and be rotated to have different axes of orientation, in a manner similar to that illustrated in Figure 1B with respect to reflector 105 and phased array 103. 2-axis primary deployment gimbal 205a is configured to rotate phased array assembly 203a over an angle of Φ_2 such that

the axis of orientation of phased array assembly 203a changes from axis 205c to axis 205e. Similarly, 2-axis primary deployment gimbal 205b is configured to rotate phased array assembly 203b over an angle of Φ_1 such that the axis of orientation of phased array assembly 203b changes from axis 205d to axis 205f. In this manner, phased array assemblies 203a and 203b can be separated upon deployment and, when provided with independent pointing systems (*e.g.*, motor assemblies or other actuators for moving phased array assemblies with respect to mounting platform 205), phased array assemblies 203a and 203b can be steered separately.

[0027] While the foregoing exemplary embodiment has been described with reference to the faces of multiple phased array assemblies all pointing away from the side of a spacecraft body when stowed, the scope of the present invention is not limited to such an arrangement. Rather, as will be apparent to one of skill in the art, the present invention has application to arrangements in which the faces of multiple phased array assemblies all point towards the side of a spacecraft body when stowed, or arrangements in which the faces of multiple phased array assemblies point in different directions when stowed.

[0028] Similarly, while the foregoing exemplary embodiments have been described with reference to phased arrays and phased array assemblies having only one face with elements, the scope of the present invention is not limited to such an arrangement. Rather, as will be apparent to one of skill in the art, the present invention has application to arrangements in which phased arrays are provided with elements on more than one face.

[0029] Moreover, while the foregoing exemplary embodiment has been described with reference to a single phased arrays mounted to a single side of a spacecraft body, the scope of the present invention is not limited to such an arrangement. Rather, as will be apparent to one of skill in the art, the present invention has application to arrangements in which multiple phased arrays are provided one more than one side of a spacecraft body.

[0030] Figures 3A to 3C illustrate a spacecraft in accordance with another embodiment of the present invention, in which three phased array assemblies are coupled to the same side of a spacecraft body by a single deployment couple and a single mounting platform. Turning to Figure 3A, spacecraft 300 includes spacecraft body 301 with a side 302. Coupled to side 302

(i.e., here illustrated in a partially deployed position) of spacecraft body 302 by a deployment couple 304 is a phased array 3, which is made up of three phased array assemblies. Attached to deployment couple 304 is a mounting platform 305, to which the three phased array assemblies are coupled by 2-axis primary deployment gimbals 305a, 305b and 305c.

[0031] Turning to Figure 3B, spacecraft 300 is illustrated with phased array 303 in the next step of deployment, in which phased array assemblies 303a and 303b have been rotated by gimbals 305a and 305b, respectively, through 180° about axes 304a and 304b (which are parallel to an axis of deployment couple 304). In Figure 3C, spacecraft 300 is illustrated with phased array 300 in a fully-deployed state, with phased array assembly 303c having been rotated through 180° about axis 304c, which is parallel to an axis of deployment couple 304 (e.g., an axis defined at least in part by a direction in which a portion of deployment couple 304 is pointing).

[0032] While the present invention has been particularly described with reference to the various figures and embodiments, it should be understood that these are for illustration purposes only and should not be taken as limiting the scope of the invention. There may be many other ways to implement the invention. Many changes and modifications may be made to the invention, by one having ordinary skill in the art, without departing from the spirit and scope of the invention.

WHAT IS CLAIMED IS:

1. A spacecraft comprising:
 - a spacecraft body;
 - a first phased array coupled to a first side of the spacecraft body;
 - a first reflector coupled to the first side of the spacecraft body;
 - a first deployment couple disposed between the first phased array and the first side of the spacecraft body and coupled to the first phased array and the first side of the spacecraft body, the first deployment couple configured to permit stowing the first phased array parallel to the first side of the spacecraft body;
 - a second deployment couple disposed between the first reflector and the first side of the spacecraft body and coupled to the first reflector and the first side of the spacecraft body, the second deployment couple configured to permit stowing the first reflector parallel to the first side of the spacecraft body; and
 - a first common launch restraint system configured to secure the first phased array and the first reflector to the first side of the spacecraft body using at least one common launch restraint mounting point.
2. The spacecraft of claim 1, wherein the first deployment couple and the second deployment couple are configured to permit stowing the first reflector on top of the first phased array.
3. The spacecraft of claim 1, wherein the first phased array and the first reflector each include one or more launch restraint locations for securing the first phased array and the first reflector to the common launch restraint mounting point.

4. The spacecraft of claim 1, wherein the first phased array has a face with a plurality of elements, and wherein the first deployment couple includes a gimbal configured to permit stowing the first phased array parallel to the first side of the spacecraft body and with the face of the first phased array oriented away from the first side of the spacecraft body.

5. The spacecraft of claim 4, wherein the gimbal is configured to permit rotating the first phased array around an axis of the first deployment couple through an angle of at least 180°.

6. The spacecraft of claim 1, wherein the first phased array comprises a plurality of phased array assemblies, wherein each of the plurality of phased array assemblies are coupled to a mounting platform by a gimbal, and wherein the mounting platform is coupled to the first deployment couple.

7. The spacecraft of claim 6, wherein each of the plurality of phased array assemblies has a face with a plurality of elements, and wherein the first deployment couple and the gimbals of the plurality of phased array assemblies are configured to permit stowing the plurality of phased array assemblies parallel to the first side of the spacecraft body and with the face of each of the plurality of phased array assemblies oriented in a first direction.

8. The spacecraft of claim 6, wherein at least one of the plurality of gimbals is configured to permit rotating an associated phased array assembly around an axis parallel to an axis of the first deployment couple through an angle of at least 180°.

9. The spacecraft of claim 6, wherein at least one of the plurality of gimbals is a 2-axis gimbal configured to permit deploying an associated phased array assembly in a same plane as another one of the plurality of phased array assemblies and with a different axis of orientation as the other one of the plurality of phased array assemblies.

10. The spacecraft of claim 1, wherein the second deployment couple includes a 2-axis gimbal configured to permit deploying the first reflector in a same plane as the first phased array and with a different axis of orientation as the first phased array.

11. The spacecraft of claim 1, further comprising:

a second phased array coupled to a second side of the spacecraft body;

a second reflector coupled to the second side of the spacecraft body;

a third deployment couple disposed between the second phased array and the second side of the spacecraft body and coupled to the second phased array and the second side of the spacecraft body, the third deployment couple configured to permit stowing the second phased array parallel to the second side of the spacecraft body;

a fourth deployment couple disposed between the second reflector and the second side of the spacecraft body and coupled to the second reflector and the second side of the spacecraft body, the fourth deployment couple configured to permit stowing the second reflector parallel to the second side of the spacecraft body; and

a second common launch restraint system configured to secure the second phased array and the second reflector to the second side of the spacecraft body using a second at least one common launch restraint mounting point.

12. The spacecraft of claim 11, wherein the first side of the spacecraft body and the second side of the spacecraft body are opposite one another.

13. A spacecraft comprising:

a spacecraft body;

a first mounting platform coupled to a first side of the spacecraft body;

a first deployment couple disposed between the first mounting platform and the first side of the spacecraft body and coupled to the first mounting platform and the first side of the spacecraft body;

a first plurality of phased array assemblies, each of the first plurality of phased array assemblies having a face with a plurality of elements, each of the first plurality of phased array assemblies being coupled to the first mounting platform by a gimbal; and

a first common launch restraint system configured to secure the first plurality of phased array assemblies to the first side of the spacecraft body using at least one common launch restraint mounting point,

wherein the first deployment couple and the first plurality of gimbals are configured to permit stowing the first plurality of phased array assemblies parallel to the first side of the spacecraft body and with the face of each of the first plurality of phased array assemblies oriented in a first direction.

14. The spacecraft of claim 13, wherein at least one of the plurality of gimbals is configured to permit rotating an associated phased array assembly around an axis parallel to an axis of the first deployment couple through an angle of at least 180°.

15. The spacecraft of claim 13, wherein at least one of the plurality of gimbals is a 2-axis gimbal configured to permit deploying an associated phased array assembly in a same plane as another one of the plurality of phased array assemblies and with a different axis of orientation as the other one of the plurality of phased array assemblies.

16. The spacecraft of claim 15, further comprising a plurality of motor assemblies corresponding to the plurality of phased array assemblies, each motor assembly being configured to independently steer a corresponding phased array assembly.

17. The spacecraft of claim 13, further comprising:
a second mounting platform coupled to a second side of the spacecraft body;
a second deployment couple disposed between the second mounting platform and the second side of the spacecraft body and coupled to the second mounting platform and the second side of the spacecraft body;

a second plurality of phased array assemblies, each of the second plurality of phased array assemblies having a face with a plurality of elements, each of the second plurality of phased array assemblies being coupled to the second mounting platform by a gimbal; and

a second common launch restraint system configured to secure the second plurality of phased array assemblies to the second side of the spacecraft body using at least one common launch restraint mounting point,

wherein the second deployment couple and the second plurality of gimbals are configured to permit stowing the second plurality of phased array assemblies parallel to the second side of the spacecraft body and with the face of each of the second plurality of phased array assemblies oriented in a second direction.

18. The spacecraft of claim 17, wherein the first side of the spacecraft body and the second side of the spacecraft body are opposite one another.

19. The spacecraft of claim 13, wherein each of the first plurality of phased array assemblies includes one or more launch restraint locations for mounting the first plurality of phased array assemblies to the common launch restraint mounting point with a launch restraint system.

20. The spacecraft of claim 13, further comprising a reflector coupled to the first side of the spacecraft body by a second deployment couple.

21. The spacecraft of claim 20, wherein the reflector shares the first common launch restraint mounting point with the first plurality of phased array assemblies.

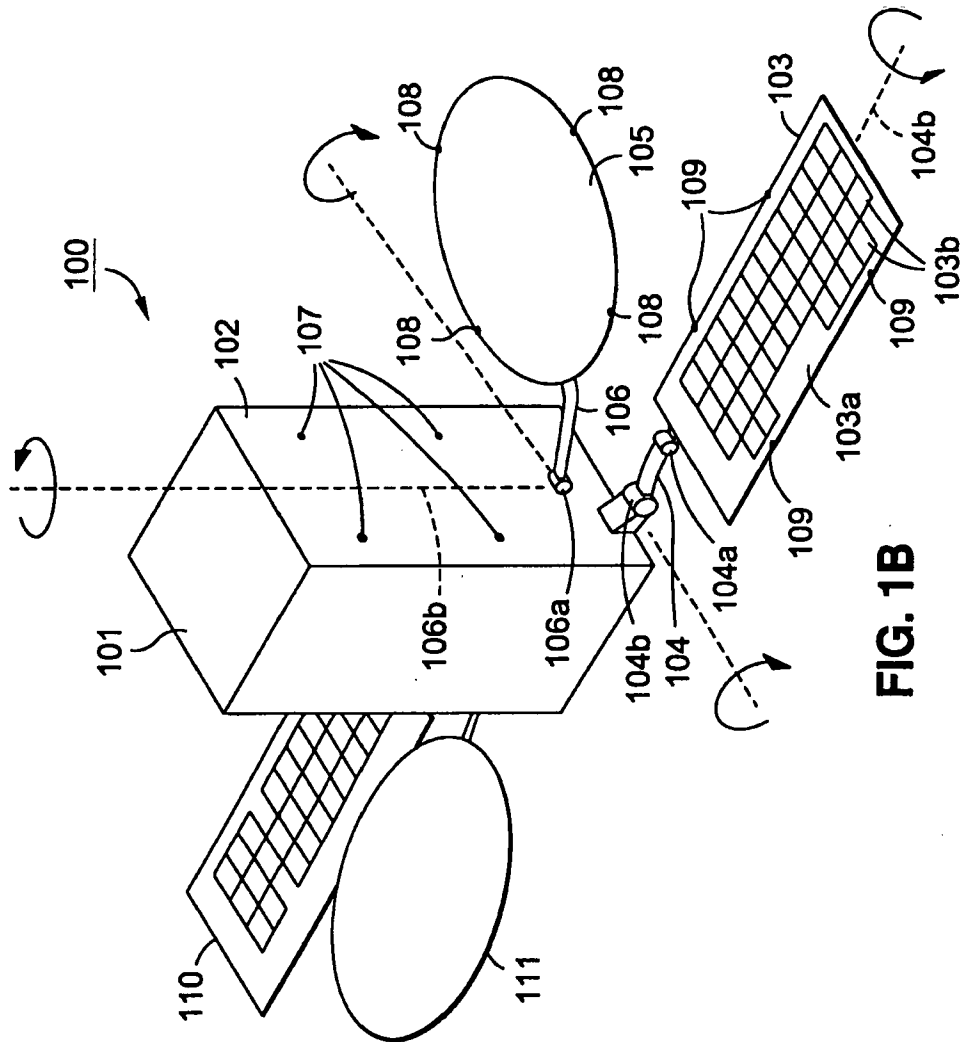

FIG. 1B

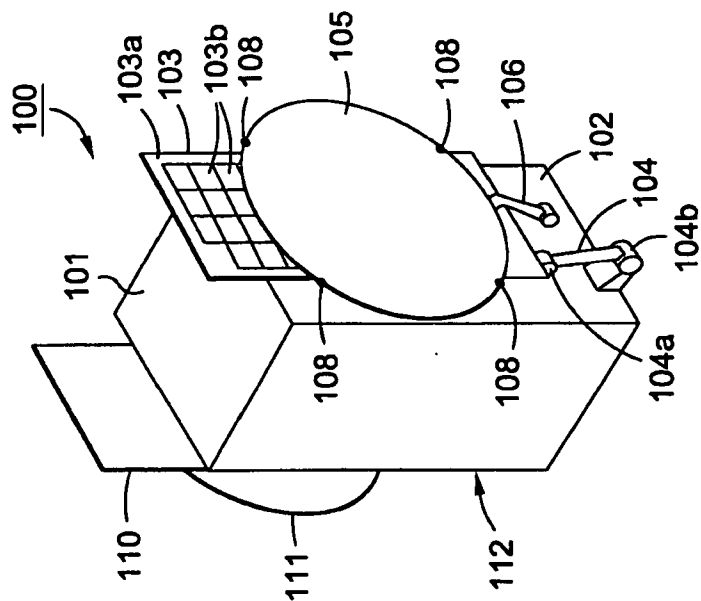

FIG. 1A

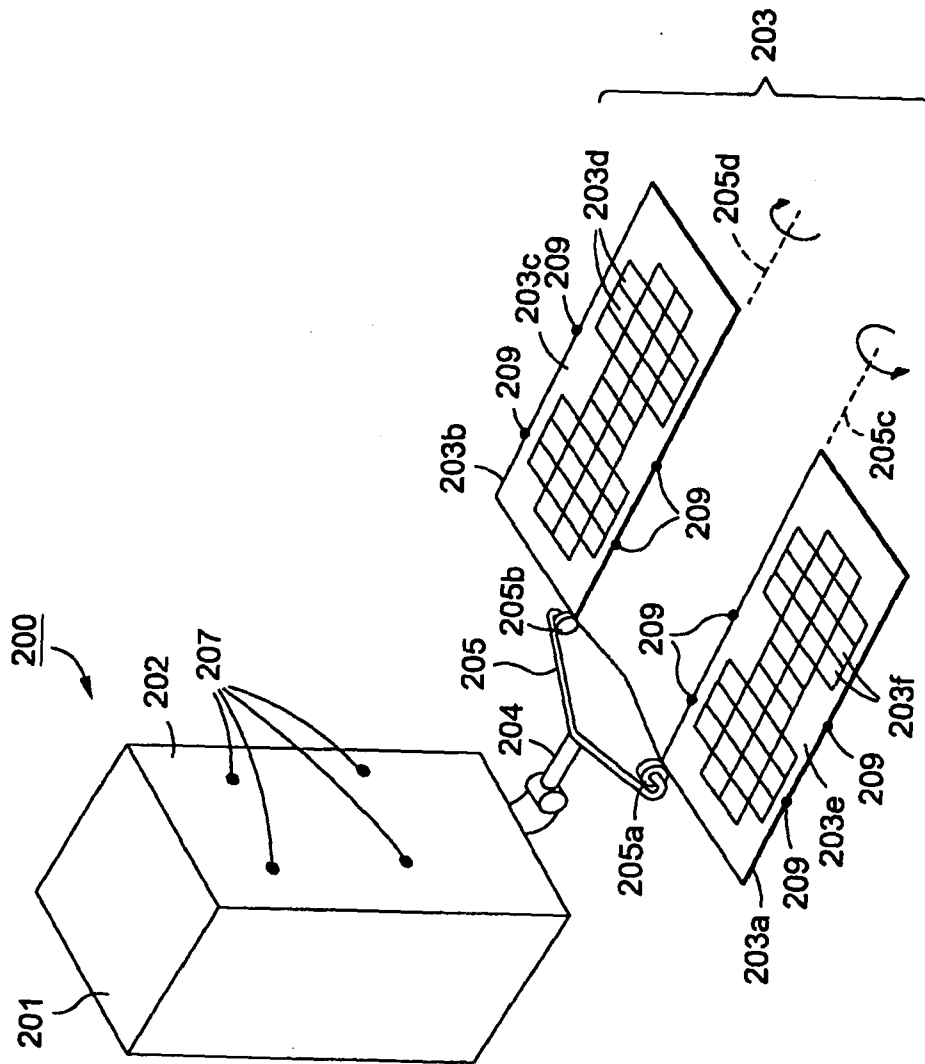

FIG. 2C

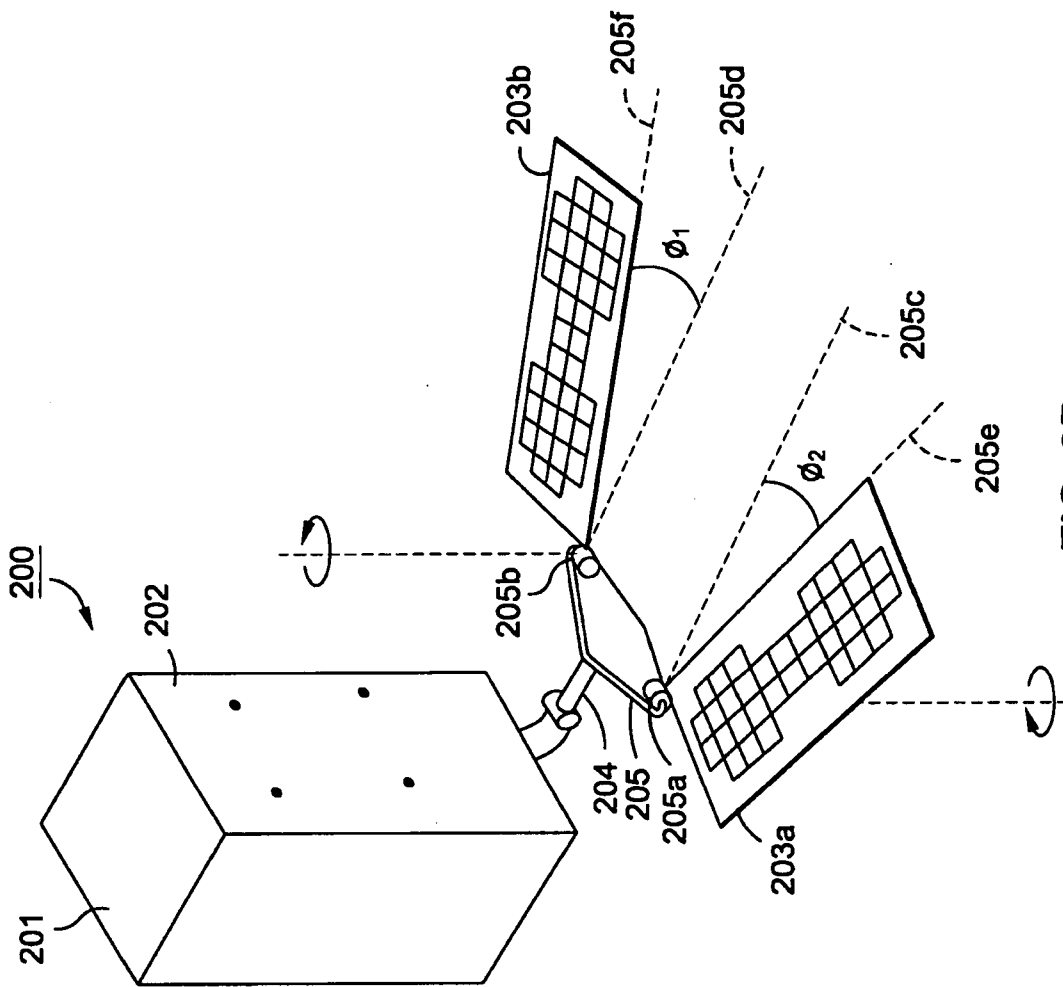

FIG. 2D

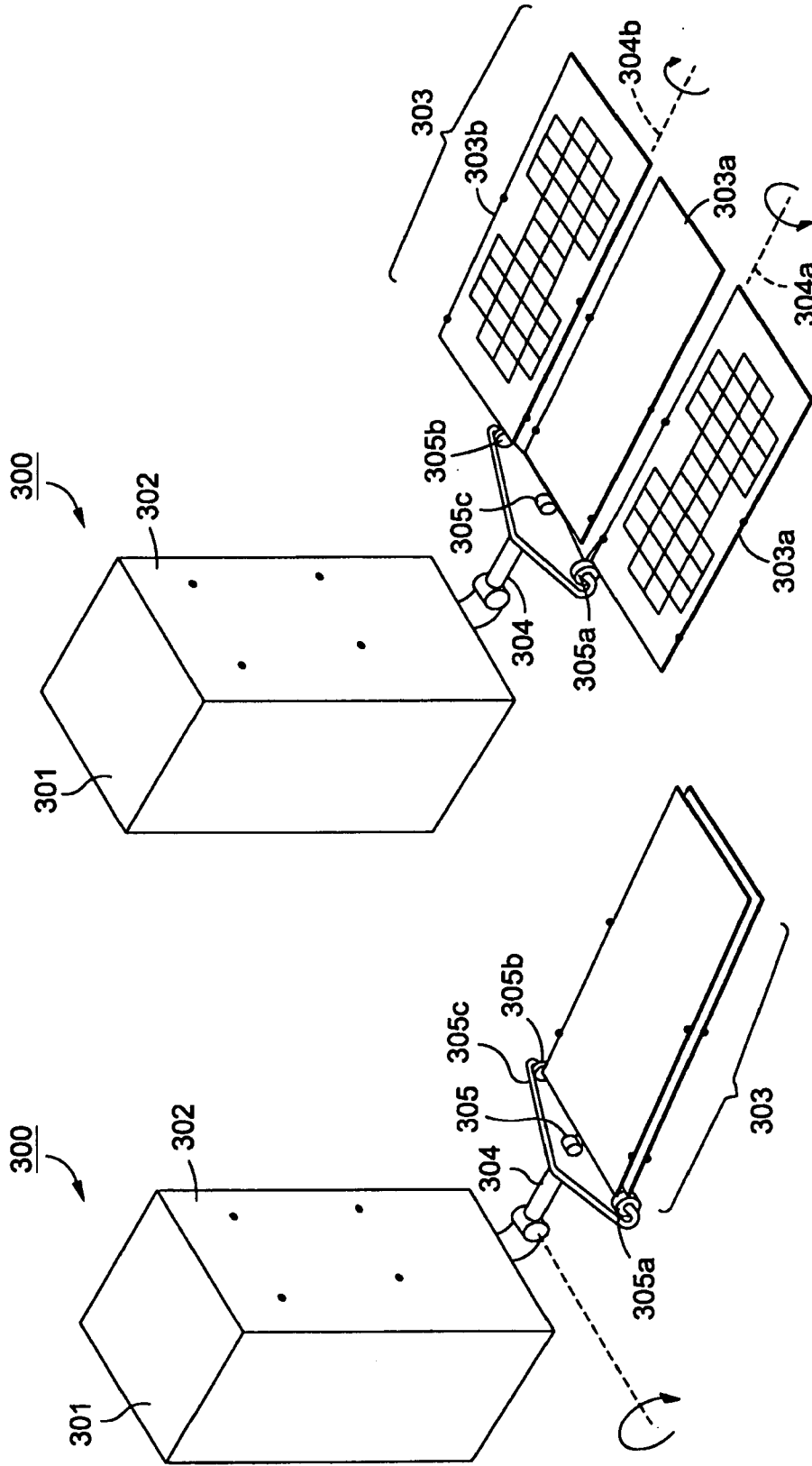

FIG. 3B

FIG. 3A

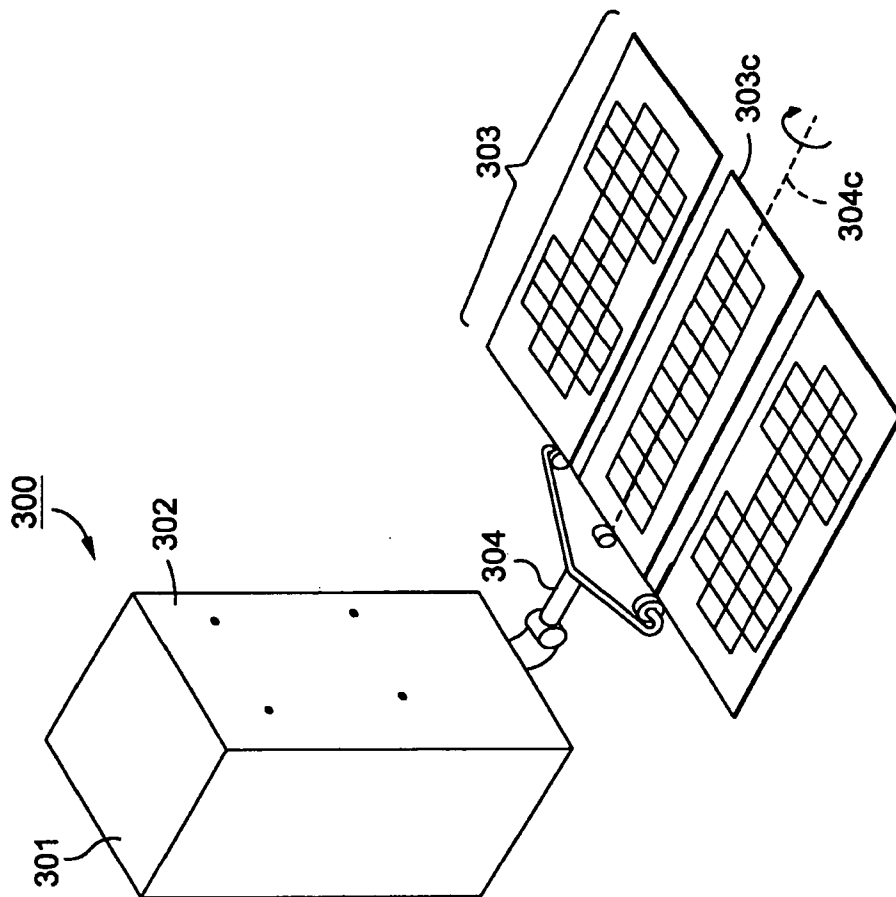

FIG. 3C