

W. B. BARY.
 ANNULAR ROTATING FURNACE.
 APPLICATION FILED AUG. 16, 1909.

970,293.

Patented Sept. 13, 1910.

2 SHEETS—SHEET 1.

Fig. 1.

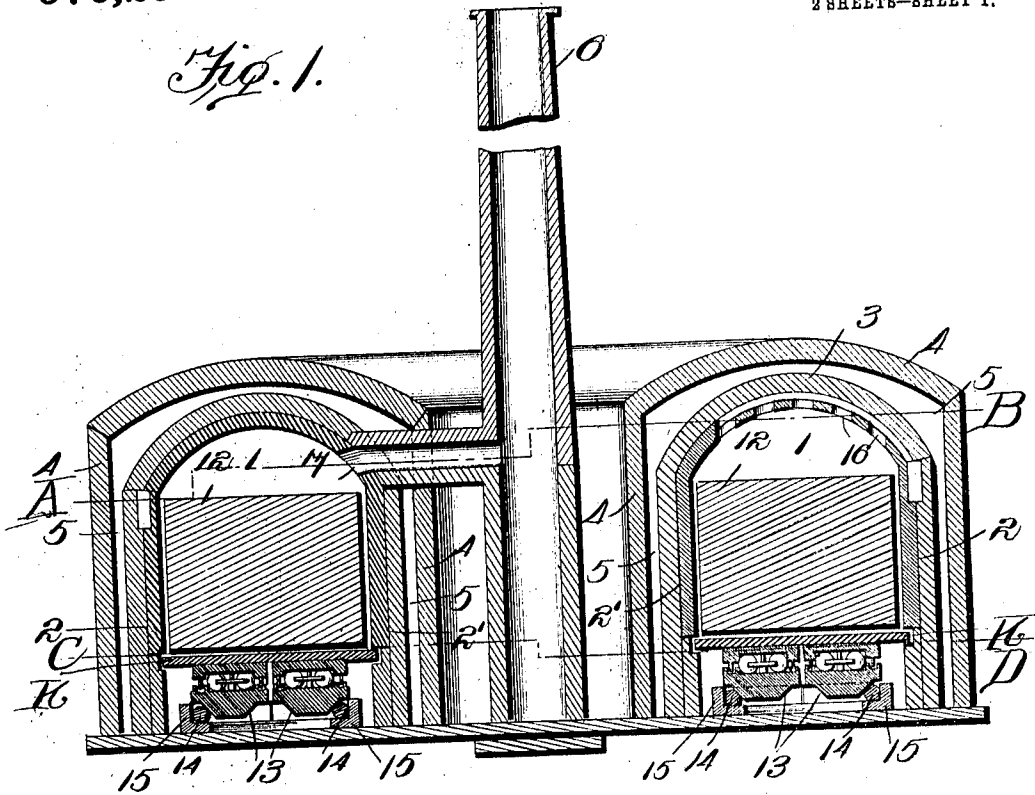
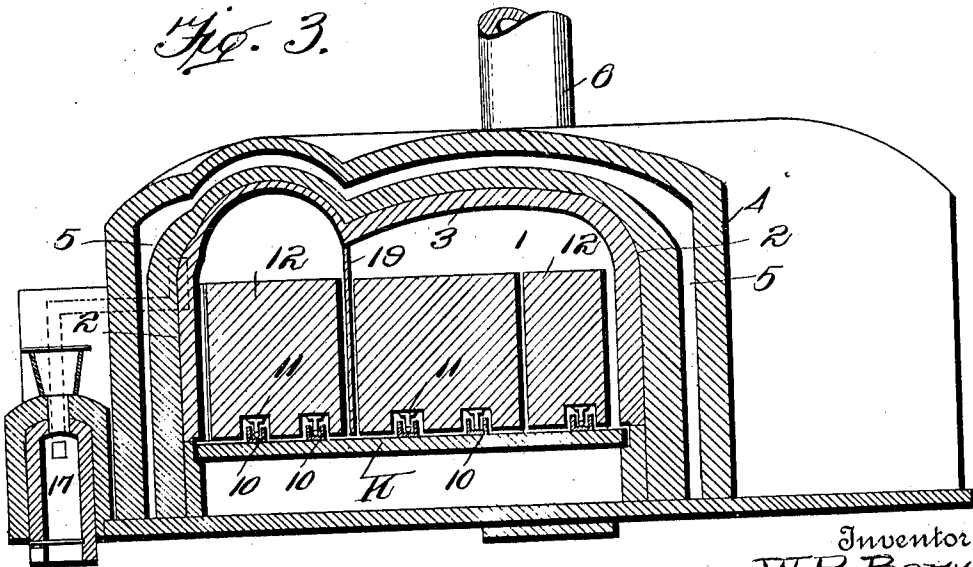

Fig. 3.



Witnesses
Jas. C. Dodge.
Byron B. Collins.

Inventor
W. B. Bary.

W. Williamson, Fisher & Witherspoon
 Attorneys

W. B. BARY.
 ANNULAR ROTATING FURNACE.
 APPLICATION FILED AUG. 16, 1909.

Patented Sept. 13, 1910.
 2 SHEETS—SHEET 2.

970,293.

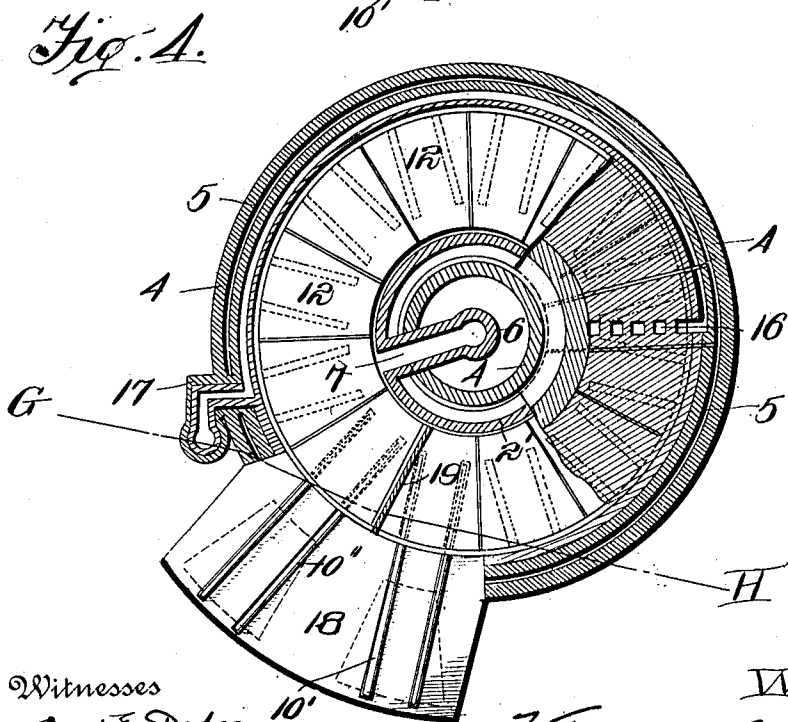
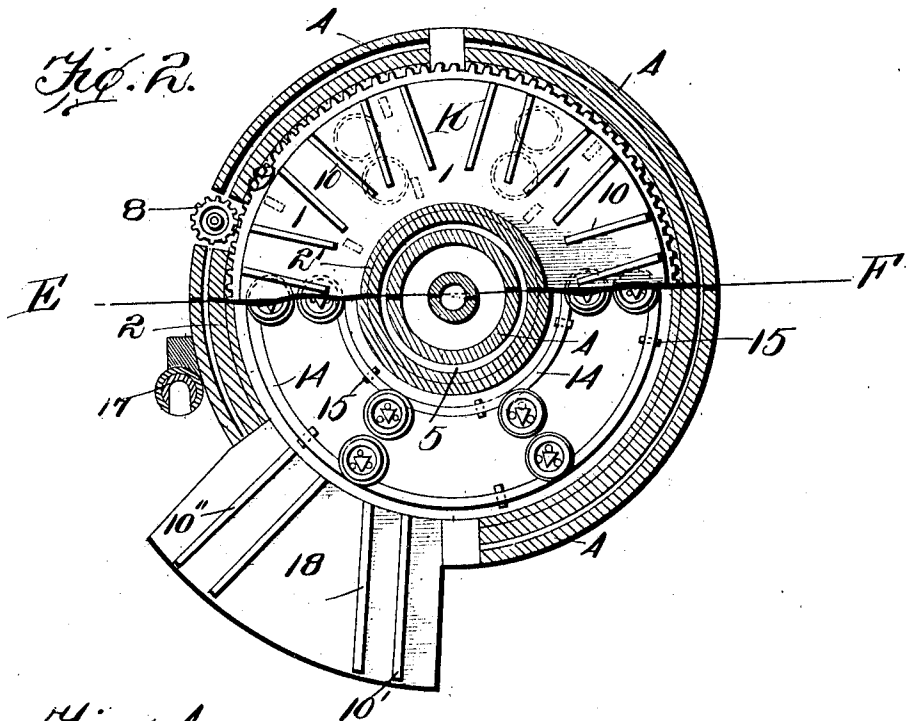

Witnesses
Joe. E. Dodge.
Byron B. Collins.

Inventor
W. B. Bary.
By Williamson, J. H. & W. H. W. J.
 his Attorneys

UNITED STATES PATENT OFFICE.

WILLIAM B. BARY, OF ST. PETERSBURG, RUSSIA.

ANNULAR ROTATING FURNACE.

970,293.

Specification of Letters Patent. Patented Sept. 13, 1910.

Application filed August 16, 1909. Serial No. 513,176.

To all whom it may concern:

Be it known that I, WILLIAM B. BARY, a citizen of the United States of America, and a resident of St. Petersburg, Russia, my post-office address being 7 Isaac's Place, St. Petersburg, have invented certain new and useful Improvements in Annular Rotating Furnaces, of which the following is a specification.

My invention relates to certain new and useful improvements in annular rotating furnaces, and has for its object to provide a furnace intended for the burning of sundry materials, (brick, cement, etc.,) as well as for other purposes.

To these ends the invention consists in the novel details of construction and combinations of parts more fully hereinafter disclosed and particularly pointed out in the claims.

Referring to the accompanying drawings, forming a part of this specification, in which like numerals designate like parts in all the views:—Figure 1, represents a vertical section of the furnace on the line E—F, of Fig. 2; Fig. 2, is a horizontal section of the furnace taken on the line C—D, of Fig. 1; Fig. 3, is a vertical section taken on the line G—H, of Fig. 4; and Fig. 4, is a horizontal section taken on the line A—B of Fig. 1.

The working part 1 of the furnace consists of a suitably supported rotating disk, provided with a large central opening, as shown in Fig. 2, thus forming in fact a large flat ring.

2 and 2' represent two concentric circular walls covered with an arch 3. The whole furnace is placed in a casing 4 of stone masonry, and is separated by a narrow passage 5, the air in which serves as an insulator and decreases thereby the loss of heat from radiation.

In the center of the circle formed by the working part of the furnace and the casing, a stack 6 is arranged, into which the products of combustion enter through a horizontal passage 7, see Figs. 1 to 4, leading from the upper part of the working space of the furnace.

The rotation of the working annular ring K of the furnace is effected with the aid of the gear wheel 8, Fig. 2, which engages teeth carried on the outer circumference of the said ring K, and on the axis of this gear wheel 8 may be provided a pulley, not shown, for the application of power.

Pieces of U beams 10—10, arranged parallel and radially of the ring K divide the entire surface of the frame into equal parts and are fastened in pairs on the upper part of said ring. T beams 11 are inserted in the U beams flange downward, while their bars are embedded into the independent and removable masonry structures 12 occupying substantially the whole of the working part of the furnace, as shown in Fig. 3. The heating of the material takes place on the upper portions.

Below the ring K are concentric circular metal supports 15, L-shaped in cross section, in which rest concentric rails 14, supporting disk shaped pieces having the tapering projections 13 resting on said rails, as shown. Said disk shaped pieces as plainly shown in Figs. 1 and 2, suitably support, as by ball bearings, other disk shaped pieces, which, in turn, support the annular ring K, as illustrated. It is preferred to provide only three balls between said upper and lower disk shaped pieces. The taper projections 13 roll on the circular rails 14 and thereby do away with sliding friction, which otherwise would absorb considerable power in the case of a furnace structure, such as shown. The side shift of the ring K is prevented by the concentric circular rails 14, on which the lower parts of the lower disks roll. As the taper projections 13 of said disks roll on the rails 14, they at the same time, rotate the ball bearings above the same, as will be readily understood.

The furnace shown in the drawings operates preferably with producer gas, but other fuel, or even electricity may be used, if desired.

In operation the circular ring K and with it the brick structures 12, preferably rotate in the direction of the hands of a clock and each of said structures gradually reaches the place of maximum temperature under the gas openings 16. The gas enters from the generator 17, Fig. 4, and after passing along a passage partially encircling the furnace, as shown, and becoming heated it reaches the openings 16, where it encounters the air in the furnace and burns, as will be readily understood. The air, which may be regulated in any suitable manner, enters the furnace at the point 18, and moves above the heated material carried by the structures 12, cooling it gradually but becoming heated itself in its passage to the opening 16. Such

heated air increases the heat effect of the combustion of the fuel in the manner well known. The part of the arch near the openings 16 is made readily removable so as to afford the possibility of replacement in the case of its being burned out; while the rest of the arch is made more permanent as it is less apt to get burned out. Some of the brick work 12 is so made as to be capable of being withdrawn from the furnace on the rails 10 and out onto the platform 18 on which latter paired beams or rails 10 are arranged. The reëntering of the furnace may be accomplished along another pair of beams or rails 10". A vertical wall 19 is provided opposite the central part of the platform, this wall separating the right side of the furnace through which the air enters, from the left from which the products of combustion come out.

The proposed furnace can serve for the burning of finely divided and hard bodies, for drying, for tempering and annealing of glass, for the heating of metals intended for further treatment and for the baking of bread, etc.

What I claim is:—

1. In a rotating furnace, the combination of a supporting ring K; independent structures for holding the material to be heated carried by said ring; horizontally disposed upper disks and horizontally disposed lower disks for supporting said ring; and ball bearings between said upper and lower disks, substantially as described.

2. In a rotating furnace the combination of a supporting ring K; independent removable structures carried by said ring; upper disks and lower disks provided with tapered projections for supporting said ring; ball bearings between said upper and lower disks; concentric rails on which said tapered projections roll; means for feeding air and gas into said furnace; and means for heating both of said gases before igniting the same, substantially as described.

3. In a rotating furnace, the combination of a supporting ring K; independent removable structures carried by said ring; radially disposed rails on said ring on which said structures may be moved; upper disks and lower disks provided with tapered projections for supporting said ring; ball bearings between said upper and lower disks; concentric rails on which said tapered projections roll; concentric supports for said last mentioned rails; means for feeding air and gas into said furnace; and means for heating both of said gases before igniting the same, substantially as described.

4. In a rotating furnace, the combination of a supporting ring K; independent structures for holding the material to be heated, carried by said ring; horizontally disposed upper disks and horizontally disposed lower disks for supporting said ring; ball bearings between said upper and lower disks; a stack around which said ring revolves; a passage 7 connecting the furnace chamber with said stack; and means for admitting gaseous fuel to said furnace, substantially as described.

5. In a rotating furnace, the combination of a supporting ring K; independent structures for holding the material to be heated carried by said ring; upper disks and lower disks for supporting said ring; ball bearings between said upper and lower disks; a stack around which said ring revolves; a passage 7 connecting the furnace chamber with said stack; means for admitting gaseous fuel to said furnace; a second passage partially encircling said furnace in which said fuel is preheated; and a platform 18 for said furnace; substantially as described.

In testimony whereof, I have signed my name to this specification in the presence of two subscribing witnesses.

WILLIAM B. BARY.

Witnesses:

ALEXANDER TSCHENALOFF,
H. A. LOVIAGUIRE.