

S. M. YEAMAN.
Grain Winnower.

No. 4,591.

Patented June 20, 1846.

Fig. 1

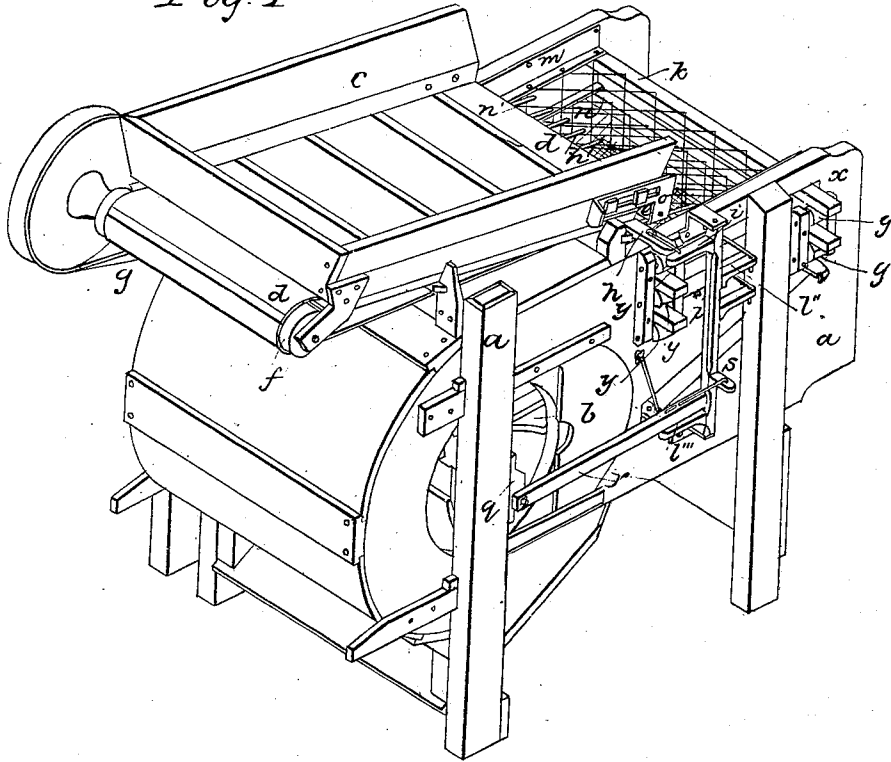
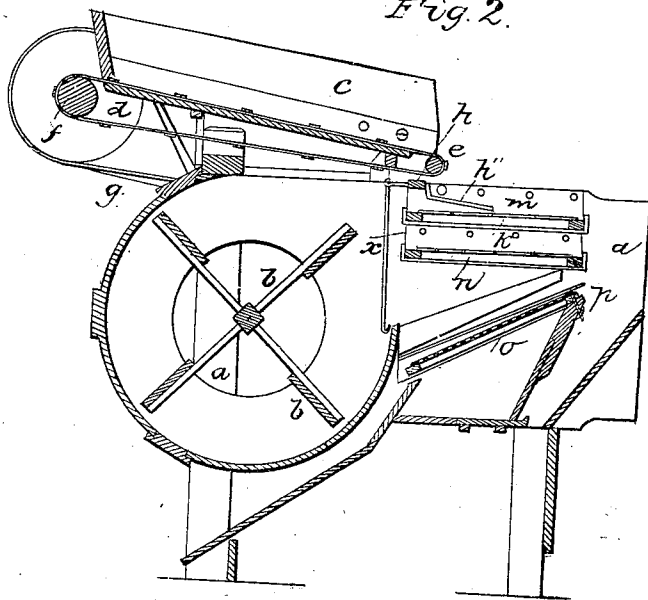

Fig. 2



UNITED STATES PATENT OFFICE.

STEPHEN M. YEAMAN, OF ELIZABETHTOWN, KENTUCKY.

WINNOWING-MACHINE.

Specification of Letters Patent No. 4,591, dated June 20, 1846.

To all whom it may concern:

Be it known that I, STEPHEN M. YEAMAN, of Elizabethtown, in the county of Hardin and State of Kentucky, have invented new and useful Improvements in Wheat-Fans, and that the following is a full, clear, and exact description of the principle or character thereof which distinguishes them from all other things before known and of the manner of making, constructing, and using the same, reference being had to the accompanying drawings, making part of this specification, in which—

Figure 1 is an isometrical projection, and Fig. 2 a longitudinal vertical section of the machine.

The same letters indicate like parts in all the figures.

The nature of my invention consists in dispensing with the shoe used in common fans, and causing each of the riddles to act independently of the others and in opposite directions, thus equalizing the vibrations and preventing the machine from choking.

The construction is as follows: The frame (*a*) and fan (*b*) are constructed similar to those now in use; the hopper (*c*) is an oblong trough standing on the top of the fan case, and inclining down at a proper angle at its front end, which is open, as shown in the drawing—the other end being furnished with a cross piece that is fixed high enough above the bottom of the hopper to allow an endless apron (*d*) to pass between them. This apron or feeding belt is made to pass around a small roller (*e*) at the front of the hopper, and thence under the bottom of the hopper around another larger one (*f*) placed behind said hopper, which is connected with the moving power by a band (*g*). On this apron (*d*) are affixed transverse slats at proper intervals, and by it the wheat or other grain in chaff is fed into the machine. Below the front roller (*e*) above named there is a bar (*h*) that extends across the machine parallel with said roller and projects beyond the sides of the machine resting on two friction rollers on which it plays back and forth, propelled by its connection with an arm (*i'*), extending back from an upright shaft (*i*) placed in suitable bearings outside the frame. This bar (*h*) is furnished with a row of fingers (*h'*) that project forward

over the upper riddle and receive the contents of the hopper and distribute it properly over the riddle. Below the line of the above described teeth there is a narrow horizontal slit (*a*) cut through each side of the machine of a size suitable for the upper riddle (*k*) to slide through the front and back pieces of the frame of this riddle project beyond the sides and rest on small friction rollers (*y*) placed beneath them outside the slit through which they play.

The riddle is connected with an arm (*i''*) that projects forward from the upright shaft (*i*) by a common link by which the riddle is vibrated; the wire of the riddle is made to extend over about one fifth more surface than it could if the riddle was placed in a shoe. To each of its side pieces, a strip of leather (*m*) is attached which is fastened by its other edge to the side of the machine—this prevents the escape of the grain sideways. Another finer riddle (*n*) is placed just below the one above described, and arranged alike in every particular; below these there is a sieve (*o*) which inclines at an angle of about twenty degrees (more or less) backward; at the upper or front end this sieve is suspended on a pivot (*p*) at its center, and its lower end is connected with an arm (*l''*) that extends back from the shaft (*i*) near its lower end, which causes it to play in a slot as the riddles do. It will be observed that the arms which move this sieve, and the finger bar, are on the side of the shaft opposite to those that move the riddles, and consequently when the shaft is vibrated, they will move in contrary directions.

The shaft (*i*) is vibrated by a short crank (*q*) on the axle of the fan shaft, connected by a pitman (*r*) with an arm (*s*) on said shaft, placed at right angles to the others, and standing out from the machine; below the sieve are the usual chute boards for delivering the grain, &c. By this construction the moving parts run much lighter than in the ordinary machine and as the riddles, fingers, and sieve shake in opposite directions there is no danger of clogging, while at the same time the motion and force acting upon the stationary parts of the machine are equalized, and the whole is kept steady when in swiftest operation, and a much greater quantity can be fed into the machine in a given time without choking—

thus admitting the employment of the feeding belt which could not be used in ordinary machines.

5 Having thus fully described my invention, what I claim therein as new and desire to secure by Letters Patent is—

10 1. The mode of operating the riddles, sieve, and finger bars, and combining them with the grain fan, substantially in the manner described, so that each shall move independent of the others, and their motions

be antagonistic, while a much greater surface of riddle can be embraced in the same sized machine than is possible in the ordinary mode of construction. 15

2. I also claim in combination with the above named parts, the feeding apron, as herein before described.

STEPHEN M. YEAMAN.

Witnesses:

J. J. GREENOUGH,
A. P. BROWNE.