

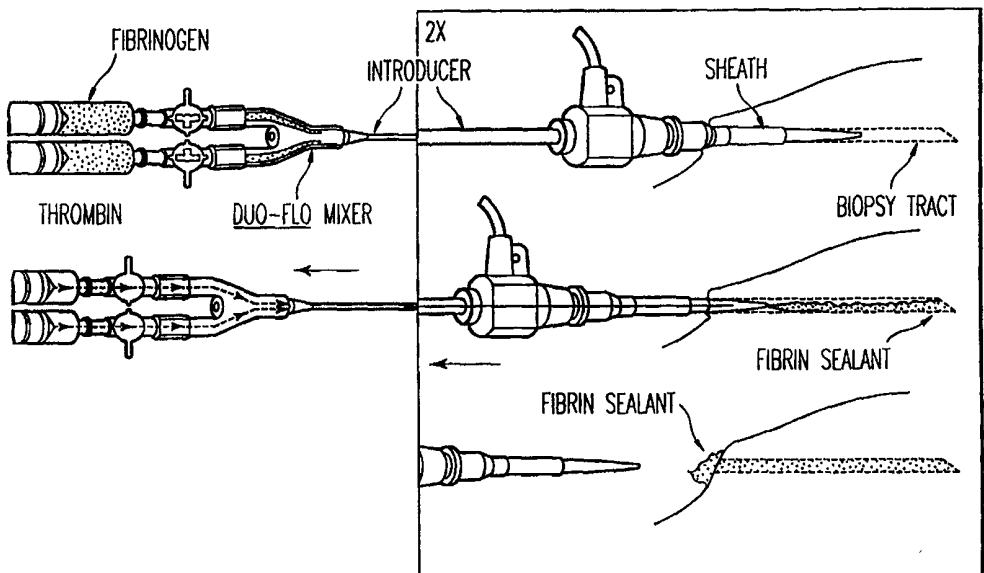

INTERNATIONAL APPLICATION PUBLISHED UNDER THE PATENT COOPERATION TREATY (PCT)

<p>(51) International Patent Classification ⁶ : A61K 9/00</p>	<p>A1</p>	<p>(11) International Publication Number: WO 99/18931 (43) International Publication Date: 22 April 1999 (22.04.99)</p>
<p>(21) International Application Number: PCT/US98/20928 (22) International Filing Date: 9 October 1998 (09.10.98) (30) Priority Data: 08/948,426 10 October 1997 (10.10.97) US (71) Applicant: UNIVERSITY OF VIRGINIA [US/US]; The Towers Office Building, Suite 1-110, 1224 West Main Street, Charlottesville, VA 22903 (US). (72) Inventor: SPOTNITZ, William, D.; University of Virginia, Health Sciences Center, Dept. of Surgery, Box 181, Charlottesville, VA 22906 (US). (74) Agents: KELBER, Steven, B. et al.; Oblon, Spivak, McClelland, Maier & Neustadt, P.C., Suite 400, 1755 Jefferson Davis Highway, Arlington, VA 22202 (US).</p>		<p>(81) Designated States: AL, AM, AT, AU, AZ, BA, BB, BG, BR, BY, CA, CH, CN, CU, CZ, DE, DK, EE, ES, FI, GB, GD, GE, GH, GM, HR, HU, ID, IL, IS, JP, KE, KG, KP, KR, KZ, LC, LK, LR, LS, LT, LU, LV, MD, MG, MK, MN, MW, MX, NO, NZ, PL, PT, RO, RU, SD, SE, SG, SI, SK, SL, TJ, TM, TR, TT, UA, UG, UZ, VN, YU, ZW, ARIPO patent (GH, GM, KE, LS, MW, SD, SZ, UG, ZW), Eurasian patent (AM, AZ, BY, KG, KZ, MD, RU, TJ, TM), European patent (AT, BE, CH, CY, DE, DK, ES, FI, FR, GB, GR, IE, IT, LU, MC, NL, PT, SE), OAPI patent (BF, BJ, CF, CG, CI, CM, GA, GN, GW, ML, MR, NE, SN, TD, TG). Published <i>With international search report.</i></p>

(54) Title: USE OF FIBRIN SEALANT TO MAINTAIN HEMOSTASIS, LYMPHOSTASIS AND PREVENT LOCAL ACCUMULATION OF BODY FLUIDS



(57) Abstract

Fibrin sealant, comprised of thrombin and fibrinogen which are mixed together and polymerized autocatalytically, is used to maintain hemostasis, lymphostasis or prevent local fluid accumulation in situations where bleeding or fluid accumulation may retard recovery, induce or aggravate pain and discomfort, or present a health risk. Fibrin sealant is employed in wound closure where a skin flap is secured to a wound perimeter, as in mastectomies, to incisions made surgically or endoscopically, in orthopedic surgery where bleeding is profuse, and in solid organ biopsies. Fibrin sealant is also effective in suppressing regrowth of surgically excised tumors. Fibrin sealant applied to the area surrounding an opening in a blood or lymphatic vessel due to catheterization is also effective in maintaining hemostasis.

FOR THE PURPOSES OF INFORMATION ONLY

Codes used to identify States party to the PCT on the front pages of pamphlets publishing international applications under the PCT.

AL	Albania	ES	Spain	LS	Lesotho	SI	Slovenia
AM	Armenia	FI	Finland	LT	Lithuania	SK	Slovakia
AT	Austria	FR	France	LU	Luxembourg	SN	Senegal
AU	Australia	GA	Gabon	LV	Latvia	SZ	Swaziland
AZ	Azerbaijan	GB	United Kingdom	MC	Monaco	TD	Chad
BA	Bosnia and Herzegovina	GE	Georgia	MD	Republic of Moldova	TG	Togo
BB	Barbados	GH	Ghana	MG	Madagascar	TJ	Tajikistan
BE	Belgium	GN	Guinea	MK	The former Yugoslav Republic of Macedonia	TM	Turkmenistan
BF	Burkina Faso	GR	Greece	ML	Mali	TR	Turkey
BG	Bulgaria	HU	Hungary	MN	Mongolia	TT	Trinidad and Tobago
BJ	Benin	IE	Ireland	MR	Mauritania	UA	Ukraine
BR	Brazil	IL	Israel	MW	Malawi	UG	Uganda
BY	Belarus	IS	Iceland	MX	Mexico	US	United States of America
CA	Canada	IT	Italy	NE	Niger	UZ	Uzbekistan
CF	Central African Republic	JP	Japan	NL	Netherlands	VN	Viet Nam
CG	Congo	KE	Kenya	NO	Norway	YU	Yugoslavia
CH	Switzerland	KG	Kyrgyzstan	NZ	New Zealand	ZW	Zimbabwe
CI	Côte d'Ivoire	KP	Democratic People's Republic of Korea	PL	Poland		
CM	Cameroon	KR	Republic of Korea	PT	Portugal		
CN	China	KZ	Kazakstan	RO	Romania		
CU	Cuba	LC	Saint Lucia	RU	Russian Federation		
CZ	Czech Republic	LI	Liechtenstein	SD	Sudan		
DE	Germany	LK	Sri Lanka	SE	Sweden		
DK	Denmark	LR	Liberia	SG	Singapore		
EE	Estonia						

TITLE OF THE INVENTION**USE OF FIBRIN SEALANT TO MAINTAIN HEMOSTASIS,
LYMPHOSTASIS AND PREVENT LOCAL
ACCUMULATION OF BODY FLUIDS**

This application is a continuation-in-part, and claims priority from, U.S. Patent Application 08/362,868, allowed. Further, this application claims priority from Provisional Patent Application Serial No. 60/036,813, filed February 3, 1997.

BACKGROUND OF THE INVENTION**Field of the Invention**

This invention pertains to methods of maintaining hemostasis in humans and animals by application of fibrin sealant to wounds, sutures, incisions, and other openings where bleeding and/or fluid accumulation presents a potential health risk. Included within the scope of this invention is the use of fibrin sealant to provide effective wound closure, such as wounds due to radical and modified radical mastectomies, as well as radical and modified radical neck and groin (inguinal) resections, or other operations where a substantial amount of tissue is removed, followed by the sealing of a skin flap over the wound area. Other surgical procedures, such as plastic surgery, thoracic and cardiovascular surgery benefit from the use of fibrin sealant as well. The invention also applies to the use of fibrin sealant to control bleeding and fluid accumulation in orthopedic trauma and surgery, such as knee surgery and replacement. The invention also lends itself to maintenance of hemostasis wherever vessel catheterization or penetration is required, including arterial, venous, and lymphatic vessels. Additionally, the invention finds application in maintaining hemostasis in organ biopsies, particularly organs where tissue removal is prone to bleeding complications, such as liver biopsies and the like. The fibrin sealant may be advantageously employed in preventing the regrowth of tumors after solid tumor removal. Various procedures in brain and ENT surgery benefit from controlled application of fibrin sealant as well. Generically, these inventions involve the application of fibrin sealant to the wound or incision site so as to maintain hemostasis, achieve lymphostasis, and/or prevent local accumulation of body fluids.

BACKGROUND OF THE PRIOR ART

Fibrin sealant is a biological adhesive which has valuable hemostatic and tissue sealing properties. Lindsey et al., Arch. Surg. 125:305-307 (1990). Fibrin sealant has been used in a wide variety of surgical operations, notwithstanding the fact that a commercially available agent is not currently approved for use in the United States. Sanders, et al., J. Surg. Res. 61:65-70 (1996). In U.S. Patent Application Serial No. 08/362,868, filed December 23, 1994, the use of fibrin sealant to suppress femoral arterial bleeding following catheterization, for instance, in connection with cardiac catheterization, is disclosed, wherein the components of the fibrin sealant, fibrinogen and thrombin are introduced separately, and mixed and as mixed introduced into a conduit leading to, but not into, the arteriotomy site. The fibrin sealant seals the periarterial tissue, suppressing bleeding, or maintaining hemostasis. The entire disclosure of U.S. Application Serial No. 08/362,868 is incorporated herein by reference.

The two components of fibrin sealant are fibrinogen and thrombin. Currently, there is no approved source for fibrinogen in the United States. Autologous cryoprecipitation of fibrinogen has been used with some success. Rock, Thromb. Haemost. (1997) and Amery et al., Thromb. Haemost. 73:1463 (1995). Factor XIII is co-purified with fibrinogen in most products at a concentration of about 1-80 IU/ml, and is believed necessary for the catalysis of the polymerization reaction leading to fibrin sealant.

Thrombin is commonly commercially available as bovine thrombin. Blood bank fibrin tissue adhesives employ bovine thrombin, as do many non-commercial sources. A process for the expression and activation of human recombinant thrombin in mammalian cell culture has recently been developed, as well as derivatives that may compete with the natural products. Prunkard et al., Thromb. Haemost. (1997) and Amery, *supra*. The status and characteristics of fibrin sealants is discussed more extensively in Martinowitz et al., Thromb. Haemost. 78:661-666 (1997). This invention employs fibrin sealants comprised of thrombin and fibrinogen derived from any human or non-human source. U.S. Patent 5,443,481, not prior art with respect to the inventors herein, describes a method of introducing hemostatic materials into and through an arterial catheter, to induce clotting, which includes the use of fibrin. Different materials are used to form a vascular plug which is delivered through a dual lumen catheter device as described in U.S. Patent 5,320,639. Collagen is suggested as the vascular plug material employed in this patent.

Fibrin sealant and the components thereof are a naturally occurring, biodegradable adhesive. As such, use of fibrin sealant in humans and animals to suppress bleeding, suppress seroma formation, permit healing without drains, and otherwise maintain hemostasis, is likely to present fewer problems than the selection of a non-naturally occurring material, or one that presents problems in terms of biodegradability, such as cyanoacrylate adhesives, which, due to their greater adhesive strength, are otherwise suitable for use in limited applications, such as wound closure, where two surfaces must be held tightly together.

Unfortunately, the use of fibrin sealant requires highly developed and controlled methods. Fibrin sets up, and is autocatalyzed, by the mixing of fibrinogen and thrombin. Polymerization occurs virtually instantaneously, and if prepared and then subsequently applied, will not adhere to the skin or body tissues, resulting in a sodden, non-adherent mass within the wound or incision, and retarding, rather than improving, recovery. Similarly, application of the fibrin sealant to a particular location must be followed rapidly by completion or closing of the wound or incision, or other major surgical operation, or else the sealant will not adhere to both surfaces meant to be held together. Where vessels are to be occluded to maintain hemostasis, the cure rate of the fibrin sealant must be controlled so as to ensure adherence to the vessel opening, but relatively rapid formation so as to prevent introduction of the fibrin sealant components into the blood stream.

A particularly troubling problem presented in connection with hemostasis in surgery is the removal of solid tumors. The recurrence rate of solid tumors upon surgical removal is extraordinarily high. This is due to the difficulty in removing 100% of the tumor or cancerous cells. Failure to remove all of the cells results in rapid regrowth of the tumor. It is to be particularly noted due to their rapid growth rate, even free floating cells, detached but not removed, at the surgical site, will be rapidly reattached to the former site, and provided with a flow of nutrient due to the high blood supply. Other problems presented in the repair and maintenance of humans and animals include orthopedic surgery, such as knee replacement, where heavy bleeding is commonly encountered, which can lead to a need to stem blood flow through application of a tourniquet, or similar means, which in turn raises the risk of thrombosis. Similarly, solid organ biopsies are not infrequently accompanied by major bleeding, which can cause pain and present major recovery problems in connection with the process which should be relatively straight forward and include only a brief recovery period.

Accordingly, it remains an object of those of skill in the art to develop controllable methods for maintaining hemostasis in a wide variety of situations in the treatment of humans and animals where blood and fluid flow complicate surgery, presents a major recovery issue, or can present a risk of further patient insult.

SUMMARY OF THE INVENTION

This invention broadly employs the administration of fibrin sealant to control bleeding and fluid accumulation, i.e., to effect hemostasis, lymphostasis and prevent local accumulation of body fluids, through tissue adhesion wherever necessary to support patient therapy, reduce recovery time, or advance patient health. Points of application include surgery involving removal of substantial amounts of tissue, followed by closure of the wound by application of a skin flap to the wound perimeter, most commonly encountered in radical and modified mastectomies, inguinal or neck resections, and similar operations as a principle application. A second principle application involves pinpoint delivery of fibrin sealant to mucosal tissues involved in ear, nose and throat, (ENT) surgery, such as buccal, esophageal and olfactory tissues. Incisions and/or wounds in these tissues due to surgery and trauma require hemostasis, that is effectively provided by application of fibrin sealant. The generic scope of this invention also finds application in orthopedic surgery. Many types of bone surgery, represented most particularly by knee surgery, are particularly bloody. Ordinary surgery often requires prior collection of blood for transfusion or possible transfusion, as well as reducing blood flow by tourniquet or similar ligature, which presents the risk of clot formation, and subsequent thrombosis. Application of fibrin sealant to the orthopedic surgery site maintains hemostasis, remarkably reduces blood and fluid flow into the surgical site, reducing the need for transfusions, avoiding the risk of clot formation and accelerating patient recovery. Similarly, solid organ biopsies frequently present the problem of excess bleeding. Hemorrhagic complications associated with needle liver biopsy diagnostic procedures rise to a rate of about 2.2%, with a 50% rate of minor complications that may be attributed to blood accumulation on the peritoneal surface of the liver, or from intrahepatic hematoma. The application of fibrin sealant to the biopsy site, as the biopsy sample is removed, dramatically reduces blood and bile leakage, avoiding complications. Biopsy of other solid organs typically present similar rates of hemorrhagic complications, and are addressed the same way. Plastic

surgery frequently involves mobilization, or complete freeing, of a tissue flap, such as muscle tissue. Fibrin sealant may be applied to suppress bleeding and fluid accumulation at these sites. Other surgeries, such as thoracic surgery, involve muscle mobilization as well. Cardiovascular surgery commonly involves sternum cracking. Fibrin sealant may be used to inhibit blood flow and fluid accumulation in the bone marrow of patients' sternums.

In all of these methods, procedures are provided which include the separate introduction of thrombin and fibrinogen such that they are combined only shortly prior to administration to the site. Where the site of administration is distant from the operator, such as in a blood or lymphatic vessel, in ENT and brain surgery, biopsies and the like, the fibrin and thrombinogen are conveyed to a mixing chamber, by conduits or catheters connected thereto, and then travels a short distance through a joint catheter to the site of application. The mixed fibrin sealant may advantageously be delivered through a dual lumen catheter, in which the fibrin sealant travels in a channel provided which is concentric with the channel of the catheter or endoscope employed, itself.

Where the site is more accessible for the doctor or other individual involved in the treatment, the fibrin sealant may be sprayed or similarly applied directly to the surface, through a spray device which sprays thrombin and fibrinogen in overlapping sprays, such that fibrin sealant sets up and polymerizes directly at the wound site.

In all of these applications, any source of thrombin and fibrinogen is acceptable. The concentration of thrombin in the fibrin sealant principally effects the rate of reaction. Certain applications within the scope of the invention, such as wound closure, may require a more rapid rate of polymerization than other applications, such as hemostasis in tumor removal sites. The concentration of thrombin is about 750- 1,250 IU/ml, based on bovine thrombin. As human and recombinant thrombin becomes more widely commercially available, equivalent concentrations (generally reduced from that required for bovine thrombin) may be employed. In contrast to thrombin, fibrinogen, containing factor XIII, generally impacts the strength of the adhesive, depending on the concentration of fibrinogen in the sealant. Strength can be measured in two different ways, internal bonding strength (glue-glu separation strength) as well as adhesive strength (the bond between the glue and one surface). Typically, fibrin sealants have higher internal bonding strengths than adhesive strengths. Fibrinogen concentration is typically about 10-50 mg/ml, although again, any source of fibrinogen that is pharmaceutically and surgically acceptable, in terms of contamination, may be employed.

BRIEF DESCRIPTION OF THE DRAWINGS

The subject matter claimed herein principally resides in controlled techniques and procedures for the delivery and use of fibrin sealant in maintaining hemostasis. As such, a drawing or illustration thereof is not necessary for understanding of the same. Figures 1-5 are submitted herewith, however, to enhance the reader's understanding of how the procedures are performed, and the results obtained thereby.

Figure 1 is an illustration of a spray unit used to deliver a thoroughly mixed fine layer of fibrin sealant to axillary tissues in the closure of a modified radical mastectomy wound site.

Figure 2 is a graphic comparison of the drainage collected from axillary drains in mastectomy patients treated according to the claimed invention, and those treated according to status quo procedures.

Figure 3 reflects drainage through axillary drains of mastectomy patients in control, and inventive, treatments.

Figure 4 is an illustration of a device suitable for the delivery of fibrin sealant to remote areas, including blood and lymphatic vessel punctures and openings, esophageal and nasal cavities and the like.

Figure 5 is an illustration of a device suitable for delivery of fibrin sealant to a biopsy site.

DETAILED DESCRIPTION OF THE INVENTION

This invention calls for the application of rapidly "setting", or polymerizing, fibrin sealant to wound and trauma sites in which hemostasis is advantageously maintained, to aid therapy, improve patient recovery, or avoid complications. While the application of fibrin sealant in surgical environments predates Applicants' invention, the controlled procedures established herein are believed to be the first to take advantage of the qualities and characteristics of fibrin sealant to maintain hemostasis, lymphostasis and tissue adhesion to improve patient recovery and prevent local accumulation of body fluids. The generic concept finds application in a wide variety of specific procedures. Each of these is discussed below. While wound closure, including closure of mastectomies, neck and groin resections, biopsies, orthopedic surgery, application of fibrin sealant to incisions and surgical sites in ENT environments, catheterization of blood and lymphatic vessels, and tumor removal, are all

associated with specific procedures adopted for the problems and opportunities presented by that particular treatment, each makes use of the mixing of thrombin and fibrinogen shortly before application of the resulting fibrin sealant to the site where bleeding is to be controlled. Each is discussed, in more detail, herein.

Wound Closure

This invention pertains to the use of fibrin sealant to eliminate seroma formation requires effective wound closure immediately following sealant application. This allows the adhesive to seal the skin flap to the underlying chest wall eliminating any potential space for seroma formation and permits the sealant to close lymphatics in the axilla which may contribute to seroma formation.

The specific method includes the following steps:

1. Place a loose lattice ladder of 3.0 coated vicryl suture across the entire length of the wound.
2. Spray the fibrin sealant onto the wound under the skin flaps.
3. Immediately secure and close the skin flaps by pulling the vicryl suture at both ends of the wound to approximate the skin edges.
4. Apply gentle pressure to the skin flaps to secure them in place for approximately 10 minutes using an assistant while a running subcuticular monocryl 4.0 suture is used to close the length of the incision.

Autologous fibrin sealant is used to reduce the potential accumulation of serous fluid after axillary dissection in patients undergoing modified radical mastectomy (MRM) for carcinoma of the breast. Unilateral MRM, including level I and II axillary lymph node dissection, was performed upon 21 patients prospectively randomized into treatment and control groups. Surgical procedures between both groups differed only by the application of autologous Fibrin sealant prior to axilla closure in the treatment group. Drainage was collected and measured at 24-hour intervals following the operation. Drains were removed following the measurement of 40 ml or less during a 24-hour interval. Cumulative drainage for the first 3 postoperative days in the treatment group averaged 198 ± 83 ml compared to 467 ± 138 ml in the control group ($P < 0.0003$). Day of drain removal averaged 3.9 ± 1.7 for the treatment group and 6.9 ± 1.2 for the control group ($P < 0.0001$). In the treatment group, there was a reduction in cumulative drainage over the first 3 days of 268 ml or 57 percent, and there was a reduction in the number of days before drains can be removed of 3.0

days, or 43 percent. The local application of Fibrin sealant significantly reduced the total drainage measured in patients undergoing MRM and enabled earlier drain removal.

More than 180,000 women are diagnosed yearly with breast carcinoma in the United States. Seventy percent of patients afflicted with infiltrating breast cancers undergo modified radical mastectomy (MRM) with axillary dissection. Complications after this procedure include infection, hematoma, wound dehiscence, necrosis of the skin flap, and seroma formation the most common of these complications is seroma accumulation. Conventional treatments for prevention of seroma formation include suction or static drain insertions, closure of dead space by suturing skin flaps to underlying muscle, shoulder immobilization, and tetracycline sclerotherapy. Despite its recent popularity, the surgical insertion of drains in the axilla has its shortcomings. The presence of an axillary drain requires proper management by nurses and patients to assure effectiveness. It is uncomfortable for the patient, causing pain and limited arm movement. In addition, there is a risk of infection, as it serves as a portal for bacterial entrance into the deep tissues.

Patients and Methods

In 21 women who elected MRM with level I and II axillary node dissections for an infiltrating ductal or lobular breast carcinoma agreed to participate in a randomized trial investigating the efficacy of Fibrin sealant application in accordance with a protocol approved by the University of Virginia Human Investigation Committee. Patients were prospectively randomized into the control and the treatment group by lottery. The patients in the treatment group received identical surgical procedures to those patients in the control group, with the exception of Fibrin sealant application.

The fibrinogen was prepared preoperatively from autologous donation at the University of Virginia Blood Bank according to a previously published procedure. Spotnitz, et al., *Am. Surg.* 53:460-463 (1987). This method entailed collecting one unit of whole blood from the donor in accordance with the current standards of the American Association of Blood Banks. The volume of fibrinogen concentrate recovered from the unit of donated blood was 19 ± 2.6 mL with a concentration of $40 \text{ mg/mL} \pm 5 \text{ mg/mL}$. The thrombin was obtained as topical bovine thrombin in a Thrombogen Spray Kit [20,000 units of bovine thrombin (United States Pharmacopeia) and 20 mL isotonic saline diluent (Johnson & Johnson, New Brunswick, NJ)] and was prepared to a concentration of 1,000 units/mL. The surgical sealant applicator (SA no. 4310 spray assembly and AA no. 3660 dural spray applicator tip Micromedics, Inc.,

Eagan, MN) permitted equal volumes of fibrinogen and thrombin to be loaded into individual syringes 104, 104a and connected by a spray applicator tip 107 consisting of two adjacent 0.38 mm pores 106, 106a (Figure 1). This apparatus ensured that equal amounts of these two components were sprayed simultaneously and evenly onto the dried axillary tissue surfaces. The MRM with axillary dissection was carried out in standard fashion by a surgeon blinded as to the use of Fibrin sealant until after surgical dissection, following the procedure of Blake Cady with preservation of the pectoralis muscle but stripping of the pectoralis major fascia. Homeostasis was maintained by the placement of a 3.0 silk suture and by electrocautery.

Prior to skin closure, a 19-French round Jackson Pratt drain was inserted in the axilla and secured with a 3.0 nylon suture. Skin flaps were prepared for closure by placement of a 3.0 coated vicryl suture in a loose ladder. The surgeon was then informed of the patient's randomization status as a member of the treatment or control group. For treatment group patients, the Fibrin sealant spray applicator was inserted between the loose suture loops, and sealant was applied by pressure on pistons 102, 102a. Maximal surface coverage of Fibrin sealant application was obtained without disturbing the vicryl suture. After the spraying of Fibrin sealant onto the exposed axilla and chest wall, the skin flaps were closed in exactly the same fashion in treatment and control groups by securing the previously placed vicryl suture. Gentle, even pressure was applied to the chest wall by an assistant for 8 minutes during the placement of a final running subcuticular 4.0 monocryl skin suture closure. A dry sterile dressing using Coverderm was applied.

Patients were blinded to their status as members of the treatment or control group. They were given identical postoperative instructions as recommended by the American Cancer Society "Reach to Recovery" representative approximately 24 hours after their surgery. Patients were asked to minimize the activity of the involved arm. They were instructed to lift nothing weighing more than 10 pounds and not to lift the arm above the shoulder level. Serous drainage was measured daily; the axillary drain was removed once cumulative drainage dropped to 40 mL or below per 24 hours.

Results

Two parameters were chosen to measure the effectiveness of the Fibrin sealant. First, cumulative drainage was used to measure the total drainage level up to a given postoperative day. Day 3 was specified, because it allowed a reasonable comparison of control and treatment groups. After Day 3, many treated patients no longer had drains, making

comparison difficult. Two of the 11 Fibrin sealant patients had no readings for Day 3 because their drains had been previously removed. In these cases, the drainage was estimated to be half of the previous day's measurement for those days. Second, the number of days to the first drainage reading of 40 mL or less was used to measure the length of time the patient needed to retain a wound drain. This level was chosen because it is normal practice at this medical center to remove drains when output declines to 40 mL for 24 hours.

Mean cumulative drainage volumes were significantly lower for the Fibrin sealant patients ($P < 0.002$) at every postoperative day. The cumulative drainage is shown in Table 1. Cumulative drainage at Day 3 showed a reduction of 268 mL or 57 percent with at least 180 mL or 39 percent, attributable at the 0.95 confidence level. Measurement of the days for drains to remain in place is summarized in Table 2. There is a significant reduction of 3.0 days or 443 percent in the Fibrin sealant group, with at least 1.9 days or 27 percent attributable at the 0.95 confidence level. Statistical significance of differences was measured using Welch's t statistic for cumulative drainage volumes and for day of drain removal.

Factors that could influence data include length of hospitalization, length of operation, age of patient, specimen weight, tumor size, number of lymph nodes removed, and number of lymph nodes found to involve cancer. None of these factors showed a significant difference between the control and Fibrin sealant groups by the Wilcoxon rank-sum test, a test chose as appropriate for small sample sizes drawn from identical populations (see Table 3).

No hypotension, anaphylaxis, or coagulopathy were noted in any of these patients.

The results of this study indicate that Fibrin sealant is effective in reducing the production of seroma fluid following axillary dissection at the time of MRM.

The cumulative volume of axillary drain seroma fluid for 3 days was reduced by 268 mL or 57 percent (Figure 2). The day of axillary drain removal was reduced by 3 days or 43 percent. The use of Fibrin sealant during MRM permits the performance of this procedure without drains using the methods described.

Other investigators have found Fibrin sealant to be ineffective at reducing the volume of seroma drainage in humans. Uden et al., *Eur. J. Surg.* 159:263-265 (1993), Jonk et al., *Neth. J. Surg.* 39:135 (1987), Vaxman et al., *Eur. Surg. Res.* 27:346-52 (1995). These studies, however, suffered either from a small volume of applied Fibrin sealant, a limited number of enrolled patients, or a prolonged period of time between sealant application and wound closure.

In this human prospective, randomized study of 21 patients undergoing application of autologous Fibrin sealant, significant reductions in seroma cumulative drainage were discovered. There appear to be a number of reasons for these findings. First, adequate volumes to seal the axillary potential space were used and a population of patients large enough to prove significance was enrolled. Second, the method of Fibrin sealant application, using a specific spray device with immediate closure of the wound by a previously placed running suture and rapid pressure application, enhanced adhesion of the skin flaps to underlying tissue. Closure should follow Fibrin sealant application by no more than 20 seconds. Third, the concentrations of fibrinogen and thrombin used may have enhanced sealant strength while at the same time maximizing the speed of sealant formation.

The amounts of fibrinogen and thrombin used in this study were chosen for specific reasons. Fibrinogen concentration significantly affects Fibrin sealant strength, whereas thrombin affects sealant clotting time. In general, increased levels of fibrinogen result in a stronger adhesive, and increased levels of thrombin produce a faster clotting time. However, *in vivo* studies suggest that fibrinogen concentrations greater than 60 mg/mL may reduce wound healing and that thrombin concentrations between 10-50 units/ml, preferably 25 and 50 units/mL are best for fibroblast proliferation. Thus, excessively high concentrations of fibrinogen and thrombin may have negative effects.

The level of fibrinogen prior to mixing chosen in this study, 40 mg/mL, is the level available with the cryoprecipitation process used. This level remains less than 60 mg/mL to avoid potential negative wound healing effects but reaches high enough fibrinogen concentration to maximize sealant strength.

A variety of clinical factors may be important in choosing thrombin concentrations. The biochemical and physical properties of the sealant remain important as well. Although the internal bonding strength of Fibrin sealant is enhanced by increasing fibrinogen concentration it may be diminished by an excessive concentration of thrombin that polymerizes local regions of fibrinogen rapidly and prevents effective distribution and mixing of thrombin through the entire fibrinogen matrix, thus reducing overall strength. However, in a clinical setting of MRM, the rapidity of formation of the Fibrin sealant may be the most important factor for success, as adequate sealing of capillaries and lymphatics as well as rapid adhesion of the skin flaps to the underlying chest wall is of paramount importance. The rapid formation of sealant associated with higher concentrations of thrombin may be helpful in achieving these goals. In

rapidly forming sealant allows the adhesive to set up on all portions of the wound, whereas a slowly forming sealant would drip to the most dependent portion of the wound before polymerizing. The concentration of thrombin prior to mixing used in this study, 1000 units/mL, has been previously used in this institution without difficulty and produces a rapidly forming adhesive which immediately adheres and localizes to specific sites. Further work to determine the most effective concentrations of thrombin and fibrinogen for specific clinical application is needed.

In this study, no complications were noted in any patients related to Fibrin sealant (although one patient developed pneumonia in the postoperative period). The complications of hypotension, anaphylaxis, and coagulopathy previously noted to occur rarely but occasionally using thrombin associated with Fibrin sealant were not noted in this 21-patient study.

It is notable that, although axillary drainage is very large on Days 1 and 2 in the control group (Figure 3), this volume of drainage is greatly reduced in the Fibrin sealant-treated group. This early reduction in drainage is consistent with *in vivo* results documenting that the wound strength of incisions treated with Fibrin sealant is maximally augmented between 0 and 48 hours of application. Jorgensen et al., J. Surg. Res. 42:234-241 (1987). The early reduction is also consistent with data suggesting that the lifespan of Fibrin sealant may be reduced to less than 25 percent remaining at 72 hours postapplication. Pipan et al., J. Surg. Res. 53-402-407 (1992). Thus, Fibrin sealant appears highly effective in the early clinical period following MRM for preventing large volumes of seroma fluid production. It avoids areas of local seroma formation that can predispose the wound to later, larger accumulations, producing a potential space where skin flap-to-chest wall apposition and healing have not occurred. Consequently, the use of Fibrin sealant with a short period of skin flap pressure application allows the surgeon to eliminate the need for drain placement at the time of MRM.

Table 1

<i>Cumulative Drainage (Mean \pm SD, mL)</i>			
Postoperative Day	Control	Treatment	P Value*
1	127.5 \pm 53.1	61.8 \pm 29.5	0.0020
2	323.3 \pm 95.9	138.2 \pm 48.3	0.000050
3	467.0 \pm 137.6	198.9 \pm 83.3	0.000046
4	567.0 \pm 168.6	274.4 \pm 153.0	0.00029
5	642.2 \pm 191.3	312.7 \pm 201.2	0.00035
6	643.2 \pm 220.1	331.3 \pm 226.4	0.00092
7	719.2 \pm 246.3	339.8 \pm 237.1	0.0010
8	736.7 \pm 260.2	344.0 \pm 242.6	0.0011
9	745.7 \pm 267.3	346.1 \pm 245.3	0.0011

* By Welch's *t* test.

Table 2**TABLE 2. Time of Drain Removal (Mean \pm SD, Day)**

Treatment	3.9 \pm 1.70
Control	6.9 \pm 1.19

$P = 0.000091$ by Welch's *t* test.

Table 3**TABLE 3. Characteristics of Patients and Operations**

	Control	FS	P Value*
Length of hospitalization (days)	1.41 \pm 0.69	1.18 \pm 0.60	0.51
Length of operation (hours)	2.20 \pm 0.23	2.25 \pm 0.27	0.86
Specimen weight (g)	30.2 \pm 4.2	31.9 \pm 6.8	0.60
Tumor size (cm)	1.42 \pm 0.48	1.72 \pm 0.68	0.23
Age	62.9 \pm 14.9	56.5 \pm 13.3	0.31
Cancer nodes	0.40 \pm 0.70	1.32 \pm 2.04	0.17
Total nodes	13.7 \pm	14.7 \pm 2.8	0.43

* By two-sided Wilcoxon rank sum test.

The wound closure method of this invention has been described, above, in connection with breast mastectomies. The method is not so limited. Similar surgical procedures in which substantial amounts of tissue are removed, and the wound closed by application of the skin flap overlying the tissue removed, can benefit from the same procedure. Typical examples of such surgical operations are neck and inguinal resections. It is to be noted that both radical and modified radical removals may benefit from this process.

Surgical Processes

In addition to mastectomies and resections discussed above, the use of fibrin sealant to maintain hemostasis, lymphostasis and prevent local accumulation of body fluids finds application in a wide variety of other surgeries. Plastic surgery, including reconstructive and cosmetic surgery may be effectively enhanced by the use of fibrin sealant. Thoracic surgery, including special "muscle sparing" incisions, may also make advantageous use of fibrin sealant. The use of fibrin sealant in cardiovascular surgery, per se, has been known for some time. The Applicants have discovered, however, that fibrin sealant is advantageously used to suppress bleeding in the bone marrow of the sternum.

Plastic surgery presents a variety of situations in which blood and/or lymphatic fluid accumulation complicates both the surgical operation itself, and recovery. Burn victims are frequently presented, as the first step in repair and reconstructive surgery, with burn wound debridement, where the burnt skin, and underlying tissue, is debrided or literally rubbed away, to expose underlying tissue for the purposes of grafting. Such operations are frequently bloody in nature. Fibrin sealant may be applied directly to the debrided areas, and suppress fluid

accumulation. Fibrin sealant may provide a bedding support for grafts applied to the debrided area. A variety of surgical processes involved with enhancement of appearance present similar issues to those encountered in mastectomies and resections. Principle amongst these is breast argumentation or reduction, as well as removal of previously inserted breast implants. Fibrin sealant is effectively used to close the wound, as described above, and to occupy the space created by removal of the breast implant, or by breast reduction. Insertion of the fibrin sealant into this space prevents accumulation of blood fluid, and permits recovery without the insertion of drains, or seroma formation.

Plastic surgery frequently involves the liberation of a portion of a large muscle, particularly the latissimus dorci, as a flap. This may be either a free (mobile) flap or pedicel. At the spot of mobilization or separation, heavy bleeding may be sustained. Application of fibrin sealant directly to these points will suppress bleeding, allowing quick recovery without infection or complication.

Thoracic surgery usually involves an incision to the fifth intercostal space, proceeding through the back of the patient. This involves penetration of a substantial amount of muscle mass. Rather than proceeding directly through the muscle mass, "muscle sparing" incisions have been developed. Thoracotomies of this type may involve mobilization along the length of one or more muscles. This allows the surgeon to push the muscles out of the way, rather than cut through, enhancing recovery. At the points of mobilization, however, a substantial amount of fluid drainage occurs, which will include blood, and may include lymphatic fluid accumulation. Tissue separation of this type gives rise to fluid flow in a plurality of spots. Fluid flow can be suppressed substantially by direct application of the fibrin sealant to the point or points of mobilization. This permits maintenance of hemostasis and lymphostasis, avoiding the local accumulation of body fluid and enhancing recovery.

Cardiovascular surgery requires the opening of the thoracic cavity, and typically involves opening the sternum. The bone marrow of the sternum is subject to heavy bleeding. The current procedure for addressing this problem is to apply bone wax directly to the bone marrow. This introduces a foreign body to the patient, and imposes a substantial threat of infection, which may be life threatening.

Instead of bone way application, bone marrow bleeding may be suppressed by application of fibrin sealant directly to the exposed bone marrow. As fibrin sealant is a natural product, it does not require the introduction of a foreign body, and does not increase the risk

of infection. Indeed, fibrin sealant can be combined in this application, and the applications described herein, with any of a wide variety of antibiotics, to not only avoid any risk of infection by the incorporation of foreign bodies, but to suppress the risk of infection always presented by open surgery.

These surgical procedures expose the point of bleeding, lymphatic leakage and fluid accumulation. Thus, as with wound closures, the fibrin sealant can be applied directly to the point or points exposed, by application of thrombin and fibrinogen directly to the site or sites to be treated, using a convenient spray applicator which applies the two reactive components in overlapping sprays.

ENT Procedures

Trauma and operations in the ear, nose and throat environment, typically involve incisions or wounds in mucus cavities, the most prominent of which are the buccal, or other oral cavity surfaces, esophageal mucus membranes, nasal cavity membranes and the like.

One exemplary surgical procedure that involves substantial irritation of these membranes is conventional tonsillectomy. Profuse bleeding at tonsillectomy sites has been linked to perceived patient pain, and prolonged recovery. The tonsillectomy site is difficult to reach to address hemostasis through conventional measures.

Using the Fibrin sealant of the invention, sealant is delivered directly to the tonsillectomy site, through an extended catheter, of the type illustrated in Figure 4, wherein fibrinogen and thrombin are introduced through separate syringes 202, 202a into a mixer, such as that sold by Duo Flow, where the two components are mixed immediately prior to introduction to the conduit 208, which is extended to lead directly to the site of tonsillectomy. Saline, or other carrier substance, is introduced through syringe 204, using 3-way stop cocks. These methods of directly applying fibrin sealant to a remote bleeding site are demonstrated to substantially reduce bleeding experienced. This, in turn, is linked to a significant reduction in pain, and accelerated recovery.

Similar problems are posed by surgery in or about the brain, and upper neck. In these environments, surgery is usually conducted through an endoscope, with various surgical instruments operating at the end of the endoscope, to allow precise placement and operation. Ordinarily, such sites are remote, making hemostasis and wound control extraordinarily difficult. Through the device illustrated in Figure 4, but substituting an endoscope for catheter 208, fibrin sealant can be delivered directly to the point of suture or incision. In such

a process, a dual lumen endoscope may be used, wherein the Fibrin sealant is delivered through a conduit concentric about the optical fiber of the endoscope. This permits controlled, precise deposition of Fibrin sealant, and a substantial reduction in bleeding.

Solid Organ Biopsies

Organ tissue biopsy provides clinicians with invaluable information for diagnosing the existence and severity of diseases specific to the organ sampled. Although this invention is generally applicable to any solid organ biopsy, liver biopsy has been the subject of extensive research, and this invention is discussed in terms of application to liver biopsy herein. Use in connection with other organs, conventionally subject to biopsy, is made according to identical methods.

Percutaneous liver biopsy is associated with a near 50% rate of minor complications, and a significant rate of major complications, generally due to hemorrhaging. Fatalities are nearly always related to hemorrhaging. In addition to blood, bile leakage is a potential complication. Together with bleeding and fluid accumulation, bile leakage can lead to the formation of subphrenic abscesses. Piccinino, J. *Hepatology* 2:165-173 (1986).

This invention provides a method to ensure hemostasis at the tract site after needle biopsy, reducing complications and their associated costs. It also provides for some measure of safety in patients with severe coagulopathy, who are at risk for bleeding complications, typically individuals in need of diagnostic liver tissue assessment. Fibrin sealant is delivered to the biopsy tract employing a modification of the device of Figure 4, illustrated in Figure 5. In this embodiment, the conduit 208 of Figure 4 is equipped with a biopsy sampler, which is first extended into the organ, and then withdrawn. As the biopsy sample is withdrawn, Fibrin sealant is extruded through a channel in the biopsy needle, providing Fibrin sealant directly to the site of the tract, and preventing bleeding. Maintenance of hemostasis through this method has been demonstrated through *in vivo* experimentation.

In Vivo Experiments

All animals were treated in accordance with the "Position of the American Heart Association on Research Animal Use."

Animal Preparation

Eight mongrel dogs (31.8 ± 2.7 kg) were anesthetized with intravenous phenobarbital (28 mg/kg to effect)(Veterinary Laboratories, Lenexa, KS). The dogs were incubated and ventilated mechanically with a dual-phase control respirator pump (Model 613, Harvard

Apparatus, Dover, MA). To maintain anesthesia, additional intravenous doses of phenobarbital (2 ml, 1 grain/ml) were administered as needed. In order to allow direct observation of the liver, a subcostal incision was made extending from the midline to the right costophrenic angle. Plasmalyte (Baxter Healthcare, Deerfield, IL) was administered intravenously (1000-1500 ml) over the course of the experiment to keep the dogs sufficiently hydrated. The animals were anticoagulated with systemic bolus doses of heparin at 15 min intervals to achieve and maintain a mean elevated activated clotting time (ACT) measured using a Hemochron apparatus (Model 801, International Technidyne Corporation, Edison, NJ) with a mean of 387 ± 94 (mean \pm SD).

Biopsy and Sealant Delivery Procedure

8 French sheaths (Hemaquet II, 6468, USCI, Tewksbury, MA) were modified to a length of 1 cm for use in each experiment. In each animal, two sheaths were placed into the parenchyma of the left lobe of the liver under direct vision after laparotomy. One biopsy was taken through each sheath using a Tru-Cut 15 gauge manual cutting needle (#2N2702X, Baxter Pharmaseal, distributed by Allegiance Health Care, McGaw Park, IL). Fibrin sealant was then immediately applied down one sheath into the tract side via an administration assembly connected to an introducer as shown in Figure 5. The sealant administration assembly consisted of two 3 cc syringes, one containing 2 ml of Fibrinogen and one containing 2 ml of thrombin, attached using three-way luer lock stopcocks (Discofix, Burr Medical Inc., Bethlehem, PA) to a single DuoFlo mixer (Haemedics, Inc., Malibu, CA). The other biopsy tract site was left untreated as a control. The sheaths were then removed and tract sites were observed over five minutes for signs of gross blood and bile leakage. Following observation, a final ACT was taken to ensure that the dogs remained sufficiently anticoagulated over the course of the experiment. The dogs were then euthanized.

Statistics

Because this study uses the same animal liver for comparing Fibrin sealant-treated and control biopsy tract sites, McNamar's test for correlated proportions was chosen to evaluate the significance of success of achieving hemostasis. Thus, in order to assess statistical significance, a test based on exact binomial probabilities was used. All hypothesis testing was based on a 0.05 level of significance and was two-sided.

Results

One animal was excluded over the course of the experiments. This animal had abnormally high ACT measurements which made it unsuitable for use. Consequently, a total of eight consecutive dogs were available for final analysis.

In this heparinized model, all eight control biopsy sites showed signs of gross leakage of blood with or without bile while none of the Fibrin sealant-treated tract sites showed evidence of significant blood and bile leakage ($p = 0.0078$) when observed for five minutes following sheath removal.

Blood and Lymphatic Vessels

Parent Application Serial No. 08/362,868, incorporated herein-by-reference, describes in detail a method for reducing arterial bleeding due to catheterization, by application of Fibrin sealant to the periarterial tissue area around the arteriotomy. In this process, patented by one of the inventors herein, Fibrin sealant is introduced to the periarterial tissue adjacent an arteriotomy site in which a catheter has been inserted, withdrawing the catheter from the arteriotomy as the Fibrin sealant is introduced, and allowing the Fibrin sealant to form a seal about the arteriotomy. In this method, using the apparatus of Figure 4 described above, Fibrinogen and thrombin are separately introduced into a conduit, through a mixer, the conduit having its opposite end opening at the periarterial tissue. This permits mixing of the Fibrinogen and thrombin prior to delivery to the periarterial tissue. As set forth in the parent application, this method is generally applicable to vessels of all types, including veins and lymphatic vessels, as well as arteries. Although less commonly catheterized, where patient treatment requires catheterization of any blood or lymphatic vessel where post-catheterization bleeding is a potential complication, the application of Fibrin sealant thereto is indicated.

Orthopedic Surgery

Orthopedic surgery frequently presents a significant challenge to hemostasis and control of blood accumulation. Although a variety of orthopedic surgeries present similar concerns, knee repair and replacement is a particularly bloody operation. Conventional measures to control bleeding present a risk of clot formation, and thrombosis. Typically, such risks are combated by the use of heparin and related anticoagulants. The use of these drugs, of course, would only exacerbate the bleeding problem. Application of sprayed Fibrin sealant, using an apparatus such as that illustrated in Figure 1, has been demonstrated to significantly reduce bleeding in *in vivo* models.

Materials and Methods

Anesthetized and heparinized 9 activated clotting time 308 ± 105 sec., mean \pm SD) dogs ($n = 9$) underwent bilateral knee arthroplasty under brief pneumatic tourniquet control. After surgical dissection and osteotomy of the distal femur and proximal tibia, each animal had 3 ml of cryo-based Fibrin sealant applied to one joint with the other joint serving as control. Each knee incision was closed with a 1/2" suction drain in place, the tourniquets were released, and the bleeding from each joint was measured at 15 min intervals for 2 hours.

Results

The cryo-based Fibrin sealant-treated knees over 2 hours had less ($p < 0.05$) overall bleeding per 15 min, 52.2 ± 32.3 ml, than control knees, 111.7 ± 69.4 ml. The greater the bleeding from the control joint per 15 min, the greater the difference between control and cryo-based Fibrin sealant-treated knees, and the more the benefit of using this cryo-based Fibrin sealant ($p < 0.05$). The ACT and time after completion of the operative procedure did not correlate with the increased blood loss in the control as compared to cryo-based Fibrin sealant joint.

In this *in vivo* model, cryo-based Fibrin sealant reduces bleeding after knee arthroplasty. This appears to be an excellent method of reducing bleeding during knee replacement operations and is similarly useful in other orthopedic procedures as well. In addition, the animals in this study were heparinized, suggesting that cryo-based Fibrin sealant may even be an effective means of reducing hemorrhage during procedures in which forms of preoperative systemic anticoagulation are employed. Anticoagulation during orthopedic procedures helps to reduce the risk of deep venous thrombosis, pulmonary embolus, and death. Thus, cryo-based Fibrin sealants allow the orthopedic surgeon to employ the beneficial effects of anticoagulants while avoiding the undesirable hemorrhagic complications which may accompany their use.

Prevention of Tumor Regrowth

When solid tumors are detected prior to metastasis, standard surgical practice is to remove the tumor. Regrettably, tumor regrowth in the original tumor cavity is a common phenomenon. There is substantial evidence that this is due to tumor cells that remain behind upon removal of the solid tumor. These cells proliferate in the blood-rich environment. It is typically the case that no tumor cells are left at the site of excision, rather, tumor cells cut or shaken loose remain in the tumor cavity, and then reattach. One approach has been to attempt

to reduce tumor regrowth by the administration of antineoplastic drugs, such as adriamycin. This practice has not been entirely successful. Administration of Fibrin sealant to the wound where the tumor has been removed is surprisingly effective in suppressing tumor reoccurrence. Preliminary trials indicate that Fibrin sealant, alone, has a high degree of effectiveness in suppressing tumor regrowth. One advantage of the use of Fibrin sealant treatment in this embodiment is that it may be combined with drugs designed to prevent tumor regrowth.

Again, Fibrin sealant is applied using the device of Figure 4, with the delivery catheter positioned at the point of tumor removal. As many tumors are removed endoscopically, Fibrin sealant delivery can be conveniently achieved using a dual lumen endoscope/catheter, as described above. In controlled experiments, animal models had tumors implanted, and removed. When the removal was treated with adriamycin alone, 100% of the animals had a recurrent tumor. Where the tumor was removed without any treatment at all, 4 out of 6 animals exhibited tumor regrowth. The administration of Fibrin sealant, however, suppressed tumor growth 100% of the time. Whether administered with adriamycin in combination, or administered alone, 0 out of 11 animals treated with Fibrin sealant exhibited tumor regrowth. While this study is not sufficiently large and controlled to establish a clear *in vivo* model for operation of the Fibrin sealant, it does clearly demonstrate the effectiveness of Fibrin sealant in suppressing tumor reoccurrence.

This invention has been described both generically, and by specific embodiment. Various aspects of the invention have been described serially, but the inventions commonly use the administration of Fibrin sealant, a combination of thrombin and Fibrinogen to a site immediately after surgery, to suppress bleeding. In all cases, application of Fibrin sealant has dramatically reduced blood and fluid accumulation. The invention is not limited to the examples set forth. Other organs, organelles, operations and procedures will occur to those of ordinary skill in the art, involving the application of Fibrin sealant for rapid closure or maintenance of hemostasis, without the exercise of inventive skill. Such alternatives, remain within the scope of the invention, unless excluded by the recitations of the claims set forth below.

CLAIMS:

1. A method for closing wounds resulting from removal of tissue under a skin flap overlying a surface of said wound, comprising:

(a) providing a suture connecting said skin flap and the perimeter of said wound which can be quickly closed to draw said skin flap into contact with said wound perimeter,

(b) applying fibrin sealant to said wound surface, and immediately thereafter,

(c) drawing said skin flap to said wound perimeter by tightening said suture and securing said skin flap in position over said wound such that substantially all space between said wound surface and said skin flap is filled by said fibrin sealant, and

(d) allowing said fibrin sealant to fully polymerize.

2. The method of Claim 1, wherein said removal of tissue is effected by an operation elected from the group consisting of a mastectomy, a neck resection and an inguinal resection.

3. The method of Claim 2, wherein said wound heals without the provision of drains for release of liquid accumulating in said wound.

4. A method of maintaining hemostasis in a wound in a patient, comprising, applying fibrin sealant to said wound site so as to occlude blood and lymphatic vessels at said wound site, and allowing said fibrin sealant to polymerize and set, wherein said fibrin sealant is prepared by mixing thrombin and fibrinogen prior to applying said fibrin sealant to said wound such that said fibrin sealant is not fully polymerized at the time of being applied to said wound, wherein said thrombin is present in a range of 750 units/ml -1250 unit/ml, and said fibrinogen comprises Factor XIII and is present in a concentration, in said sealant, of 10-50 mg/ml.

5. A method of maintaining hemostasis at the site of a solid organ biopsy, including suppression of bleeding and fluid accumulation induced by said biopsy, comprising introducing fibrin sealant to said biopsy site while tissue obtained from said biopsy is removed from said solid organ, and allowing said fibrin sealant to polymerize at said biopsy site.

6. The method of Claim 5, wherein said biopsy tissue is withdrawn by insertion and removal of a needle, and said fibrin sealant is introduced to said biopsy site through a channel in said needle during said removal of said needle from said organ.

7. A method of maintaining hemostasis in the area surrounding an opening in a blood or lymphatic vessel in a patient caused by introduction of a catheter there into, comprising introducing fibrin sealant along a conduit concentric with said catheter, said fibrin sealant

being comprised of thrombin and fibrinogen mixed prior to introduction to said conduit such that said fibrin sealant has not fully polymerized at the time of said introduction, and ejecting said fibrin sealant from said conduit at the site of said vessel opening as said catheter is withdrawn, whereby said fibrin sealant polymerizes in a tissue space surrounding said vessel opening.

8. A method of maintaining hemostasis in an orthopedic surgical procedure comprising cutting of tissues in proximity to bone, said method comprising spraying fibrinogen comprising Factor XIII onto said cut tissues and spraying thrombin onto said cut tissues such that said thrombin and fibrinogen are intimately mixed to form a fibrin sealant on said cut tissues, and allowing said fibrin sealant to polymerize on said cut tissues.

9. A method of maintaining hemostasis at an incision made endoscopically, comprising introducing fibrin sealant into the area of said incision by mixing fibrinogen and thrombin and directing it through a conduit concentric with an endoscope used to make said incision, said conduit terminating at the area of said incision, directing said fibrin sealant out through said conduit into said incision area and allowing said fibrin sealant to polymerize.

10. A method of suppressing tumor regrowth following surgical removal of a tumor comprising,

(a) surgically excising as much of said tumor as possible,

(b) filling the area where said excised tumor was with fibrin sealant and allowing said fibrin sealant to polymerize in said area.

11. The method of Claim 10, wherein said fibrin sealant is combined with a pharmaceutical preparation effective in inhibiting tumor regrowth.

12. A method of performing cardiac surgery comprising opening of the sternum of a patient, wherein said method further comprises applying fibrin sealant directly to bone marrow exposed by said sternum opening, and allowing said sealant to polymerize on said exposed bone marrow, whereby bleeding at said exposed bone marrow is suppressed.

13. The method of Claim 12, wherein said fibrin sealant further comprises an antibiotic.

14. A method of performing thoracic surgery on a patient, wherein at least one portion of a muscle of said patient is mobilized as one step in a thoracotomy, wherein said method comprises applying fibrin sealant to said muscle at points where said muscle is mobilized.

15. A method of debriding burnt tissue of a burn patient, wherein fibrin sealant is applied to tissue exposed by burn tissue debridement, so as to suppress fluid accumulation and maintain hemostasis and lymphostasis in an area of said debridement.

16. A method of mobilizing a flap of muscle tissue of a patient undergoing plastic surgery, wherein at points where said muscle tissue is mobilized, fibrin sealant is applied to suppress fluid accumulation.

17. A method of removing a breast implant from a patient, comprising removing said implant from said patients' body to thereby create a void where said implant previously resided, and filling said void with fibrin sealant, whereby fluid accumulation in and around said void is suppressed.

18. The method of Claim 17, wherein said implant removal is conducted, and recovery of said patient from said implant removal is effected without the insertion of a drain.

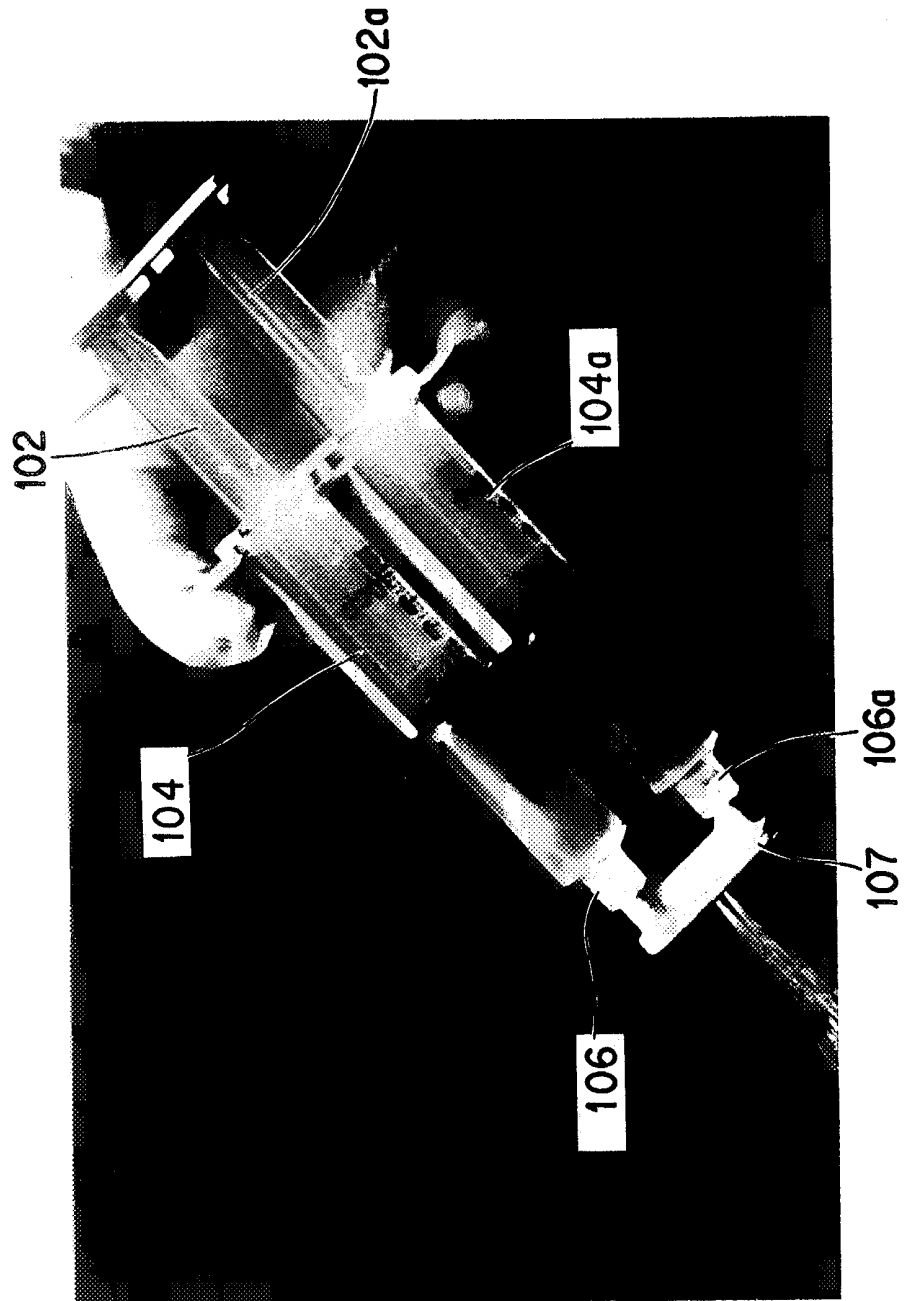

FIG. 1

FIG. 2

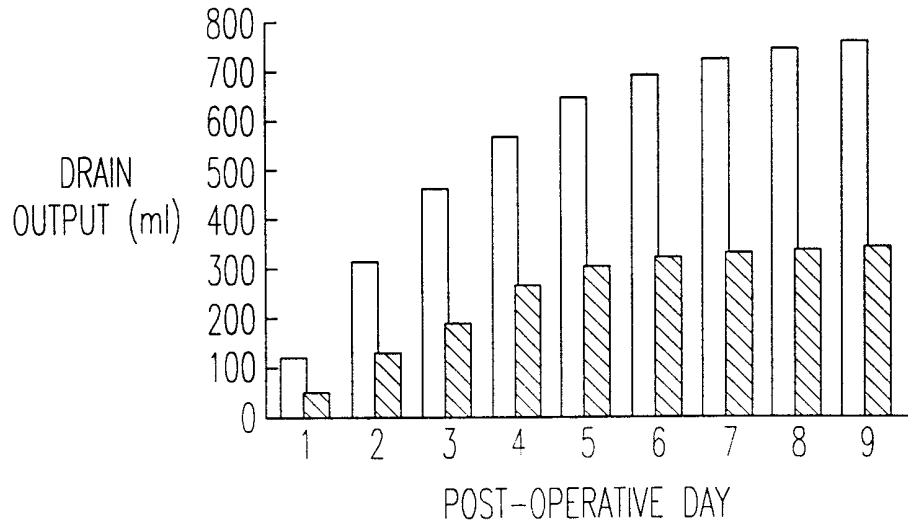
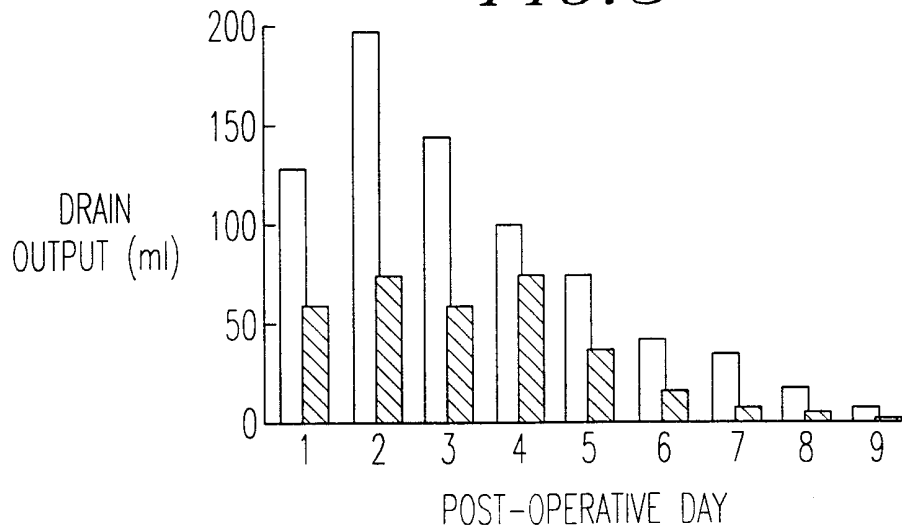

FIG. 3



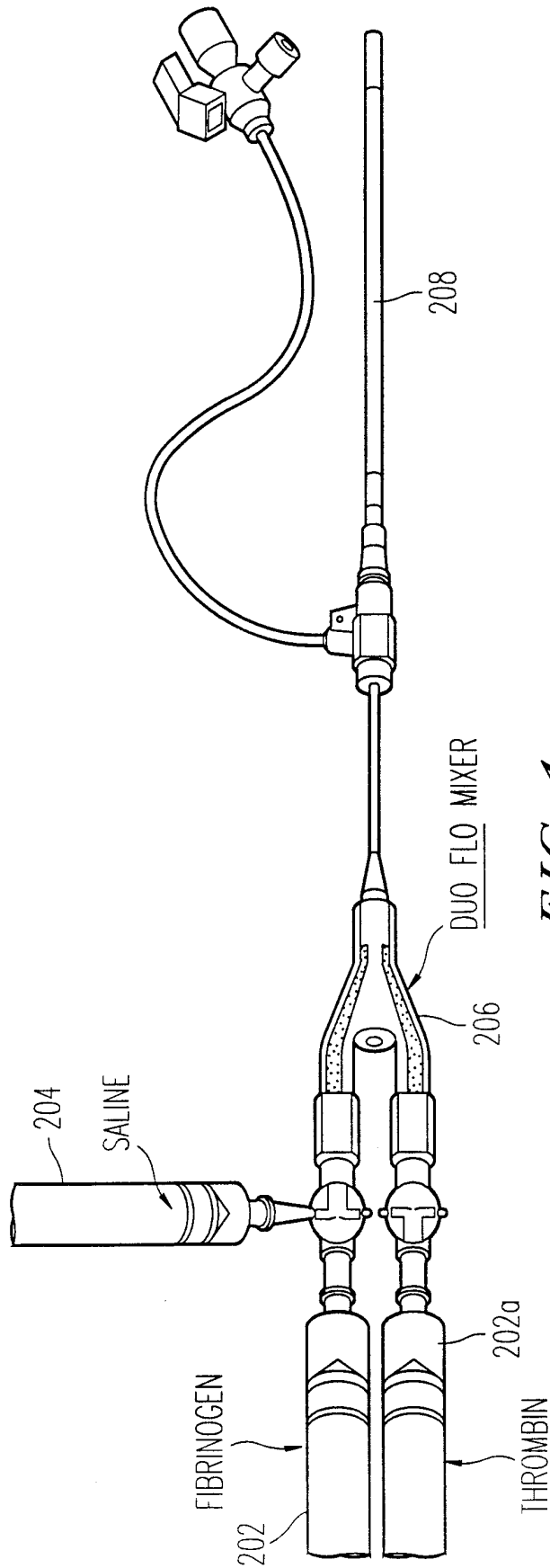

FIG. 4

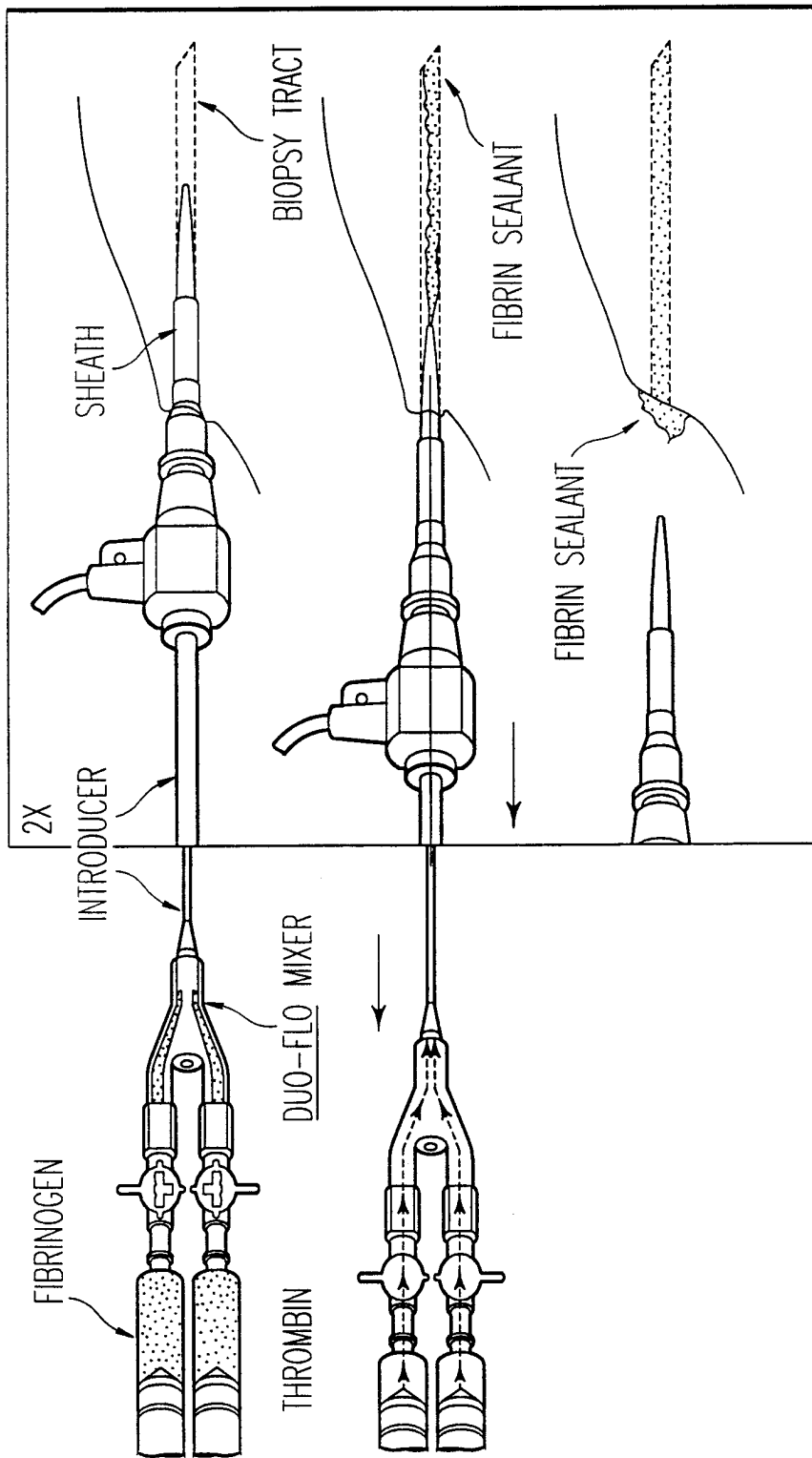

FIG. 5

INTERNATIONAL SEARCH REPORT

International application No.
PCT/US98/20928

A. CLASSIFICATION OF SUBJECT MATTER

IPC(6) : A61K 9/00
US CL : 128/898; 424/400; 604/82; 606/214, 216
According to International Patent Classification (IPC) or to both national classification and IPC

B. FIELDS SEARCHED

Minimum documentation searched (classification system followed by classification symbols)

U.S. : 606/216, 214; 424/400; 604/82; 128/898

Documentation searched other than minimum documentation to the extent that such documents are included in the fields searched

Electronic data base consulted during the international search (name of data base and, where practicable, search terms used)

C. DOCUMENTS CONSIDERED TO BE RELEVANT

Category*	Citation of document, with indication, where appropriate, of the relevant passages	Relevant to claim No.
X	US 5,631,011 A (WADSTROM) 20 May 1997, entire document.	1-3
Y	US 5,318,524 A (MORSE et al.) 07 June 1994, entire document.	3-18
Y, P	US 5,810,885 A (ZINGER) 22 September 1998, entire document.	3-18

Further documents are listed in the continuation of Box C. See patent family annex.

* Special categories of cited documents:	"T"	later document published after the international filing date or priority date and not in conflict with the application but cited to understand the principle or theory underlying the invention
"A" document defining the general state of the art which is not considered to be of particular relevance	"X"	document of particular relevance; the claimed invention cannot be considered novel or cannot be considered to involve an inventive step when the document is taken alone
"E" earlier document published on or after the international filing date	"Y"	document of particular relevance; the claimed invention cannot be considered to involve an inventive step when the document is combined with one or more other such documents, such combination being obvious to a person skilled in the art
"L" document which may throw doubts on priority claim(s) or which is cited to establish the publication date of another citation or other special reason (as specified)	"&"	document member of the same patent family
"O" document referring to an oral disclosure, use, exhibition or other means		
"P" document published prior to the international filing date but later than the priority date claimed		

Date of the actual completion of the international search
24 NOVEMBER 1998

Date of mailing of the international search report
24 DEC 1998

Name and mailing address of the ISA/US
Commissioner of Patents and Trademarks
Box PCT
Washington, D.C. 20231

Authorized officer *Vikki Trinh*
VIKKI TRINH

Facsimile No. (703) 305-3230

Telephone No. (703) 308-8238