



EUROPEAN PATENT APPLICATION

Application number : **94300104.0**

Int. Cl.⁵ : **F01D 5/02, F01D 5/30**

Date of filing : **07.01.94**

Priority : **03.02.93 GB 9302064**

Inventor : **Hirst, Roy Talbot**
11 Church Lane
Ticknall, Derby DE73 1JU (GB)
 Inventor : **Broadhead, Peter**
361 Uttoxeter Road
Mickleover, Derby DE21 2BU (GB)
 Inventor : **Halliwell, Mark**
13 Rye Close
Oakwood, Derby DE21 2BU (GB)

Date of publication of application :
10.08.94 Bulletin 94/32

Designated Contracting States :
DE FR GB

Representative : **Gunn, Michael Alan**
P.O. Box 31
Derby, DE24 8BJ (GB)

Applicant : **ROLLS-ROYCE PLC**
65 Buckingham Gate
London SW1E 6AT (GB)

54) Balanced rotor for a gas turbine engine.

57) A balanced rotor (21) for a gas turbine engine (10) comprises a disc (22) which carries an annular array of aerofoil blades (23). Each of said aerofoil blades (23) has a fir-tree root portion (27) which locates in a corresponding groove (28) in the disc (22). The blade root portions (27) are retained axially by retention plates (29) located in an annular array on the rotor (21) adjacent the root portions (27). A minority of the retention plates (29) are lighter than the remainder. The lighter plates (29) are so distributed around the rotor as to ensure the balance of the rotor (21).

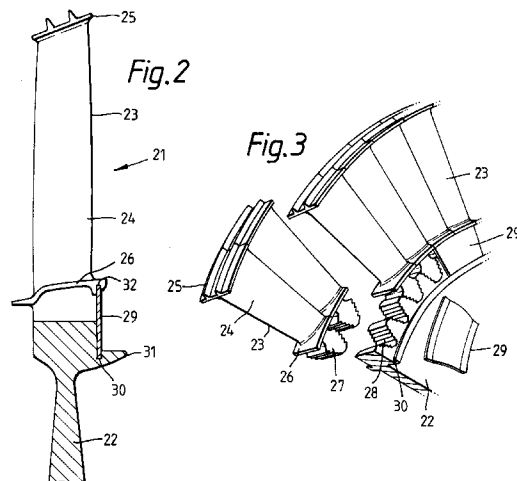

This invention relates to a balanced rotor which is suitable for use in a gas turbine engine.

Gas turbine engines commonly include an axial flow turbine having at least one rotor which comprises a disc, the radially outer periphery of which carries a plurality of aerofoil blades. Each aerofoil blade has a root portion, often of fir-tree type cross-sectional configuration, which locates in a correspondingly shaped, axially extending slot provided in the disc periphery.

It is virtually impossible to ensure that such a rotor is perfectly balanced without resorting to a balancing procedure in which small balance weights are attached to the rotor. Conventionally, therefore, the balance weights are attached to a suitable support structure which is itself either attached to the disc or is an integral part of the disc.

While the use of such balance weights is effective in achieving rotor balance, it does of course result in the rotor being more expensive to manufacture and slightly heavier than it would otherwise be the case were balancing not required.

It is an object of the present invention to provide a balanced rotor for a gas turbine engine which avoids these drawbacks.

According to the present invention, a balanced rotor suitable for a gas turbine engine comprises a disc carrying an annular array of radially extending aerofoil blades on its periphery, each of said blades having a root portion slidably located in a correspondingly shaped generally axially extending retention groove provided in said disc periphery, said rotor additionally including a plurality of generally similar retention plates so located thereon and attached thereto as to provide axial retention of said aerofoil blades on said disc, the majority of said plates being substantially equal in weight to each other, each of the remaining plates being of different weight to each of said plates in the majority, said plates of different weight being so distributed on said rotor as to ensure its balance.

The present invention will now be described, by way of example, with reference to the accompanying drawings in which:

Fig 1 is a schematic sectioned side view of a ducted fan gas turbine engine which incorporates a balanced rotor in accordance with the present invention.

Fig 2 is a sectioned side view of a portion of a balanced rotor in accordance with the present invention.

Fig 3 is a partially exploded view of a balanced rotor in accordance with the present invention.

Referring to Fig 1, a ducted fan gas turbine engine generally indicated at 10 is of conventional configuration. It comprises, in axial flow series, an air inlet 11, a fan 12 contained within a duct 13, an intermediate pressure compressor 14, a high pressure compressor 15, combustion equipment 16, high, intermediate and low pressure turbines 17, 18 and 19

respectively and an exhaust nozzle 20. The turbines 19, 18 and 17 respectively drive the fan 12, intermediate pressure compressor 14 and high pressure compressor 15 by concentric shafts extending along the central axis of the engine 10.

Air drawn in through the air inlet 11 by the fan 12 is divided into two flows. The first flow is exhausted from the fan duct 13 to provide propulsive thrust. The second flow is directed into the intermediate pressure compressor 14 where compression of the air takes place. The air is then directed into the high pressure compressor 15 where further compression of the air takes place before it is directed into the combustion equipment 16. There the air is mixed with fuel and the mixture combusted. The resultant hot gaseous combustion products then expand through, and thereby drive, the high, intermediate and low pressure turbines 17, 18 and 19 respectively. Finally, the combustion products are exhausted through the nozzle 20 to provide additional propulsive thrust.

The intermediate pressure turbine 18 includes a rotor 21, part of which can be seen more clearly if reference is now made to Figs 2 and 3. The rotor 21 comprises a disc 22 which carries an annular array of similar aerofoil blades 23. Each aerofoil blade 23 comprises an aerofoil portion 24 which is acted upon by the gaseous flow through the intermediate pressure turbine 18.

At the radially outer end of each aerofoil portion 24 there is provided a shroud 25. The shrouds 25 of adjacent aerofoil blades abut each other so that they cooperate to define an annular barrier to inhibit gas leakage over the radially outer extents of the blades 23.

At the radially inner end of each aerofoil blade 23 there is provided a platform 26. The platforms 26 of adjacent aerofoil blades cooperate to define an annular portion of the radially inner boundary of the gaseous flow through the intermediate pressure turbine 18.

Radially inwardly of each platform 26 there is provided a root 27 which is of the so-called fir-tree cross-section configuration. Each blade root 27 locates in a correspondingly shaped axially extending retention groove 28 provided in the periphery of the disc 22. A step (not shown) provided at one end of each groove 28 prevents axial movement of the aerofoil blades 23 in one axial direction. Movement in the opposite direction is prevented by a plurality of generally similar circumferentially arcuate retention plates 29. The retention plates 29 are arranged in an annular array to cover the ends of the blade roots 27. Each retention plate 29 is maintained in position on the disc 22 by its location in grooves provided in the disc 22 and the blade platforms 26. Specifically the radially inner edge of each retention plate 29 locates in a radially outwardly directed annular groove 30 provided in an annular axially extending flange 31 on the disc 22.

The radially outer edge of each retention plate 29 locates in a radially inwardly directed annular groove 32 defined by individual grooves in each blade platform 26.

The majority of the retention plates 29, for instance 36, are planar and can be readily manoeuvred into position in the grooves 30 and 32. This can be achieved, for instance, by leaving out some of the aerofoil blades 23 and sliding the retention plates 29 along the grooves 30 and 32. However the remainder of the retention plates 29 cannot be so positioned once all of the aerofoil blades 23 are correctly positioned on the disc 22. In order to circumvent this problem, the remaining retention plates 29, which may amount to nine plates, are not flat but are of slightly curved configuration as can be seen from the floating plate 29 shown in Fig 3. This slight curving of these retention plates 29 enables them to be positioned with their radially inner and outer edges adjacent the grooves 30 and 32. They are then flattened, by for instance hammering, so that their radially inner and outer edges enter and are engaged within the grooves 30 and 32.

Each of the retention plates is approximately 3 cms wide radially and 5 cms long circumferentially. Those retention plates 29 which are in the majority are approximately 1.5 mm thick. However the retention plates 29 which are in the minority, that is the slightly curved plates 29, are only 1 mm thick. They are, therefore slightly lighter than the majority of the retention plates 29. This feature of the thinner plates 29 is put to use in the balancing of the rotor 21.

After all of the thicker, flat retention plates 29 and all of the aerofoil blades 23 have been loaded on to the disc 22, the whole assembly is put on a suitable balancing machine. The slightly thinner retention plates 29 are then temporarily positioned on the disc 22, by for instance the use of adhesive tape. Balancing is then carried out; the retention plates 29 being moved around the disc 22 periphery until balance is achieved. The slightly thinner retention plates 29 are then fixed in their appropriate positions by being flattened as described earlier.

Although the retention plates 29 in the minority have been described as being slightly thinner than the remainder, it will be appreciated that this need not necessarily be the only way of achieving weight variation in the plates 29. Thus other material or configurational changes could be utilised. Moreover the retention plates 29 in the minority could be heavier, not lighter than the remaining plates 29.

The important feature of the retention plates 29 in the minority is that they should be of different weight to the majority of the retention plates 29 to permit the achievement of balance.

It will be seen therefore that the present invention provides a balanced rotor 21 without the need for the disc 22 to be adapted to carry dedicated balance

weights. Such adaptation increases manufacturing costs and adds undesirable weight to the whole rotor assembly 21.

Although the present invention has been described with reference to an intermediate pressure turbine rotor assembly 21, it will be appreciated that it may also be applied to other turbine rotor assemblies or indeed compressor rotor assemblies.

Claims

1. A balanced rotor (21) suitable for a gas turbine engine (10) comprising a disc (22) carrying an annular array of radially extending aerofoil blades (23) on its periphery, each of said blades (23) having a root portion (27) slidably located in a correspondingly shaped, generally axially extending retention groove (28) provided in said disc (22) periphery, said rotor (21) additionally including a plurality of generally similar retention plates (29) so located thereon and attached thereto as to provide axial retention of said aerofoil blades (23) on said disc (22), characterised in that the majority of said plates (29) are substantially equal in weight to each other, each of the remaining plates (29) being of different weight to each of said plates (29) in the majority, said plates (29) of different weight being so distributed on said rotor (21) as to ensure its balance.
2. A balanced rotor (21) as claimed in claim 1 characterised in that each of said retention plates (29) in the minority is lighter than each of said retention plates (29) in the majority.
3. A balanced rotor as claimed in claim 2 characterised in that each of said retention plates (29) in the minority is thinner than each of said retention plates (29) in the majority in order to ensure that each of said retention plates (29) in the minority is lighter than each of said retention plates (29) in the majority.
4. A balanced rotor as claimed in any one preceding claim characterised in that said retention plates (29) are disposed in an annular array on said rotor (21).
5. A balanced rotor as claimed in any one preceding claim characterised in that said retention plates (29) are located in radially directed grooves (30,32) defined in said disc and each of said aerofoil blades (23).
6. A balanced rotor as claimed in claim 5 characterised in that each of said aerofoil blades (23) is provided with a platform (26) adjacent to and ra-

dially outwardly of its root portion (27), said radially directed grooves (32) (30,32) in each of said blades (23) being provided in their platforms (26).

7. A balanced rotor (23) as claimed in claim 5 or claim 6 characterised in that said radially directed grooves (30,32) are annular about the longitudinal axis of said rotor. 5
8. A balanced rotor as claimed in claim 7 characterised in that said retention plates (29) in the minority are so configured as to be inserted in said annular grooves (30,32) after said retention plates (29) in the majority have been so inserted. 10
9. A balanced rotor as claimed in claim 8 characterised in that said retention plates (29) in the minority are initially curved to permit their insertion into said annular grooves (30,32). 15
10. A balanced rotor as claimed in any one preceding claim characterised in that each of said retention plates (29) in situ is generally planar and circumferentially arcuate. 20
11. A balanced rotor as claimed in any one preceding claim characterised in that each of said blade root portions (27) is of fir-tree configuration. 25

30

35

40

45

50

55

4

Fig.1

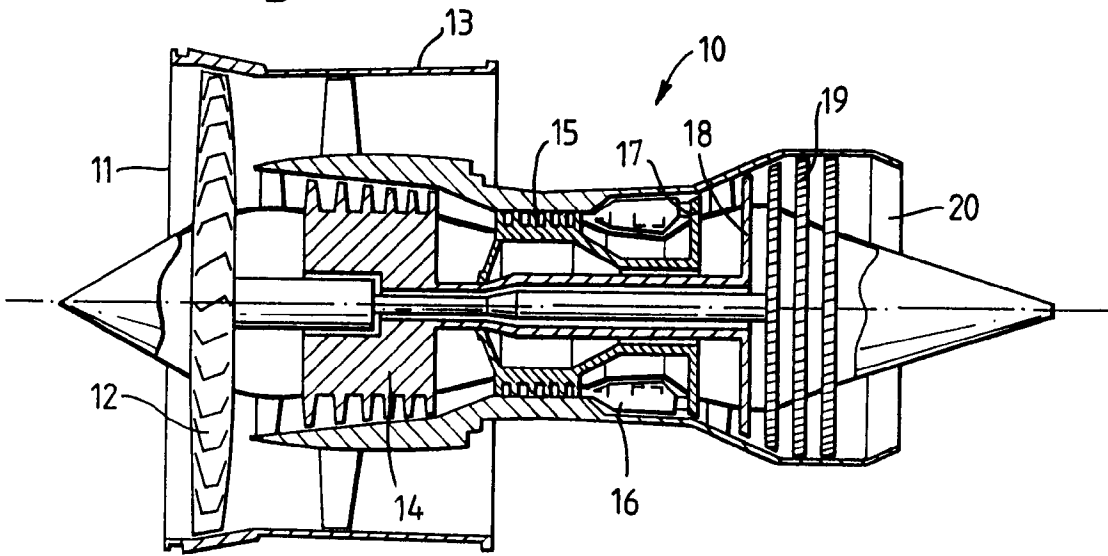

Fig.2

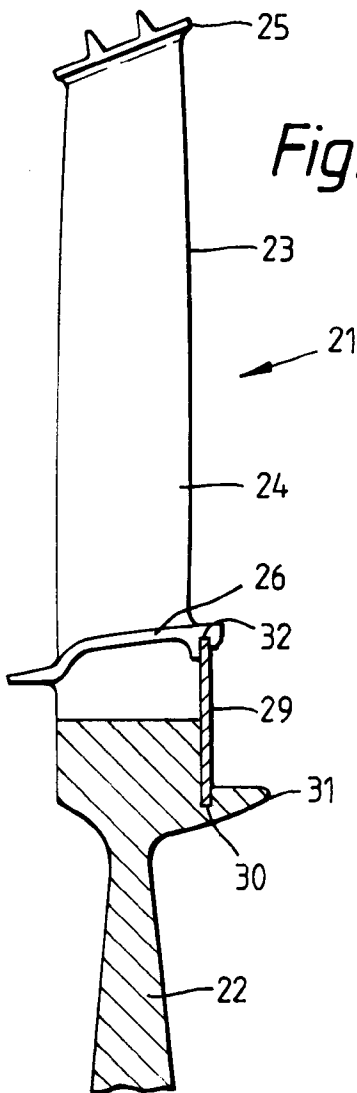
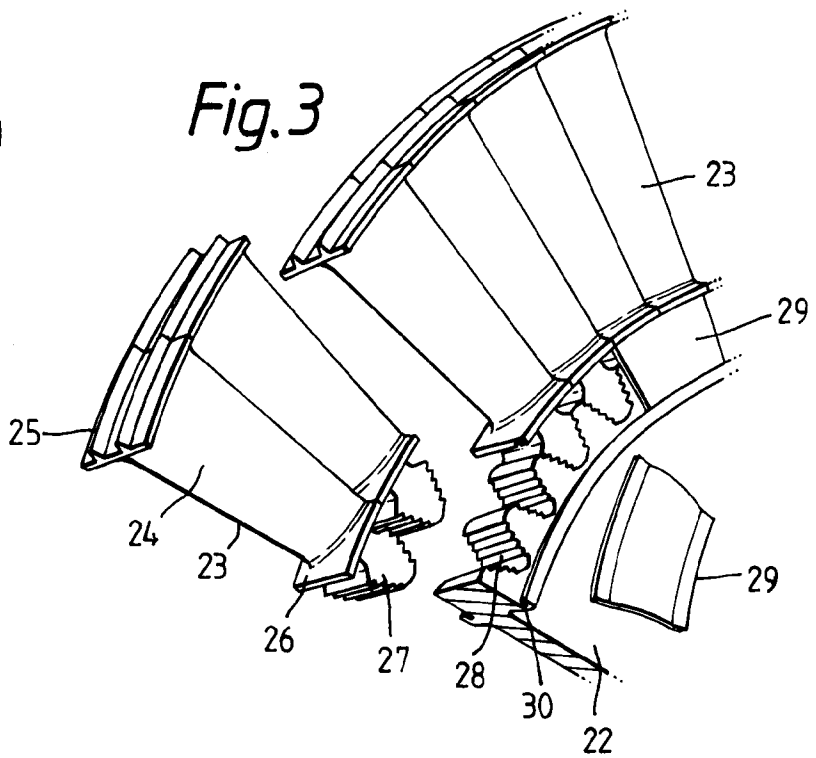

Fig.3





European Patent
Office

EUROPEAN SEARCH REPORT

Application Number
EP 94 30 0104

DOCUMENTS CONSIDERED TO BE RELEVANT			
Category	Citation of document with indication, where appropriate, of relevant passages	Relevant to claim	CLASSIFICATION OF THE APPLICATION (Int. Cl.5)
A	GB-A-2 105 790 (ROLLS-ROYCE LTD.) * abstract; figure 3 * ---	1	F01D5/02 F01D5/30
A	US-A-3 888 601 (GENERAL ELECTRIC COMPANY) * column 4, line 34 - column 5, line 12; figures * ---	1	
A	US-A-3 077 811 (NATIONAL RESEARCH COUNCIL, CANADA) * claim 1; figures * ---	1,9,10	
A	GB-A-1 095 830 (ROLLS-ROYCE LTD.) * page 2, line 52 - line 105; figures 2,4,5 * ---	1,4-10	
A	DE-A-19 28 184 (WESTINGHOUSE ELECTRIC CORPORATION) * claims 1-4,7; figures 1,3,4 * -----	1,4-8	
			TECHNICAL FIELDS SEARCHED (Int. Cl.5)
			F01D
The present search report has been drawn up for all claims			
Place of search THE HAGUE		Date of completion of the search 6 April 1994	Examiner SERRANO GALARRAGA, J
CATEGORY OF CITED DOCUMENTS		T : theory or principle underlying the invention E : earlier patent document, but published on, or after the filing date D : document cited in the application L : document cited for other reasons & : member of the same patent family, corresponding document	
X : particularly relevant if taken alone Y : particularly relevant if combined with another document of the same category A : technological background O : non-written disclosure P : intermediate document			

EPO FORM 1503 01.92 (F04C01)