

(12) INTERNATIONAL APPLICATION PUBLISHED UNDER THE PATENT COOPERATION TREATY (PCT)

(19) World Intellectual Property
Organization
International Bureau



(10) International Publication Number
WO 2020/209669 A1

(43) International Publication Date
15 October 2020 (15.10.2020)

(51) International Patent Classification:

H04W 74/00 (2009.01) H04W 72/12 (2009.01)
H04W 74/08 (2009.01)

(21) International Application Number:

PCT/KR2020/004900

(22) International Filing Date:

10 April 2020 (10.04.2020)

(25) Filing Language:

English

(26) Publication Language:

English

(30) Priority Data:

10-2019-0042519 11 April 2019 (11.04.2019) KR
10-2019-0042526 11 April 2019 (11.04.2019) KR
10-2019-0042536 11 April 2019 (11.04.2019) KR

(71) Applicant: **LG ELECTRONICS INC.** [KR/KR]; 128, Yeoui-daero, Yeongdeungpo-gu, Seoul 07336 (KR).

(72) Inventors: **LEE, Eunjong**; IP Center, LG Electronics Inc., 19, Yangjae-daero 11-gil, Seocho-gu, Seoul 06772 (KR). **LEE, Jeonggu**; IP Center, LG Electronics Inc., 19, Yangjae-daero 11-gil, Seocho-gu, Seoul 06772 (KR). **YI, Seungjune**; IP Center, LG Electronics Inc., 19, Yangjae-daero 11-gil, Seocho-gu, Seoul 06772 (KR). **LEE, Sunyoung**; IP Center, LG Electronics Inc., 19, Yangjae-daero 11-gil, Seocho-gu, Seoul 06772 (KR).

(74) Agent: **KBK & ASSOCIATES**; (Jamsil Hyundae Building 7th Floor), 82, Olympic-ro, Songpa-gu, Seoul 05556 (KR).

(81) Designated States (unless otherwise indicated, for every kind of national protection available): AE, AG, AL, AM, AO, AT, AU, AZ, BA, BB, BG, BH, BN, BR, BW, BY, BZ, CA, CH, CL, CN, CO, CR, CU, CZ, DE, DJ, DK, DM, DO, DZ, EC, EE, EG, ES, FI, GB, GD, GE, GH, GM, GT, HN, HR, HU, ID, IL, IN, IR, IS, JO, JP, KE, KG, KH, KN, KP, KR, KW, KZ, LA, LC, LK, LR, LS, LU, LY, MA, MD, ME, MG, MK, MN, MW, MX, MY, MZ, NA, NG, NI, NO, NZ, OM, PA, PE, PG, PH, PL, PT, QA, RO, RS, RU, RW, SA, SC, SD, SE, SG, SK, SL, ST, SV, SY, TH, TJ, TM, TN, TR, TT, TZ, UA, UG, US, UZ, VC, VN, WS, ZA, ZM, ZW.

(84) Designated States (unless otherwise indicated, for every kind of regional protection available): ARIPO (BW, GH, GM, KE, LR, LS, MW, MZ, NA, RW, SD, SL, ST, SZ, TZ,

UG, ZM, ZW), Eurasian (AM, AZ, BY, KG, KZ, RU, TJ, TM), European (AL, AT, BE, BG, CH, CY, CZ, DE, DK, EE, ES, FI, FR, GB, GR, HR, HU, IE, IS, IT, LT, LU, LV, MC, MK, MT, NL, NO, PL, PT, RO, RS, SE, SI, SK, SM, TR), OAPI (BF, BJ, CF, CG, CI, CM, GA, GN, GQ, GW, KM, ML, MR, NE, SN, TD, TG).

Published:

— with international search report (Art. 21(3))



WO 2020/209669 A1

(54) Title: METHOD OF PERFORMING RANDOM ACCESS PROCEDURE, AND TRANSMITTING DEVICE, APPARATUS AND STORAGE MEDIUM THEREFOR

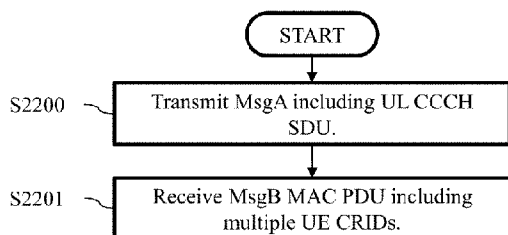

(57) Abstract: In the present disclosure, a UE transmits a random access preamble (RAP) on a physical random access channel (PRACH) and a control channel (CCCH) service data unit (SDU) on a physical uplink shared channel (PUSCH); and receives a medium access control (MAC) protocol data unit (PDU) based on transmitting the RAP and the CCCH SDU. The MAC PDU includes a first part, and a second part after the first part. The first part includes multiple UE contention resolution identities (UE CRIDs).

Description

Title of Invention: METHOD OF PERFORMING RANDOM ACCESS PROCEDURE, AND TRANSMITTING DEVICE, APPARATUS AND STORAGE MEDIUM THEREFOR

Technical Field

- [1] The present invention relates to a wireless communication system.

Background Art

- [2] Introduction of new radio communication technologies has led to increases in the number of user equipments (UEs) to which a base station (BS) provides services in a prescribed resource region, and has also led to increases in the amount of data and control information that the BS transmits to the UEs. Due to typically limited resources available to the BS for communication with the UE(s), new techniques are needed by which the BS utilizes the limited radio resources to efficiently receive/transmit uplink/downlink data and/or uplink/downlink control information.

Disclosure of Invention

Technical Problem

- [3] Various types of signals, including data signals and control signals, are communicated via uplink (UL) and downlink (DL). Scheduling of such communications is typically performed, to achieve improved efficiency, latency, and/or reliability. Overcoming delay or latency has become an important challenge in applications whose performance critically depends on delay/latency.
- [4] The technical objects that can be achieved through the present invention are not limited to what has been particularly described hereinabove and other technical objects not described herein will be more clearly understood by persons skilled in the art from the following detailed description.

Solution to Problem

- [5] As an aspect of the present disclosure, provided herein is a method for performing a random access (RA) procedure by a user equipment (UE) in a wireless communication system. The method comprises: transmitting a random access preamble (RAP) on a physical random access channel (PRACH) and a control channel (CCCH) service data unit (SDU) on a physical uplink shared channel (PUSCH); and receiving a medium access control (MAC) protocol data unit (PDU) based on transmitting the RAP and the CCCH SDU. The MAC PDU includes a first part, and a second part after the first part, and the first part includes multiple UE contention resolution identities (UE CRIDs).
- [6] As another aspect of the present disclosure, provided herein is a user equipment (UE)

of performing a random access (RA) procedure in a wireless communication system. The UE comprises: at least one transceiver; at least one processor; and at least one computer memory storing instructions which, when executed, cause the at least one processor to perform operations. The operations comprise: transmitting a random access preamble (RAP) on a physical random access channel (PRACH) and a control channel (CCCH) service data unit (SDU) on a physical uplink shared channel (PUSCH); and receiving a medium access control (MAC) protocol data unit (PDU) based on transmitting the RAP and the CCCH SDU. The MAC PDU includes a first part, and a second part after the first part, and the first part includes multiple UE contention resolution identities (UE CRIDs).

[7] As a further aspect of the present disclosure, provided herein is an apparatus for a user equipment (UE). The apparatus comprises: at least one processor; and at least one computer memory storing instructions which, when executed, cause the at least one processor to perform operations. The operations comprise: transmitting a random access preamble (RAP) on a physical random access channel (PRACH) and a control channel (CCCH) service data unit (SDU) on a physical uplink shared channel (PUSCH); and receiving a medium access control (MAC) protocol data unit (PDU) based on transmitting the RAP and the CCCH SDU. The MAC PDU includes a first part, and a second part after the first part, and the first part includes multiple UE contention resolution identities (UE CRIDs).

[8] As a still further aspect of the present disclosure, provided herein is a computer readable storage medium storing at least one program that include instructions which, when executed, cause the at least one processor to perform operations. The operations comprise: transmitting a random access preamble (RAP) on a physical random access channel (PRACH) and a control channel (CCCH) service data unit (SDU) on a physical uplink shared channel (PUSCH); and receiving a medium access control (MAC) protocol data unit (PDU) based on transmitting the RAP and the CCCH SDU. The MAC PDU includes a first part, and a second part after the first part, and the first part includes multiple UE contention resolution identities (UE CRIDs).

[9] In each aspect of the present disclosure, the second part may include respective timing advance commands for the multiple UE CRIDs.

[10] In each aspect of the present disclosure, the method or operations may further comprise: determining whether the multiple UE CRIDs include a UE CRID matching the CCCH SDU, and processing a timing advance command corresponding to the UE CRID based on determining that the multiple UE CRIDs include the UE CRID matching the CCCH SDU.

[11] In each aspect of the present disclosure, the MAC PDU may include a UE CRID MAC control element (CE). The multiple UE CRIDs may be included in the UE CRID

MAC CE.

[12] In each aspect of the present disclosure, the MAC PDU may further include a MAC subheader for the UE CRID MAC CE. The MAC subheader may include a logical channel identity (LCID) field set to a value representing the UE CRID MAC CE that includes the multiple UE CRIDs.

[13] In each aspect of the present disclosure, the MAC subheader may include a length field set to a value indicating the size of the UE CRID MAC CE.

[14] The above technical solutions are merely some parts of the implementations of the present disclosure and various implementations into which the technical features of the present disclosure are incorporated can be derived and understood by persons skilled in the art from the following detailed description of the present disclosure.

Advantageous Effects of Invention

[15] In some scenarios, implementations of the present disclosure may provide one or more of the following advantages. In some scenarios, radio communication signals can be more efficiently transmitted and/or received. Therefore, overall throughput of a radio communication system can be improved.

[16] According to some implementations of the present disclosure, delay/latency occurring during communication between a user equipment and a BS may be reduced.

[17] Also, signals in a new radio access technology system can be transmitted and/or received more effectively.

[18] It will be appreciated by persons skilled in the art that the effects that can be achieved through the present disclosure are not limited to what has been particularly described hereinabove and other advantages of the present disclosure will be more clearly understood from the following detailed description.

Brief Description of Drawings

[19] The accompanying drawings, which are included to provide a further understanding of the invention, illustrate embodiments of the invention and together with the description serve to explain the principle of the invention:

[20] FIG. 1 illustrates an example of a communication system 1 to which implementations of the present disclosure is applied;

[21] FIG. 2 is a block diagram illustrating examples of communication devices which can perform a method according to the present disclosure;

[22] FIG. 3 illustrates another example of a wireless device which can perform implementations of the present invention;

[23] FIG. 4 illustrates an example of protocol stacks in a third generation partnership project (3GPP) based wireless communication system;

[24] FIG. 5 illustrates an example of a frame structure in a 3GPP based wireless commu-

- nication system;
- [25] FIG. 6 illustrates a data flow example in the 3GPP new radio (NR) system;
- [26] FIG. 7 and FIG. 8 illustrate examples of random access procedures in the 3GPP based system;
- [27] FIG. 9 illustrates examples of medium access control (MAC) protocol data unit (PDU);
- [28] FIG. 10 illustrates examples of MAC subheader related to random access response (RAR);
- [29] FIG. 11 illustrates examples of MAC subheader used in a MAC PDU for downlink shared channel (DL-SCH) and uplink shared channel (UL-SCH);
- [30] FIG. 12 illustrates examples of flow diagrams of the 2-step RACH procedure in some implementations of the present disclosure;
- [31] FIG. 13 illustrates an example of a RAR MAC PDU for a fallback from a 2-step RACH to a 4-step RACH in some implementations of the present disclosure;
- [32] FIG. 14 illustrates examples of random access (RA) retry which may occur during the random access procedures;
- [33] FIG. 15 illustrates an example of a MAC PDU including multiple MsgBs;
- [34] FIG. 16 illustrates an example of a long UE CRID MAC CE according to some implementations of the present disclosure;
- [35] FIG. 17 illustrates an example of a MAC PDU including the long UE CRID MAC CE;
- [36] FIG. 18 illustrates an example of MsgB reception at a UE side according to some implementations of the present disclosure;
- [37] FIG. 19 illustrates an example of decoding of an MsgB MAC PDU according to some implementations of the present disclosure;
- [38] FIG. 20 illustrates another example of long UE CRID MAC CE according to some implementations of the present disclosure;
- [39] FIG. 21 illustrates another example of a MAC PDU including the long UE CRID MAC CE;
- [40] FIG. 22 illustrates an example of a flow diagram for a random access procedure according to some implementations of the present disclosure;
- [41] FIG. 23 illustrates an example of PDSCH time domain resource allocation by PDCCH, and an example of PUSCH time resource allocation by PDCCH; and
- [42] FIG. 24 illustrates an example of physical layer processing for some implementations of the present disclosure.

Mode for the Invention

- [43] Reference will now be made in detail to the exemplary implementations of the

present disclosure, examples of which are illustrated in the accompanying drawings. The detailed description, which will be given below with reference to the accompanying drawings, is intended to explain exemplary implementations of the present disclosure, rather than to show the only implementations that can be implemented according to the disclosure. The following detailed description includes specific details in order to provide a thorough understanding of the present disclosure. However, it will be apparent to those skilled in the art that the present disclosure may be practiced without such specific details.

[44] The following techniques, apparatuses, and systems may be applied to a variety of wireless multiple access systems. Examples of the multiple access systems include a code division multiple access (CDMA) system, a frequency division multiple access (FDMA) system, a time division multiple access (TDMA) system, an orthogonal frequency division multiple access (OFDMA) system, a single carrier frequency division multiple access (SC-FDMA) system, and a multicarrier frequency division multiple access (MC-FDMA) system. CDMA may be embodied through radio technology such as universal terrestrial radio access (UTRA) or CDMA2000. TDMA may be embodied through radio technology such as global system for mobile communications (GSM), general packet radio service (GPRS), or enhanced data rates for GSM evolution (EDGE). OFDMA may be embodied through radio technology such as institute of electrical and electronics engineers (IEEE) 802.11 (Wi-Fi), IEEE 802.16 (WiMAX), IEEE 802.20, or evolved UTRA (E-UTRA). UTRA is a part of a universal mobile telecommunications system (UMTS). 3rd generation partnership project (3GPP) long term evolution (LTE) is a part of evolved UMTS (E-UMTS) using E-UTRA. 3GPP LTE employs OFDMA in DL and SC-FDMA in UL. LTE-advanced (LTE-A) is an evolved version of 3GPP LTE.

[45] For convenience of description, implementations of the present disclosure are mainly described in regards to a 3GPP based wireless communication system. However, the technical features of the present disclosure are not limited thereto. For example, although the following detailed description is given based on a mobile communication system corresponding to a 3GPP based wireless communication system, aspects of the present disclosure that are not limited to 3GPP based wireless communication system are applicable to other mobile communication systems.

[46] For terms and technologies which are not specifically described among the terms of and technologies employed in the present disclosure, the wireless communication standard documents published before the present disclosure may be referenced. For example, the following documents may be referenced.

[47] 3GPP LTE

[48] - 3GPP TS 36.211: Physical channels and modulation

- [49] - 3GPP TS 36.212: Multiplexing and channel coding
- [50] - 3GPP TS 36.213: Physical layer procedures
- [51] - 3GPP TS 36.214: Physical layer; Measurements
- [52] - 3GPP TS 36.300: Overall description
- [53] - 3GPP TS 36.304: User Equipment (UE) procedures in idle mode
- [54] - 3GPP TS 36.314: Layer 2 - Measurements
- [55] - 3GPP TS 36.321: Medium Access Control (MAC) protocol
- [56] - 3GPP TS 36.322: Radio Link Control (RLC) protocol
- [57] - 3GPP TS 36.323: Packet Data Convergence Protocol (PDCP)
- [58] - 3GPP TS 36.331: Radio Resource Control (RRC) protocol
- [59] 3GPP NR (e.g. 5G)
- [60] - 3GPP TS 38.211: Physical channels and modulation
- [61] - 3GPP TS 38.212: Multiplexing and channel coding
- [62] - 3GPP TS 38.213: Physical layer procedures for control
- [63] - 3GPP TS 38.214: Physical layer procedures for data
- [64] - 3GPP TS 38.215: Physical layer measurements
- [65] - 3GPP TS 38.300: Overall description
- [66] - 3GPP TS 38.304: User Equipment (UE) procedures in idle mode and in RRC inactive state
- [67] - 3GPP TS 38.321: Medium Access Control (MAC) protocol
- [68] - 3GPP TS 38.322: Radio Link Control (RLC) protocol
- [69] - 3GPP TS 38.323: Packet Data Convergence Protocol (PDCP)
- [70] - 3GPP TS 38.331: Radio Resource Control (RRC) protocol
- [71] - 3GPP TS 37.324: Service Data Adaptation Protocol (SDAP)
- [72] - 3GPP TS 37.340: Multi-connectivity; Overall description
- [73] In the present disclosure, a user equipment (UE) may be a fixed or mobile device.

Examples of the UE include various devices that transmit and receive user data and/or various kinds of control information to and from a base station (BS). In the present disclosure, a BS generally refers to a fixed station that performs communication with a UE and/or another BS, and exchanges various kinds of data and control information with the UE and another BS. The BS may be referred to as an advanced base station (ABS), a node-B (NB), an evolved node-B (eNB), a base transceiver system (BTS), an access point (AP), a processing server (PS), etc. Especially, a BS of the UMTS is referred to as a NB, a BS of the enhanced packet core (EPC) / long term evolution (LTE) system is referred to as an eNB, and a BS of the new radio (NR) system is referred to as a gNB.

- [74] In the present disclosure, a node refers to a point capable of transmitting/receiving a radio signal through communication with a UE. Various types of BSs may be used as

nodes irrespective of the terms thereof. For example, a BS, a node B (NB), an e-node B (eNB), a pico-cell eNB (PeNB), a home eNB (HeNB), a relay, a repeater, etc. may be a node. In addition, the node may not be a BS. For example, the node may be a radio remote head (RRH) or a radio remote unit (RRU). The RRH or RRU generally has a lower power level than a power level of a BS. Since the RRH or RRU (hereinafter, RRH/RRU) is generally connected to the BS through a dedicated line such as an optical cable, cooperative communication between RRH/RRU and the BS can be smoothly performed in comparison with cooperative communication between BSs connected by a radio line. At least one antenna is installed per node. The antenna may include a physical antenna or an antenna port or a virtual antenna.

[75] In the present disclosure, the term "cell" may refer to a geographic area to which one or more nodes provide a communication system, or refer to radio resources. A "cell" of a geographic area may be understood as coverage within which a node can provide service using a carrier and a "cell" as radio resources (e.g. time-frequency resources) is associated with bandwidth (BW) which is a frequency range configured by the carrier. The "cell" associated with the radio resources is defined by a combination of downlink resources and uplink resources, for example, a combination of a downlink (DL) component carrier (CC) and an uplink (UL) CC. The cell may be configured by downlink resources only, or may be configured by downlink resources and uplink resources. Since DL coverage, which is a range within which the node is capable of transmitting a valid signal, and UL coverage, which is a range within which the node is capable of receiving the valid signal from the UE, depends upon a carrier carrying the signal, the coverage of the node may be associated with coverage of the "cell" of radio resources used by the node. Accordingly, the term "cell" may be used to represent service coverage of the node sometimes, radio resources at other times, or a range that signals using the radio resources can reach with valid strength at other times.

[76] In the present disclosure, a physical downlink control channel (PDCCH), and a physical downlink shared channel (PDSCH) refer to a set of time-frequency resources or resource elements (REs) carrying downlink control information (DCI), and a set of time-frequency resources or REs carrying downlink data, respectively. In addition, a physical uplink control channel (PUCCH), a physical uplink shared channel (PUSCH) and a physical random access channel (PRACH) refer to a set of time-frequency resources or REs carrying uplink control information (UCI), a set of time-frequency resources or REs carrying uplink data and a set of time-frequency resources or REs carrying random access signals, respectively.

[77] In the present disclosure, the term "cell" may refer to a geographic area to which one or more nodes provide a communication system, or refer to radio resources. A "cell" of a geographic area may be understood as coverage within which a node can provide

service using a carrier and a "cell" as radio resources (e.g. time-frequency resources) is associated with bandwidth (BW) which is a frequency range configured by the carrier. The "cell" associated with the radio resources is defined by a combination of downlink resources and uplink resources, for example, a combination of a downlink (DL) component carrier (CC) and an uplink (UL) CC. The cell may be configured by downlink resources only, or may be configured by downlink resources and uplink resources. Since DL coverage, which is a range within which the node is capable of transmitting a valid signal, and UL coverage, which is a range within which the node is capable of receiving the valid signal from the UE, depends upon a carrier carrying the signal, the coverage of the node may be associated with coverage of the "cell" of radio resources used by the node. Accordingly, the term "cell" may be used to represent service coverage of the node sometimes, radio resources at other times, or a range that signals using the radio resources can reach with valid strength at other times.

[78] In carrier aggregation (CA), two or more CCs are aggregated. A UE may simultaneously receive or transmit on one or multiple CCs depending on its capabilities. CA is supported for both contiguous and non-contiguous CCs. When CA is configured the UE only has one radio resource control (RRC) connection with the network. At RRC connection establishment/re-establishment/handover, one serving cell provides the non-access stratum (NAS) mobility information, and at RRC connection re-establishment/handover, one serving cell provides the security input. This cell is referred to as the Primary Cell (PCell). The PCell is a cell, operating on the primary frequency, in which the UE either performs the initial connection establishment procedure or initiates the connection re-establishment procedure. Depending on UE capabilities, Secondary Cells (SCells) can be configured to form together with the PCell a set of serving cells. An SCell is a cell providing additional radio resources on top of Special Cell. The configured set of serving cells for a UE therefore always consists of one PCell and one or more SCells. In the present disclosure, for dual connectivity (DC) operation, the term "special Cell" refers to the PCell of the master cell group (MCG) or the PSCell of the secondary cell group (SCG), and otherwise the term Special Cell refers to the PCell. An SpCell supports physical uplink control channel (PUCCH) transmission and contention-based random access, and is always activated. The MCG is a group of serving cells associated with a master node, comprising of the SpCell (PCell) and optionally one or more SCells. The SCG is the subset of serving cells associated with a secondary node, comprising of the PSCell and zero or more SCells, for a UE configured with DC. For a UE in RRC_CONNECTED not configured with CA/DC there is only one serving cell comprising of the PCell. For a UE in RRC_CONNECTED configured with CA/DC the term "serving cells" is used to denote the set of cells comprising of the SpCell(s) and all SCells.

- [79] The MCG is a group of serving cells associated with a master BS which terminates at least S1-MME, and the SCG is a group of serving cells associated with a secondary BS that is providing additional radio resources for the UE but is not the master BS. The SCG includes a primary SCell (PSCell) and optionally one or more SCells. In DC, two MAC entities are configured in the UE: one for the MCG and one for the SCG. Each MAC entity is configured by RRC with a serving cell supporting PUCCH transmission and contention based Random Access. In the present disclosure, the term SpCell refers to such cell, whereas the term SCell refers to other serving cells. The term SpCell either refers to the PCell of the MCG or the PSCell of the SCG depending on if the MAC entity is associated to the MCG or the SCG, respectively.
- [80] In the present disclosure, monitoring a channel refers to attempting to decode the channel. For example, monitoring a physical downlink control channel (PDCCH) refers to attempting to decode PDCCH(s) (or PDCCH candidates).
- [81] In the present disclosure, "C-RNTI" refers to a cell RNTI, "SI-RNTI" refers to a system information RNTI, "P-RNTI" refers to a paging RNTI, "RA-RNTI" refers to a random access RNTI, "SC-RNTI" refers to a single cell RNTI, "SL-RNTI" refers to a sidelink RNTI, "SPS C-RNTI" refers to a semi-persistent scheduling C-RNTI, and "CS-RNTI" refers to a configured scheduling RNTI.
- [82] FIG. 1 illustrates an example of a communication system 1 to which implementations of the present disclosure is applied.
- [83] Three main requirement categories for 5G include (1) a category of enhanced mobile broadband (eMBB), (2) a category of massive machine type communication (mMTC), and (3) a category of ultra-reliable and low latency communications (URLLC).
- [84] Partial use cases may require a plurality of categories for optimization and other use cases may focus only upon one key performance indicator (KPI). 5G supports such various use cases using a flexible and reliable method.
- [85] eMBB far surpasses basic mobile Internet access and covers abundant bidirectional work and media and entertainment applications in cloud and augmented reality. Data is one of 5G core motive forces and, in a 5G era, a dedicated voice service may not be provided for the first time. In 5G, it is expected that voice will be simply processed as an application program using data connection provided by a communication system. Main causes for increased traffic volume are due to an increase in the size of content and an increase in the number of applications requiring high data transmission rate. A streaming service (of audio and video), conversational video, and mobile Internet access will be more widely used as more devices are connected to the Internet. These many application programs require connectivity of an always turned-on state in order to push real-time information and alarm for users. Cloud storage and applications are rapidly increasing in a mobile communication platform and may be applied to both

work and entertainment. The cloud storage is a special use case which accelerates growth of uplink data transmission rate. 5G is also used for remote work of cloud. When a tactile interface is used, 5G demands much lower end-to-end latency to maintain user good experience. Entertainment, for example, cloud gaming and video streaming, is another core element which increases demand for mobile broadband capability. Entertainment is essential for a smartphone and a tablet in any place including high mobility environments such as a train, a vehicle, and an airplane. Other use cases are augmented reality for entertainment and information search. In this case, the augmented reality requires very low latency and instantaneous data volume.

[86] In addition, one of the most expected 5G use cases relates a function capable of smoothly connecting embedded sensors in all fields, i.e., mMTC. It is expected that the number of potential IoT devices will reach 204 hundred million up to the year of 2020. An industrial IoT is one of categories of performing a main role enabling a smart city, asset tracking, smart utility, agriculture, and security infrastructure through 5G.

[87] URLLC includes a new service that will change industry through remote control of main infrastructure and an ultra-reliable/available low-latency link such as a self-driving vehicle. A level of reliability and latency is essential to control a smart grid, automatize industry, achieve robotics, and control and adjust a drone.

[88] 5G is a means of providing streaming evaluated as a few hundred megabits per second to gigabits per second and may complement fiber-to-the-home (FTTH) and cable-based broadband (or DOCSIS). Such fast speed is needed to deliver TV in resolution of 4K or more (6K, 8K, and more), as well as virtual reality and augmented reality. Virtual reality (VR) and augmented reality (AR) applications include almost immersive sports games. A specific application program may require a special network configuration. For example, for VR games, gaming companies need to incorporate a core server into an edge network server of a network operator in order to minimize latency.

[89] Automotive is expected to be a new important motivated force in 5G together with many use cases for mobile communication for vehicles. For example, entertainment for passengers requires high simultaneous capacity and mobile broadband with high mobility. This is because future users continue to expect connection of high quality regardless of their locations and speeds. Another use case of an automotive field is an AR dashboard. The AR dashboard causes a driver to identify an object in the dark in addition to an object seen from a front window and displays a distance from the object and a movement of the object by overlapping information talking to the driver. In the future, a wireless module enables communication between vehicles, information exchange between a vehicle and supporting infrastructure, and information exchange between a vehicle and other connected devices (e.g., devices accompanied by a

pedestrian). A safety system guides alternative courses of a behavior so that a driver may drive more safely drive, thereby lowering the danger of an accident. The next stage will be a remotely controlled or self-driven vehicle. This requires very high reliability and very fast communication between different self-driven vehicles and between a vehicle and infrastructure. In the future, a self-driven vehicle will perform all driving activities and a driver will focus only upon abnormal traffic that the vehicle cannot identify. Technical requirements of a self-driven vehicle demand ultra-low latency and ultra-high reliability so that traffic safety is increased to a level that cannot be achieved by human being.

- [90] A smart city and a smart home/building mentioned as a smart society will be embedded in a high-density wireless sensor network. A distributed network of an intelligent sensor will identify conditions for costs and energy-efficient maintenance of a city or a home. Similar configurations may be performed for respective households. All of temperature sensors, window and heating controllers, burglar alarms, and home appliances are wirelessly connected. Many of these sensors are typically low in data transmission rate, power, and cost. However, real-time HD video may be demanded by a specific type of device to perform monitoring.
- [91] Consumption and distribution of energy including heat or gas is distributed at a higher level so that automated control of the distribution sensor network is demanded. The smart grid collects information and connects the sensors to each other using digital information and communication technology so as to act according to the collected information. Since this information may include behaviors of a supply company and a consumer, the smart grid may improve distribution of fuels such as electricity by a method having efficiency, reliability, economic feasibility, production sustainability, and automation. The smart grid may also be regarded as another sensor network having low latency.
- [92] Mission critical application (e.g. e-health) is one of 5G use scenarios. A health part contains many application programs capable of enjoying benefit of mobile communication. A communication system may support remote treatment that provides clinical treatment in a faraway place. Remote treatment may aid in reducing a barrier against distance and improve access to medical services that cannot be continuously available in a faraway rural area. Remote treatment is also used to perform important treatment and save lives in an emergency situation. The wireless sensor network based on mobile communication may provide remote monitoring and sensors for parameters such as heart rate and blood pressure.
- [93] Wireless and mobile communication gradually becomes important in the field of an industrial application. Wiring is high in installation and maintenance cost. Therefore, a possibility of replacing a cable with reconstructible wireless links is an attractive op-

portunity in many industrial fields. However, in order to achieve this replacement, it is necessary for wireless connection to be established with latency, reliability, and capacity similar to those of the cable and management of wireless connection needs to be simplified. Low latency and a very low error probability are new requirements when connection to 5G is needed.

- [94] Logistics and freight tracking are important use cases for mobile communication that enables inventory and package tracking anywhere using a location-based information system. The use cases of logistics and freight typically demand low data rate but require location information with a wide range and reliability.
- [95] Referring to FIG. 1, the communication system 1 includes wireless devices, base stations (BSs), and a network. Although FIG. 1 illustrates a 5G network as an example of the network of the communication system 1, the implementations of the present disclosure are not limited to the 5G system, and can be applied to the future communication system beyond the 5G system.
- [96] The BSs and the network may be implemented as wireless devices and a specific wireless device 200a may operate as a BS/network node with respect to other wireless devices.
- [97] The wireless devices represent devices performing communication using radio access technology (RAT) (e.g., 5G New RAT (NR)) or Long-Term Evolution (LTE)) and may be referred to as communication/radio/5G devices. The wireless devices may include, without being limited to, a robot 100a, vehicles 100b-1 and 100b-2, an eXtended Reality (XR) device 100c, a hand-held device 100d, a home appliance 100e, an Internet of Things (IoT) device 100f, and an Artificial Intelligence (AI) device/server 400. For example, the vehicles may include a vehicle having a wireless communication function, an autonomous driving vehicle, and a vehicle capable of performing communication between vehicles. The vehicles may include an Unmanned Aerial Vehicle (UAV) (e.g., a drone). The XR device may include an Augmented Reality (AR)/Virtual Reality (VR)/Mixed Reality (MR) device and may be implemented in the form of a Head-Mounted Device (HMD), a Head-Up Display (HUD) mounted in a vehicle, a television, a smartphone, a computer, a wearable device, a home appliance device, a digital signage, a vehicle, a robot, etc. The hand-held device may include a smartphone, a smartpad, a wearable device (e.g., a smartwatch or a smartglasses), and a computer (e.g., a notebook). The home appliance may include a TV, a refrigerator, and a washing machine. The IoT device may include a sensor and a smartmeter.
- [98] In the present disclosure, the wireless devices 100a to 100f may be called user equipments (UEs). A user equipment (UE) may include, for example, a cellular phone, a smartphone, a laptop computer, a digital broadcast terminal, a personal digital assistant (PDA), a portable multimedia player (PMP), a navigation system, a slate

personal computer (PC), a tablet PC, an ultrabook, a vehicle, a vehicle having an autonomous traveling function, a connected car, an unmanned aerial vehicle (UAV), an artificial intelligence (AI) module, a robot, an augmented reality (AR) device, a virtual reality (VR) device, a mixed reality (MR) device, a hologram device, a public safety device, an MTC device, an IoT device, a medical device, a FinTech device (or a financial device), a security device, a weather/environment device, a device related to a 5G service, or a device related to a fourth industrial revolution field. The unmanned aerial vehicle (UAV) may be, for example, an aircraft aviated by a wireless control signal without a human being onboard. The VR device may include, for example, a device for implementing an object or a background of the virtual world. The AR device may include, for example, a device implemented by connecting an object or a background of the virtual world to an object or a background of the real world. The MR device may include, for example, a device implemented by merging an object or a background of the virtual world into an object or a background of the real world. The hologram device may include, for example, a device for implementing a stereoscopic image of 360 degrees by recording and reproducing stereoscopic information, using an interference phenomenon of light generated when two laser lights called holography meet. The public safety device may include, for example, an image relay device or an image device that is wearable on the body of a user. The MTC device and the IoT device may be, for example, devices that do not require direct human intervention or manipulation. For example, the MTC device and the IoT device may include smartmeters, vending machines, thermometers, smartbulbs, door locks, or various sensors. The medical device may be, for example, a device used for the purpose of diagnosing, treating, relieving, curing, or preventing disease. For example, the medical device may be a device used for the purpose of diagnosing, treating, relieving, or correcting injury or impairment. For example, the medical device may be a device used for the purpose of inspecting, replacing, or modifying a structure or a function. For example, the medical device may be a device used for the purpose of adjusting pregnancy. For example, the medical device may include a device for treatment, a device for operation, a device for (in vitro) diagnosis, a hearing aid, or a device for procedure. The security device may be, for example, a device installed to prevent a danger that may arise and to maintain safety. For example, the security device may be a camera, a CCTV, a recorder, or a black box. The FinTech device may be, for example, a device capable of providing a financial service such as mobile payment. For example, the FinTech device may include a payment device or a point of sales (POS) system. The weather/environment device may include, for example, a device for monitoring or predicting a weather/environment.

[99] The wireless devices 100a to 100f may be connected to the network 300 via the BSs

200. An AI technology may be applied to the wireless devices 100a to 100f and the wireless devices 100a to 100f may be connected to the AI server 400 via the network 300. The network 300 may be configured using a 3G network, a 4G (e.g., LTE) network, a 5G (e.g., NR) network, and a beyond-5G network. Although the wireless devices 100a to 100f may communicate with each other through the BSs 200/network 300, the wireless devices 100a to 100f may perform direct communication (e.g., sidelink communication) with each other without passing through the BSs/network. For example, the vehicles 100b-1 and 100b-2 may perform direct communication (e.g. Vehicle-to-Vehicle (V2V)/Vehicle-to-everything (V2X) communication). The IoT device (e.g., a sensor) may perform direct communication with other IoT devices (e.g., sensors) or other wireless devices 100a to 100f.

[100] Wireless communication/connections 150a and 150b may be established between the wireless devices 100a to 100f/BS 200-BS 200. Herein, the wireless communication/connections may be established through various RATs (e.g., 5G NR) such as uplink/downlink communication 150a and sidelink communication 150b (or D2D communication). The wireless devices and the BSs/the wireless devices may transmit/receive radio signals to/from each other through the wireless communication/connections 150a and 150b. For example, the wireless communication/connections 150a and 150b may transmit/receive signals through various physical channels. To this end, at least a part of various configuration information configuring processes, various signal processing processes (e.g., channel encoding/decoding, modulation/demodulation, and resource mapping/demapping), and resource allocating processes, for transmitting/receiving radio signals, may be performed based on the various proposals of the present disclosure.

[101] FIG. 2 is a block diagram illustrating examples of communication devices which can perform a method according to the present disclosure.

[102] Referring to FIG. 2, a first wireless device 100 and a second wireless device 200 may transmit/receive radio signals to/from an external device through a variety of RATs (e.g., LTE and NR). In FIG. 2, {the first wireless device 100 and the second wireless device 200} may correspond to {the wireless device 100a to 100f and the BS 200} and/or {the wireless device 100a to 100f and the wireless device 100a to 100f} of FIG. 1.

[103] The first wireless device 100 may include one or more processors 102 and one or more memories 104 and additionally further include one or more transceivers 106 and/or one or more antennas 108. The processor(s) 102 may control the memory(s) 104 and/or the transceiver(s) 106 and may be configured to implement the functions, procedures, and/or methods described in the present disclosure. For example, the processor(s) 102 may process information within the memory(s) 104 to generate first

information/signals and then transmit radio signals including the first information/signals through the transceiver(s) 106. The processor(s) 102 may receive radio signals including second information/signals through the transceiver 106 and then store information obtained by processing the second information/signals in the memory(s) 104. The memory(s) 104 may be connected to the processor(s) 102 and may store a variety of information related to operations of the processor(s) 102. For example, the memory(s) 104 may store software code including commands for performing a part or the entirety of processes controlled by the processor(s) 102 or for performing the procedures and/or methods described in the present disclosure. Herein, the processor(s) 102 and the memory(s) 104 may be a part of a communication modem/circuit/chip designed to implement RAT (e.g., LTE or NR). The transceiver(s) 106 may be connected to the processor(s) 102 and transmit and/or receive radio signals through one or more antennas 108. Each of the transceiver(s) 106 may include a transmitter and/or a receiver. The transceiver(s) 106 may be interchangeably used with radio frequency (RF) unit(s). In the present invention, the wireless device may represent a communication modem/circuit/chip.

[104] The second wireless device 200 may include one or more processors 202 and one or more memories 204 and additionally further include one or more transceivers 206 and/or one or more antennas 208. The processor(s) 202 may control the memory(s) 204 and/or the transceiver(s) 206 and may be configured to implement the functions, procedures, and/or methods described in the present disclosure. For example, the processor(s) 202 may process information within the memory(s) 204 to generate third information/signals and then transmit radio signals including the third information/signals through the transceiver(s) 206. The processor(s) 202 may receive radio signals including fourth information/signals through the transceiver(s) 106 and then store information obtained by processing the fourth information/signals in the memory(s) 204. The memory(s) 204 may be connected to the processor(s) 202 and may store a variety of information related to operations of the processor(s) 202. For example, the memory(s) 204 may store software code including commands for performing a part or the entirety of processes controlled by the processor(s) 202 or for performing the procedures and/or methods described in the present disclosure. Herein, the processor(s) 202 and the memory(s) 204 may be a part of a communication modem/circuit/chip designed to implement RAT (e.g., LTE or NR). The transceiver(s) 206 may be connected to the processor(s) 202 and transmit and/or receive radio signals through one or more antennas 208. Each of the transceiver(s) 206 may include a transmitter and/or a receiver. The transceiver(s) 206 may be interchangeably used with RF unit(s). In the present invention, the wireless device may represent a communication modem/circuit/chip.

[105] Hereinafter, hardware elements of the wireless devices 100 and 200 will be described more specifically. One or more protocol layers may be implemented by, without being limited to, one or more processors 102 and 202. For example, the one or more processors 102 and 202 may implement one or more layers (e.g., functional layers such as PHY, MAC, RLC, PDCP, RRC, and SDAP). The one or more processors 102 and 202 may generate one or more Protocol Data Units (PDUs) and/or one or more Service Data Unit (SDUs) according to the functions, procedures, proposals, and/or methods disclosed in the present disclosure. The one or more processors 102 and 202 may generate messages, control information, data, or information according to the functions, procedures, proposals, and/or methods disclosed in the present disclosure. The one or more processors 102 and 202 may generate signals (e.g., baseband signals) including PDUs, SDUs, messages, control information, data, or information according to the functions, procedures, proposals, and/or methods disclosed in the present disclosure and provide the generated signals to the one or more transceivers 106 and 206. The one or more processors 102 and 202 may receive the signals (e.g., baseband signals) from the one or more transceivers 106 and 206 and acquire the PDUs, SDUs, messages, control information, data, or information according to the functions, procedures, proposals, and/or methods disclosed in the present disclosure.

[106] The one or more processors 102 and 202 may be referred to as controllers, microcontrollers, microprocessors, or microcomputers. The one or more processors 102 and 202 may be implemented by hardware, firmware, software, or a combination thereof. As an example, one or more Application Specific Integrated Circuits (ASICs), one or more Digital Signal Processors (DSPs), one or more Digital Signal Processing Devices (DSPDs), one or more Programmable Logic Devices (PLDs), or one or more Field Programmable Gate Arrays (FPGAs) may be included in the one or more processors 102 and 202. The functions, procedures, proposals, and/or methods disclosed in the present disclosure may be implemented using firmware or software and the firmware or software may be configured to include the modules, procedures, or functions. Firmware or software configured to perform the functions, procedures, proposals, and/or methods disclosed in the present disclosure may be included in the one or more processors 102 and 202 or stored in the one or more memories 104 and 204 so as to be driven by the one or more processors 102 and 202. The functions, procedures, proposals, and/or methods disclosed in the present disclosure may be implemented using firmware or software in the form of code, commands, and/or a set of commands.

[107] The one or more memories 104 and 204 may be connected to the one or more processors 102 and 202 and store various types of data, signals, messages, information, programs, code, instructions, and/or commands. The one or more memories 104 and 204 may be configured by Read-Only Memories (ROMs), Random Access Memories

(RAMs), Electrically Erasable Programmable Read-Only Memories (EPROMs), flash memories, hard drives, registers, cash memories, computer-readable storage media, and/or combinations thereof. The one or more memories 104 and 204 may be located at the interior and/or exterior of the one or more processors 102 and 202. The one or more memories 104 and 204 may be connected to the one or more processors 102 and 202 through various technologies such as wired or wireless connection.

[108] The one or more transceivers 106 and 206 may transmit user data, control information, and/or radio signals/channels, mentioned in the methods and/or operational flowcharts of the present disclosure, to one or more other devices. The one or more transceivers 106 and 206 may receive user data, control information, and/or radio signals/channels, mentioned in the functions, procedures, proposals, methods, and/or operational flowcharts disclosed in the present disclosure, from one or more other devices. For example, the one or more transceivers 106 and 206 may be connected to the one or more processors 102 and 202 and transmit and receive radio signals. For example, the one or more processors 102 and 202 may perform control so that the one or more transceivers 106 and 206 may transmit user data, control information, or radio signals to one or more other devices. The one or more processors 102 and 202 may perform control so that the one or more transceivers 106 and 206 may receive user data, control information, or radio signals from one or more other devices. The one or more transceivers 106 and 206 may be connected to the one or more antennas 108 and 208 and the one or more transceivers 106 and 206 may be configured to transmit and receive user data, control information, and/or radio signals/channels, mentioned in the functions, procedures, proposals, methods, and/or operational flowcharts disclosed in the present disclosure, through the one or more antennas 108 and 208. In the present disclosure, the one or more antennas may be a plurality of physical antennas or a plurality of logical antennas (e.g., antenna ports). The one or more transceivers 106 and 206 may convert received radio signals/channels etc. from RF band signals into baseband signals in order to process received user data, control information, radio signals/channels, etc. using the one or more processors 102 and 202. The one or more transceivers 106 and 206 may convert the user data, control information, radio signals/channels, etc. processed using the one or more processors 102 and 202 from the baseband signals into the RF band signals. To this end, the one or more transceivers 106 and 206 may include (analog) oscillators and/or filters. For example, the transceivers 106 and 206 can up-convert OFDM baseband signals to a carrier frequency by their (analog) oscillators and/or filters under the control of the processors 102 and 202 and transmit the up-converted OFDM signals at the carrier frequency. The transceivers 106 and 206 may receive OFDM signals at a carrier frequency and down-convert the OFDM signals into OFDM baseband signals by their (analog) oscillators and/or filters

under the control of the transceivers 102 and 202.

[109] In the present disclosure, at least one memory (e.g. 104 or 204) may store instructions or programs that, when executed, cause at least one processor, which is operably connected thereto, to perform operations according to some embodiments or implementations of the present disclosure.

[110] In the present disclosure, a computer readable storage medium may store at least one instruction or computer program that, when executed by at least one processor, causes the at least one processor to perform operations according to some embodiments or implementations of the present disclosure.

[111] In the present disclosure, a processing device or apparatus may comprise at least one processor, and at least one computer memory connectable to the at least one processor and storing instructions that, when executed, cause the at least one processor to perform operations according to some embodiments or implementations of the present disclosure.

[112] In some implementations of the present disclosure, a UE may operate as a transmitting device in uplink (UL) and as a receiving device in downlink (DL). In some implementations of the present disclosure, a BS may operate as a receiving device in UL and as a transmitting device in DL. Hereinafter, for convenience of description, it is mainly assumed that the first wireless device 100 acts as the UE, and the second wireless device 200 acts as the BS, unless otherwise mentioned or described. For example, the processor(s) 102 connected to, mounted on or launched in the first wireless device 100 may be configured to perform the UE behaviour according to an implementation of the present disclosure or control the transceiver(s) 106 to perform the UE behaviour according to an implementation of the present disclosure. The processor(s) 202 connected to, mounted on or launched in the second wireless device 200 may be configured to perform the BS behaviour according to an implementation of the present disclosure or control the transceiver(s) 206 to perform the BS behaviour according to an implementation of the present disclosure.

[113] FIG. 3 illustrates another example of a wireless device which can perform implementations of the present invention. The wireless device may be implemented in various forms according to a use-case/service (refer to FIG. 1).

[114] Referring to FIG. 3, wireless devices 100 and 200 may correspond to the wireless devices 100 and 200 of FIG. 2 and may be configured by various elements, components, units/portions, and/or modules. For example, each of the wireless devices 100 and 200 may include a communication unit 110, a control unit 120, a memory unit 130, and additional components 140. The communication unit may include a communication circuit 112 and transceiver(s) 114. For example, the communication circuit 112 may include the one or more processors 102 and 202 of FIG. 2 and/or the one or

more memories 104 and 204 of FIG. 2. For example, the transceiver(s) 114 may include the one or more transceivers 106 and 206 of FIG. 2 and/or the one or more antennas 108 and 208 of FIG. 2. The control unit 120 is electrically connected to the communication unit 110, the memory 130, and the additional components 140 and controls overall operation of the wireless devices. For example, the control unit 120 may control an electric/mechanical operation of the wireless device based on programs/code/commands/information stored in the memory unit 130. The control unit 120 may transmit the information stored in the memory unit 130 to the exterior (e.g., other communication devices) via the communication unit 110 through a wireless/wired interface or store, in the memory unit 130, information received through the wireless/wired interface from the exterior (e.g., other communication devices) via the communication unit 110.

[115] The additional components 140 may be variously configured according to types of wireless devices. For example, the additional components 140 may include at least one of a power unit/battery, input/output (I/O) unit (e.g. audio I/O port, video I/O port), a driving unit, and a computing unit. The wireless device may be implemented in the form of, without being limited to, the robot (100a of FIG. 1), the vehicles (100b-1 and 100b-2 of FIG. 1), the XR device (100c of FIG. 1), the hand-held device (100d of FIG. 1), the home appliance (100e of FIG. 1), the IoT device (100f of FIG. 1), a digital broadcast terminal, a hologram device, a public safety device, an MTC device, a medicine device, a Fintech device (or a finance device), a security device, a climate/environment device, the AI server/device (400 of FIG. 1), the BSs (200 of FIG. 1), a network node, etc. The wireless device may be used in a mobile or fixed place according to a use-example/service.

[116] In FIG. 3, the entirety of the various elements, components, units/portions, and/or modules in the wireless devices 100 and 200 may be connected to each other through a wired interface or at least a part thereof may be wirelessly connected through the communication unit 110. For example, in each of the wireless devices 100 and 200, the control unit 120 and the communication unit 110 may be connected by wire and the control unit 120 and first units (e.g., 130 and 140) may be wirelessly connected through the communication unit 110. Each element, component, unit/portion, and/or module within the wireless devices 100 and 200 may further include one or more elements. For example, the control unit 120 may be configured by a set of one or more processors. As an example, the control unit 120 may be configured by a set of a communication control processor, an application processor, an electronic control unit (ECU), a graphical processing unit, and a memory control processor. As another example, the memory 130 may be configured by a random access memory (RAM), a dynamic RAM (DRAM), a read only memory (ROM)), a flash memory, a volatile

memory, a non-volatile memory, and/or a combination thereof.

[117] FIG. 4 illustrates an example of protocol stacks in a 3GPP based wireless communication system.

[118] In particular, FIG. 4(a) illustrates an example of a radio interface user plane protocol stack between a UE and a base station (BS) and FIG. 4(b) illustrates an example of a radio interface control plane protocol stack between a UE and a BS. The control plane refers to a path through which control messages used to manage call by a UE and a network are transported. The user plane refers to a path through which data generated in an application layer, for example, voice data or Internet packet data are transported. Referring to FIG. 4(a), the user plane protocol stack may be divided into a first layer (Layer 1) (i.e., a physical (PHY) layer) and a second layer (Layer 2). Referring to FIG. 4(b), the control plane protocol stack may be divided into Layer 1 (i.e., a PHY layer), Layer 2, Layer 3 (e.g., a radio resource control (RRC) layer), and a non-access stratum (NAS) layer. Layer 1, Layer 2 and Layer 3 are referred to as an access stratum (AS).

[119] The NAS control protocol is terminated in an access management function (AMF) on the network side, and performs functions such as authentication, mobility management, security control and etc.

[120] In the 3GPP LTE system, the layer 2 is split into the following sublayers: medium access control (MAC), radio link control (RLC), and packet data convergence protocol (PDCP). In the 3GPP New Radio (NR) system, the layer 2 is split into the following sublayers: MAC, RLC, PDCP and SDAP. The PHY layer offers to the MAC sublayer transport channels, the MAC sublayer offers to the RLC sublayer logical channels, the RLC sublayer offers to the PDCP sublayer RLC channels, the PDCP sublayer offers to the SDAP sublayer radio bearers. The SDAP sublayer offers to 5G Core Network quality of service (QoS) flows.

[121] In the 3GPP NR system, the main services and functions of SDAP include: mapping between a QoS flow and a data radio bearer; marking QoS flow ID (QFI) in both DL and UL packets. A single protocol entity of SDAP is configured for each individual PDU session.

[122] In the 3GPP NR system, the main services and functions of the RRC sublayer include: broadcast of system information related to AS and NAS; paging initiated by 5G core (5GC) or NG-RAN; establishment, maintenance and release of an RRC connection between the UE and NG-RAN; security functions including key management; establishment, configuration, maintenance and release of signaling radio bearers (SRBs) and data radio bearers (DRBs); mobility functions (including: handover and context transfer; UE cell selection and reselection and control of cell selection and reselection; Inter-RAT mobility); QoS management functions; UE measurement reporting and control of the reporting; detection of and recovery from radio link

failure; NAS message transfer to/from NAS from/to UE.

[123] In the 3GPP NR system, the main services and functions of the PDCP sublayer for the user plane include: sequence numbering; header compression and decompression: ROHC only; transfer of user data; reordering and duplicate detection; in-order delivery; PDCP PDU routing (in case of split bearers); retransmission of PDCP SDUs; ciphering, deciphering and integrity protection; PDCP SDU discard; PDCP re-establishment and data recovery for RLC AM; PDCP status reporting for RLC AM; duplication of PDCP PDUs and duplicate discard indication to lower layers. The main services and functions of the PDCP sublayer for the control plane include: sequence numbering; ciphering, deciphering and integrity protection; transfer of control plane data; reordering and duplicate detection; in-order delivery; duplication of PDCP PDUs and duplicate discard indication to lower layers.

[124] The RLC sublayer supports three transmission modes: Transparent Mode (TM); Unacknowledged Mode (UM); and Acknowledged Mode (AM). The RLC configuration is per logical channel with no dependency on numerologies and/or transmission durations. In the 3GPP NR system, the main services and functions of the RLC sublayer depend on the transmission mode and include: Transfer of upper layer PDUs; sequence numbering independent of the one in PDCP (UM and AM); error correction through ARQ (AM only); segmentation (AM and UM) and re-segmentation (AM only) of RLC SDUs; reassembly of SDU (AM and UM); duplicate detection (AM only); RLC SDU discard (AM and UM); RLC re-establishment; protocol error detection (AM only).

[125] In the 3GPP NR system, the main services and functions of the MAC sublayer include: mapping between logical channels and transport channels; multiplexing/demultiplexing of MAC SDUs belonging to one or different logical channels into/from transport blocks (TB) delivered to/from the physical layer on transport channels; scheduling information reporting; error correction through hybrid automatic repeat request (HARQ) (one HARQ entity per cell in case of carrier aggregation (CA)); priority handling between UEs by means of dynamic scheduling; priority handling between logical channels of one UE by means of logical channel prioritization; padding. A single MAC entity may support multiple numerologies, transmission timings and cells. Mapping restrictions in logical channel prioritization control which numerology(ies), cell(s), and transmission timing(s) a logical channel can use. Different kinds of data transfer services are offered by MAC. To accommodate different kinds of data transfer services, multiple types of logical channels are defined i.e. each supporting transfer of a particular type of information. Each logical channel type is defined by what type of information is transferred. Logical channels are classified into two groups: Control Channels and Traffic Channels. Control channels

are used for the transfer of control plane information only, and traffic channels are used for the transfer of user plane information only. Broadcast Control Channel (BCCH) is a downlink logical channel for broadcasting system control information, paging Control Channel (PCCH) is a downlink logical channel that transfers paging information, system information change notifications and indications of ongoing PWS broadcasts, Common Control Channel (CCCH) is a logical channel for transmitting control information between UEs and network and used for UEs having no RRC connection with the network, and Dedicated Control Channel (DCCH) is a point-to-point bi-directional logical channel that transmits dedicated control information between a UE and the network and used by UEs having an RRC connection. Dedicated Traffic Channel (DTCH) is a point-to-point logical channel, dedicated to one UE, for the transfer of user information. A DTCH can exist in both uplink and downlink. In Downlink, the following connections between logical channels and transport channels exist: BCCH can be mapped to BCH; BCCH can be mapped to downlink shared channel (DL-SCH); PCCH can be mapped to PCH; CCCH can be mapped to DL-SCH; DCCH can be mapped to DL-SCH; and DTCH can be mapped to DL-SCH. In Uplink, the following connections between logical channels and transport channels exist: CCCH can be mapped to uplink shared channel (UL-SCH); DCCH can be mapped to UL-SCH; and DTCH can be mapped to UL-SCH.

[126] FIG. 5 illustrates an example of a frame structure in a 3GPP based wireless communication system.

[127] The frame structure illustrated in FIG. 5 is purely exemplary and the number of subframes, the number of slots, and/or the number of symbols in a frame may be variously changed. In the 3GPP based wireless communication system, OFDM numerologies (e.g., subcarrier spacing (SCS), transmission time interval (TTI) duration) may be differently configured between a plurality of cells aggregated for one UE. For example, if a UE is configured with different SCSs for cells aggregated for the cell, an (absolute time) duration of a time resource (e.g. a subframe, a slot, or a TTI) including the same number of symbols may be different among the aggregated cells. Herein, symbols may include OFDM symbols (or CP-OFDM symbols), SC-FDMA symbols (or discrete Fourier transform-spread-OFDM (DFT-s-OFDM) symbols).

[128] Referring to FIG. 5, downlink and uplink transmissions are organized into frames. Each frame has $T_f = 10$ ms duration. Each frame is divided into two half-frames, where each of the half-frames has 5 ms duration. Each half-frame consists of 5 subframes, where the duration T_{sf} per subframe is 1 ms. Each subframe is divided into slots and the number of slots in a subframe depends on a subcarrier spacing. Each slot includes 14 or 12 OFDM symbols based on a cyclic prefix (CP). In a normal CP, each slot includes 14 OFDM symbols and, in an extended CP, each slot includes 12 OFDM

symbols. The numerology is based on exponentially scalable subcarrier spacing $\Delta f = 2^u * 15$ kHz. The following table shows the number of OFDM symbols per slot, the number of slots per frame, and the number of slots per for the normal CP, according to the subcarrier spacing $\Delta f = 2^u * 15$ kHz.

[129] [Table 1]

u	$N_{\text{symb}}^{\text{slot}}$	$N_{\text{slot}}^{\text{frame},u}$	$N_{\text{slot}}^{\text{subframe},u}$
0	14	10	1
1	14	20	2
2	14	40	4
3	14	80	8
4	14	160	16

[130] The following table shows the number of OFDM symbols per slot, the number of slots per frame, and the number of slots per for the extended CP, according to the subcarrier spacing $\Delta f = 2^u * 15$ kHz.

[131] [Table 2]

u	$N_{\text{symb}}^{\text{slot}}$	$N_{\text{slot}}^{\text{frame},u}$	$N_{\text{slot}}^{\text{subframe},u}$
2	12	40	4

[132] A slot includes plural symbols (e.g., 14 or 12 symbols) in the time domain. For each numerology (e.g. subcarrier spacing) and carrier, a resource grid of $N_{\text{grid},x}^{\text{size},u} * N_{\text{sc}}^{\text{RB}}$ subcarriers and $N_{\text{symb}}^{\text{subframe},u}$ OFDM symbols is defined, starting at common resource block (CRB) $N_{\text{grid}}^{\text{start},u}$ indicated by higher-layer signaling (e.g. radio resource control (RRC) signaling), where $N_{\text{grid},x}^{\text{size},u}$ is the number of resource blocks in the resource grid and the subscript x is DL for downlink and UL for uplink. $N_{\text{sc}}^{\text{RB}}$ is the number of subcarriers per resource blocks. In the 3GPP based wireless communication system, $N_{\text{sc}}^{\text{RB}}$ is 12 generally. There is one resource grid for a given antenna port p , subcarrier spacing configuration u , and transmission direction (DL or UL). The carrier bandwidth $N_{\text{grid}}^{\text{size},u}$ for subcarrier spacing configuration u is given by the higher-layer parameter (e.g. RRC parameter). Each element in the resource grid for the antenna port p and the subcarrier spacing configuration u is referred to as a resource element (RE) and one complex symbol may be mapped to each RE. Each RE in the resource grid is uniquely identified by an index k in the frequency domain and an index l representing a symbol location relative to a reference point in the time domain. In the 3GPP based wireless communication system, a resource block is defined by 12 consecutive subcarriers in the frequency domain.

[133] In the 3GPP NR system, resource blocks are classified into CRBs and physical resource blocks (PRBs). CRBs are numbered from 0 and upwards in the frequency domain for subcarrier spacing configuration u . The center of subcarrier 0 of CRB 0 for subcarrier spacing configuration u coincides with 'point A' which serves as a common reference point for resource block grids. In the 3GPP NR system, PRBs are defined

within a bandwidth part (BWP) and numbered from 0 to $N_{\text{BWP},i}^{\text{size}}-1$, where i is the number of the bandwidth part. The relation between the physical resource block n_{PRB} in the bandwidth part i and the common resource block n_{CRB} is as follows: $n_{\text{PRB}} = n_{\text{CRB}} + N_{\text{BWP},i}^{\text{size}}$, where $N_{\text{BWP},i}^{\text{size}}$ is the common resource block where bandwidth part starts relative to CRB 0. The BWP includes a plurality of consecutive resource blocks. A carrier may include a maximum of N (e.g., 5) BWPs. A UE may be configured with one or more BWPs on a given component carrier. Only one BWP among BWPs configured to the UE can active at a time. The active BWP defines the UE's operating bandwidth within the cell's operating bandwidth.

[134] NR frequency bands are defined as 2 types of frequency range, FR1 and FR2. FR2 is may be also called millimeter wave (mmW). The frequency ranges in which NR can operate are identified as described in Table 3.

[135] [Table 3]

Frequency Range designation	Corresponding frequency range	Subcarrier Spacing
FR1	410MHz – 7125MHz	15, 30, 60kHz
FR2	24250MHz – 52600MHz	60, 120, 240kHz

[136] FIG. 6 illustrates a data flow example in the 3GPP NR system.

[137] In FIG. 6, "RB" denotes a radio bearer, and "H" denotes a header. Radio bearers are categorized into two groups: data radio bearers (DRB) for user plane data and signaling radio bearers (SRB) for control plane data. The MAC PDU is transmitted/received using radio resources through the PHY layer to/from an external device. The MAC PDU arrives to the PHY layer in the form of a transport block.

[138] In the PHY layer, the uplink transport channels UL-SCH and RACH are mapped to physical uplink shared channel (PUSCH) and physical random access channel (PRACH), respectively, and the downlink transport channels DL-SCH, BCH and PCH are mapped to physical downlink shared channel (PDSCH), physical broad cast channel (PBCH) and PDSCH, respectively. In the PHY layer, uplink control information (UCI) is mapped to PUCCH, and downlink control information (DCI) is mapped to PDCCH. A MAC PDU related to UL-SCH is transmitted by a UE via a PUSCH based on an UL grant, and a MAC PDU related to DL-SCH is transmitted by a BS via a PDSCH based on a DL assignment.

[139] For UCI transmission/reception, the following PUCCH formats may be used.

[140]

[Table 4]

PUCCH format	Length in OFDM symbols	Number of UCI bits
0	1 – 2	≤ 2
1	4 – 14	≤ 2
2	1 – 2	> 2
3	4 – 14	> 2
4	4 – 14	> 2

[141] PUCCH format 0 is a short PUCCH of 1 or 2 symbols with small UCI payloads of up to two bits. PUCCH format 1 is a long PUCCH of 4 to 14 symbols with small UCI payloads of up to 2 bits. PUCCH format 2 is a short PUCCH of 1 or 2 symbols with large UCI payloads of more than two bits with no UE multiplexing capability in the same PRBs. PUCCH format 3 is a long PUCCH of 4 to 14 symbols with large UCI payloads with no UE multiplexing capability in the same PRBs. PUCCH format 4 is a long PUCCH of 4 to 14 symbols with moderate UCI payloads with multiplexing capacity of up to 4 UEs in the same PRBs. For each PUCCH format, resource location is configured by RRC signalling. For example, IE *PUCCH-Config* is used to configure UE specific PUCCH parameters (per BWP).

[142] An operation to be first performed by the UE to receive services in association with a wireless communication system includes acquiring time and frequency synchronization of the corresponding system, receiving basic system information (SI), and synchronizing uplink timing to an uplink. This procedure will be referred to as an initial access procedure. The initial access procedure generally includes a synchronization procedure and a random access procedure. In a 3GPP based communication system, when a UE is powered on or desires to access a new cell, the UE perform an initial cell search procedure including acquiring time and frequency synchronization with the cell and detecting a physical layer cell identity $N^{\text{cell}}_{\text{ID}}$ of the cell. To this end, the UE may receive synchronization signals, for example, a primary synchronization signal (PSS) and a secondary synchronization signal (SSS), from a BS to thus establish synchronization with the eNB and acquire information such as a cell identity (ID).

[143] For example, the UE acquires OFDM symbol timing and slot timing based on PSS and SSS and also acquires cell ID, and acquires important information in the corresponding system by descrambling and decoding a PBCH using a cell ID. After completing the synchronization procedure, the UE performs a random access procedure. In other words, after the initial cell search procedure, the UE may perform a random access procedure to complete access to the BS. To this end, the UE may transmit a preamble through a physical random access channel (PRACH) and receive a response message to the preamble through a PDCCH and a PDSCH. After performing the aforementioned procedures, the UE may perform PDCCH/PDSCH reception and PUSCH/PUCCH transmission as a normal UL/DL transmission procedure. The

random access procedure is also referred to as a random access channel (RACH) procedure. The random access procedure is used for various purposes including initial access, adjustment of UL synchronization, resource assignment, and handover.

[144] The random access procedure is classified into a contention-based procedure and a dedicated (that is, contention-free based) procedure. The contention-based random access (CBRA) procedure is generally used for initial access, and the contention-free random access (CFRA) procedure is restrictively used for handover. In the CBRA procedure, the UE randomly selects RACH preamble sequence. Therefore, a plurality of UEs may transmit the same random access preamble sequence, whereby a contention resolution procedure is required. On the other hand, in the CFRA procedure, the UE uses a random access preamble sequence uniquely allocated to a corresponding UE. Therefore, the UE may perform the random access procedure without contention with another UE.

[145] FIG. 7 and FIG. 8 illustrate examples of random access procedures in the 3GPP based system. In particular, FIG. 7 illustrates an example of a flow diagram of the CBRA procedure in the 3GPP based system, and FIG. 8 illustrates an example of a flow diagram of the CFRA procedure in the 3GPP based system.

[146] Referring to FIG. 7, the CBRA procedure includes four steps as follows. Hereinafter, messages transmitted in the steps 1 to 4 may be referred to as 1 to 4 (Msg1 to Msg4):

[147] - Step 1: random access preamble (via PRACH) (UE to BS);

[148] - Step 2: random access response (RAR) (via PDCCH and PDSCH) (BS to UE);

[149] - Step 3: layer 2 / layer 3 message (via PUSCH) (UE to BS);

[150] - Step 4: contention resolution message (BS to UE).

[151] Referring to FIG. 8, the CFRA procedure includes three steps as follows. Hereinafter, messages transmitted in steps 0 to 2 may be referred to as messages 0 to 2 (Msg0 to Msg2). As a part of the random access procedure, uplink transmission (that is, step 3) corresponding to RAR may be performed. The dedicated random access procedure may be triggered using a PDCCH (hereinafter, PDCCH order) for commanding random access preamble transmission:

[152] - Step 0: RACH preamble allocation (BS to UE) through dedicated signaling;

[153] - Step 1: RACH preamble (via PRACH) (UE to BS); and

[154] - Step 2: random access response (RAR) (via PDCCH and PDSCH) (BS to UE).

[155] After transmitting the RACH preamble, the UE attempts to receive a random access response (RAR) within a preset time window. Specifically, the UE attempts to detect a PDCCH with a random access radio network temporary identifier (RA-RNTI) (hereinafter, RA-RNTI PDCCH) (e.g., CRC is masked with RA-RNTI on the PDCCH) in the time window. In detecting the RA-RNTI PDCCH, the UE checks the PDSCH corresponding to the RA-RNTI PDCCH for presence of an RAR directed thereto. The

RA-RNTI associated with the PRACH occasion in which the Random Access Preamble is transmitted, is computed as:

[156] $RA-RNTI = 1 + s_id + 14 \times t_id + 14 * 80 * f_id + 14 * 80 * 8 * ul_carrier_id$

[157] where s_id is the index of the first OFDM symbol of the PRACH occasion ($0 \leq s_id < 14$), t_id is the index of the first slot of the PRACH occasion in a system frame ($0 \leq t_id < 80$), f_id is the index of the PRACH occasion in the frequency domain ($0 \leq f_id < 8$), and $ul_carrier_id$ is the UL carrier used for Random Access Preamble transmission (0 for normal uplink (NUL) carrier, and 1 for supplementary uplink (SUL) carrier).

[158] The RAR includes timing advance (TA) information indicating timing offset information for UL synchronization, UL resource allocation information (UL grant information), and a temporary UE identifier (e.g., temporary cell-RNTI (TC-RNTI)). The UE may perform UL transmission (of, e.g., Msg3) according to the resource allocation information and the TA value in the RAR. HARQ is applied to UL transmission corresponding to the RAR. Accordingly, after transmitting Msg3, the UE may receive acknowledgement information corresponding to Msg3.

[159] For example, once the random access preamble is transmitted, the MAC entity of the UE:

[160] 1> else if a downlink assignment has been received on the PDCCH for the RA-RNTI and the received TB is successfully decoded:

[161] 2> if the Random Access Response contains a MAC subPDU with Backoff Indicator:

[162] 3> sets the *PREAMBLE_BACKOFF* to a value of the BI field of the MAC subPDU based on predefined backoff parameter values, multiplied with *SCALING_FACTOR_BI*, where *SCALING_FACTOR_BI* is a UE variable for the random access procedure

[163] 2> else:

[164] 3> sets the *PREAMBLE_BACKOFF* to 0 ms.

[165] 2> if the Random Access Response contains a MAC subPDU with Random Access Preamble identifier corresponding to the transmitted *PREAMBLE_INDEX* (e.g. RAPID of the transmitted random access preamble):

[166] 3> considers this Random Access Response reception successful.

[167] 2> if the Random Access Response reception is considered successful:

[168] 3> if the Random Access Response includes a MAC subPDU with RAPID only:

[169] 4> considers this Random Access procedure successfully completed;

[170] 4> indicates the reception of an acknowledgement for system information (SI) request to upper layers.

[171] 3> else:

[172] 4> applies the following actions for the Serving Cell where the Random Access

Preamble was transmitted:

- [173] 5> processes the received Timing Advance Command;
- [174] 5> indicates the *preambleReceivedTargetPower* and the amount of power ramping applied to the latest Random Access Preamble transmission to lower layers (i.e. ($PREAMBLE_POWER_RAMPING_COUNTER - 1$) * $PREAMBLE_POWER_RAMPING_STEP$);
- [175] 5> if the Serving Cell for the Random Access procedure is sounding reference signal only SCell (SRS-only SCell):
- [176] 6> ignores the received UL grant.
- [177] 5> else:
- [178] 6> processes the received UL grant value and indicates it to the lower layers.
- [179] 4> if the Random Access Preamble was not selected by the MAC entity among the contention-based Random Access Preamble(s):
- [180] 5> considers the Random Access procedure successfully completed.
- [181] 4> else:
- [182] 5> sets the *TEMPORARY_C-RNTI* to the value received in the Random Access Response;
- [183] 5> if this is the first successfully received Random Access Response within this Random Access procedure:
- [184] 6> if the transmission is not being made for the CCCH logical channel:
- [185] 7> indicates to the Multiplexing and assembly entity to include a C-RNTI MAC CE in the subsequent uplink transmission.
- [186] 6> obtains the MAC PDU to transmit from the Multiplexing and assembly entity and stores it in the Msg3 buffer.
- [187] Once Msg3 is transmitted, the MAC entity of the UE may:
- [188] 1> start the *ra-ContentionResolutionTimer* and restart the *ra-ContentionResolutionTimer* at each HARQ retransmission in the first symbol after the end of the Msg3 transmission;
- [189] 1> monitor the PDCCH while the *ra-ContentionResolutionTimer* is running regardless of the possible occurrence of a measurement gap;
- [190] 1> if notification of a reception of a PDCCH transmission of the SpCell is received from lower layers:
- [191] 2> if the C-RNTI MAC CE was included in Msg3:
- [192] 3> if the Random Access procedure was initiated for beam failure recovery and the PDCCH transmission is addressed to the C-RNTI; or
- [193] 3> if the Random Access procedure was initiated by a PDCCH order and the PDCCH transmission is addressed to the C-RNTI; or
- [194] 3> if the Random Access procedure was initiated by the MAC sublayer itself or by

the RRC sublayer and the PDCCH transmission is addressed to the C-RNTI and contains a UL grant for a new transmission:

- [195] 4> consider this Contention Resolution successful;
- [196] 4> stop *ra-ContentionResolutionTimer*;
- [197] 4> discard the *TEMPORARY_C-RNTI*;
- [198] 4> consider this Random Access procedure successfully completed.
- [199] 2> else if the CCCH SDU was included in Msg3 and the PDCCH transmission is addressed to its *TEMPORARY_C-RNTI*:
- [200] 3> if the MAC PDU is successfully decoded:
- [201] 4> stop *ra-ContentionResolutionTimer*;
- [202] 4> if the MAC PDU contains a UE Contention Resolution Identity MAC CE; and
- [203] 4> if the UE Contention Resolution Identity in the MAC CE matches the CCCH SDU transmitted in Msg3:
- [204] 5> consider this Contention Resolution successful and finish the disassembly and demultiplexing of the MAC PDU;
- [205] 5> if this Random Access procedure was initiated for SI request:
- [206] 6> indicate the reception of an acknowledgement for SI request to upper layers.
- [207] 5> else:
- [208] 6> set the C-RNTI to the value of the *TEMPORARY_C-RNTI*;
- [209] 5> discard the *TEMPORARY_C-RNTI*;
- [210] 5> consider this Random Access procedure successfully completed.
- [211] 4> else:
- [212] 5> discard the *TEMPORARY_C-RNTI*;
- [213] 5> consider this Contention Resolution not successful and discard the successfully decoded MAC PDU.
- [214] FIG. 9 illustrates examples of MAC PDU. In particular, FIG. 9(a) illustrates an example of UL MAC PDU consisting of MAC RARs, and FIG. 9(b) illustrates an example of a DL MAC PDU.
- [215] Referring to FIG. 9(a), a MAC PDU for RAR may consist of one or more MAC subPDUs and optionally padding.
- [216] FIG. 10 illustrates examples of MAC subheader related to RAR. For example, in some scenarios, each MAC subPDU may consist one of the following:
- [217] - a MAC subheader with Backoff Indicator only;
- [218] - a MAC subheader with RAPID only (i.e. acknowledgment for SI request);
- [219] - a MAC subheader with RAPID and MAC RAR.
- [220] In some scenarios, a MAC subheader with Backoff Indicator may consist of five header fields E/T/R/R/BI as shown in FIG. 10(a). A MAC subPDU with Backoff Indicator only is placed at the beginning of the MAC PDU, if included. 'MAC

subPDU(s) with RAPID only' and 'MAC subPDU(s) with RAPID and MAC RAR' can be placed anywhere between MAC subPDU with Backoff Indicator only (if any) and padding (if any). A MAC subheader with RAPID may consist of three header fields E/T/RAPID as shown in FIG. 10(b). Padding is placed at the end of the MAC PDU if present. Presence and length of padding is implicit based on transport block (TB) size, size of MAC subPDU(s).

- [221] Referring to FIG. 9(b), a DL MAC PDU for DL-SCH may consist of one or more MAC subPDUs. Each MAC subPDU consists of one of the following:
- [222] - A MAC subheader only (including padding);
 - [223] - A MAC subheader and a MAC SDU;
 - [224] - A MAC subheader and a MAC CE;
 - [225] - A MAC subheader and padding.
- [226] The MAC SDUs may be of variable sizes. Each MAC subheader corresponds to either a MAC SDU, a MAC CE, or padding.
- [227] FIG. 11 illustrates examples of MAC subheader used in a MAC PDU for DL-SCH and UL-SCH. In particular, FIG. 11(a) illustrates an example of R/F/LCID/L MAC subheader with 8-bit L field, FIG. 11(b) illustrates an example of R/F/LCID/L MAC subheader with 16-bit L field, and FIG. 11(c) illustrates an example of R/LCID MAC subheader.
- [228] A MAC subheader except for fixed sized MAC CE, padding, and a MAC SDU containing UL CCCH consists of the four header fields R/F/LCID/L. A MAC subheader for fixed sized MAC CE, padding, and a MAC SDU containing UL CCCH consists of the two header fields R/LCID. Referring to FIG. 9(b), MAC CEs may be placed together. For a DL MAC PDU, DL MAC subPDU(s) with MAC CE(s) may be placed before any MAC subPDU with MAC SDU and MAC subPDU with padding as shown in FIG. 9(b). For a UL MAC PDU (not shown), UL MAC subPDU(s) with MAC CE(s) may be placed after all the MAC subPDU(s) with MAC SDU and before the MAC subPDU with padding. The size of padding can be zero.
- [229] A Msg4 of the 4-step RACH shown in FIG. 7 may include a UE Contention Resolution Identity MAC CE. The UE Contention Resolution Identity MAC CE may be identified by MAC PDU subheader with LCID. In some scenarios, the UE Contention Resolution Identity MAC CE may consist of a UE Contention Resolution Identity field. The UE Contention Resolution Identity field may contain the UL CCCH SDU transmitted in the Msg3.
- [230] The MAC subheader for DL-SCH and UL-SCH may consist of the logical channel ID (LCID) field, the length (L) field, the format (F) field, and the reserved (R) bit set to "0". The LCID field identifies the logical channel instance of the corresponding MAC SDU or the type of the corresponding MAC CE or padding. There is one LCID field

per MAC subheader. The following table shows examples of values of LCID for DL-SCH.

[231] [Table 5]

Index	LCID values
0	CCCH
1-32	Identity of the logical channel
33-46	Reserved
47	Recommended bit rate
48	SP ZP CSI-RS Resource Set Activation/Deactivation
49	PUCCH spatial relation Activation/Deactivation
50	SP SRS Activation/Deactivation
51	SP CSI reporting on PUCCH Activation/Deactivation
52	TCI State Indication for UE-specific PDCCH
53	TCI States Activation/Deactivation for UE-specific PDSCH
54	Aperiodic CSI Trigger State Subselection
55	SP CSI-RS / CSI-IM Resource Set Activation/Deactivation
56	Duplication Activation/Deactivation
57	SCell Activation/Deactivation (four octet)
58	SCell Activation/Deactivation (one octet)
59	Long DRX Command
60	DRX Command
61	Timing Advance Command
62	UE Contention Resolution Identity
63	Padding

[232] The random access procedure illustrated in FIG. 7 and FIG. 8 involves at least four or three steps of signal transmissions/receptions between the BS and the UE before the random access procedure is completed successfully. It results in communication delay between the BS and the UE. Recently, 2-step random access procedure (hereinafter, 2-step RACH) is under discussion in order to reduce the communication delay. For the 2-step RACH, the messages in time order are named as Msg A and MsgB.

[233] In some implementations of the present disclosure, the 2-step RACH may be designed based on the following assumption(s):

[234] - Only CBRA procedure is specified for the 2-step RACH;

[235] - The 2-step RACH shall be able to operate regardless of whether the UE has valid timing advance (TA) or not;

[236] - The 2-step RACH is applicable to any cell size supported in the wireless communication system;

[237] - The 2-step RACH is applied for RRC_INACTIVE, RRC_CONNECTED and RRC_IDLE;

[238] - Channel structure of MsgA is i) preamble and ii) PUSCH carrying payload.

[239] - The mapping between i) the PRACH preamble and ii) the time-frequency resource of PUSCH in MsgA (and DMRS);

- [240] - All triggers for the 4-step RACH (e.g. see the document 3GPP TS 38.321 V15.3.0, at section 5.4.4 'Scheduling Request', section 5.15 'Bandwidth Part (BWP) operation' and section 5.17 'Beam Failure Detection and Recovery procedure') may be applied for the 2-step RACH); and/or
- [241] - The fallback procedure from the 2-step RACH to the 4-step RACH may be designed.
- [242] Based on the above assumption(s), in some implementations of the present, the following 2-step RACH procedures may be considered.
- [243] FIG. 12 illustrates examples of flow diagrams of the 2-step RACH procedure in some implementations of the present disclosure. In particular, FIG. 12 illustrates examples of the 2-step RACH procedure successfully completed. In more particular, FIG. 12(a) illustrates an example of a successfully completed 2-step RACH involving a fallback to the 4-step RACH, and FIG. 12(b) illustrates an example of a successfully completed 2-step RACH without a fallback to the 4-step RACH.
- [244] The UE transmits simultaneously or sequentially a preamble and a PUSCH carrying payload. The UE calculates RA-RNTI based on the transmitted preamble. The UE also calculates RNTI for MsgB based on the PUSCH resource and/or PRACH resource of transmitted MsgA. The RNTI for MsgB (MsgB-RNTI) may be the same as or different from the RA-RNTI for msg2/RAR to indicate the fallback to the 4-step RACH.
- [245] The UE monitors PDCCH addressed by RA-RNTI during a RAR window (e.g. UE monitors PDCCH addressed by RA-RNTI while a timer related to the RAR window is running).
- [246] The UE may monitor PDCCH addressed by MsgB-RNTI (e.g., while contention resolution (CR) timer is running).
- [247] Referring to FIG. 12(a), if the UE receives a RAR message with the transmitted preamble ID during a RAR window (e.g. if the UE receives a RAR message with the transmitted preamble ID while a timer related to the RAR window is running), the UE may fall back to the 4-step RACH procedure. The RAR message contains at least one of timing advance (TA) value, TC-RNTI and UL grant.
- [248] FIG. 13 illustrates an example of a RAR MAC PDU for a fallback from a 2-step RACH to a 4-step RACH in some implementations of the present disclosure. Referring to FIG. 13, the RAR MAC PDU for the fallback to the 4-step RACH may consist of a random access preamble ID (RAPID) subheader and a RAR payload. The format of the RAR MAC PDU may be used in the 4-step RACH.
- [249] The MAC subheader for RAR may consist of the extension field (E) field, the type (T) field, reserved bit (R), the backoff indicator (BI) field; and/or the random access preamble identifier (RAPID) field. The E field in the MAC subheader is a flag indicating if the MAC subPDU including this MAC subheader is the last MAC subPDU

or not in the RAR MAC PDU. Alternatively, the E field is a flag indicating if this MAC subheader is the last MAC subheader or not in the RAR MAC PDU. The T field in the MAC subheader is a flag indicating whether the MAC subheader contains an RAPID or a BI. For example, the T field is set to "0" to indicate the presence of a BI field in the MAC subheader, and the T field is set to "1" to indicate the presence of a RAPID field in the MAC subheader. The reserved bit (R) is set to "0". The BI field identified the overload condition in the cell. The size of the BI field is 4 bits. The RAPID field identifies the transmitted RAP. If the RAPID in the MAC subheader of a MAC subPDU corresponds to one of the RAPs configured for SI request, MAC RAR is not included in the MAC subPDU.

- [250] Referring to FIG. 13, the MAC RAR may consist of a reserved bit (R), the timing advance command (TA) field, the UL grant field, and the TC-RNTI field. The reserved bit (R) is set to 0. The TA field indicates the index value T_A used to control the amount of timing adjustment that the MAC entity has to apply. The size of the TA field may be 12 bits. The UL grant field indicates the resources to be used on the uplink. The size of the UL grant field may be 27 bits. The TC-RNTI field indicates the temporary identify that is used by the MAC entity during random access. The size of the TC-RNTI field may be 16 bits.
- [251] Referring to FIG. 12(a), after receiving the RAR MAC PDU (e.g. RAR MAC PDU shown in FIG. 13) in response to the transmitted preamble, the UE may follow the conventional 4-step RACH procedure.
- [252] Referring to FIG. 12(b), however, if the UE receives MsgB including its UE ID (e.g., while the CR timer is running), the UE may consider that the random access (RA) procedure has been successfully completed. The MsgB may contain a UE ID which was transmitted in MsgA. In some implementations of the present disclosure, the MsgB may contain a timing advance command, a C-RNTI, and a RRC response message if the UE transmitted a RRC message in MsgA. The MsgB may be addressed to C-RNTI which was transmitted in MsgA, and contain a timing advance command and an MAC SDU.
- [253] If the CR timer has expired, the UE may consider this contention resolution not successful.
- [254] In some scenarios of the present disclosure, in the 2-step RACH, if the preamble is unsuccessfully transmitted to the network (e.g. BS), a UE cannot detect the failure of the RACH procedure until the CR timer expires.
- [255] FIG. 14 illustrates examples of random access (RA) retry which may occur during the random access procedures. In particular, FIG. 14(a) illustrates an example of the RA retry in the 4-step RACH procedure, and FIG. 14(b) illustrates an example of the RA retry in the 2-step RACH procedure.

- [256] As shown in FIG. 14, when the network did not receive any signal/preamble of a RACH procedure for a UE, it cannot do any operations for the UE. Generally, the UE may decide the failure of the RACH procedure after waiting for a while by using a timer. In the meanwhile, the UE initiated with a 2-step RACH procedure expects to receive MsgB even if the RAR window has expired, since the network would transmit the MsgB for the UE when successfully receiving both a preamble of MsgA and a PUSCH of the MsgA. In some scenarios which use a CR timer, if there is an error in transmission of an MsgB, it would be reasonable to retry a RACH procedure when the CR timer has expired. But, if there was an error during transmission of the preamble, but there was no error in transmission of the MsgB, it happens that the UE unnecessary waits for the expiry of the CR timer. In some scenarios, a value for the CR timer may be up to 64 ms which is much longer than the maximum value 10 ms for the RAR window timer. This could lead to the delay for the 2-step RACH retry.
- [257] In some scenarios, the RA-RNTI is associated with the PRACH occasion in which the random access (RA) preamble is transmitted, and the UE calculates the RA-RNTI based on resource information of PRACH occasion. The PUSCH occasion for the 2-step RACH is newly defined as the time-frequency resource for payload transmission of MsgA. In a similar way to RA-RNTI, the RNTI for MsgB may be associated with the PRACH and/or PUSCH occasion of MsgA. If the MsgA contains C-RNTI, the MsgB can be addressed to the C-RNTI which was transmitted in MsgA. In this case, the UE would receive a MAC PDU including only one MsgB for its C-RNTI. However, if the MsgA contains a CCCH MAC SDU, the UE may receive a MAC PDU including one or more MsgBs for different UEs. That is, if the RNTI for MsgB is associated with the PRACH occasion, MsgBs for all RAPIDs transmitted on a PRACH occasion may be multiplexed into one MAC PDU like the RAR transmission in the 4-step RACH. Even if the RNTI for MsgB is associated with the PUSCH occasion in which the payload of MsgA is transmitted, MsgBs for RAPIDs associated with the PUSCH occasion may be also multiplexed into one MAC PDU because the mapping between RAPID and PUSCH occasion may be many to one. Otherwise, there may be many cases where one or more MsgBs are multiplexed into one MAC PDU addressed to a RNTI.
- [258] The MsgB, which the network (e.g. BS) transmits for contention resolution of a UE after successfully receiving the preamble and payload of MsgA, may contain the following contents:
- [259] - UE Contention Resolution Identify;
 - [260] - C-RNTI;
 - [261] - Timing Advance Command (TAC); and/or
 - [262] - MAC SDU.

- [263] If one or more MsgBs are multiplexed into a MAC PDU, the UE has to decode the MAC PDU until detecting its UE Contention Resolution Identity (UE CRID). If each MsgB has a fixed size, the UE may simply check each UE CRID of MsgB. However, since a MAC SDU in MsgB may have a variable size per UE, the UE receiving multiplexed MsgBs may have to decode all MAC SDUs in the MAC PDU in order to detect its MsgB. In particular, in some scenarios, a DL MAC PDU may consist of one or more MAC CEs and/or one or more MAC SDUs as shown in FIG. 9(b).
- [264] FIG. 15 illustrates an example of a MAC PDU including multiple MsgBs.
- [265] If a MAC PDU generated as shown in FIG. 15 does not include MsgB for a UE, the UE may not recognize that there is not its MsgB until wholly decoding the MAC PDU. The more MsgBs are multiplexed into one MAC PDU, the higher processing delay is required for a UE.
- [266] In some implementations of the present disclosure, a new MAC CE, e.g., long UE CRID MAC CE is used, where the new MAC CE consists of UE CRIDs for MsgBs multiplexed into a MAC PDU. In some implementations of the present disclosure, this long UE CRID MAC CE may be located in the first portion of the MAC PDU for one or more MsgBs.
- [267] FIG. 16 illustrates an example of a long UE CRID MAC CE according to some implementations of the present disclosure, and FIG. 17 illustrates an example of a MAC PDU including the long UE CRID MAC CE.
- [268] Referring to FIG. 16, a UE may receive a MAC PDU including the long UE CRID MAC CE addressed to an RNTI for MsgB as illustrated in FIG. 17. First, the UE decodes this MAC CE to check whether this MAC PDU contains its MsgB or not. The MAC CE may be transmitted with subheader with a length field. In some scenarios, the MAC subheader with 8-bit or 16-bit Length field as shown in FIG. 11(a) or FIG. 11(b) may be used as the MAC subheader for the long UE CRID MAC CE. The new LCID for long UE CRID MAC CE may be defined. For example, the following table shows examples of values of LCID for DL-SCH, which includes the new LCID for the long UE CRID MAC CE.
- [269]

[Table 6]

Index	LCID values
0	CCCH
1-32	Identity of the logical channel
33-45	Reserved
46	Long UE Contention Resolution Identity
47	Recommended bit rate
48	SP ZP CSI-RS Resource Set Activation/Deactivation
49	PUCCH spatial relation Activation/Deactivation
50	SP SRS Activation/Deactivation
51	SP CSI reporting on PUCCH Activation/Deactivation
52	TCI State Indication for UE-specific PDCCH
53	TCI States Activation/Deactivation for UE-specific PDSCH
54	Aperiodic CSI Trigger State Subselection
55	SP CSI-RS / CSI-IM Resource Set Activation/Deactivation
56	Duplication Activation/Deactivation
57	SCell Activation/Deactivation (four octet)
58	SCell Activation/Deactivation (one octet)
59	Long DRX Command
60	DRX Command
61	Timing Advance Command
62	UE Contention Resolution Identity
63	Padding

[270] FIG. 18 illustrates an example of MsgB reception at a UE side according to some implementations of the present disclosure.

[271] Referring to FIG. 18, a UE may receive a MAC PDU for MsgB(s) of a random access procedure (S1801). Hereinafter, a MAC PDU for MsgB(s) is referred to as an MsgB MAC PDU. Here, the MsgB MAC PDU may be made for CCCH logical channel. In some implementations of the present disclosure, the MsgB may consist of or include at least a long UE contention resolution identity MAC CE, and one or more DL-SCH payloads (e.g. TAC, C-RNTI, and/or DL CCCH SDU).

[272] The UE may monitor MsgB MAC PDU(s) while a timer for MsgB is running. In the present disclosure, monitoring something implies decoding or attempting to decode the MAC PDU. The duration for the timer for MsgB (e.g. a timer value for the MsgB) may be configured by the network (e.g. BS) to the UE through RRC signaling.

[273] In some implementations of the present disclosure, if the UE receives a MsgB MAC PDU containing a long UE CRID MAC CE that includes multiple UE CRIDs (e.g., during the timer for MsgB), and if one of the UE CRIDs in the MAC CE matches the CCCH SDU transmitted in MsgA (S1803, Yes), the UE decodes the remaining/

following part of the MAC PDU (S1805), thereby acquiring a MsgB for the UE including at least one of Timing Advance Command, C-RNTI and CCCH MAC SDU (S1807), and considers this contention resolution successful. If the MAC CE does not contain a UE CRID matching the CCCH SDU transmitted in MsgA (S1803, No), the UE does not decode the remaining part of the MAC PDU (S1809) and continuously monitors MsgB MAC PDU(s) while a timer for MsgB is running.

[274] If the maximum number (hereinafter, maximum value) of random access (RA) preamble transmissions performed before the UE declares a failure is configured by the network and if the number of preamble transmissions performed by the UE for the RA procedure does not exceed the maximum value, the UE may retry the RA procedure. If the number of preamble transmissions performed by the UE for the RA procedure has reached the maximum value, then the UE may consider the RA procedure unsuccessfully completed and terminate the RA procedure.

[275] For example, in some implementations of the present disclosure, if the UE receives a MsgB MAC PDU with a long UE CRID MAC CE:

[276] - if one of UE CRIDs in the long UE CRID MAC CE matches the CCCH SDU transmitted in MsgA:

[277] the UE considers this Contention Resolution successful and decodes the remaining part of the MAC PDU;

[278] the MAC PDU is successfully decoded, the UE:

[279] stops the timer for MsgB; and

[280] sets the C-RNTI to the value of the C-RNTI of the MsgB; and

[281] processes the received Timing Advance Command for the serving cell where the RAP was transmitted.

[282] - else:

[283] the UE stops the decoding of the MAC PDU.

[284] FIG. 19 illustrates an example of decoding of an MsgB MAC PDU according to some implementations of the present disclosure.

[285] In some implementations of the present disclosure, the UE decodes the long UE CRID MAC CE of the MsgB MAC PDU first, and then if the UE detects its UE CRID in the MAC CE, it decodes the MsgB of the MAC PDU based on the order of detected UE CRID in the MAC CE. For example, if the UE detects its UE CRID through the 3rd UE CRID in the MAC CE, the UE recognizes that its MsgB is located in the 3rd MsgB in the remaining MAC PDU. For example, if the UE detects its UE CRID through the 3rd UE CRID of the MAC CE, the UE knows that its MsgB is located from the point of the (1st length + 2nd length + 1) bytes after this MAC CE to the (1st length + 2nd length + 3rd length) bytes. In order to acquire the exact location of the 3rd MsgB in the MAC PDU, the UE may decode the length field of MAC subheader for each MsgB.

- [286] FIG. 20 illustrates another example of long UE CRID MAC CE according to some implementations of the present disclosure, and FIG. 21 illustrates another example of a MAC PDU including the long UE CRID MAC CE.
- [287] In order for a UE to detect its MsgB of the MAC PDU fast, in some implementations of the present disclosure, the long UE CRID MAC CE may consist of sets of i) UE CRID and i) size field for MsgB multiplexed into a MAC PDU, as illustrated in FIG. 20. In some implementations of the present disclosure, this MAC CE may be located in the first of the MAC PDU for MsgB.
- [288] For example, referring to FIG. 20, a UE may receive a MAC PDU including the long UE CRID MAC CE addressed to RNTI for MsgB as illustrated in FIG. 21. The UE decodes this MAC CE first, to check whether this MAC PDU contains its MsgB or not. The MAC CE may be transmitted with a subheader with a length field. In some scenarios, the MAC subheader with 8-bit or 16-bit Length field as shown in FIG. 11(a) or FIG. 11(b) may be used as the MAC subheader for the long UE CRID MAC CE. The new LCID for long UE CRID MAC CE may be defined. For example, the new LCID for long UE CRID MAC CE may be defined to be included in a table for values of LCID for DL-SCH, as shown in Table 6.
- [289] FIG. 22 illustrates an example of a flow diagram for a random access procedure according to some implementations of the present disclosure.
- [290] A UE may transmit a MsgA of a 2-step RACH procedure (S2200), and receive a MAC PDU to detect MsgB in response to the MsgA. For example, the UE may transmit a RAP on a PRACH and a CCCH SDU on a PUSCH, as the MsgA. Then the UE may receive a MAC PDU based on transmitting the MsgA. The MAC PDU includes a first, and a second part after the first part, where the first part includes multiple UE CRIDs. The second part may include respective TACs associated with the multiple UE CRIDs. The UE may determine whether the multiple UE CRIDs include a UE CRID matching the CCCH SDU that the UE transmitted in the MsgA. The UE may process a TAC corresponding to the UE CRID if the multiple UE CRIDs include the UE CRID matching the CCCH SDU. The MAC PDU may include a UE CRID MAC CE, and the multiple UE CRID may be included in the UE CRID MAC CE. The MAC PDU may further include a MAC subheader for the UE CRID MAC CE. The MAC subheader may include a LCID field set to a value representing the UE CRID MAC CE that includes the multiple UE CRIDs.
- [291] In some implementations of the present disclosure, the UL data payload transmitted in MsgA may be transmitted/received on a physical channel (e.g. PUSCH) based on resource allocation (e.g. UL grant). In order to transmit the UL data payload, a UE shall have uplink resources available to the UE. In order for a BS to receive the UL payload of MsgA, the BS may have uplink resources available to the UE.

- [292] In some implementations of the present disclosure, UE CRID(s) and/or MsgB(s) may be transmitted/received on a physical channel (e.g. PDSCH) based on resource allocation (e.g. DL assignment). In order to receive a MAC PDU including UE CRID(s) and/or MsgB(s), a UE shall have downlink resources available to the UE. In order for a BS to transmit the MAC PDU, the BS may have downlink resources available to the UE.
- [293] In the present disclosure, uplink resource allocation is also referred to as uplink grant, and downlink resource allocation is also referred to as downlink assignment. The resource allocation includes time domain resource allocation and frequency domain resource allocation.
- [294] In order to transmit data unit(s) of the present disclosure on UL-SCH, a UE shall have uplink resources available to the UE. In order to receive data unit(s) of the present disclosure on DL-SCH, a UE shall have downlink resources available to the UE. The resource allocation includes time domain resource allocation and frequency domain resource allocation. In the present disclosure, uplink resource allocation is also referred to as uplink grant, and downlink resource allocation is also referred to as downlink assignment. An uplink grant is either received by the UE dynamically on PDCCH, in a Random Access Response, or configured to the UE semi-persistently by RRC. Downlink assignment is either received by the UE dynamically on the PDCCH, or configured to the UE semi-persistently by RRC signaling from the BS.
- [295] In UL, the BS can dynamically allocate resources to UEs via the Cell Radio Network Temporary Identifier (C-RNTI) on PDCCH(s). A UE always monitors the PDCCH(s) in order to find possible grants for uplink transmission when its downlink reception is enabled (activity governed by discontinuous reception (DRX) when configured). In addition, with Configured Grants, the BS can allocate uplink resources for the initial HARQ transmissions to UEs. Two types of configured uplink grants are defined: Type 1 and Type 2. With Type 1, RRC directly provides the configured uplink grant (including the periodicity). With Type 2, RRC defines the periodicity of the configured uplink grant while PDCCH addressed to Configured Scheduling RNTI (CS-RNTI) can either signal and activate the configured uplink grant, or deactivate it; i.e. a PDCCH addressed to CS-RNTI indicates that the uplink grant can be implicitly reused according to the periodicity defined by RRC, until deactivated.
- [296] In DL, the BS can dynamically allocate resources to UEs via the C-RNTI on PDCCH(s). A UE always monitors the PDCCH(s) in order to find possible assignments when its downlink reception is enabled (activity governed by DRX when configured). In addition, with Semi-Persistent Scheduling (SPS), the BS can allocate downlink resources for the initial HARQ transmissions to UEs: RRC defines the periodicity of the configured downlink assignments while PDCCH addressed to CS-

RNTI can either signal and activate the configured downlink assignment, or deactivate it. In other words, a PDCCH addressed to CS-RNTI indicates that the downlink assignment can be implicitly reused according to the periodicity defined by RRC, until deactivated.

[297] * Resource allocation by PDCCH (i.e. resource allocation by DCI)

[298] PDCCH can be used to schedule DL transmissions on PDSCH and UL transmissions on PUSCH, where the downlink control information (DCI) on PDCCH includes: downlink assignments containing at least modulation and coding format (e.g., modulation and coding scheme (MCS) index I_{MCS}), resource allocation, and hybrid-ARQ information related to DL-SCH; or uplink scheduling grants containing at least modulation and coding format, resource allocation, and hybrid-ARQ information related to UL-SCH. The size and usage of the DCI carried by one PDCCH are varied depending on DCI formats. For example, in the 3GPP NR system, DCI format 0_0 or DCI format 0_1 is used for scheduling of PUSCH in one cell, and DCI format 1_0 or DCI format 1_1 is used for scheduling of PDSCH in one cell.

[299] FIG. 23 illustrates an example of PDSCH time domain resource allocation by PDCCH, and an example of PUSCH time resource allocation by PDCCH.

[300] Downlink control information (DCI) carried by a PDCCH for scheduling PDSCH or PUSCH includes a value m for a row index $m+1$ to an allocation table for PDSCH or PUSCH. Either a predefined default PDSCH time domain allocation A, B or C is applied as the allocation table for PDSCH, or RRC configured *pdsch-TimeDomainAllocationList* is applied as the allocation table for PDSCH. Either a predefined default PUSCH time domain allocation A is applied as the allocation table for PUSCH, or the RRC configured *pusch-TimeDomainAllocationList* is applied as the allocation table for PUSCH. Which PDSCH time domain resource allocation configuration to apply and which PUSCH time domain resource allocation table to apply are determined according to a fixed/predefined rule (e.g. Table 5.1.2.1.1-1 in 3GPP TS 38.214 v15.3.0, Table 6.1.2.1.1-1 in 3GPP TS 38.214 v15.3.0).

[301] Each indexed row in PDSCH time domain allocation configurations defines the slot offset K_0 , the start and length indicator *SLIV*, or directly the start symbol S and the allocation length L , and the PDSCH mapping type to be assumed in the PDSCH reception. Each indexed row in PUSCH time domain allocation configurations defines the slot offset K_2 , the start and length indicator *SLIV*, or directly the start symbol S and the allocation length L , and the PUSCH mapping type to be assumed in the PUSCH reception. K_0 for PDSCH, or K_2 for PUSCH is the timing difference between a slot with a PDCCH and a slot with PDSCH or PUSCH corresponding to the PDCCH. *SLIV* is a joint indication of starting symbol S relative to the start of the slot with PDSCH or PUSCH, and the number L of consecutive symbols counting from the symbol S . For

PDSCH/PUSCH mapping type, there are two mapping types: one is Mapping Type A where demodulation reference signal (DMRS) is positioned in 3rd or 4th symbol of a slot depending on the RRC signaling, and other one is Mapping Type B where DMRS is positioned in the first allocated symbol.

[302] The scheduling DCI includes the *Frequency domain resource assignment* field which provides assignment information on resource blocks used for PDSCH or PUSCH. For example, the *Frequency domain resource assignment* field may provide a UE with information on a cell for PDSCH or PUSCH transmission, information on a bandwidth part for PDSCH or PUSCH transmission, information on resource blocks for PDSCH or PUSCH transmission.

[303] * Resource allocation by RRC

[304] As mentioned above, in uplink, there are two types of transmission without dynamic grant: configured grant Type 1 where an uplink grant is provided by RRC, and stored as configured grant; and configured grant Type 2 where an uplink grant is provided by PDCCH, and stored or cleared as configured uplink grant based on L1 signaling indicating configured uplink grant activation or deactivation. Type 1 and Type 2 are configured by RRC per serving cell and per BWP. Multiple configurations can be active simultaneously only on different serving cells. For Type 2, activation and deactivation are independent among the serving cells. For the same serving cell, the MAC entity is configured with either Type 1 or Type 2.

[305] A UE is provided with at least the following parameters via RRC signaling from a BS when the configured grant type 1 is configured:

[306] - *cs-RNTI* which is CS-RNTI for retransmission;

[307] - *periodicity* which provides periodicity of the configured grant Type 1;

[308] - *timeDomainOffset* which represents offset of a resource with respect to SFN=0 in time domain;

[309] - *timeDomainAllocation* value m which provides a row index $m+1$ pointing to an allocation table, indicating a combination of a start symbol S and length L and PUSCH mapping type;

[310] - *frequencyDomainAllocation* which provides frequency domain resource allocation; and

[311] - *mcsAndTBS* which provides I_{MCS} representing the modulation order, target code rate and transport block size. Upon configuration of a configured grant Type 1 for a serving cell by RRC, the UE stores the uplink grant provided by RRC as a configured uplink grant for the indicated serving cell, and initialise or re-initialise the configured uplink grant to start in the symbol according to *timeDomainOffset* and S (derived from $SLIV$), and to reoccur with *periodicity*. After an uplink grant is configured for a configured grant Type 1, the UE considers that the uplink grant recurs associated with each

symbol for which: $[(SFN * numberOfSlotsPerFrame * numberOfSymbolsPerSlot) + (\text{slot number in the frame} * numberOfSymbolsPerSlot) + \text{symbol number in the slot}] = (\text{timeDomainOffset} * numberOfSymbolsPerSlot + S + N * periodicity) \text{ modulo } (1024 * numberOfSlotsPerFrame * numberOfSymbolsPerSlot)$, for all $N \geq 0$.

[312] A UE is provided with at least the following parameters via RRC signaling from a BS when the configured grant Type 2 is configured:

[313] - *cs-RNTI* which is CS-RNTI for activation, deactivation, and retransmission; and

[314] - *periodicity* which provides periodicity of the configured grant Type 2. The actual

uplink grant is provided to the UE by the PDCCH (addressed to CS-RNTI). After an uplink grant is configured for a configured grant Type 2, the UE considers that the

uplink grant recurs associated with each symbol for which: $[(SFN * numberOfS-$

*lotsPerFrame * numberOfSymbolsPerSlot) + (\text{slot number in the frame} * numberOf-*

*SymbolsPerSlot) + symbol number in the slot] = [(SFN_{start time} * numberOfS-*

*lotsPerFrame * numberOfSymbolsPerSlot + slot_{start time} * numberOfSymbolsPerSlot +*

*symbol_{start time}) + N * periodicity] modulo (1024 * numberOfSlotsPerFrame * num-*

berOfSymbolsPerSlot), for all $N \geq 0$, where SFN_{start time}, slot_{start time}, and symbol_{start time}

are the SFN, slot, and symbol, respectively, of the first transmission opportunity of

PUSCH where the configured uplink grant was (re-)initialised. *numberOfS-*

lotsPerFrame and *numberOfSymbolsPerSlot* refer to the number of consecutive slots

per frame and the number of consecutive OFDM symbols per slot, respectively (see

Table 1 and Table 2).

[315] For configured uplink grants, the HARQ Process ID associated with the first symbol of a UL transmission is derived from the following equation:

[316] HARQ Process ID = $[\text{floor}(\text{CURRENT_symbol} / \text{periodicity})] \text{ modulo } nrofHARQ\text{-Processes}$

[317] where CURRENT_symbol = $(SFN * numberOfSlotsPerFrame * numberOfSymbolsPerSlot + \text{slot number in the frame} * numberOfSymbolsPerSlot + \text{symbol number in the slot})$, and *numberOfSlotsPerFrame* and *numberOfSymbolsPerSlot* refer to the number of consecutive slots per frame and the number of consecutive symbols per slot, respectively as specified in TS 38.211. CURRENT_symbol refers to the symbol index of the first transmission occasion of a repetition bundle that takes place. A HARQ process is configured for a configured uplink grant if the configured uplink grant is activated and the associated HARQ process ID is less than *nrofHARQ-Processes*.

[318] For downlink, a UE may be configured with semi-persistent scheduling (SPS) per serving cell and per BWP by RRC signaling from a BS. Multiple configurations can be active simultaneously only on different serving cells. Activation and deactivation of the DL SPS are independent among the serving cells. For DL SPS, a DL assignment is provided to the UE by PDCCH, and stored or cleared based on L1 signaling indicating

SPS activation or deactivation. A UE is provided with the following parameters via RRC signaling from a BS when SPS is configured:

- [319] - *cs-RNTI* which is CS-RNTI for activation, deactivation, and retransmission;
- [320] - *nrofHARQ-Processes*: which provides the number of configured HARQ processes for SPS;
- [321] - *periodicity* which provides periodicity of configured downlink assignment for SPS.

When SPS is released by upper layers, all the corresponding configurations shall be released.

- [322] After a downlink assignment is configured for SPS, the UE considers sequentially that the N^{th} downlink assignment occurs in the slot for which: $(\text{numberOfSlotsPerFrame} * \text{SFN} + \text{slot number in the frame}) = [(\text{numberOfSlotsPerFrame} * \text{SFN}_{\text{start time}} + \text{slot}_{\text{start time}}) + N * \text{periodicity} * \text{numberOfSlotsPerFrame} / 10] \text{ modulo } (1024 * \text{numberOfSlotsPerFrame})$, where $\text{SFN}_{\text{start time}}$ and $\text{slot}_{\text{start time}}$ are the SFN and slot, respectively, of the first transmission of PDSCH where the configured downlink assignment was (re-)initialised.

- [323] For configured downlink assignments, the HARQ Process ID associated with the slot where the DL transmission starts is derived from the following equation:

- [324] $\text{HARQ Process ID} = [\text{floor}(\text{CURRENT_slot} * 10 / (\text{numberOfSlotsPerFrame} * \text{periodicity}))] \text{ modulo } \text{nrofHARQ-Processes}$

- [325] where $\text{CURRENT_slot} = [(\text{SFN} * \text{numberOfSlotsPerFrame}) + \text{slot number in the frame}]$ and *numberOfSlotsPerFrame* refers to the number of consecutive slots per frame as specified in TS 38.211.

- [326] A UE validates, for scheduling activation or scheduling release, a DL SPS assignment PDCCH or configured UL grant type 2 PDCCH if the cyclic redundancy check (CRC) of a corresponding DCI format is scrambled with CS-RNTI provided by the RRC parameter *cs-RNTI* and the new data indicator field for the enabled transport block is set to 0. Validation of the DCI format is achieved if all fields for the DCI format are set according to Table 7 or Table 8. Table 7 shows special fields for DL SPS and UL grant Type 2 scheduling activation PDCCH validation, and Table 8 shows special fields for DL SPS and UL grant Type 2 scheduling release PDCCH validation.

- [327] [Table 7]

	DCI format 0_0/0_1	DCI format 1_0	DCI format 1_1
HARQ process number	set to all '0's	set to all '0's	set to all '0's
Redundancy version	set to '00'	set to '00'	For the enabled transport block: set to '00'

- [328]

[Table 8]

	DCI format 0_0	DCI format 1_0
HARQ process number	set to all '0's	set to all '0's
Redundancy version	set to '00'	set to '00'
Modulation and coding scheme	set to all '1's	set to all '1's
Resource block assignment	set to all '1's	set to all '1's

- [329] Actual DL assignment and actual UL grant, and the corresponding modulation and coding scheme are provided by the resource assignment fields (e.g. time domain resource assignment field which provides *Time domain resource assignment* value m , frequency domain resource assignment field which provides the frequency resource block allocation, modulation and coding scheme field) in the DCI format carried by the DL SPS and UL grant Type 2 scheduling activation PDCCH. If validation is achieved, the UE considers the information in the DCI format as valid activation or valid release of DL SPS or configured UL grant Type 2.
- [330] The time-frequency resource for PUSCH of the MsgA may be predefined to have a certain mapping relation with the PRACH occasion (e.g. time-frequency resource for transmission of the RAP) and/or the RAPID of the RAP in the MsgA. Alternatively, the time-frequency resource for PUSCH of the MsgA may be configured or allocated by the BS to have a certain mapping relation with the PRACH occasion (e.g. time-frequency resource for transmission of the RAP) and/or the RAPID of the RAP in the MsgA. The UE transmitting the MsgA monitors a PDCCH addressed to a MsgB-RNTI (or RA-RNTI) to receive a MAC PDU for MsgB.
- [331] The processor(s) 102 of the present disclosure may transmit (or control the transceiver(s) 106 to transmit) the UL data payload of the MsgA based on the UL grant available to the processor(s) 102. The processor(s) 202 may receive (or control its transceiver(s) 206 to receive) the UL data payload of the MsgA based on the UL grant available to the UE.
- [332] The processor(s) 102 of the present disclosure may receive (or control the transceiver(s) 106 to receive) MsgB in response to the MsgA. The processor(s) 202 may transmit (or control its transceiver(s) 206 to transmit) a MAC PDU for MsgB(s) based on DL assignment available to the UE.
- [333] The UL or DL data is subject to the physical layer processing at a transmitting side before transmission via radio interface, and the radio signals carrying the UL or DL data are subject to the physical layer processing at a receiving side. For example, a MAC PDU including the UL payload of the MsgA and/or an MsgB MAC PDU may be subject to the physical layer processing as follows.
- [334] FIG. 24 illustrates an example of physical layer processing for some implementations

of the present disclosure.

[335] FIG. 24(a) illustrates an example of physical layer processing at a transmitting side.

[336] The following tables show the mapping of the transport channels (TrCHs) and control information to its corresponding physical channels. In particular, Table 9 specifies the mapping of the uplink transport channels to their corresponding physical channels, Table 10 specifies the mapping of the uplink control channel information to its corresponding physical channel, Table 11 specifies the mapping of the downlink transport channels to their corresponding physical channels, and Table 12 specifies the mapping of the downlink control channel information to its corresponding physical channel.

[337] [Table 9]

TrCH	Physical Channel
UL-SCH	PUSCH
RACH	PRACH

[338] [Table 10]

Control information	Physical Channel
UCI	PUCCH, PUSCH

[339] [Table 11]

TrCH	Physical Channel
DL-SCH	PDSCH
BCH	PBCH
PCH	PDSCH

[340] [Table 12]

Control information	Physical Channel
DCI	PDCCH

[341] * Encoding

[342] Data and control streams from/to MAC layer are encoded to offer transport and control services over the radio transmission link in the PHY layer. For example, a transport block from MAC layer is encoded into a codeword at a transmitting side. Channel coding scheme is a combination of error detection, error correcting, rate matching, interleaving and transport channel or control information mapping onto/splitting from physical channels.

[343] In the 3GPP NR system, following channel coding schemes are used for the different types of TrCH and the different control information types.

[344]

[Table 13]

TrCH	Coding scheme
UL-SCH	LDPC
DL-SCH	
PCH	
BCH	Polar code

[345] [Table 14]

Control Information	Coding scheme
DCI	Polar code
UCI	Block code
	Polar code

[346] For transmission of a DL transport block (i.e. a DL MAC PDU) or a UL transport block (i.e. a UL MAC PDU), a transport block CRC sequence is attached to provide error detection for a receiving side. In the 3GPP NR system, the communication device uses low density parity check (LDPC) codes in encoding/decoding UL-SCH and DL-SCH. The 3GPP NR system supports two LDPC base graphs (i.e. two LDPC base matrixes): LDPC base graph 1 optimized for small transport blocks and LDPC base graph 2 for larger transport blocks. Either LDPC base graph 1 or 2 is selected based on the size of the transport block and coding rate R . The coding rate R is indicated by the modulation coding scheme (MCS) index I_{MCS} . The MCS index is dynamically provided to a UE by PDCCH scheduling PUSCH or PDSCH, provided to a UE by PDCCH activating or (re-)initializing the UL configured grant 2 or DL SPS, or provided to a UE by RRC signaling related to the UL configured grant Type 1. If the CRC attached transport block is larger than the maximum code block size for the selected LDPC base graph, the CRC attached transport block may be segmented into code blocks, and an additional CRC sequence is attached to each code block. The maximum code block sizes for the LDPC base graph 1 and the LDPC base graph 2 are 8448 bits and 3480 bits, respectively. If the CRC attached transport block is not larger than the maximum code block size for the selected LDPC base graph, the CRC attached transport block is encoded with the selected LDPC base graph. Each code block of the transport block is encoded with the selected LDPC base graph. The LDPC coded blocks are then individually rate matched. Code block concatenation is performed to create a codeword for transmission on PDSCH or PUSCH. For PDSCH, up to 2 codewords (i.e. up to 2 transport blocks) can be transmitted simultaneously on the PDSCH. PUSCH can be used for transmission of UL-SCH data and layer 1/2 control information. Although not shown in FIG. 24, the layer 1/2 control information may be multiplexed with the codeword for UL-SCH data.

[347] * Scrambling and modulation

- [348] The bits of the codeword are scrambled and modulated to generate a block of complex-valued modulation symbols.
- [349] * Layer mapping
- [350] The complex-valued modulation symbols of the codeword are mapped to one or more multiple input multiple output (MIMO) layers. A codeword can be mapped to up to 4 layers. A PDSCH can carry two codewords, and thus a PDSCH can support up to 8-layer transmission. A PUSCH supports a single codeword, and thus a PUSCH can support up to 4-layer transmission.
- [351] * Transform precoding
- [352] The DL transmission waveform is conventional OFDM using a cyclic prefix (CP). For DL, transform precoding (in other words, discrete Fourier transform (DFT)) is not applied.
- [353] The UL transmission waveform is conventional OFDM using a CP with a transform precoding function performing DFT spreading that can be disabled or enabled. In the 3GPP NR system, for UL, the transform precoding can be optionally applied if enabled. The transform precoding is to spread UL data in a special way to reduce peak-to-average power ratio (PAPR) of the waveform. The transform precoding is a form of DFT. In other words, the 3GPP NR system supports two options for UL waveform: one is CP-OFDM (same as DL waveform) and the other one is DFT-s-OFDM. Whether a UE has to use CP-OFDM or DFT-s-OFDM is configured by a BS via RRC parameters.
- [354] * Subcarrier mapping
- [355] The layers are mapped to antenna ports. In DL, for the layers to antenna ports mapping, a transparent manner (non-codebook based) mapping is supported and how beamforming or MIMO precoding is performed is transparent to the UE. In UL, for the layers to antenna ports mapping, both the non-codebook based mapping and a codebook based mapping are supported.
- [356] For each antenna port (i.e. layer) used for transmission of the physical channel (e.g. PDSCH, PUSCH), the complex-valued modulation symbols are mapped to subcarriers in resource blocks allocated to the physical channel.
- [357] * OFDM modulation
- [358] The communication device at the transmitting side generates a time-continuous OFDM baseband signal on antenna port p and subcarrier spacing configuration u for OFDM symbol l in a TTI for a physical channel by adding a cyclic prefix (CP) and performing IFFT. For example, for each OFDM symbol, the communication device at the transmitting side may perform inverse fast Fourier transform (IFFT) on the complex-valued modulation symbols mapped to resource blocks in the corresponding OFDM symbol and add a CP to the IFFT-ed signal to generate the OFDM baseband

signal.

[359] * Up-conversion

[360] The communication device at the transmitting side up-converts the OFDM baseband signal for antenna port p , subcarrier spacing configuration u and OFDM symbol l to a carrier frequency f_0 of a cell to which the physical channel is assigned.

[361] The processors 102 and 202 in FIG. 1B may be configured to perform encoding, scrambling, modulation, layer mapping, transform precoding (for UL), subcarrier mapping, and OFDM modulation. The processors 102 and 202 may control the transceivers 106 and 206 connected to the processors 102 and 202 to up-convert the OFDM baseband signal onto the carrier frequency to generate radio frequency (RF) signals. The radio frequency signals are transmitted through antennas 108 and 208 to an external device.

[362] FIG. 24(b) illustrates an example of physical layer processing at a receiving side.

[363] The physical layer processing at the receiving side is basically the inverse processing of the physical layer processing at the transmitting side.

[364] * Frequency down-conversion

[365] The communication device at a receiving side receives RF signals at a carrier frequency through antennas. The transceivers 106 and 206 receiving the RF signals at the carrier frequency down-converts the carrier frequency of the RF signals into the baseband in order to obtain OFDM baseband signals.

[366] * OFDM demodulation

[367] The communication device at the receiving side obtains complex-valued modulation symbols via CP detachment and FFT. For example, for each OFDM symbol, the communication device at the receiving side removes a CP from the OFDM baseband signals and performs FFT on the CP-removed OFDM baseband signals to obtain complex-valued modulation symbols for antenna port p , subcarrier spacing u and OFDM symbol l .

[368] * Subcarrier demapping

[369] The subcarrier demapping is performed on the complex-valued modulation symbols to obtain complex-valued modulation symbols of a corresponding physical channel. For example, the processor(s) 102 may obtain complex-valued modulation symbols mapped to subcarriers belong to PDSCH from among complex-valued modulation symbols received in a bandwidth part. For another example, the processor(s) 202 may obtain complex-valued modulation symbols mapped to subcarriers belong to PUSCH from among complex-valued modulation symbols received in a bandwidth part.

[370] * Transform de-precoding

[371] Transform de-precoding (e.g. IDFT) is performed on the complex-valued modulation symbols of the uplink physical channel if the transform precoding has been enabled for

the uplink physical channel. For the downlink physical channel and for the uplink physical channel for which the transform precoding has been disabled, the transform de-precoding is not performed.

[372] * Layer demapping.

[373] The complex-valued modulation symbols are de-mapped into one or two codewords.

[374] * Demodulation and descrambling

[375] The complex-valued modulation symbols of a codeword are demodulated and de-scrambled into bits of the codeword.

[376] * Decoding

[377] The codeword is decoded into a transport block. For UL-SCH and DL-SCH, either LDPC base graph 1 or 2 is selected based on the size of the transport block and coding rate R . The codeword may include one or multiple coded blocks. Each coded block is decoded with the selected LDPC base graph into a CRC-attached code block or CRC-attached transport block. If code block segmentation was performed on a CRC-attached transport block at the transmitting side, a CRC sequence is removed from each of CRC-attached code blocks, whereby code blocks are obtained. The code blocks are concatenated into a CRC-attached transport block. The transport block CRC sequence is removed from the CRC-attached transport block, whereby the transport block is obtained. The transport block is delivered to the MAC layer.

[378] In the above described physical layer processing at the transmitting and receiving sides, the time and frequency domain resources (e.g. OFDM symbol, subcarriers, carrier frequency) related to subcarrier mapping, OFDM modulation and frequency up/down conversion can be determined based on the resource allocation (e.g., UL grant, DL assignment).

[379] For uplink data transmission, the processor(s) 102 of the present disclosure may apply (or control the transceiver(s) 106 to apply) the above described physical layer processing of the transmitting side to UL data/signal (e.g. MAC PDU) of the present disclosure to transmit the UL data/signal wirelessly. For uplink data reception, the processor(s) 102 of the present disclosure may apply (or control the transceiver(s) 106 to apply) the above described physical layer processing of the receiving side to received radio signals to obtain the UL data/signal of the present disclosure.

[380] For downlink data transmission, the processor(s) 202 of the present disclosure may apply (or control the transceiver(s) 206 to apply) the above described physical layer processing of the transmitting side to DL data/signal (e.g. MAC PDU) of the present disclosure to transmit the DL data/signal wirelessly. For downlink data reception, the processor(s) 202 of the present disclosure may apply (or control the transceiver(s) 206 to apply) the above described physical layer processing of the receiving side to received radio signals to obtain DL data/signal of the present disclosure.

- [381] The processor(s) 102 may apply the above described physical layer processing of the transmitting side to the UL payload of the MsgA to transmit the UL payload of the MsgA message wirelessly. The processor(s) 202 may apply the above described physical layer processing of the receiving side to received radio signals to obtain the UL payload of the MsgA transmitted by the first device.
- [382] The processor(s) 202 may apply the above described physical layer processing of the transmitting side to an MsgB MAC PDU to transmit the MsgB MAC PDU wirelessly. The processor(s) 102 may apply the above described physical layer processing of the receiving side to received radio signals to obtain the MsgB MAC PDU transmitted by the second device.
- [383] In some implementations of the present disclosure, an RAP is transmitted in a preamble format. A preamble format for a RA procedure of the present disclosure may consist of a cyclic prefix (CP) and a sequence part in a time domain, or consist of a CP part, a sequence part and a guard period (GP) in the time domain. In a GP of a preamble format, no signal is transmitted by a UE. The processor(s) 102 of the first device 100 may be configured to perform the OFDM modulation and the up-conversion to the RAP. For example, the processor(s) 102 at the UE side generates a time-continuous OFDM baseband signal on antenna port p for PRACH by adding a cyclic prefix (CP) and performing IFFT. For example, the processor(s) 102 of the first device may perform inverse fast Fourier transform (IFFT) on a preamble part containing the RAP and add a CP to the IFFT-ed signal to generate the OFDM baseband signal for the PRACH. The processor(s) 102 controls the transceiver(s) 106 to up-convert the OFDM baseband signal for antenna port p for PRACH to a carrier frequency f_0 of a cell via which the RAP is transmitted.
- [384] The processor(s) 202 of the second device may be configured to control the transceiver(s) 206 to down-convert the RF signals received at a carrier frequency in a PRACH occasion (e.g. time-frequency resource for PRACH) in the baseband signal in order to obtain OFDM baseband signals for PRACH. The processor(s) 202 may obtain an RAP via CP detachment and FFT. For example, processor(s) 202 of the second device removes a CP from the OFDM baseband signals for PRACH and performs FFT on the CP-removed OFDM baseband signals to obtain the RAP for antenna port p for PRACH. If the processor(s) 202 obtains both an RAP in an MsgA of a first device 100 and a payload in the MsgA successfully, the processor(s) 202 may generate an MsgB MAC PDU containing a RAP ID for the RAP, and control the transceiver(s) 206 to transmit the MsgB MAC PDU during a RAR window for the first device 100.
- [385] According to the implementations of the present disclosure, a UE can quickly decode the MsgB when one or more MsgBs for different UEs are multiplexed into a MAC PDU, thereby reducing the UE processing delay of the MAC PDU decoding and

saving UE power consumption.

[386] As described above, the detailed description of the preferred implementations of the present disclosure has been given to enable those skilled in the art to implement and practice the disclosure. Although the disclosure has been described with reference to exemplary implementations, those skilled in the art will appreciate that various modifications and variations can be made in the present disclosure without departing from the spirit or scope of the disclosure described in the appended claims. Accordingly, the disclosure should not be limited to the specific implementations described herein, but should be accorded the broadest scope consistent with the principles and novel features disclosed herein.

Industrial Applicability

[387] The implementations of the present disclosure are applicable to a network node (e.g., BS), a UE, or other devices in a wireless communication system.

Claims

- [Claim 1] A method for performing a random access (RA) procedure by a user equipment (UE) in a wireless communication system, the method comprising:
transmitting a random access preamble (RAP) on a physical random access channel (PRACH) and a control channel (CCCH) service data unit (SDU) on a physical uplink shared channel (PUSCH); and
receiving a medium access control (MAC) protocol data unit (PDU) based on transmitting the RAP and the CCCH SDU,
wherein the MAC PDU includes a first part, and a second part after the first part, and
wherein the first part includes multiple UE contention resolution identities (UE CRIDs).
- [Claim 2] The method according to claim 1,
wherein the second part includes respective timing advance commands for the multiple UE CRIDs.
- [Claim 3] The method according to claim 1, further comprising:
determining whether the multiple UE CRIDs include a UE CRID matching the CCCH SDU, and
processing a timing advance command corresponding to the UE CRID based on determining that the multiple UE CRIDs include the UE CRID matching the CCCH SDU.
- [Claim 4] The method according to the claim 1,
wherein the MAC PDU includes a UE CRID MAC control element (CE), and
wherein the multiple UE CRIDs are included in the UE CRID MAC CE.
- [Claim 5] The method according to claim 4,
wherein the MAC PDU further includes a MAC subheader for the UE CRID MAC CE, and
wherein the MAC subheader includes a logical channel identity (LCID) field set to a value representing the UE CRID MAC CE that includes the multiple UE CRIDs.
- [Claim 6] The method according to claim 5,
wherein the MAC subheader includes a length field set to a value indicating the size of the UE CRID MAC CE.
- [Claim 7] A user equipment (UE) of performing a random access (RA) procedure

in a wireless communication system, the UE comprising:
at least one transceiver;
at least one processor; and
at least one computer memory storing instructions which, when executed, cause the at least one processor to perform operations comprising:
transmitting a random access preamble (RAP) on a physical random access channel (PRACH) and a control channel (CCCH) service data unit (SDU) on a physical uplink shared channel (PUSCH); and
receiving a medium access control (MAC) protocol data unit (PDU) based on transmitting the RAP and the CCCH SDU,
wherein the MAC PDU includes a first part, and a second part after the first part, and
wherein the first part includes multiple UE contention resolution identities (UE CRIDs).

[Claim 8] The UE according to claim 7,
wherein the second part includes respective timing advance commands for the multiple UE CRIDs.

[Claim 9] The UE according to claim 7, wherein the operations further comprise:
determining whether the multiple UE CRIDs include a UE CRID matching the CCCH SDU, and
processing a timing advance command corresponding to the UE CRID based on determining that the multiple UE CRIDs include the UE CRID matching the CCCH SDU.

[Claim 10] The UE according to the claim 7,
wherein the MAC PDU includes a UE CRID MAC control element (CE), and
wherein the multiple UE CRIDs are included in the UE CRID MAC CE.

[Claim 11] The UE according to claim 10,
wherein the MAC PDU further includes a MAC subheader for the UE CRID MAC CE, and
wherein the MAC subheader includes a logical channel identity (LCID) field set to a value representing the UE CRID MAC CE that includes the multiple UE CRIDs.

[Claim 12] The UE according to claim 11,
wherein the MAC subheader includes a length field set to a value indicating the size of the UE CRID MAC CE.

- [Claim 13] An apparatus for a transmitting device, the apparatus comprising:
at least one processor; and
at least one computer memory storing instructions which, when executed, cause the at least one processor to perform operations comprising:
transmitting a random access preamble (RAP) on a physical random access channel (PRACH) and a control channel (CCCH) service data unit (SDU) on a physical uplink shared channel (PUSCH); and
receiving a medium access control (MAC) protocol data unit (PDU) based on transmitting the RAP and the CCCH SDU,
wherein the MAC PDU includes a first part, and a second part after the first part, and
wherein the first part includes multiple UE contention resolution identities (UE CRIDs).
- [Claim 14] A computer readable storage medium storing at least one program that include instructions which, when executed, cause the at least one processor to perform operations comprising:
transmitting a random access preamble (RAP) on a physical random access channel (PRACH) and a control channel (CCCH) service data unit (SDU) on a physical uplink shared channel (PUSCH); and
receiving a medium access control (MAC) protocol data unit (PDU) based on transmitting the RAP and the CCCH SDU,
wherein the MAC PDU includes a first part, and a second part after the first part, and
wherein the first part includes multiple UE contention resolution identities (UE CRIDs).

[Fig. 1]

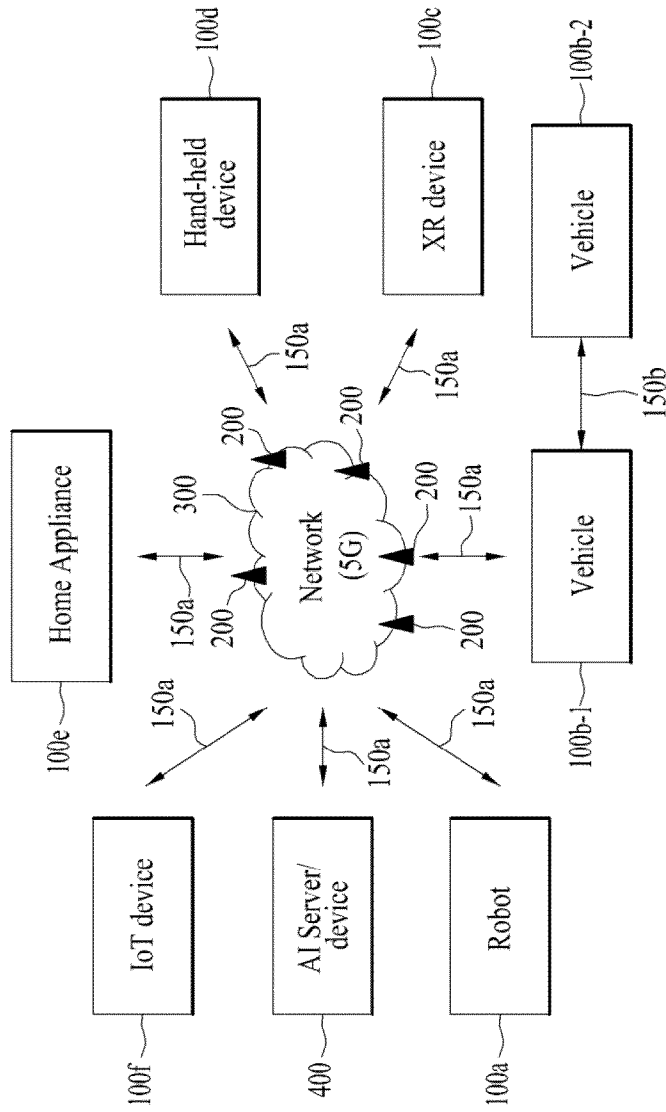

[Fig. 2]

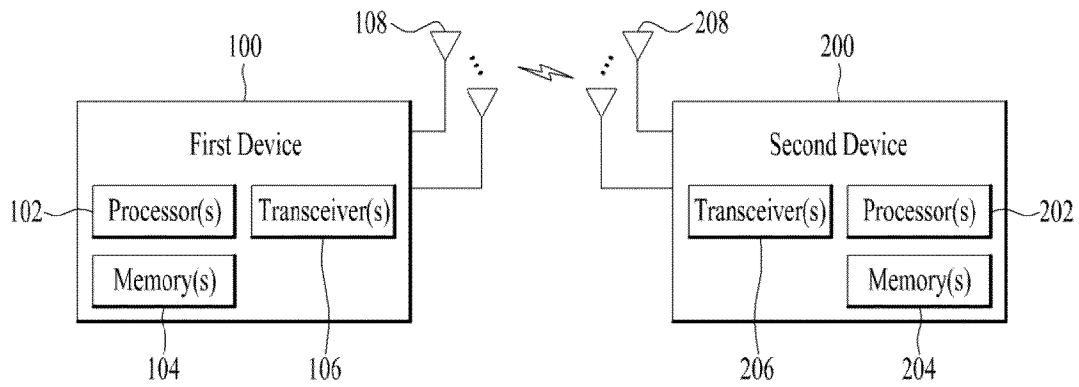

[Fig. 3]

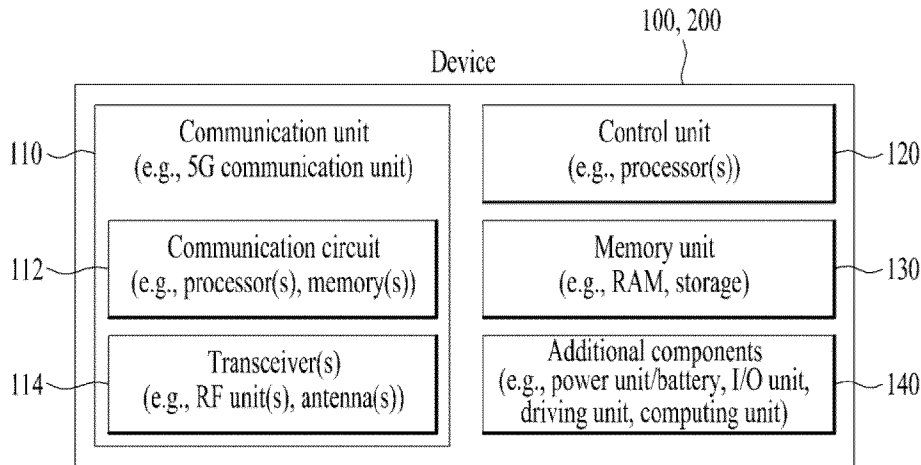

[Fig. 4]

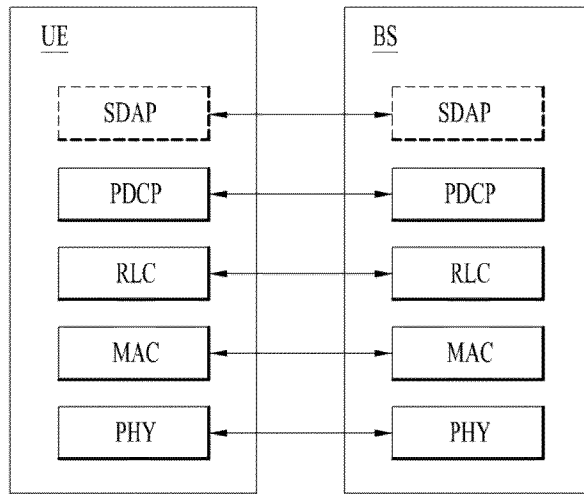

(a) User Plane Protocol Stack

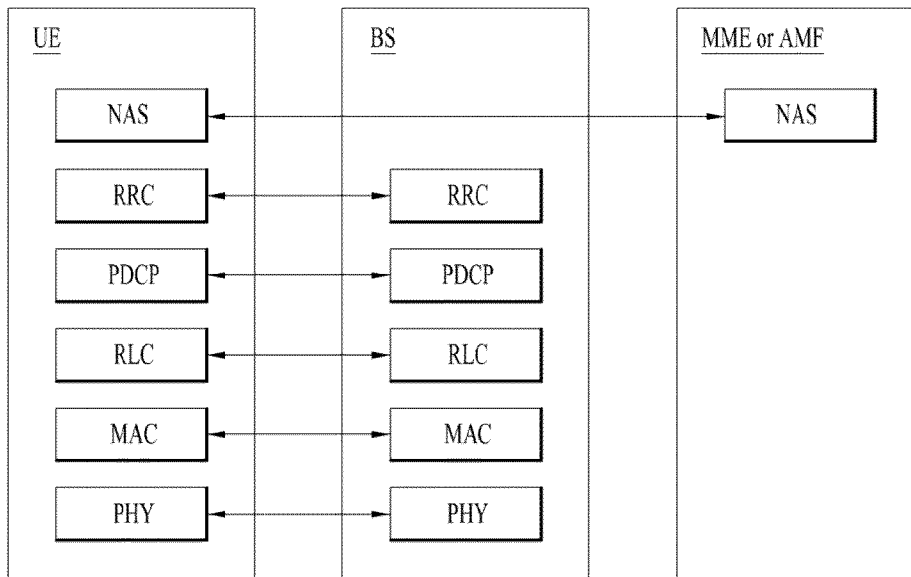

(b) Control Plane Protocol Stack

[Fig. 5]

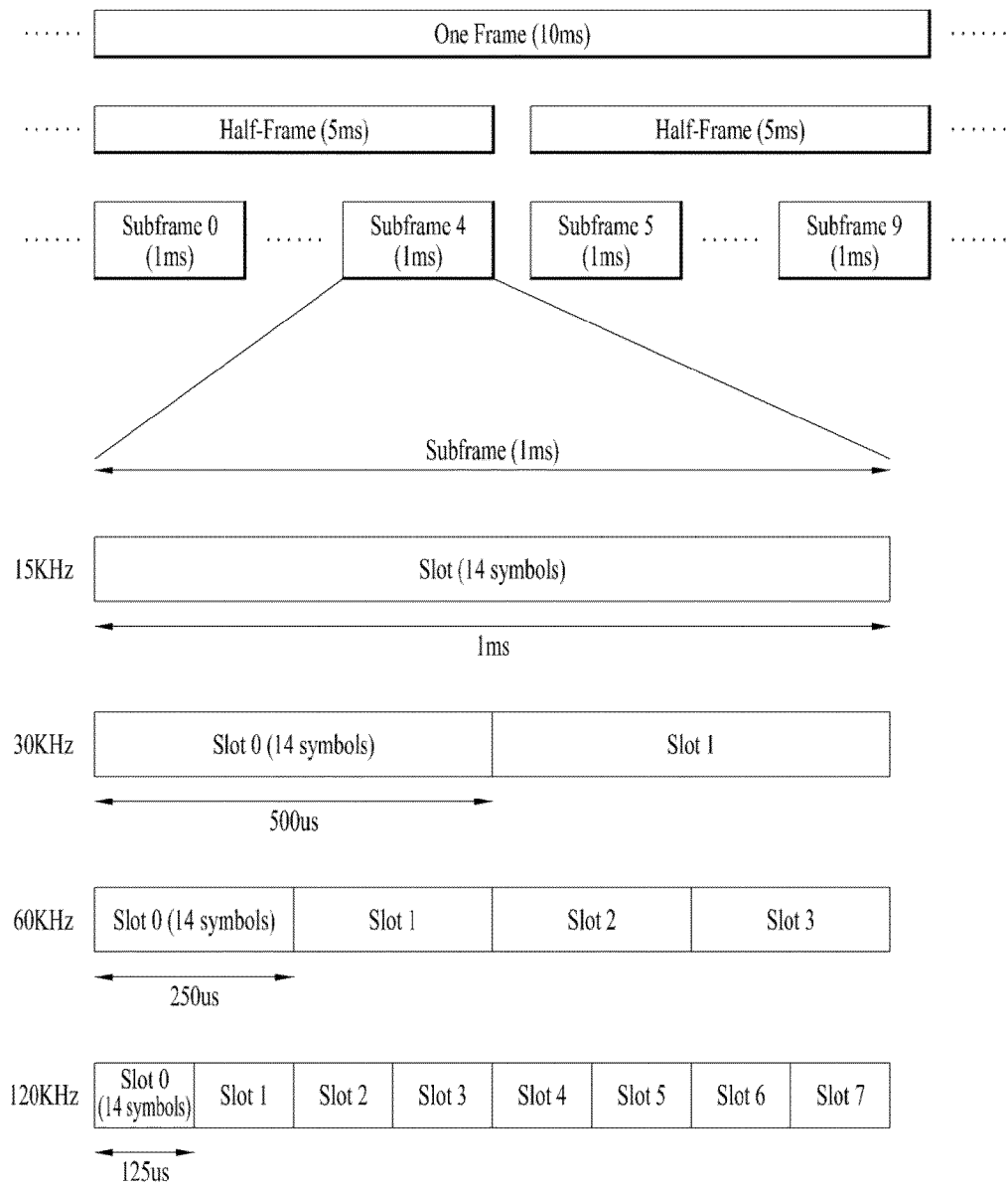

[Fig. 6]

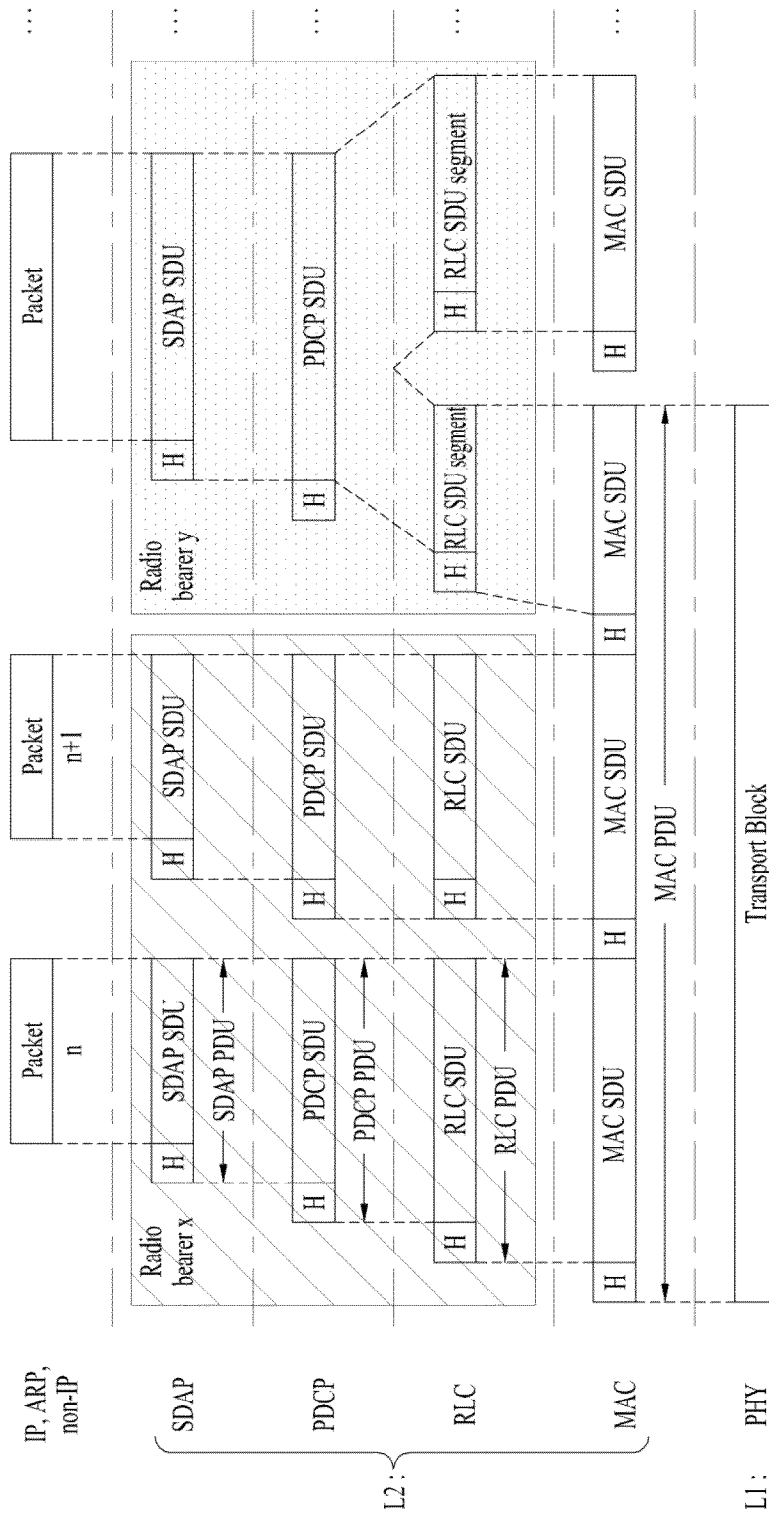

[Fig. 7]

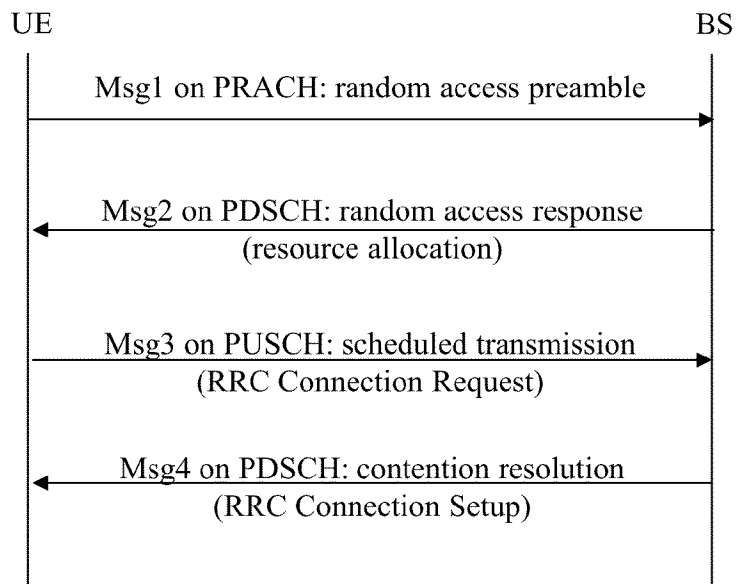

[Fig. 8]

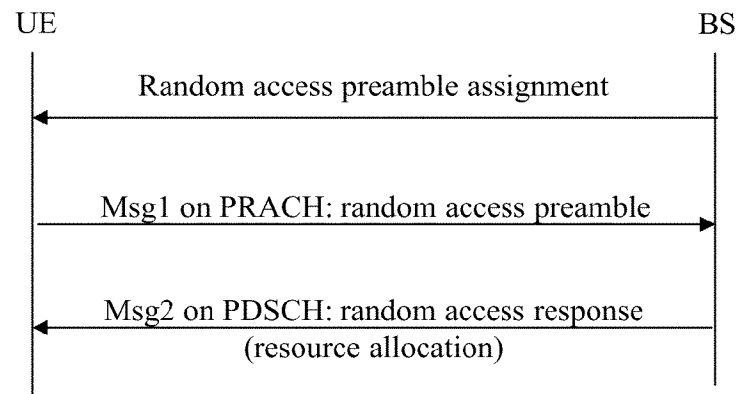

[Fig. 9]

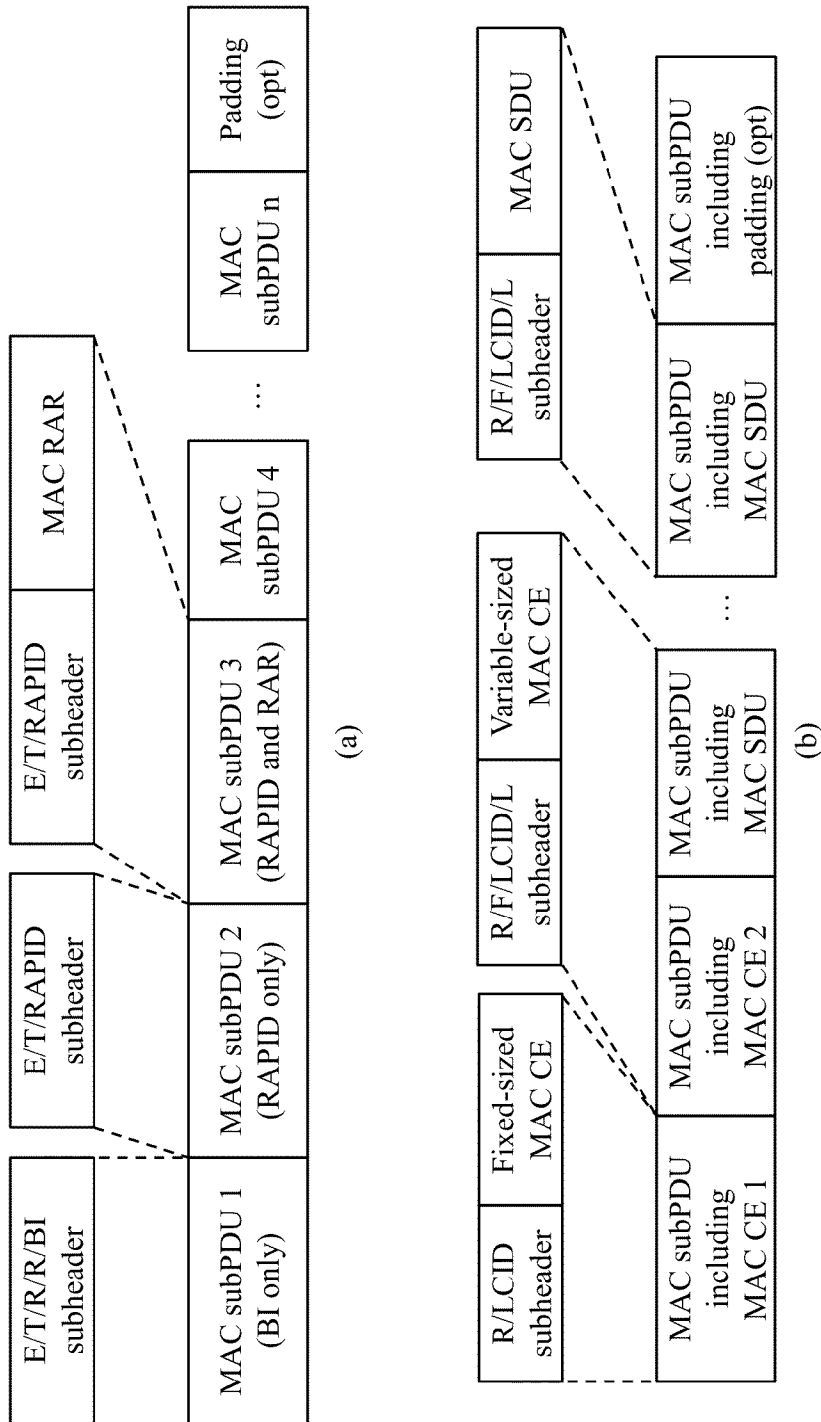

[Fig. 10]

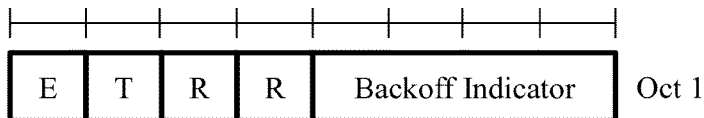

(a) E/T/R/R/BI MAC subheader

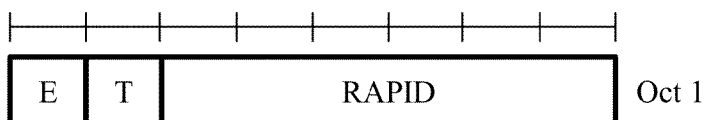

(b) E/T/RAPID MAC subheader

[Fig. 11]

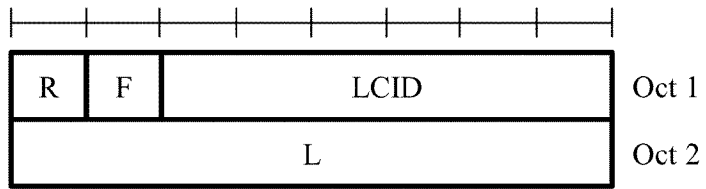

(a) R/F/LCID/L MAC subheader with 8-bit L field

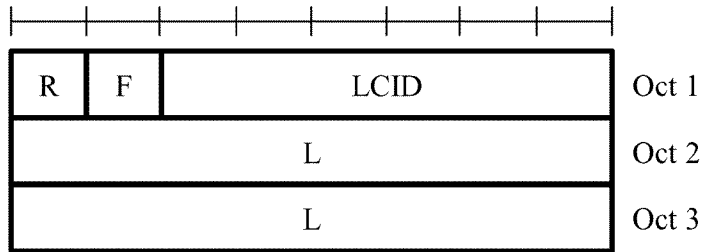

(b) R/F/LCID/L MAC subheader with 16-bit L field

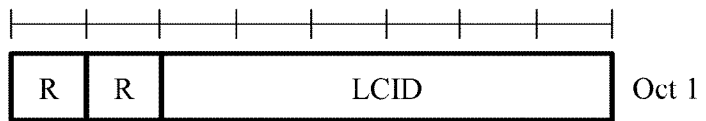

(c) R/LCID MAC subheader

[Fig. 12]

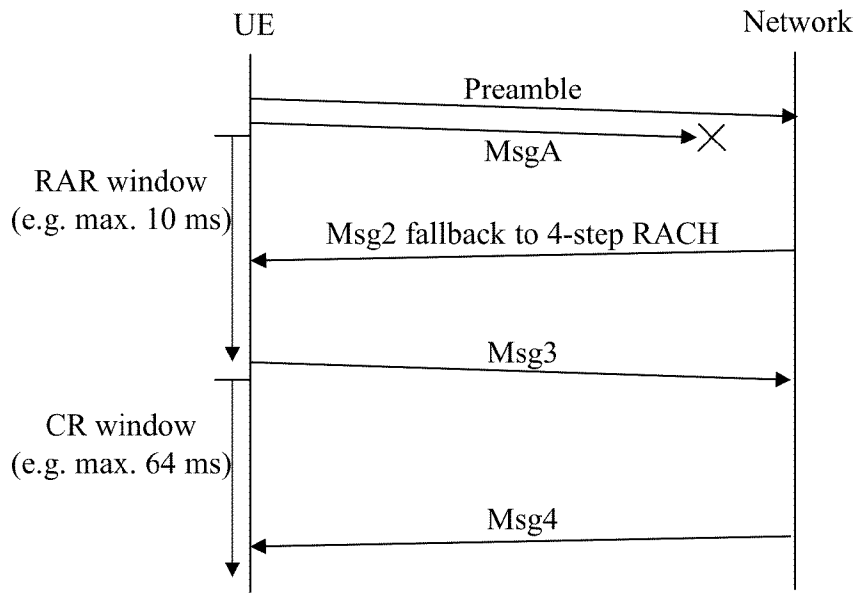

(a)

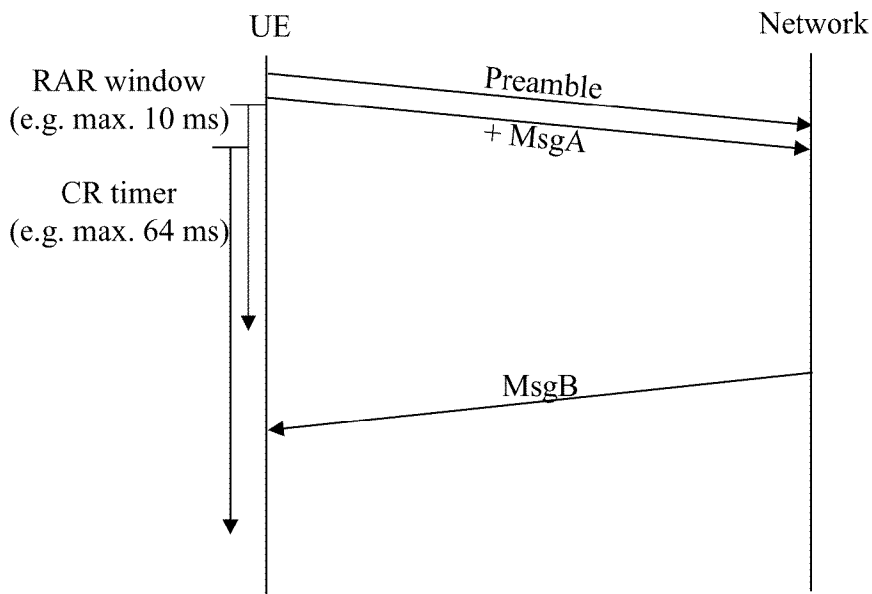

(b)

[Fig. 13]

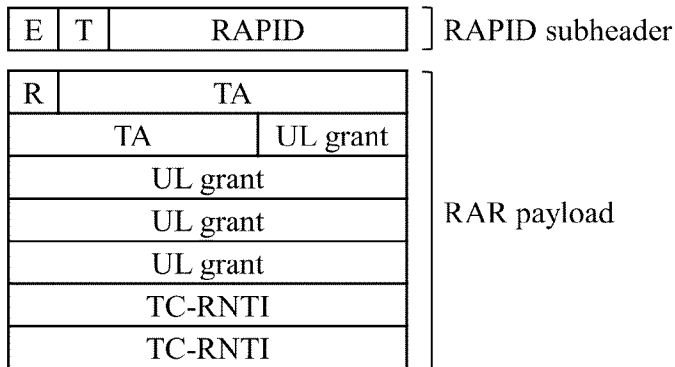

[Fig. 14]

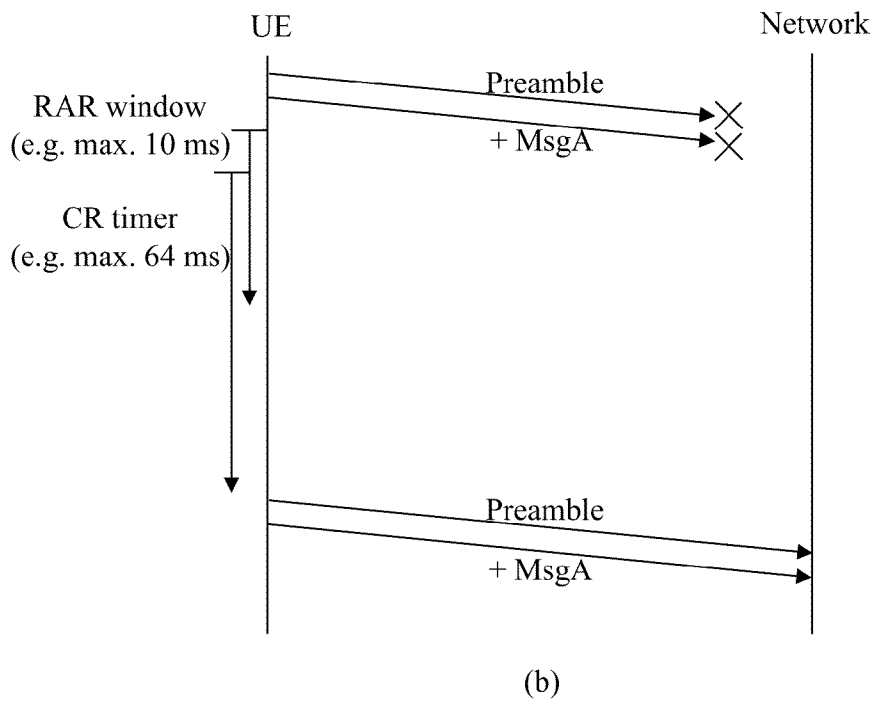
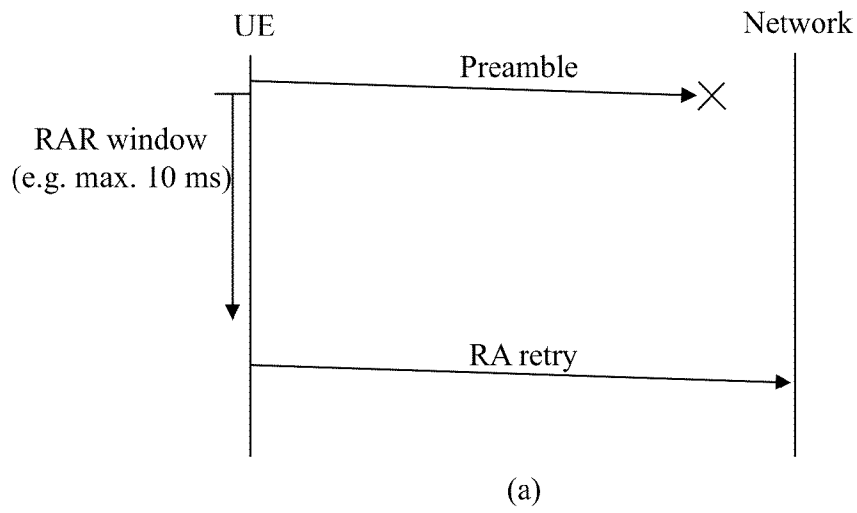

[Fig. 15]

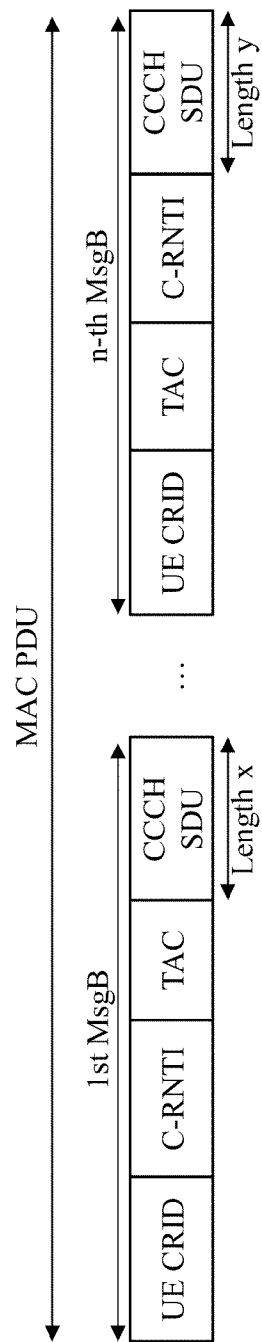

[Fig. 16]

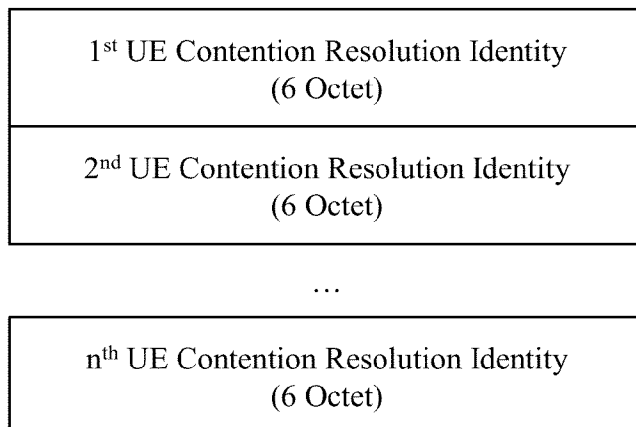

[Fig. 17]

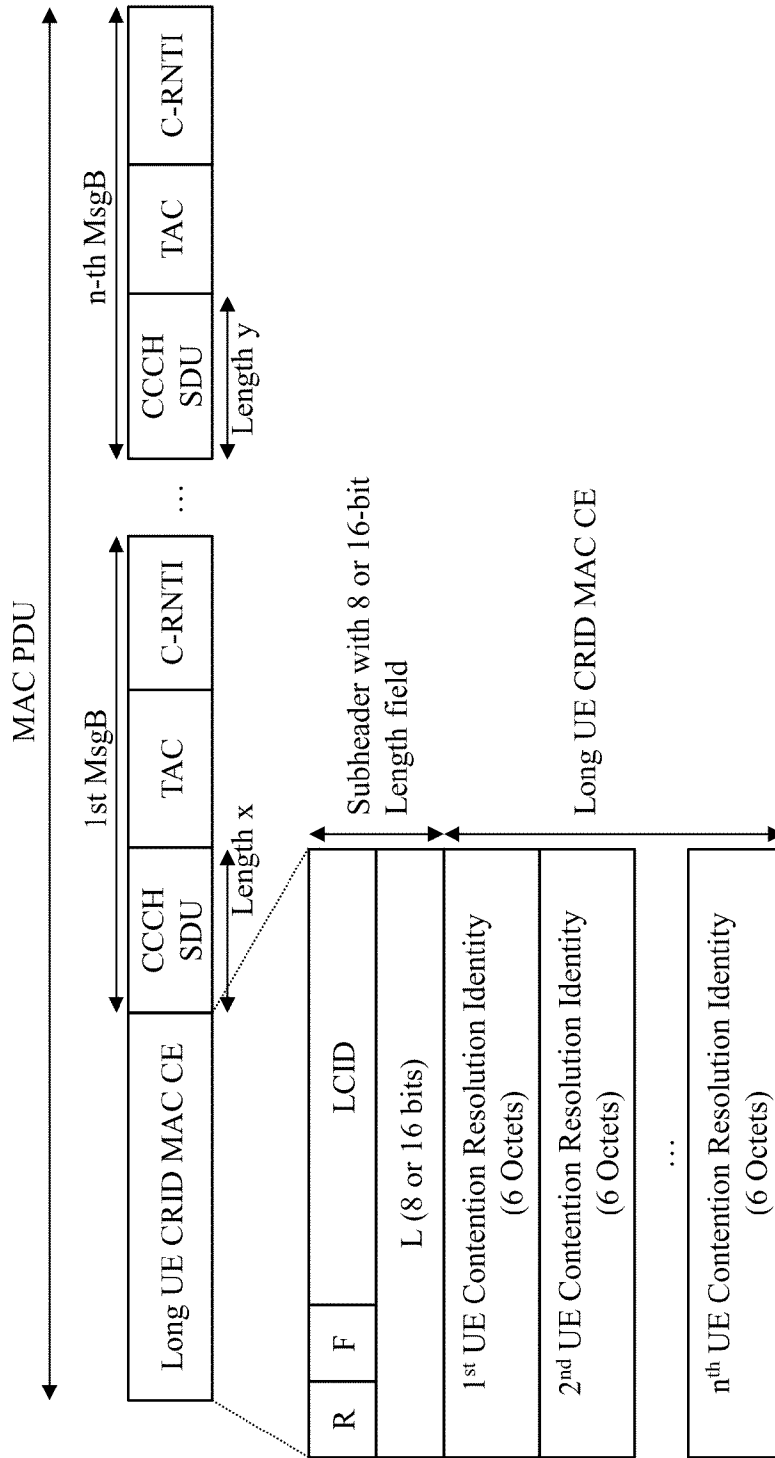

[Fig. 18]

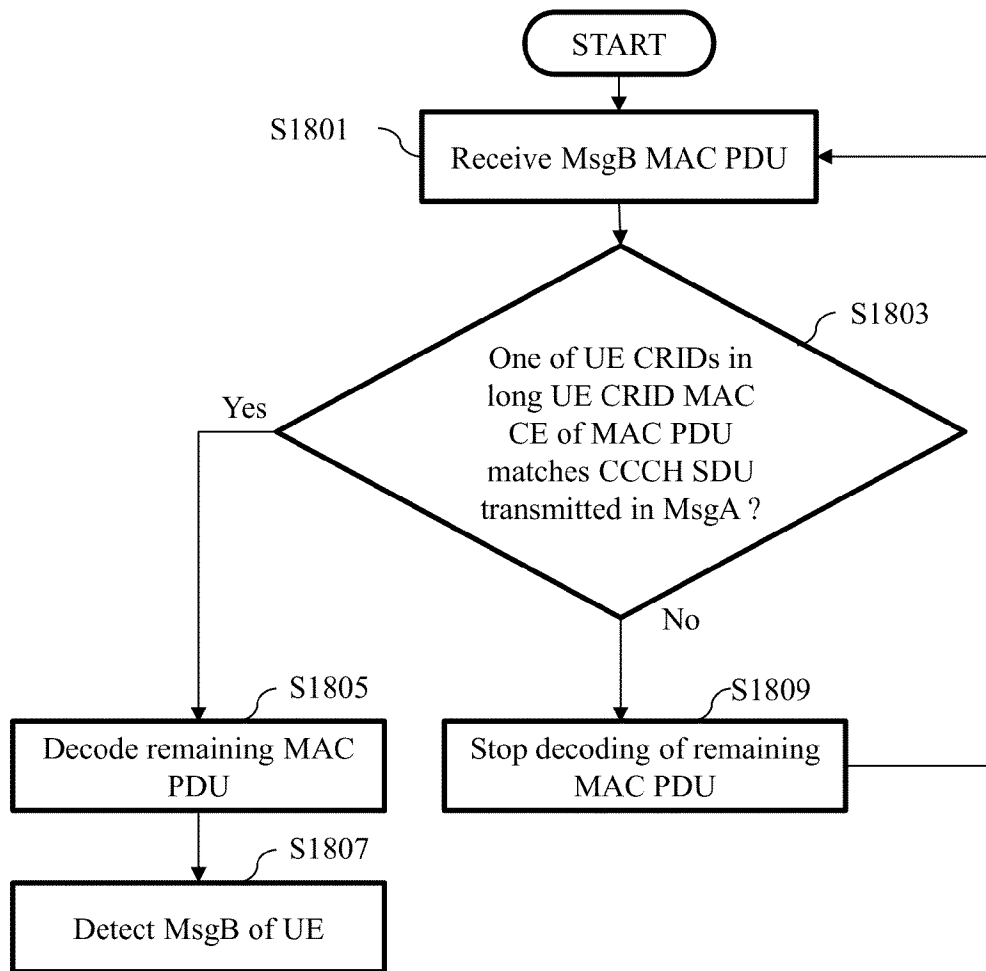

[Fig. 19]

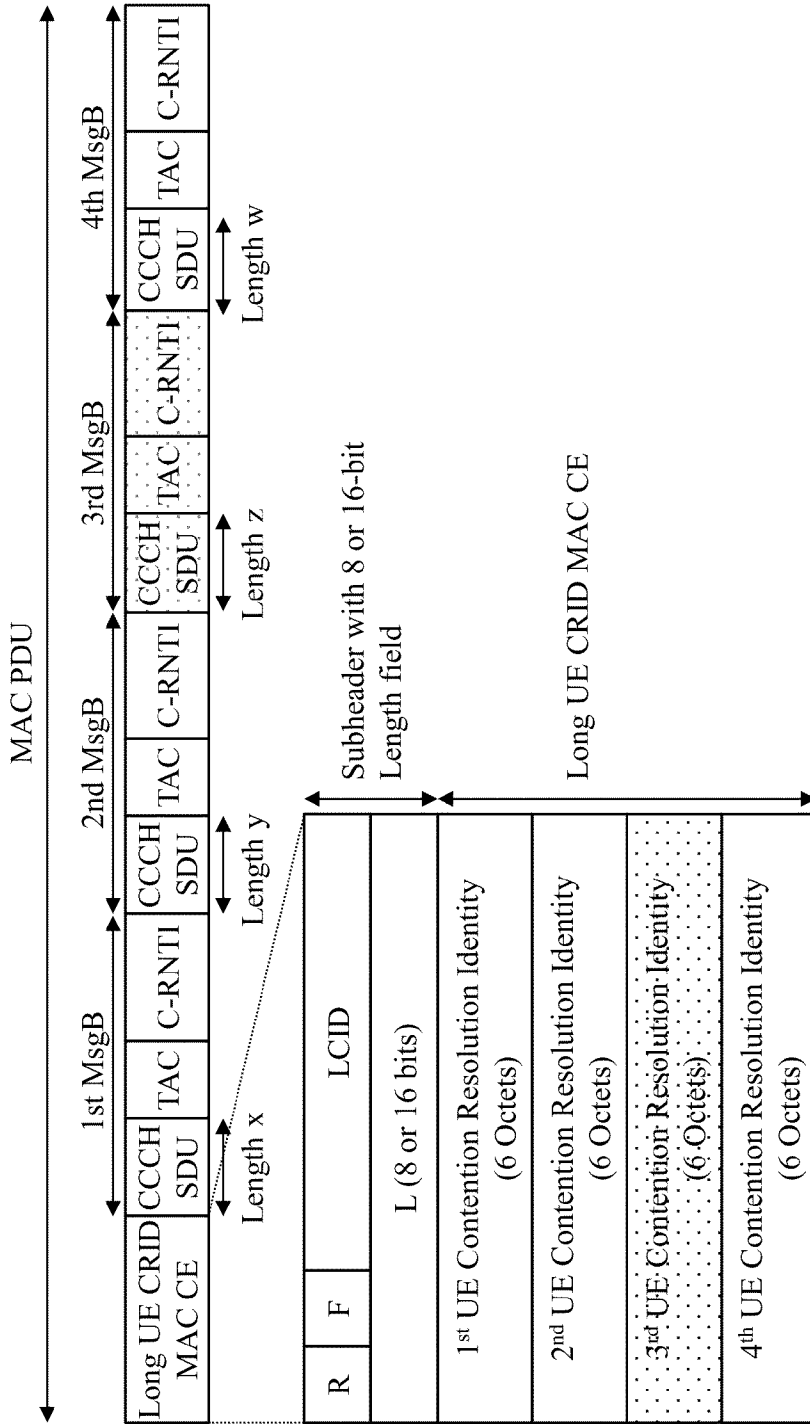

[Fig. 20]

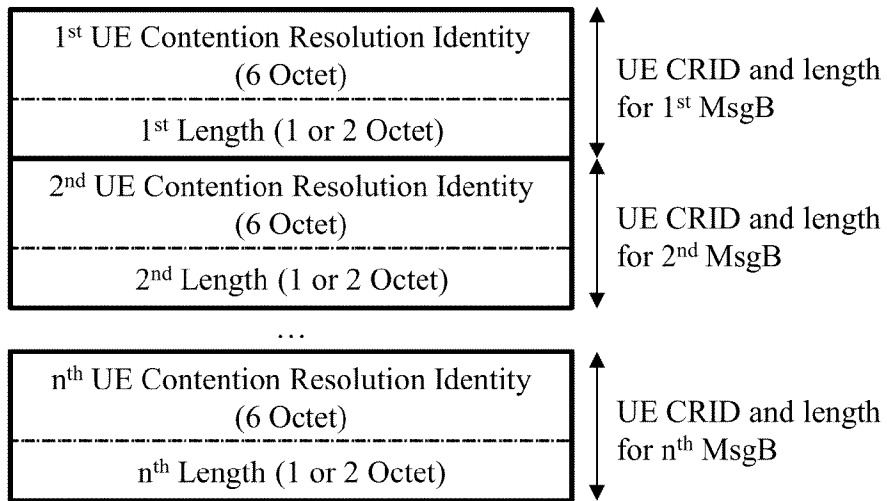

[Fig. 21]

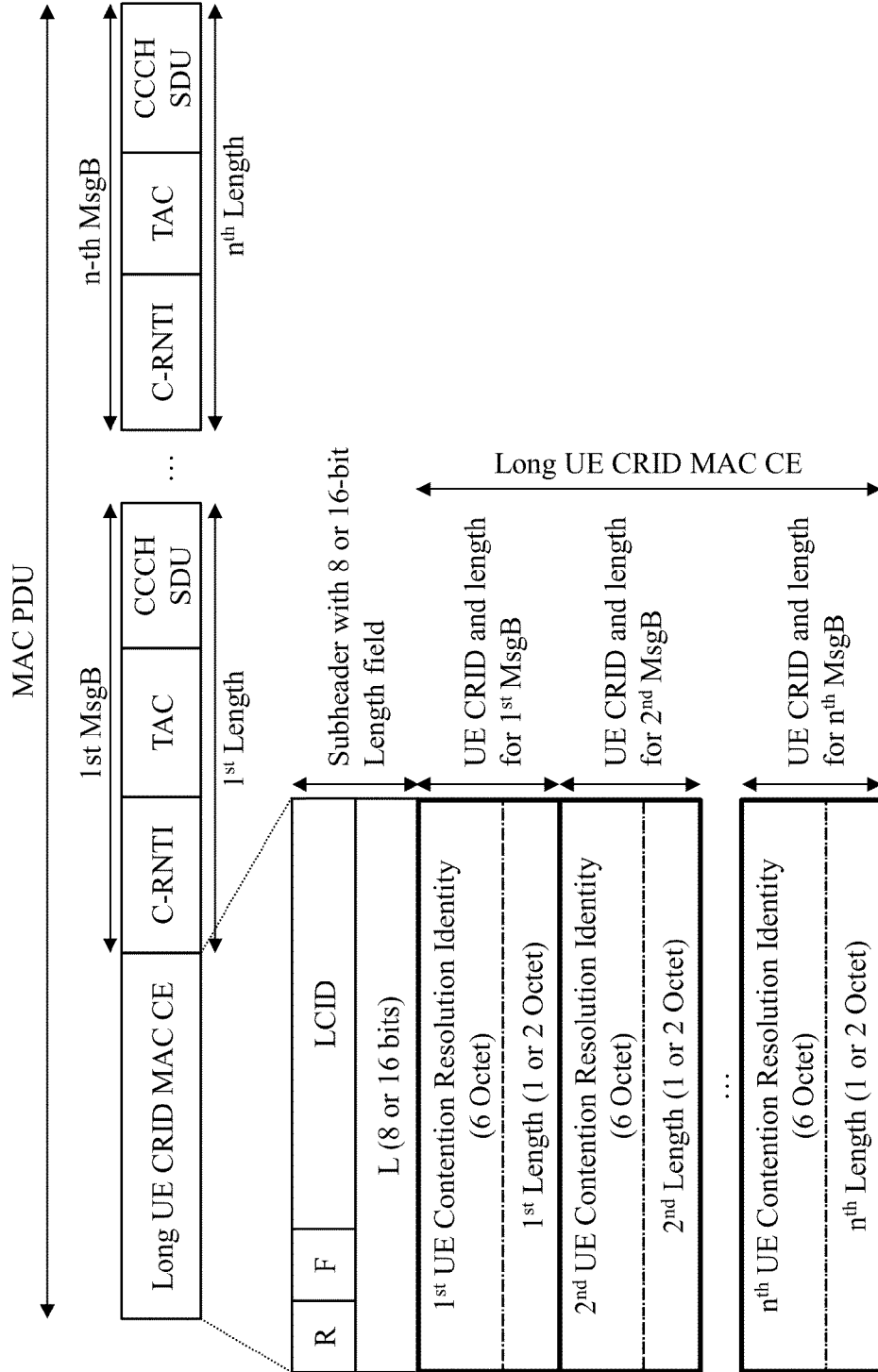

[Fig. 22]

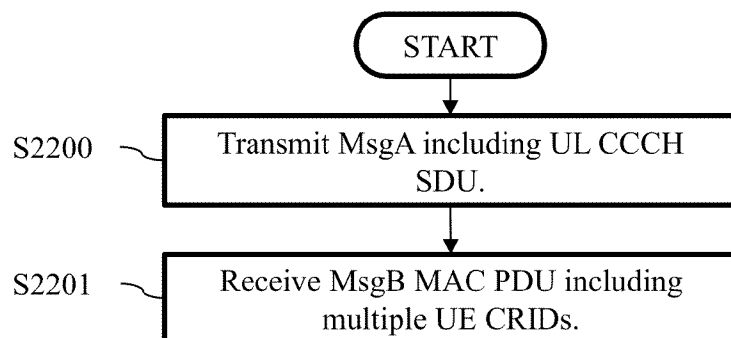

[Fig. 23]

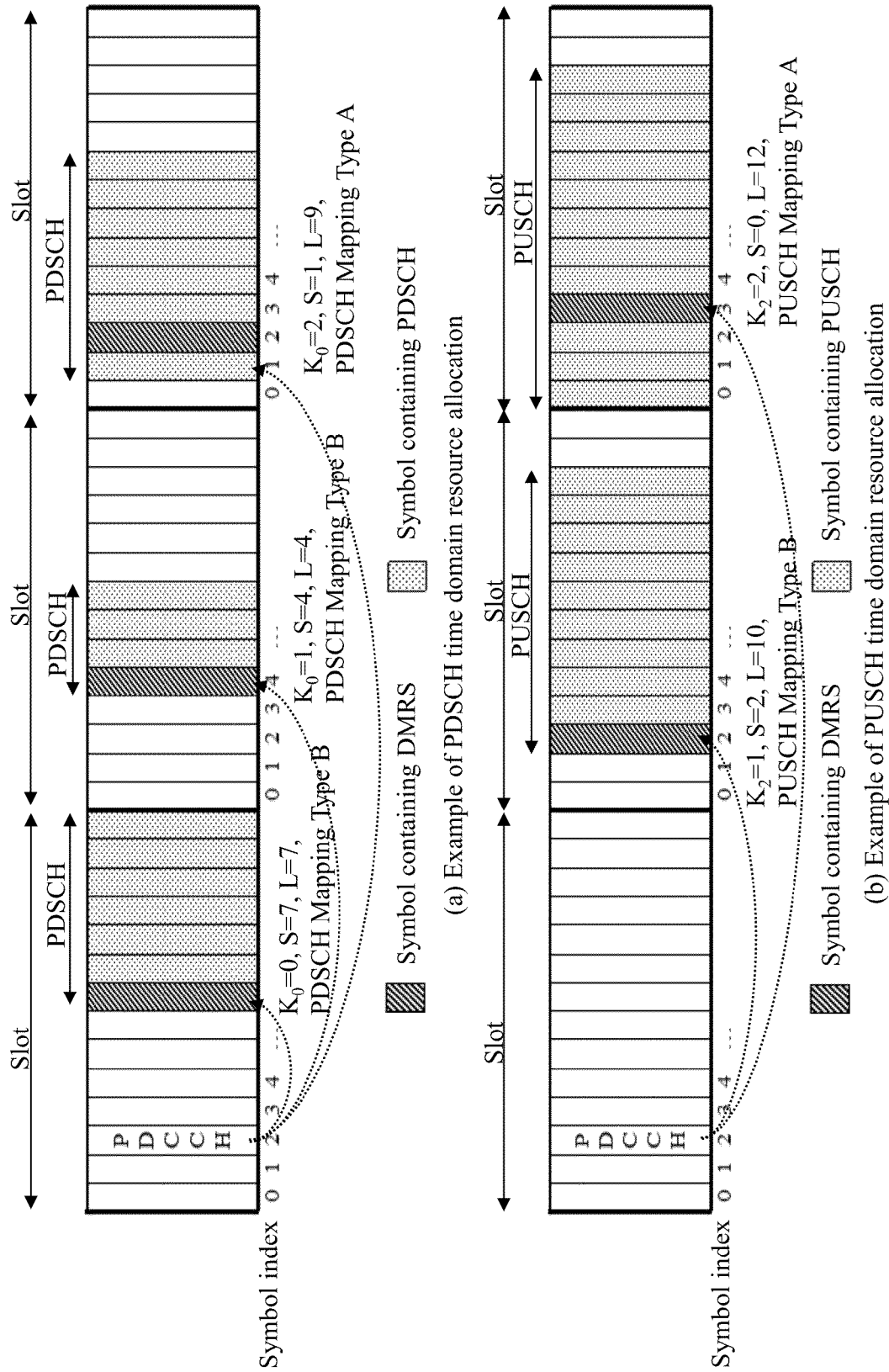

[Fig. 24]

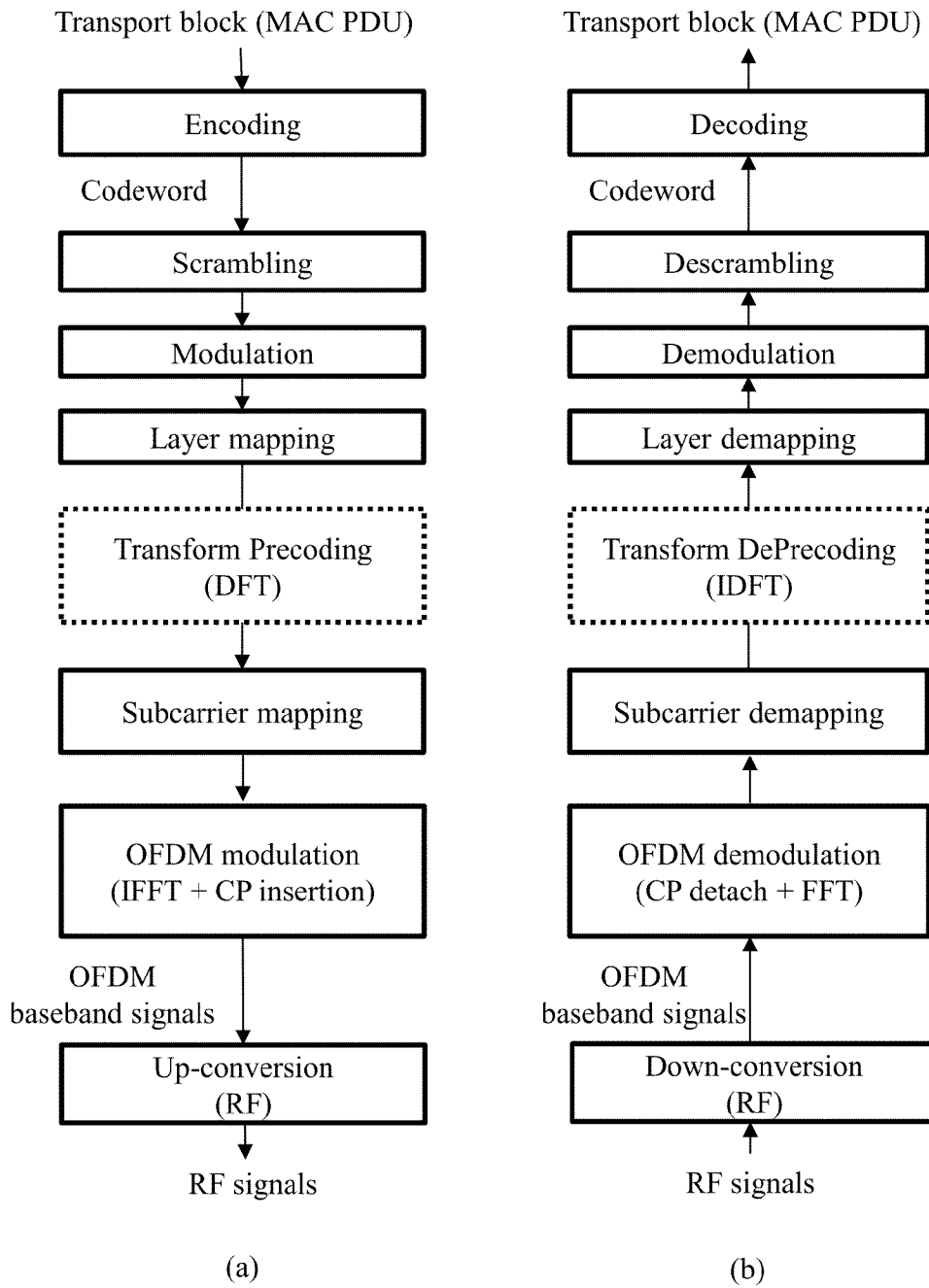

INTERNATIONAL SEARCH REPORT

International application No.
PCT/KR2020/004900**A. CLASSIFICATION OF SUBJECT MATTER****H04W 74/00(2009.01)i, H04W 74/08(2009.01)i, H04W 72/12(2009.01)i**

According to International Patent Classification (IPC) or to both national classification and IPC

B. FIELDS SEARCHEDMinimum documentation searched (classification system followed by classification symbols)
H04W 74/00; H04W 76/27; H04W 76/28; H04W 74/08; H04W 72/12Documentation searched other than minimum documentation to the extent that such documents are included in the fields searched
Korean utility models and applications for utility models
Japanese utility models and applications for utility modelsElectronic data base consulted during the international search (name of data base and, where practicable, search terms used)
eKOMPASS(KIPO internal) & keywords: RAP (random access preamble), PRACH, CCCH SDU, PUSCH, MAC PDU, first part, second part, UE CRID, match, timing advance, LCID**C. DOCUMENTS CONSIDERED TO BE RELEVANT**

Category*	Citation of document, with indication, where appropriate, of the relevant passages	Relevant to claim No.
X	LG ELECTRONICS INC., 'Contents in MAC layer of msgA and msgB' , R2-1903731, 3GPP TSG-RAN WG2 Meeting #105bis, 29 March 2019 section 2	1-4, 7-10, 13-14
Y		5, 11
A		6, 12
Y	INTEL CORPORATION, 'Contention resolution for different RACH msg 3 sizes' , R2-1807344, 3GPP TSG-RAN WG2 Meeting #102, 11 May 2018 section 5	5, 11
A	LG ELECTRONICS INC., 'Contention-based 2-Step RACH procedure' , R2-1903729, 3GPP TSG-RAN WG2 Meeting #105bis, 29 March 2019 section 2	1-14
A	NOKIA et al., 'On 2-step RACH Procedure' , R1-1904716, 3GPP TSG RAN WG1 #96bis, 29 March 2019 section 2	1-14
A	US 2018-0206290 A1 (ZTE CORPORATION) 19 July 2018 paragraphs [0245]-[0338]; and figure 1	1-14

 Further documents are listed in the continuation of Box C. See patent family annex.

* Special categories of cited documents:

"A" document defining the general state of the art which is not considered to be of particular relevance

"D" document cited by the applicant in the international application

"E" earlier application or patent but published on or after the international filing date

"L" document which may throw doubts on priority claim(s) or which is cited to establish the publication date of another citation or other special reason (as specified)

"O" document referring to an oral disclosure, use, exhibition or other means

"P" document published prior to the international filing date but later than the priority date claimed

"T" later document published after the international filing date or priority date and not in conflict with the application but cited to understand the principle or theory underlying the invention

"X" document of particular relevance; the claimed invention cannot be considered novel or cannot be considered to involve an inventive step when the document is taken alone

"Y" document of particular relevance; the claimed invention cannot be considered to involve an inventive step when the document is combined with one or more other such documents, such combination being obvious to a person skilled in the art

"&" document member of the same patent family

Date of the actual completion of the international search

21 July 2020 (21.07.2020)

Date of mailing of the international search report

22 July 2020 (22.07.2020)

Name and mailing address of the ISA/KR

International Application Division

Korean Intellectual Property Office

189 Cheongsa-ro, Seo-gu, Daejeon, 35208, Republic of Korea

Facsimile No. +82-42-481-8578

Authorized officer

YANG JEONG ROK

Telephone No. +82-42-481-5709



INTERNATIONAL SEARCH REPORT

Information on patent family members

International application No.

PCT/KR2020/004900

Patent document cited in search report	Publication date	Patent family member(s)	Publication date
US 2018-0206290 A1	19/07/2018	CN 107046728 A	15/08/2017
		EP 3393193 A1	24/10/2018
		JP 2019-505133 A	21/02/2019
		JP 6685412 B2	22/04/2020
		KR 10-2018-0109986 A	08/10/2018
		US 10440774 B2	08/10/2019
		US 2019-0373669 A1	05/12/2019
		WO 2017-133565 A1	10/08/2017